



(11)

EP 2 706 164 A1

(12) **EUROPEAN PATENT APPLICATION**

(43) Date of publication:
12.03.2014 Bulletin 2014/11

(51) Int Cl.:
E04C 2/52 (2006.01)

(21) Application number: **12183746.2**

(22) Date of filing: **10.09.2012**

(84) Designated Contracting States:
AL AT BE BG CH CY CZ DE DK EE ES FI FR GB GR HR HU IE IS IT LI LT LU LV MC MK MT NL NO PL PT RO RS SE SI SK SM TR
Designated Extension States:
BA ME

• **Gemici, Zafer**
34220 Istanbul (TR)

(74) Representative: **Sevinç, Erkan**
Istanbul Patent & Trademark
Consultancy Ltd.
Plaza 33, Buyukdere Cad. No: 33/16
Sisli
34381 Istanbul (TR)

(71) Applicant: **Mir Arastirma ve Gelistirme A.S.**
34220 Istanbul (TR)

(72) Inventors:
• **Koca, Alihsan**
34220 Istanbul (TR)

(54) **Modular hybrid wall assembly**

(57) This invention relates to a hybrid wall assembly module (23) for use in construction of buildings and a modular hybrid wall assembly having said modules offering complete construction unit with a heat exchanger system in conjunction with insulation and supporting con-

structional elements, wherein the modular hybrid wall assembly module comprises a fore plate as well as fluid pipes and constructional elements. The module and assembly provide a robust and practical construction unit which is mountable in a snap fitting manner.

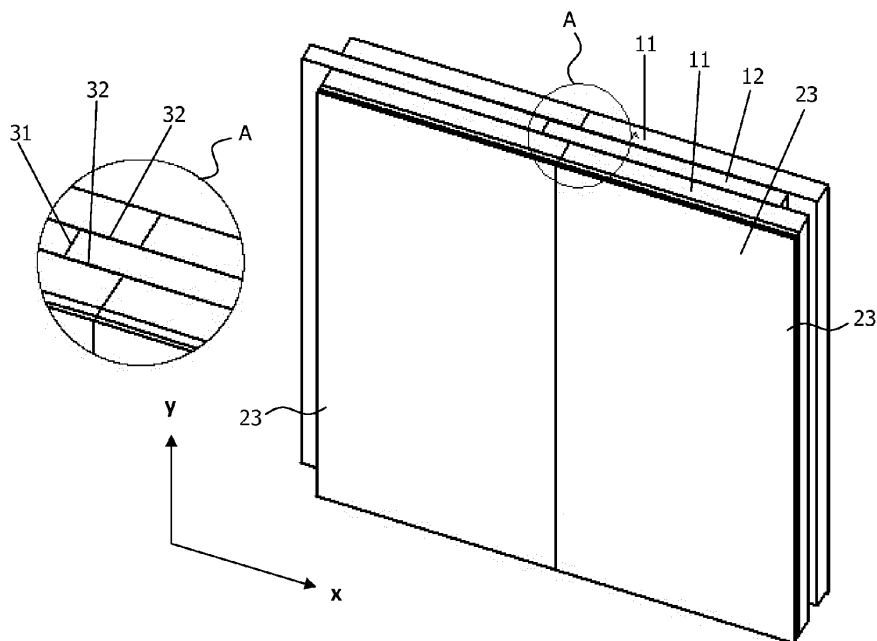

(a)

Figure 8

EP 2 706 164 A1

Description

Technical Field of the Invention

[0001] The present invention relates to a modular hybrid wall assembly module supplied with temperature adjustment installations. Optimal adjustment of radiant heating and/or cooling panels with supporting constructional elements, design of which is adjustable for heat load values according to different geographical and environmental conditions, is proposed for both interior and exterior walls of residential and commercial buildings.

Background of the Invention

[0002] Effective adjustment of ambient temperature in interior spaces of the buildings is an important issue for solution of which many methods are proposed since years.

[0003] Use of hot water radiators is a method which has solved the problem of utilizing dangerous surfaces with very high fuel incineration temperatures e.g. stoves. But the contact with the radiator surfaces is still dangerous for individuals, since the radiator surface temperatures are still high for a comfortable contact. Touching the radiator surface unintentionally may lead to accidents followed by possible injuries and damages because of unexpected and sudden discomfort.

[0004] Additionally, the problem of heating the air using only limited hot surfaces of the conventional radiator, and limiting the heat transfer only with an amount of radiation and mainly utilizing natural convection keeps the conventional radiator being still a weak solution for the ideal temperature adjustment. Thus, the temperature profile throughout the room was still highly variable and still uncomfortable, unhealthy and unpredictable.

[0005] Utilizing air conditioners and heaters/coolers with blowers may be considered as an alternative solution for diminishing the differences across the temperature profile throughout the room, which is convenient especially for the articles. However, these devices generate a continuous and often unhealthy airflow arising from forced convection, which disturbs people exposed to it.

[0006] Embedding pipes into the floor, ceiling and walls is another approach to support the heating and/or cooling of the rooms with larger heat transfer surfaces. This also helps in utilizing fluids with temperature values closer to the ambient temperatures, hence, the injury and accident risks were reduced. Earlier, the technique has been applied using rigid flow paths including concrete or metal pipelines embedded into walls and covering them with alum or plaster during construction of the building wall. This approach bears the problem of high reparation costs of leakages, which can be fixed only with an expensive destruction.

[0007] Later, the industry came up with more practical solutions like modular panels with pre-mounted pipelines (AT405429-A and EP 2397322-A2), or mounting and

plastering of heating mats or pipes on existing walls (All-Form™ by USH Innovationen GmbH, Germany). This approach helps with installation of heating/cooling systems on an existing wall, but still does not support the acquisition of flexible and convenient radiant panel montage along with the construction of supporting constructional elements at the same time.

[0008] In a constructional manner, it is not very possible to think the broadly used heating/cooling panels apart of the wall concept itself. The heat losses and gains through the wall structure are calculated and used while developing civil projects. Therefore the existence and properties of a heating/cooling panel is highly dependent with the properties of the wall itself.

[0009] The vital parameters such as insulation type, insulation thickness and distance between pipes, should be considered whilst calculating the heat transfer rates and investment costs, yet the panels in the market are provided in only a few standard types instead of being engineered according to the important variables e.g. several constructional details and climate conditions.

[0010] This leads to improper adjustment and lack of optimization of energy, cost and comfort between the panels and existing constructional properties of the building. Furthermore, separate and irrelevant applications, projects and labor following each other increase the costs and time losses dramatically.

[0011] The external thermal insulation of the buildings in a post constructional phase requires extensive labor and the applied insulation tends to show a low performance compared to project predictions. This is because of the highly possible imperfections and defects caused by difficult workmanship. Additionally, these defects shorten the efficient lifespan of the insulation dramatically.

[0012] Even though some examples of hybrid modular products, which provide insulation and supporting constructional elements at the same time are available on the market, none of them provides heating and/or cooling systems integrated with supporting constructional elements.

[0013] The present invention therefore provides a modular wall assembly which makes a quick montage of radiant heating system and supporting constructional elements at the same time, enabling time, labor and installation economy, thus low cost.

Objects of the Invention

[0014] One of the prominent objects of the present invention is to provide a modular hybrid wall assembly supplied with temperature adjustment installations.

[0015] Another object of the present invention is to minimize the energy consumption of buildings by optimal development, production, adjustment and montage of radiant heating and/or cooling panels with supporting constructional elements which are proposed for both interior and exterior walls of buildings in a modular manner.

[0016] Another object of the present invention is to provide an optimal adjustment of radiant heating and/or cooling panels with supporting constructional elements which are proposed for both interior and exterior walls of buildings.

[0017] Another object of the present invention is to provide alternative embodiments for improved adjustments which fit to variable requirements and duties including heating, cooling and mechanical support necessities of the buildings regarding the environmental thermal conditions and the position and function of the wall in the building.

[0018] Another object of the present invention is to minimize the financial and time costs of construction by providing climatic installation, insulation, supporting structural elements and internal and external plastering in a complete solution.

[0019] Another object of the present invention is to minimize the static load of the buildings by supplying wall elements with lower densities.

[0020] Another object of the present invention is to eliminate the jacketing requirements in a post constructional phase and eliminating the economic losses and insulation defects caused by difficult workmanship during jacketing.

[0021] Another object of the present invention is to provide condensation control on the wall surfaces while relieving the gas transfer through the walls.

[0022] Another object of the present invention is to provide thermal comfort by heat transfer predominantly via radiation.

[0023] Another object of the present invention is to provide comfortable living spaces via minimizing the factors which harm the thermal comfort; by keeping surfaces in the room at convenient temperatures and maintaining thermal balance conditions between human body and its surroundings.

[0024] Another object of the present invention is to provide improvement to the energy efficiency as an energy transferring system.

[0025] Additional objects can be understood even more clearly by scrutinizing the following specifications and detailed descriptions throughout the text.

Summary of the Invention

[0026] The present invention relates to a hybrid wall assembly module for use in construction of buildings comprising a fore plate, a main constructional element and a heat exchanger system having a number of pipes serving as conduits for a heating or cooling fluid, wherein the pipes are placed in-between said fore plate and main constructional element, and said fore plate, heat exchanger system and main constructional element being fixedly attached to form a modular and integral wall module adapted to form a hybrid wall assembly. Said module further comprises a recess and protrusion in each vertical end of said module for snap fitting of one module to an-

other so as to form said hybrid wall assembly. The invention also pertains to a modular hybrid wall assembly comprising at least two of the aforesaid modules.

5 Brief Description of the Figures

[0027] Accompanying drawings are given solely for the purpose of exemplifying a hybrid wall assembly whose advantages over prior art were outlined above and will be explained in detail hereinafter:

Fig. 1 demonstrates an exploded view (a) and cross-section view (b) of an embodiment for the hybrid wall assembly module according to the present invention.

Fig. 2 demonstrates an exploded view (a) and cross-section view (b) of another embodiment for the hybrid wall assembly module according to the present invention.

Fig. 3 demonstrates an exploded view (a) and cross-section view (b) of another embodiment for the hybrid wall assembly module according to the present invention.

Fig. 4 demonstrates an exploded view (a) and cross-section view (b) of another embodiment for the hybrid wall assembly module according to the present invention.

Fig. 5 demonstrates an exploded view (a) and cross-section view (b) of another embodiment for the hybrid wall assembly module according to the present invention.

Fig. 6 demonstrates a perspective view and detail of another embodiment for the hybrid wall assembly module according to the present invention.

Fig. 7 demonstrates a perspective view and detail of another embodiment for the hybrid wall assembly module according to the present invention, wherein perspective view and detail of the piping montage is schematically shown on the hybrid panel.

Fig. 8 demonstrates an exemplary arrangement of the hybrid wall assembly formed by two modules according to an embodiment of the present invention.

Fig. 9 demonstrates another exemplary arrangement of the hybrid wall assembly formed by two modules according to an embodiment of the present invention.

55 Detailed Description of the Invention

[0028] Referring now to the figures outlined above, the invented modular hybrid wall assembly is designed to

have extreme flexibility according to the environmental conditions and desired specifications.

[0029] An exploded view (a) and cross-section view (b) of an embodiment for the hybrid wall assembly module (23) according to the present invention is shown in Figure 1. The module (23) comprises a channeled internal insulation material (4) with open profile pipe channels (16) on it; a radiation plate (2) to be furnished before the insulation material (4) which again includes open profile pipe channels (15) and which can be formed according to the pipe geometry; a pipe (3) to be located between the open profile pipe channels (16) on the insulation material (4) and those on the radiation plate (2); a fore plate (1) with open profile pipe channels (14) thereon, which is the complementary item of the panel structure; wall main constructional element (5); external insulation (7) external plaster (8) and chemical adhesives to fix the aforementioned parts together.

[0030] The height and width of the panel module (23) vary according to the floor height and room dimensions on the architectural project. The wall main constructional element (5), external plaster (8) and external insulation (7) thicknesses also vary according to the architectural project requirements and selected materials. Aluminium foil can be utilized as radiation plate (2) material to provide a more even temperature distribution throughout the wall surface.

[0031] The distances between pipes (3) and the thickness of insulation material (4) can be considered as functions of heat load on the building and of the properties of several materials used in the wall module (23). Any insulation materials e.g. XPS (extruded polystyrene), EPS (expanded polystyrene) or rock wool can be utilized in modular hybrid wall assembly modules (23) which are subject to the invention.

[0032] The pipe (3) material is preferably selected from plastic derivatives e.g. PE (polyethylene) or PP (polypropylene). The pipes (3) can be distributed between the open profile pipe channels (14) on the fore plate (1) and the open profile pipe channels (16) on the insulation (4); or as an alternative, they can be located exclusively in the fore plate (1). The geometrical properties of the pipes (3) e.g. diameters and wall thicknesses can be varied according to the embodiment and selected wall assembly system. Void volumes can be allocated in the module (23) for sanitary and wiring installations.

[0033] Another embodiment for the modular hybrid wall assembly module (23) is shown in Figure 2. In this embodiment a hybrid wall system is assembled using wall blocks (10) in the form of bricks made of alternative materials, i.e. kiln, pumice concrete, autoclaved aerated concrete can be utilized as the main constructional element instead of monoblock supporting elements. Pipes (3) are located into closed profile pipe channels (17) in a drywall fore plate (9). An unchanneled internal insulation material (6) can be located behind the fore plate (9) in order to prevent heat flow between the wall and the pipes (3). The panel assembly module (23) comprising

the fore plate (9), pipes (3) and the unchanneled internal insulation material (6) that are to be mounted to the wall blocks (10) used as the main construction element. The montage is to be completed after attaching the external insulation (7) and external plaster (8).

[0034] Another embodiment, which is shown in Figure 3, is the hybrid wall assembly module (23) where a sandwich insulation wall material with filling is employed. This embodiment also comprises a panel system with pipes (3), an unchanneled internal insulation material (6) and a fore plate (9) with closed profile pipe channels (17); along with a sandwich wall main constructional element (11), an isolated sandwich light construction element made of a convenient intermediate insulation material (12) and an external plaster (8).

[0035] Another embodiment, which is shown in Figure 4, comprises a module (23) with pipes (3), unchanneled internal insulation material (6), fore plate (9) with closed profile pipe channels (17); a low heat transfer coefficient main constructional element (13) and an external plaster (8). Here, the utilization of a low heat transfer coefficient main constructional element (13) eliminates the necessity for additional external insulation layers, thus simplifying the assembly.

[0036] Another embodiment, which is shown in Figure 5, differs from the latter embodiment with the removal of the internal insulation behind the panel module (23). This module (23) comprises pipes (3), a fore plate (9) with closed profile pipe channels (17), a main constructional element (13) with low heat transfer coefficient and an external plaster (8).

[0037] Another embodiment shown in Figure 6 is based on a different context compared to the aforementioned assemblies. The radiant module (23) comprises a fore plate (9) with closed profile pipe channels along with an unchanneled internal insulation material (6), and the supporting constructional elements are implemented through a supporting profile (18). This profile (18) offers a void space (19) between the radiant panel and the supporting constructional elements. The void space (19) serves with extra thermal insulating properties and enhances the humidity optimization.

[0038] Figure 7 schematically demonstrates the piping montage of the hybrid wall element. Hybrid wall modules (23) are mounted to the hybrid panel montage profiles (20). In this manner, adjacent layers of the hybrid wall assembly modules (23) of any of the aforementioned embodiments are to be combined and set up. Said montage profiles (20) enable robust fixation of the modules (23) in horizontal direction.

[0039] In preferred embodiments, the lower partitions of the wall assembly lack heating /cooling panels in order to reserve space for distribution and collection fittings for fluid flowing through the pipes. In order to obtain surfaces compatible with the rest of the wall assembly, installation of the fittings is to be followed by covering of these partitions with cover panels (28), which do not comprise pipes.

[0040] As comprehensively shown in Figure 7, conditioned fluid inlet (26) to the panels and conditioned water outlet (27) from the panels are fitted to the main distributor return line (25) and main distributor departure line (24), respectively. Thus, the fluid circuit is closed. Among many other alternative junction fittings, use of splitting (29) and combining (30) T fittings are possible for distribution and collection of conditioned fluid throughout the invented modular hybrid wall modules (23) and assembly, but it is not limited with those two fittings.

[0041] The advantageous structure of the hybrid wall assembly modules (23) enabling easy to fit connection therebetween forms a further aspect of the present invention. Figure 8 shows the montage of an embodiment of the hybrid wall assembly as described above with the help of Figure 3. Figure 8 (a) and (b) show perspective view with detail and horizontal cross section representation of the assembly to provide an explicit comprehension of the montage in snap fitting manner. The figure shows the montage of two hybrid wall modules (23) by interference of the protrusion of the module (23) on the right hand side into a recess of the module on the left hand side. The contact surfaces (31, 32) between the said protrusion and recess may be reinforced using chemical adhesives for enhanced substantiality. Each of the modules (23) comprises a longitudinal recess (41) in one end, and a longitudinal protrusion (42) on the opposite end extending through the vertical direction (y) for modular snap fitting between numerous wall modules (23). This object can be achieved, for instance by axial shift of any intermediate layer, i.e. insulation material (11) in horizontal direction (x) such that the recess (41) and protrusion (42) as referred might appear in the end sections of the module (23). Those skilled in the art would readily appreciate that these recess (41) and protrusion (42) sections may alternatively be formed by axial displacement of the main constructional element (11) or by way of suitably sizing any intermediate layer of the module structure.

[0042] Figure 9 shows another montage embodiment of the aforesaid hybrid wall assembly. Figure 9 (a) and (b) show perspective view with detail and horizontal cross section representation of the assembly to provide an explicit comprehension of the montage in snap on manner. The figure shows the montage manner of the hybrid wall assembly by arranging matching modules by fitting relatively protruding and recessing levels together. The contact surfaces (33, 34) between the modules (23) may be reinforced using chemical adhesives for enhanced substantiality. In this embodiment, one or a group of layers are axially shifted relative to the rest of construction elements so that the aforesaid protrusion (42) and recess (41) parts would be formed in longitudinal end sections.

[0043] As a further aspect, in the snap fitting region (A) as depicted in Figures 8 and 9 provided is the perpendicular contact surface(s) (31) of the collateral modules (23) which are not linear such that horizontal contact surfaces (32) are formed by virtue of the snap fitting structure. This arrangement may easily be achieved through,

for instance by way of the axial displacement of any intermediate layer of the modules (23) in horizontal direction (x) as explained above.

[0044] The wall assembly modules (23) which are to be produced beforehand are then aligned one by one between the profiles attached to the floor and ceiling. Juxtapositioning walls are easily fixed to each other in a snap fitting manner. The radiant panels are thermally conditioned by means of the circulated water from the distributive and collective lines in the dedicated lower partition. The installation of the fittings is followed by obtaining compatible surfaces with the cover panel (28) which does not comprise pipelines. The predominantly radiative heat flows via the fore plate due to the heating / cooling fluid flowing through the pipes (3). Internal insulation materials (4,6) behind radiation plates (2) as mentioned in certain embodiments aim to minimize the heat losses through the wall assembly. The supporting main constructional elements (5, 10, 11 and 13) serve as the main body of the modular hybrid wall assembly. The distance of the insulation material (4, 6) from the wall assembly surface can depend on the project design necessities. The insulation material can either be placed around the middle of the layers constituting the wall assembly, or they can be placed near any of the both surfaces of the assembly.

[0045] The materials to be used in the invented hybrid modular wall assembly, their positioning and thicknesses, distances between pipes, dimensions of the wall modules and embodiments may vary according to the constructional, thermal and economical optimization necessities of related projects.

[0046] By means of the invented modular hybrid wall assembly addressed above, the separation of indoor spaces and construction of external walls is obtained along with an efficient radiant heating / cooling system. This hybrid assembly presents a complete solution for technical problems including climatization, construction and insulation as well as robust fitting in between separate modules (23).

Claims

1. A hybrid wall assembly module (23) for use in construction of buildings comprising a fore plate (1, 9), a main constructional element (5, 10, 11, 13) and a heat exchanger system having a number of pipes (3) serving as conduits for a heating or cooling fluid, wherein the pipes (3) are placed in-between said fore plate (1, 9) and main constructional element (5, 10, 11, 13), and said fore plate (1, 9), heat exchanger system and main constructional element (5, 10, 11, 13) being fixedly attached to form an integral wall module (23) adapted to form a hybrid wall assembly; and wherein the module (23) further comprises a recess (41) and protrusion (42) in vertical ends thereof extending along vertical direction (y) for snap fitting

- of one module to another so as to form a modular hybrid wall assembly.
2. A module (23) according to claim 1 further comprising an insulation material (4, 6) between the piping (3) and main constructional element (5, 10, 11, 13). 5
 3. A module (23) according to claim 2 wherein the fore plate (1) and insulation material (4) comprise open profile channels (14, 16) for receiving the said piping (3). 10
 4. A module (23) according to claim 1 wherein the fore plate (9) comprises closed profile through channels (17) for receiving the said piping (3). 15
 5. A module (23) according to claim 1 further comprising at least one of an intermediate insulation material (12) and an external insulation material (7). 20
 6. A module (23) according to claim 1 further comprising a plaster layer (8) in outermost section of the module (23).
 7. A module (23) according to claim 1 wherein the main constructional element (5, 10, 11, 13) is in the form of a monoblock supporting element or bricks. 25
 8. A module (23) according to claim 1 further comprising a radiation panel (2) having open profile pipe channels (15) which panel is placed between the fore plate (1, 9) and pipes (3). 30
 9. A module (23) according to claim 8 wherein the radiation panel (2) is in the form of an aluminum foil. 35
 10. A module (23) according to claim 1 further comprising a void layer (19) formed by a number of profiles (18) between the piping (3) and main constructional element (5, 10, 11, 13). 40
 11. A module (23) according to claim 1 further comprising a montage profile (20) adapted to engage two collateral modules (23) from upper- and lowermost horizontal ends thereof. 45
 12. A module (23) according to claim 2 or 5 wherein at least one of the layers of main constructional element (5, 10, 11, 13) and insulation material (4, 6, 7, 12) is axially shifted relative to the rest of the layers in horizontal direction (x) such that a recess (41) and protrusion (42) in vertical ends of said module (23) extending along the vertical direction (y) for snap fitting of one module (23) to another are formed. 50
 13. A module (23) according to claim 1 wherein the pipes (3) are made of plastic. 55
 14. A modular hybrid wall assembly comprising a module (23) according to any of the preceding claims.
 15. A modular hybrid wall assembly according to claim 14 wherein the assembly comprises a snap fitting region (A) having perpendicular and horizontal contact surfaces (31, 32) between two modules (23), said perpendicular contact surface(s) (31) is arranged not to be linear along the cross-section of the module (23) for reinforcement of the assembly.

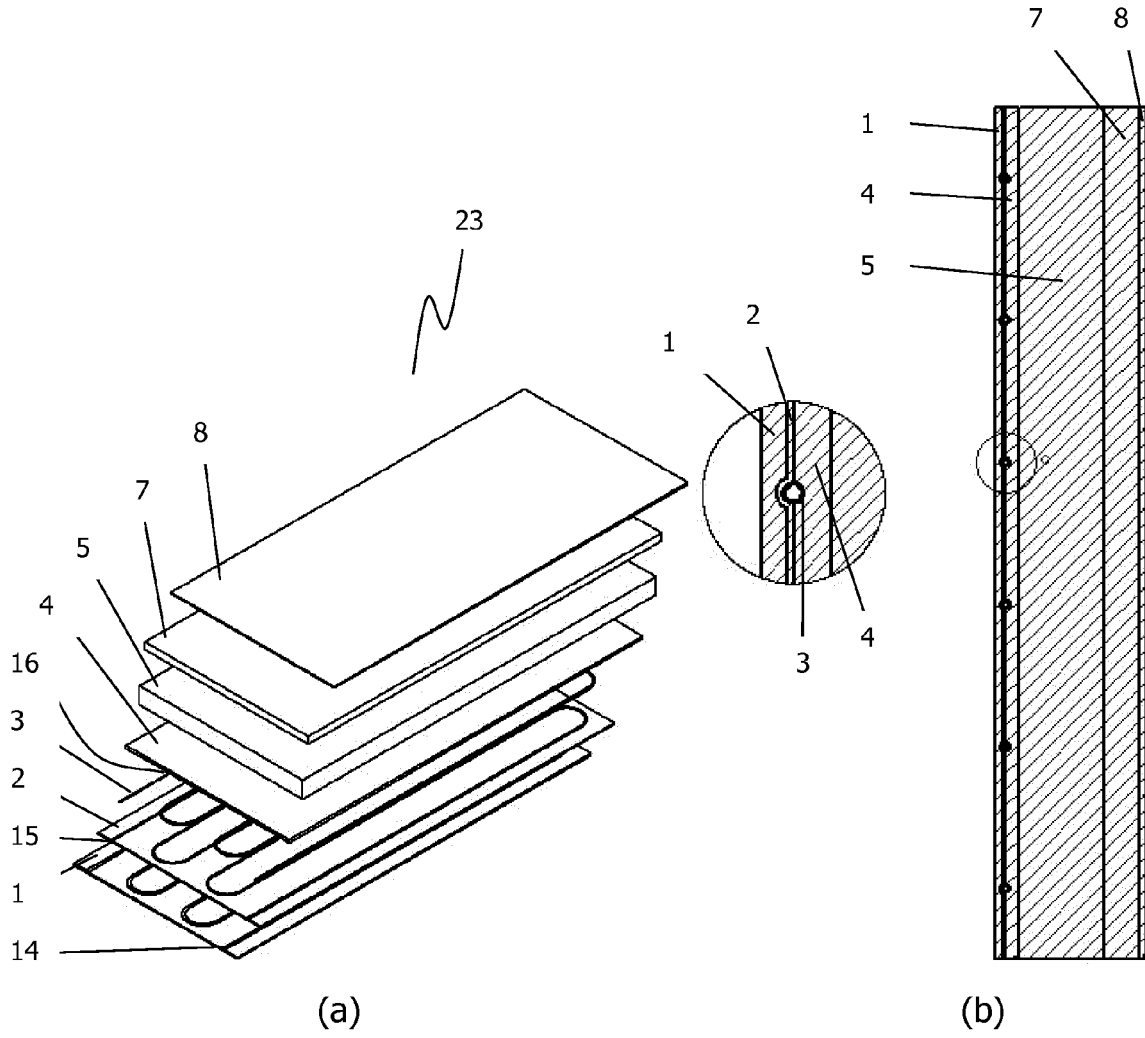

Figure 1

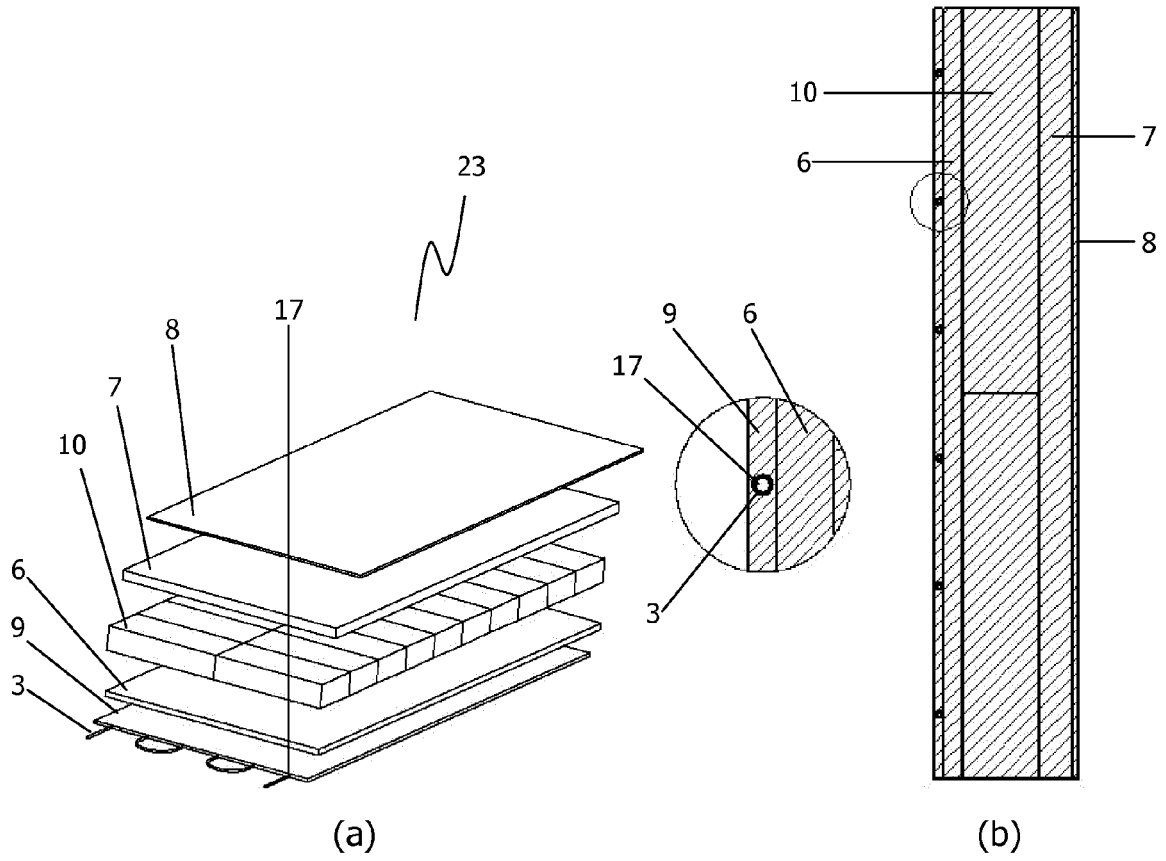

Figure 2

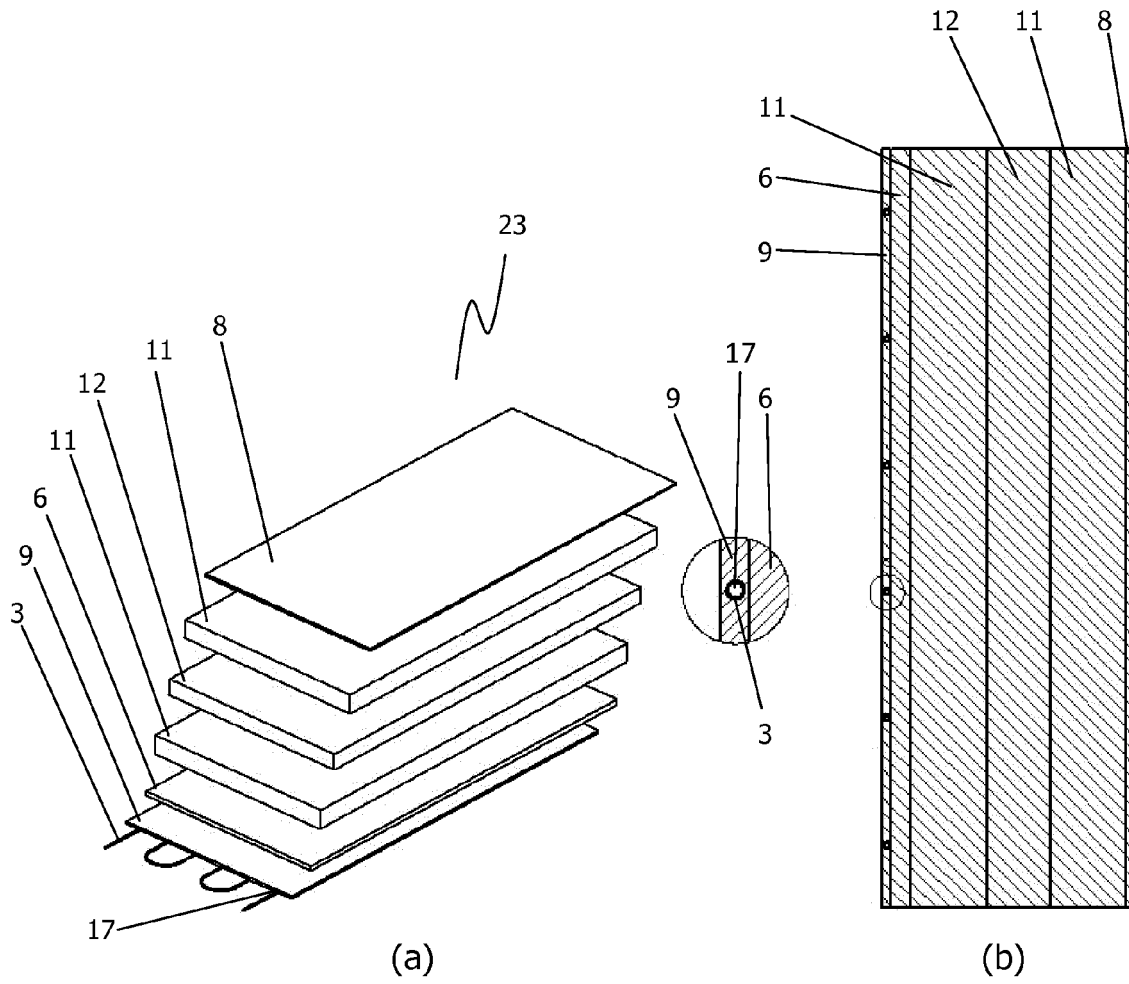

Figure 3

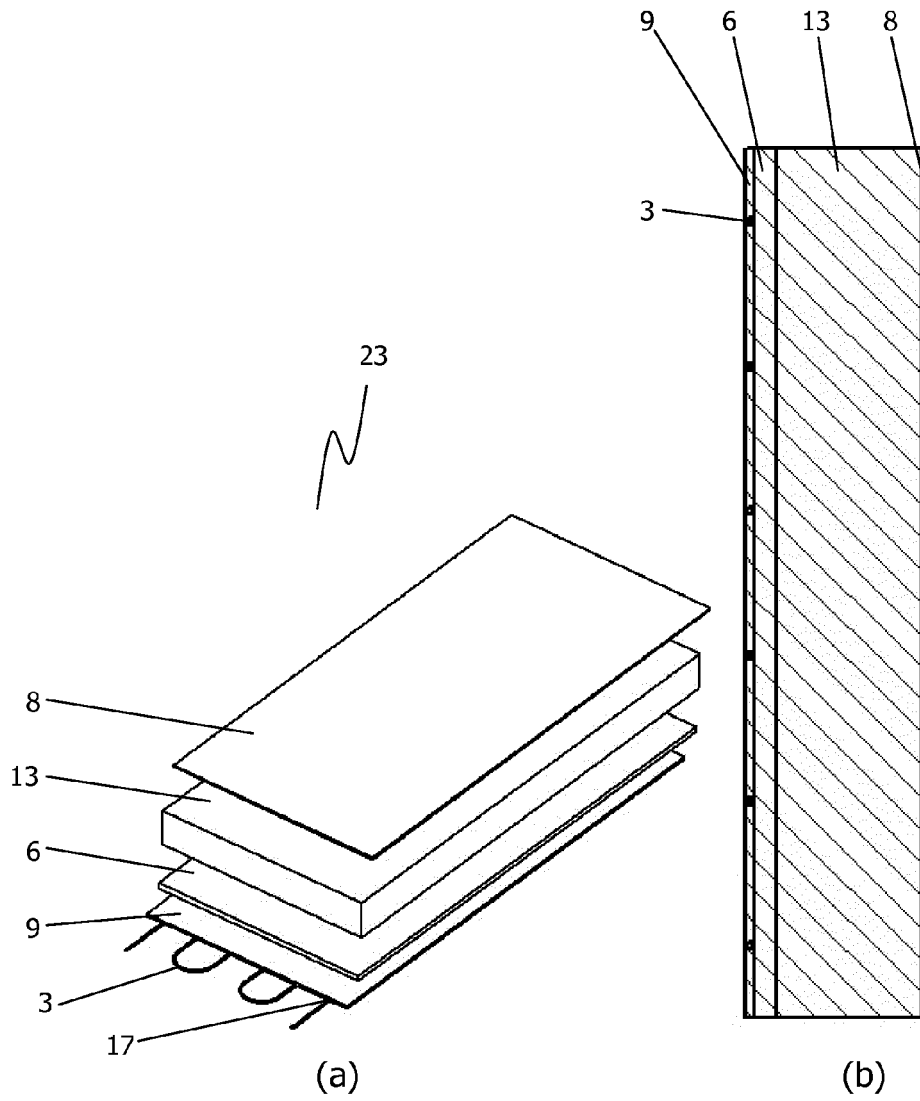

Figure 4

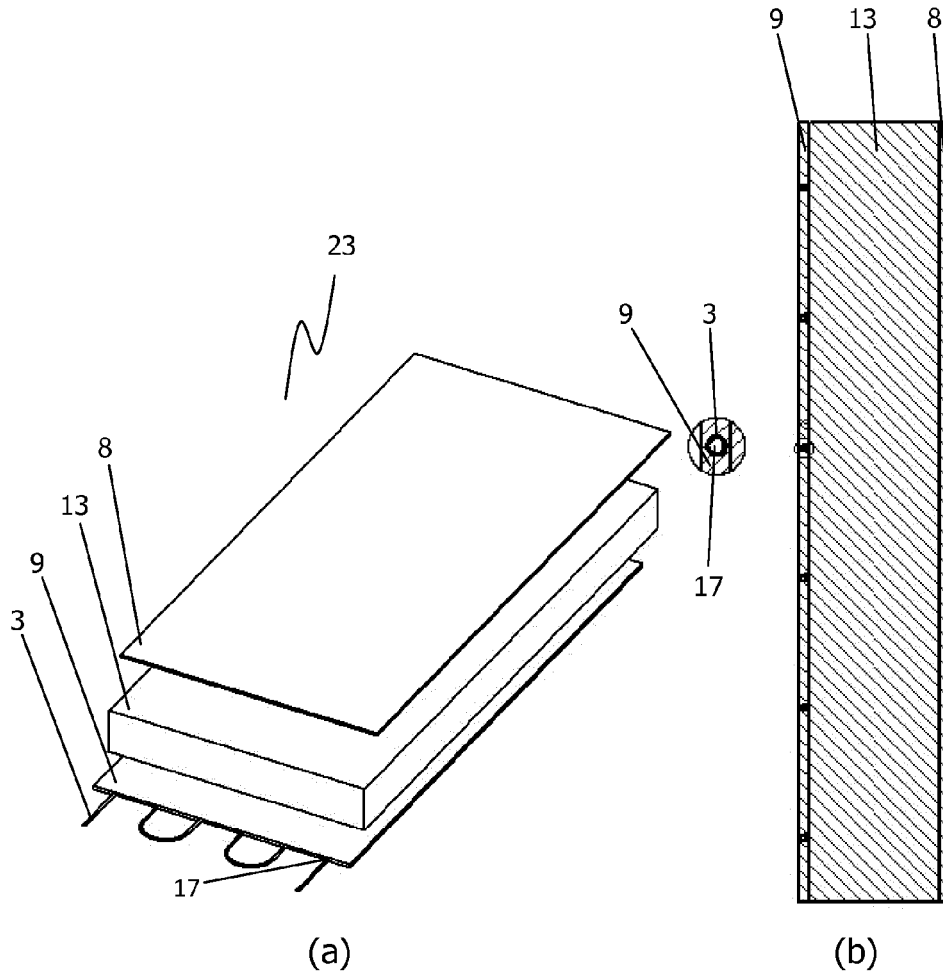

Figure 5

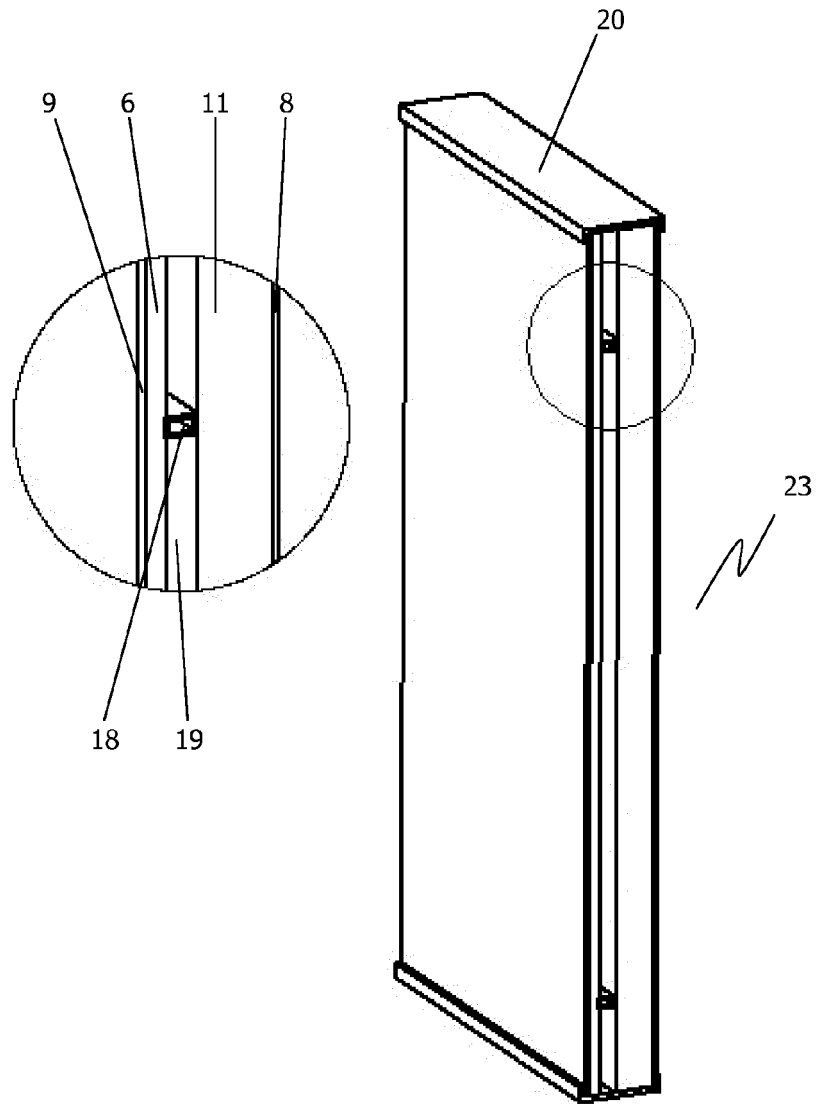

Figure 6

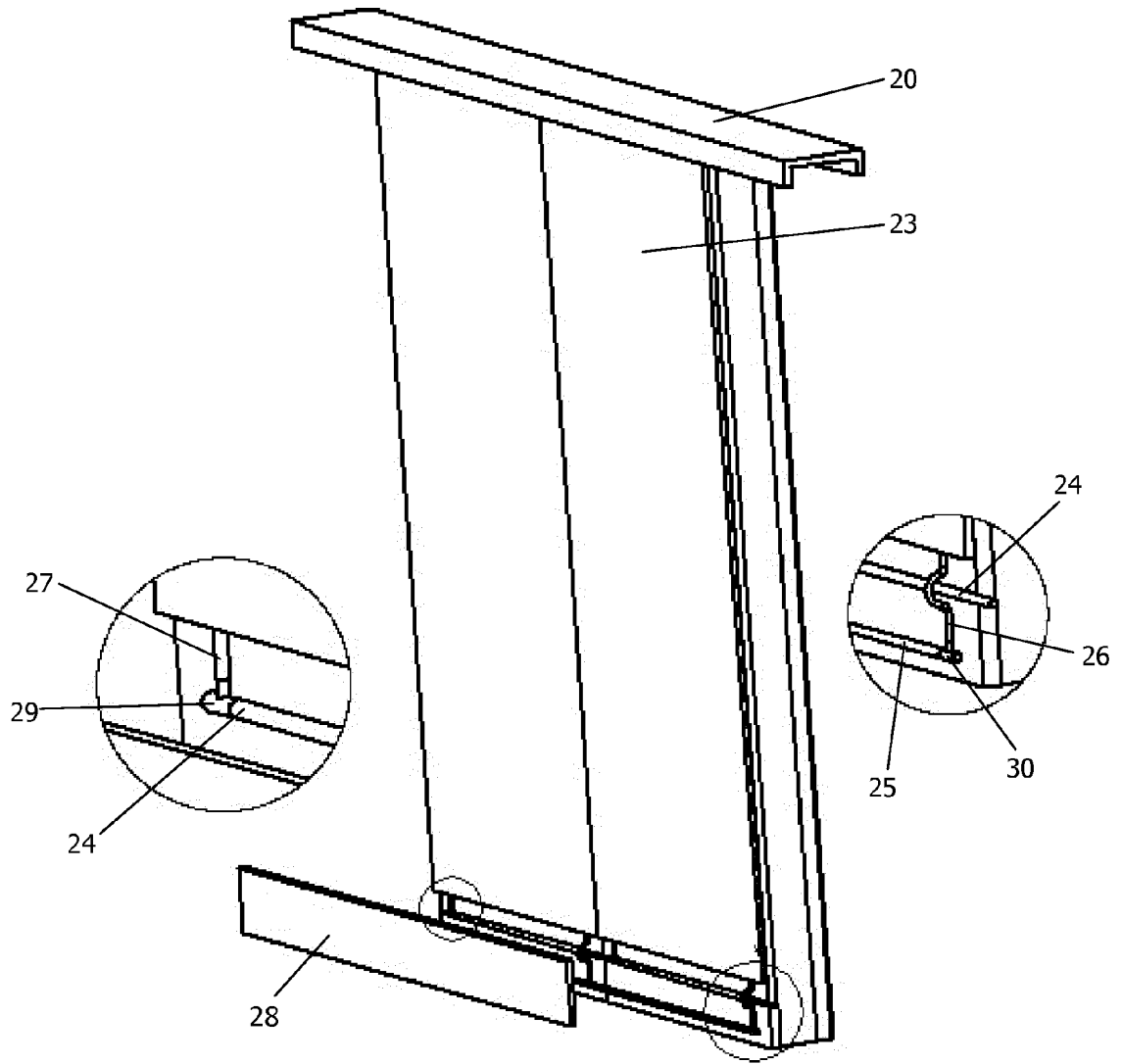

Figure 7

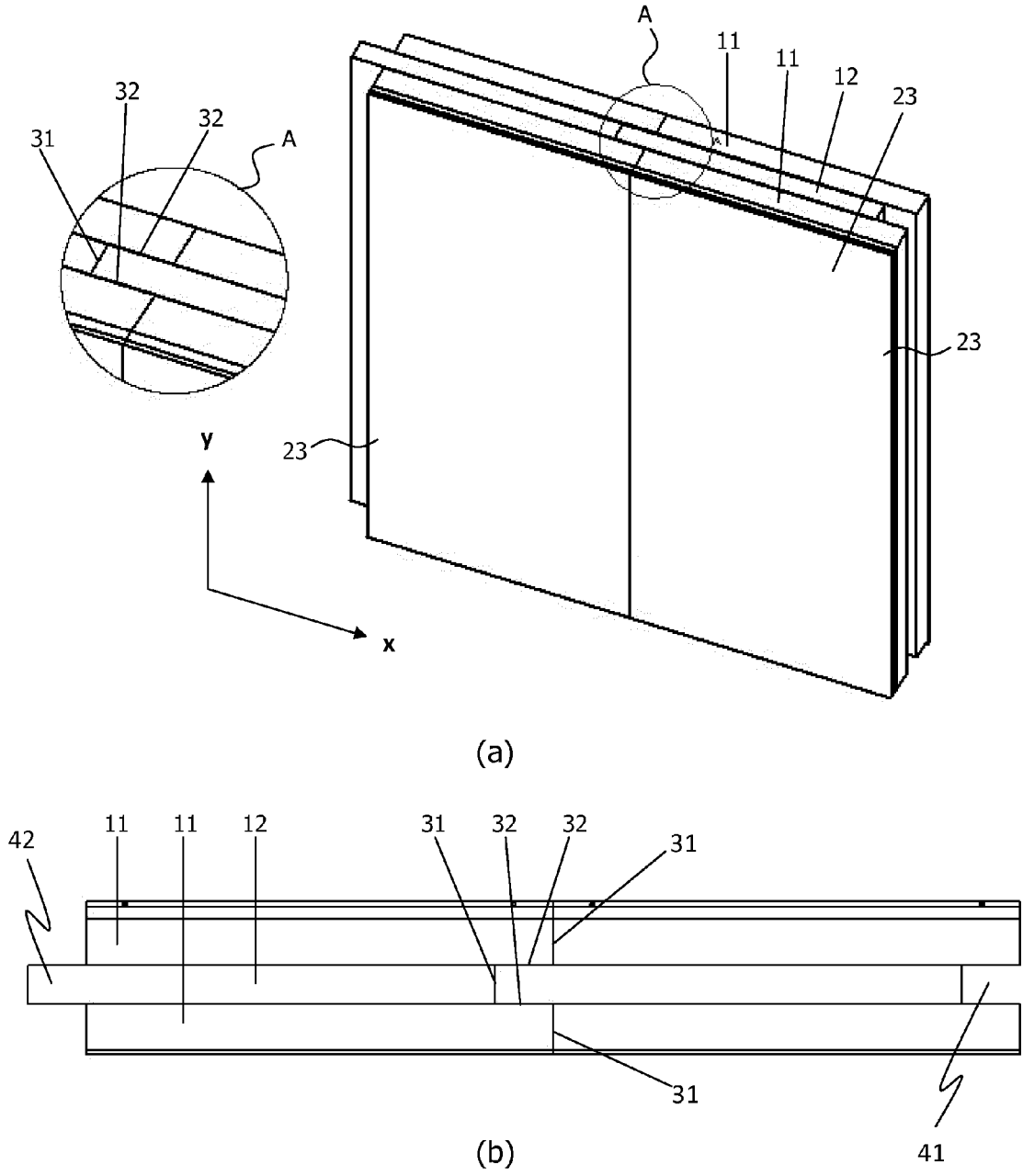

Figure 8

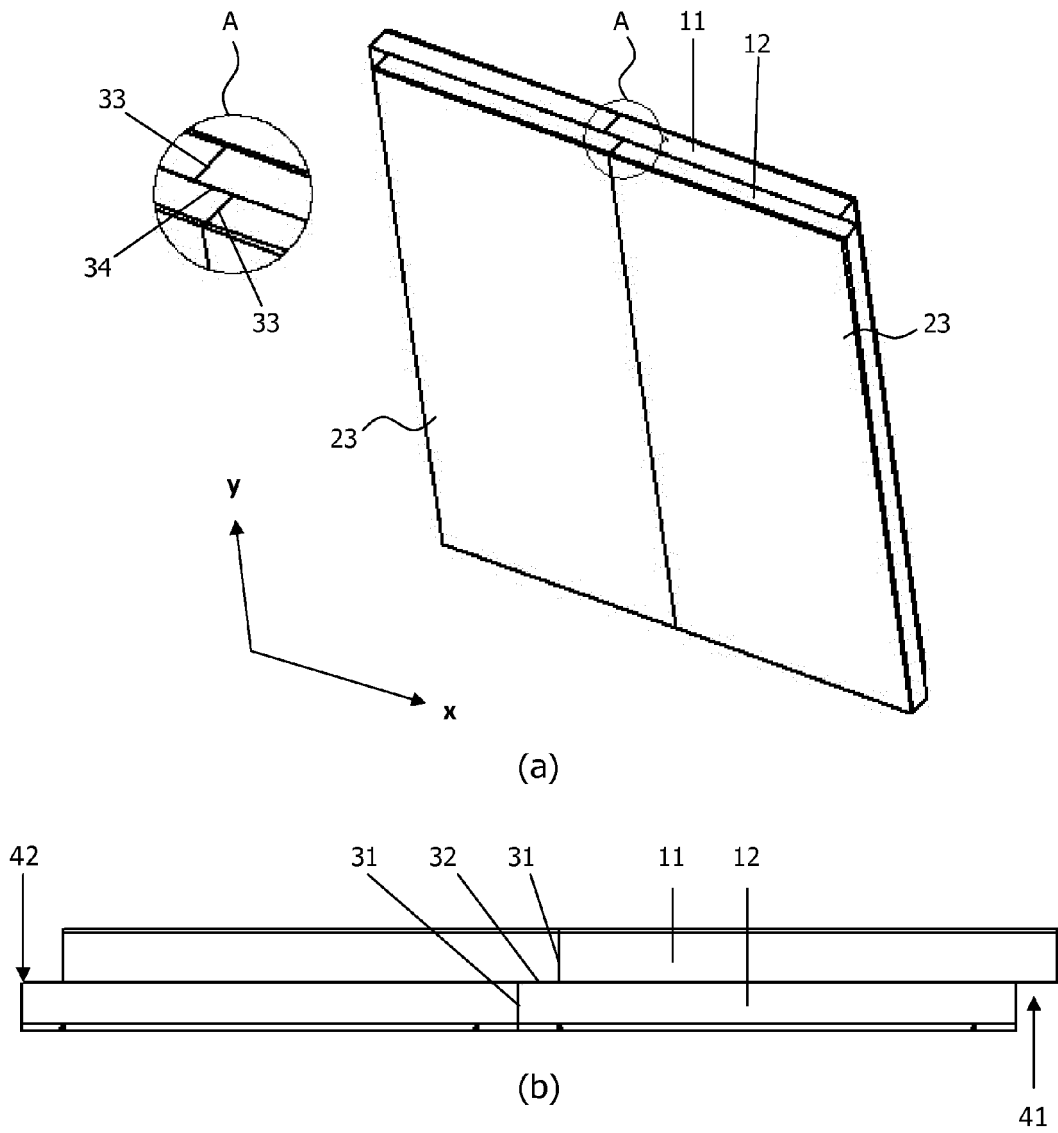

Figure 9



EUROPEAN SEARCH REPORT

Application Number
EP 12 18 3746

DOCUMENTS CONSIDERED TO BE RELEVANT			
Category	Citation of document with indication, where appropriate, of relevant passages	Relevant to claim	CLASSIFICATION OF THE APPLICATION (IPC)
Y	DE 20 2011 104258 U1 (CRH ALBERT GMBH [DE]) 15 November 2011 (2011-11-15) * paragraph [0033] - paragraph [0049]; claims 1-3,5; figures 1-4 * -----	1,7,13, 14	INV. E04C2/52
Y	EP 1 001 234 A2 (NUEDLING FRANZ C BASALTWERK [DE]) 17 May 2000 (2000-05-17) * paragraphs [0015], [0021]; figures 1,3,4 * -----	1,7,13, 14	
			TECHNICAL FIELDS SEARCHED (IPC)
			E04C F24D
The present search report has been drawn up for all claims			
Place of search The Hague		Date of completion of the search 18 February 2013	Examiner Mysliwetz, Wolfgang
CATEGORY OF CITED DOCUMENTS X : particularly relevant if taken alone Y : particularly relevant if combined with another document of the same category A : technological background O : non-written disclosure P : intermediate document		T : theory or principle underlying the invention E : earlier patent document, but published on, or after the filing date D : document cited in the application L : document cited for other reasons & : member of the same patent family, corresponding document	

1
EPC FORM 1503 03 82 (P04C01)

**ANNEX TO THE EUROPEAN SEARCH REPORT
ON EUROPEAN PATENT APPLICATION NO.**

EP 12 18 3746

This annex lists the patent family members relating to the patent documents cited in the above-mentioned European search report. The members are as contained in the European Patent Office EDP file on
The European Patent Office is in no way liable for these particulars which are merely given for the purpose of information.

18-02-2013

Patent document cited in search report	Publication date	Patent family member(s)	Publication date
DE 202011104258 U1	15-11-2011	DE 202011104258 U1	15-11-2011
		EP 2557248 A1	13-02-2013

EP 1001234 A2	17-05-2000	DE 19852063 A1	18-05-2000
		EP 1001234 A2	17-05-2000

EPO FORM P0459

For more details about this annex : see Official Journal of the European Patent Office, No. 12/82

REFERENCES CITED IN THE DESCRIPTION

This list of references cited by the applicant is for the reader's convenience only. It does not form part of the European patent document. Even though great care has been taken in compiling the references, errors or omissions cannot be excluded and the EPO disclaims all liability in this regard.

Patent documents cited in the description

- AT 405429 A [0007]
- EP 2397322 A2 [0007]