



(11) **EP 2 706 284 A1**

(12) **EUROPEAN PATENT APPLICATION**

(43) Date of publication:
12.03.2014 Bulletin 2014/11

(51) Int Cl.:
F21S 8/02 (2006.01) F21V 17/16 (2006.01)

(21) Application number: **13181904.7**

(22) Date of filing: **27.08.2013**

(84) Designated Contracting States:
AL AT BE BG CH CY CZ DE DK EE ES FI FR GB GR HR HU IE IS IT LI LT LU LV MC MK MT NL NO PL PT RO RS SE SI SK SM TR
Designated Extension States:
BA ME

(71) Applicants:
• **OSRAM GmbH**
80807 München (DE)
• **OSRAM S.P.A. - SOCIETA' RIUNITE OSRAM EDISON CLERICI**
20126 Milano (IT)
Designated Contracting States:
IT

(30) Priority: **05.09.2012 IT TO20120767**

(72) Inventor: **Martini, Michele**
30038 Spinea, VE (IT)

(54) **System for mounting lighting devices and corresponding device**

(57) A system for mounting a recessed lighting source, for example of the LED type, in an aperture (A) includes:

- an annular fixing member (10) for fitting to the aperture (A), and
- a lighting body (12) surrounded by a collar member (14). The lighting body (12) is insertable into the annular fixing member (10), with one of the annular fixing member (10) and the collar member (14) carrying one or more jaws (20) movable between:
 - an engaged position, in which the jaws (20) block the collar member (14) with respect to the annular fixing member (10) to fix the lighting body (12) to the aperture (A), and
 - a disengaged position, in which the relative movement of the collar member (14) and of the lighting body (12) with respect to the annular fixing member (10) is not impeded by the jaws (20).

FIG. 1

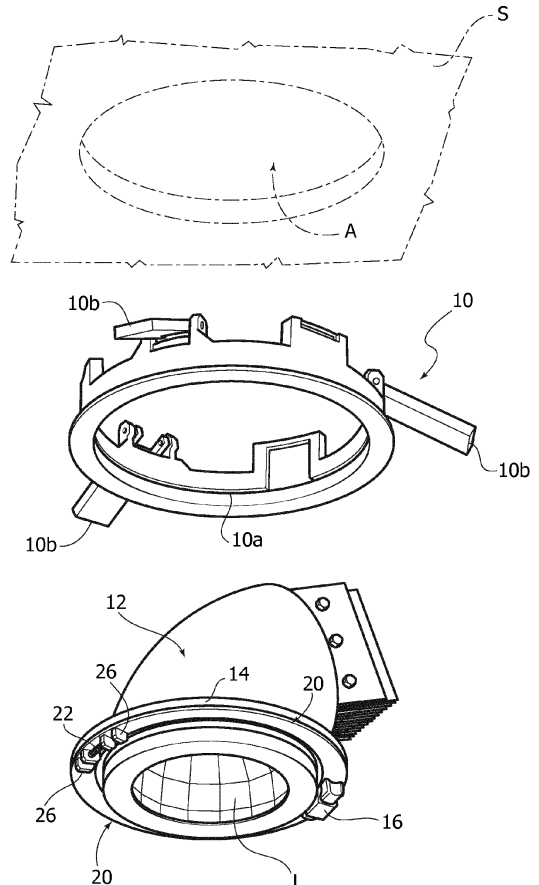

EP 2 706 284 A1

Description

Technical field

[0001] The present description relates to the mounting of lighting devices.

[0002] Various embodiments can relate to the installation of recessed lighting devices.

Technical background

[0003] Various solutions are known which make it possible to mount and uninstall, i.e. to install and remove, recessed lighting devices (luminaires) intended to be mounted, for example, in a ceiling or false ceiling.

[0004] These are systems which are rather complex, in particular in view of the possible application for lighting devices which can be tilted and/or oriented.

Object and summary

[0005] There is therefore a need to provide systems which can allow for and facilitate the mounting, the uninstalling and/or the adjustment of recessed lighting devices, which may be tiltable and/or orientable.

[0006] It is an object of various embodiments to satisfy this need.

[0007] Various embodiments can achieve this object owing to a system having the features indicated specifically in the claims which follow. Various embodiments also relate to a corresponding device.

[0008] The claims form an integral part of the technical teaching provided here in relation to the invention.

[0009] Various embodiments make it possible to rapidly mount and uninstall, and also possibly adjust, a recessed lighting device, which may be tiltable and/or orientable.

[0010] In various embodiments, the core of the lighting device can be removed from the mounting structure (for example a ceiling or a false ceiling) without it being necessary to completely remove the fixing system.

[0011] In various embodiments, it is thus possible, for example, to rapidly and easily carry out maintenance and/or cleaning operations for the lighting device, with the possibility to reposition the latter easily in the mounted state.

[0012] In various embodiments, the core of the lighting device can bear a collar member, which is provided with two symmetrical jaws that are able to cooperate (in a way which can be grossly assimilated with the operation of the jaws of a drum brake) with an annular fixing member mounted beforehand in the installation structure (for example a ceiling or false ceiling).

[0013] In various embodiments, by returning the jaws towards one another, thus determining the radial contraction of the annular body jointly defined thereby, it is possible to insert the lighting device into the annular fixing member provided in the mounting structure; by releasing

the jaws, these can thus return (for example because of an elastic member interposed therebetween) to a radially expanded condition, in which they block the collar member, and therefore the lighting device, with respect to the annular fixing member.

[0014] In various embodiments, both the collar member and the annular fixing member can have a circular shape, whereby, by returning the jaws slightly from the blocking position, it is possible to rotate the lighting device with respect to the annular fixing member, it then being possible to adjust the direction in which the light radiation is projected.

Brief description of the figures

[0015] Various embodiments will now be described, purely by way of non-limiting example, with reference to the accompanying figures, in which:

- figure 1 shows, in an ideal exploded perspective view, components of embodiments,
- figure 2 shows, once again in an ideal exploded perspective view, parts of components of embodiments,
- figures 3 to 6, where figures 5 and 6 can be grossly assimilated with sectional views along the line V-V in figure 3 shown on an enlarged scale, illustrate operating criteria of embodiments.

Detailed description

[0016] In the following description, various specific details aimed at providing a fuller understanding of various embodiments are explained. The embodiments may be implemented without one or more of the specific details or using other methods, components, materials, etc. In other cases, known structures, materials or operations are not shown or described in detail so that the various aspects of the embodiments may be understood more clearly.

[0017] The reference to "an embodiment" in the context of this description indicates that a particular configuration, structure or feature described in relation to the embodiment is included in at least one embodiment. Therefore, phrases such as "in one embodiment", which may occur at various points in this description, do not necessarily refer to the same embodiment. Moreover, particular forms, structures or features may be combined in any suitable manner in one or more embodiments.

[0018] The reference signs used here are provided solely for the sake of convenience and therefore do not define the scope of protection or ambit of the embodiments.

[0019] Various embodiments can relate to a system for mounting recessed lighting sources in an aperture, for example the circular aperture A (see figure 1) provided in a mounting structure such as, for example, a ceiling

or a false ceiling S.

[0020] In various embodiments, the system can include:

- an annular fixing member 10 intended to be fitted to the aperture A in the manner of a sealing frame or collar thereof, and
- a lighting device 12 (what is termed a luminaire) which can receive a light radiation source L, such as for example an LED "spotlight".

[0021] Even though it is represented for clarity of illustration and is intended to be inserted into a system according to embodiments, the light radiation source L is not in itself an essential component of the embodiments.

[0022] The lighting device 12 can be of any known type; it may be, for example, an adjustable and/or orientable lighting device as described in a patent application for industrial invention filed on the same date in the name of the same applicants.

[0023] In various embodiments, the body of the lighting device 12 is surrounded by a collar member 14. The collar member 14 is intended to support the body of the lighting device 12, being fixed thereto with any known means or, possibly, being realized in one piece therewith.

[0024] In various embodiments, the collar member 14 can be of the type shown in figure 2, including a circular ring body provided with a ring of lightening and/or ventilation apertures.

[0025] In various embodiments, the collar member 14 can have a body 16 for the mounting of an orientation device of the lighting device 12.

[0026] In various embodiments, the member 14 can be provided, for example in the vicinity of the body 16, with pins 18 or similar fixing and joint formations for a pair of jaws 20 having C-shaped, complementary structures, so as to jointly define an (open) annular body which is substantially coextensive with the collar member 14.

[0027] In various embodiments, the two jaws 20 can have:

- a first pair of homologous ends 20a, positioned adjacent to one another and situated at a fixed distance, intended to be mounted on the pins or similar mounting formations 18 provided on the collar member 14,
- a second pair of homologous ends 20b, adjacent to one another and situated at a variable distance as a result of the oscillation of the jaws 20 around the pins or similar mounting formations 18.

[0028] In various embodiments, when they are mounted on the collar member 14 (for example owing to the pins or similar mounting formations 18), the two jaws 20 jointly define a radially contractible and expandable annular body.

[0029] In various embodiments, in order to avoid uncontrolled spreading and/or detachment of the jaws 20 from the collar member 14 which bears them, the spread-

ing movement of the jaws 20 can be stopped by stop formations (not explicitly visible in the drawings) associated with the pins 18 (or possibly with the body 16).

[0030] In various embodiments, a helical spring 22 can be interposed between the ends 20b of the second pair, said helical spring acting as an elastic return member for the jaws in conditions in which the ends 20b move apart, thus in a radially expanded state of the annular body jointly defined by the jaws 20.

[0031] In various embodiments, at the second homologous ends 20b (those between which the spring 22 is interposed in the exemplary embodiment considered here), provision can be made of protruding tongues 26, which can be grasped and moved closer together ("pinched"), so as to move the two jaws 20 closer together and determine radial contraction of the annular body jointly defined thereby. By releasing the tightening or pinching action exerted on the tongues 26, the spring 22 acts so as to spread apart the second ends 20b, causing a controlled widening of the jaws 20 according to a mechanism which can be grossly assimilated with the operating movement of the jaws or shoes of a drum brake.

[0032] In various embodiments, the inner surface of the annular fixing member 10 may have, on the wall of its central orifice (see figure 1), a peripheral groove 10a which can constitute an engagement structure for the jaws 20.

[0033] The sequence of figures 3 and 4 schematically shows the operation for inserting the lighting device 12 into the fixing member 10, which is assumed to have been inserted beforehand into the aperture A according to any solution known for this purpose (for example using elastically spreadable brackets 10b, currently in use for mounting ceiling spotlights).

[0034] Figures 3 and 4 can therefore be considered to be ideal views from below relating to a situation in which the aperture A (see figure 1) is provided in a ceiling or false ceiling S extending in a horizontal direction.

[0035] Figure 3 (and in coordination figure 5) show how, by acting on the tongues 26 and tightening them so as to cause them to move together counter to the reaction force exerted by the spring 22, it is possible to determine the radial contraction of the annular body jointly defined by the jaws 20.

[0036] In these conditions, the lighting device 12 can be inserted into the aperture A, the outline of which is "sealed" by the annular fixing member 10.

[0037] Figure 4 (and in coordination figure 6) show how, by gradually releasing the tongues 26, the spring 22 spreads apart the ends 20b of the jaws, which widen so as to engage in the groove 10a.

[0038] In this way, the collar member 14 (and the lighting device 12 carried thereby) are blocked with respect to the annular fixing member 10, thereby ensuring the fixing of the lighting device 12 (and of the light radiation source L intended to be mounted thereon) in the aperture A in accordance with current mounting methods for recessed lighting sources.

[0039] In various embodiments in which the fixing member 10 and the collar member 14 are circular, by acting on the tongues 26 it is moreover possible to slightly contract the jaws 22, so as to relax the braking/blocking action exerted thereby with respect to the fixing member 10, in such a manner that, even without arriving at the disconnection of the lighting device 12 from the fixing member 10, the lighting device 12 can be made to rotate so as to vary (about a vertical axis in the case of ceiling mounting) the direction in which the light radiation is projected.

[0040] In various embodiments, the ways in which the lighting device 12 is fixed on the collar 14 can moreover make it possible to realize an orientation in the sense of varying the "elevation" of the direction in which the light radiation emitted by the source L is projected: this can take place in accordance with known criteria without this affecting the mode of operation of the embodiments, whatever the solution adopted.

[0041] It will be understood that various embodiments can provide for the presence of a number of jaws 20 which differs from two: for example, it is possible to provide for the presence of a single jaw, intended to realize the mounting mechanism described above.

[0042] Furthermore, instead of being carried by the collar member 14 (preferably outwardly of the lighting body 12), the jaw or the jaws in question could be carried by the annular fixing member 10 and be intended to tighten the collar member 14 with a complementary kinematic arrangement with respect to that illustrated here by way of example.

[0043] As a consequence, without affecting the principle of the invention, the constructional details and embodiments may vary, also significantly, with respect to that illustrated here purely by way of non-limiting example, without thereby departing from the scope of protection of the invention. This scope of protection is defined by the accompanying claims.

Claims

1. A system for mounting a recessed lighting source in an aperture (A), the system including:
 - an annular fixing member (10) for fitting to said aperture (A), and
 - a lighting body (12) surrounded by a collar member (14), said lighting body (12) being insertable into said annular fixing member (10), with one of said annular fixing member (10) and said collar member (14) provided with at least one jaw (20) movable between:
 - an engaged position, in which the at least one jaw (20) blocks the collar member (14) with respect to the annular fixing member (10) to fix the lighting body (12) to the aperture (A), and
 - a disengaged position, in which the relative

movement of the collar member (14) with respect to the annular fixing member (10) is not impeded by the at least one jaw (20).

2. The system as claimed in claim 1, wherein said at least one jaw (20) is elastically urged (22) towards said engaged position.
3. The system as claimed in claim 1 or claim 2, wherein said at least one jaw (20) is carried by the collar member (14) of the lighting body (12).
4. The system as claimed in any of the preceding claims, including a pair of jaws (20) jointly defining a radially expandable and contractible annular body.
5. The system as claimed in claim 4, wherein said jaws (20) have a first pair of homologous ends (20a) at a fixed distance and a second pair of homologous ends (20b) whose distance is variable to radially expand and contract said annular body jointly defined by the jaws (20).
6. The system as claimed in claim 5, including a spring (22) interposed between the homologous ends of said second pair of homologous ends (20b) of the jaws (20) to bias said pair of jaws (20) towards a radially expanded or contracted condition of the annular body jointly defined by the jaws (20).
7. The system as claimed in claim 5 or claim 6, including a pair of tongue formations (26) protruding from the homologous ends of said second pair of homologous ends (20b) of the jaws (20), whereby pinching of said tongue formations (26) produces radial contraction of the annular body jointly defined by the jaws (20).
8. The system as claimed in any of claims 4 to 7, wherein said pair of jaws (20) are mounted on said collar member (14), preferably outwardly of said lighting body (12).
9. The system as claimed in any of the preceding claims, wherein said annular fixing member (10) and said collar member (14) of the lighting body (12) are circular, whereby, with said at least one jaw (20) in said disengaged position, the lighting body (12) is rotatable with respect to the annular fixing member (10).
10. A lighting device (12) for use in the system as claimed in any of claims 1 to 9, wherein said lighting device (12) carries said collar member (14).

FIG. 1

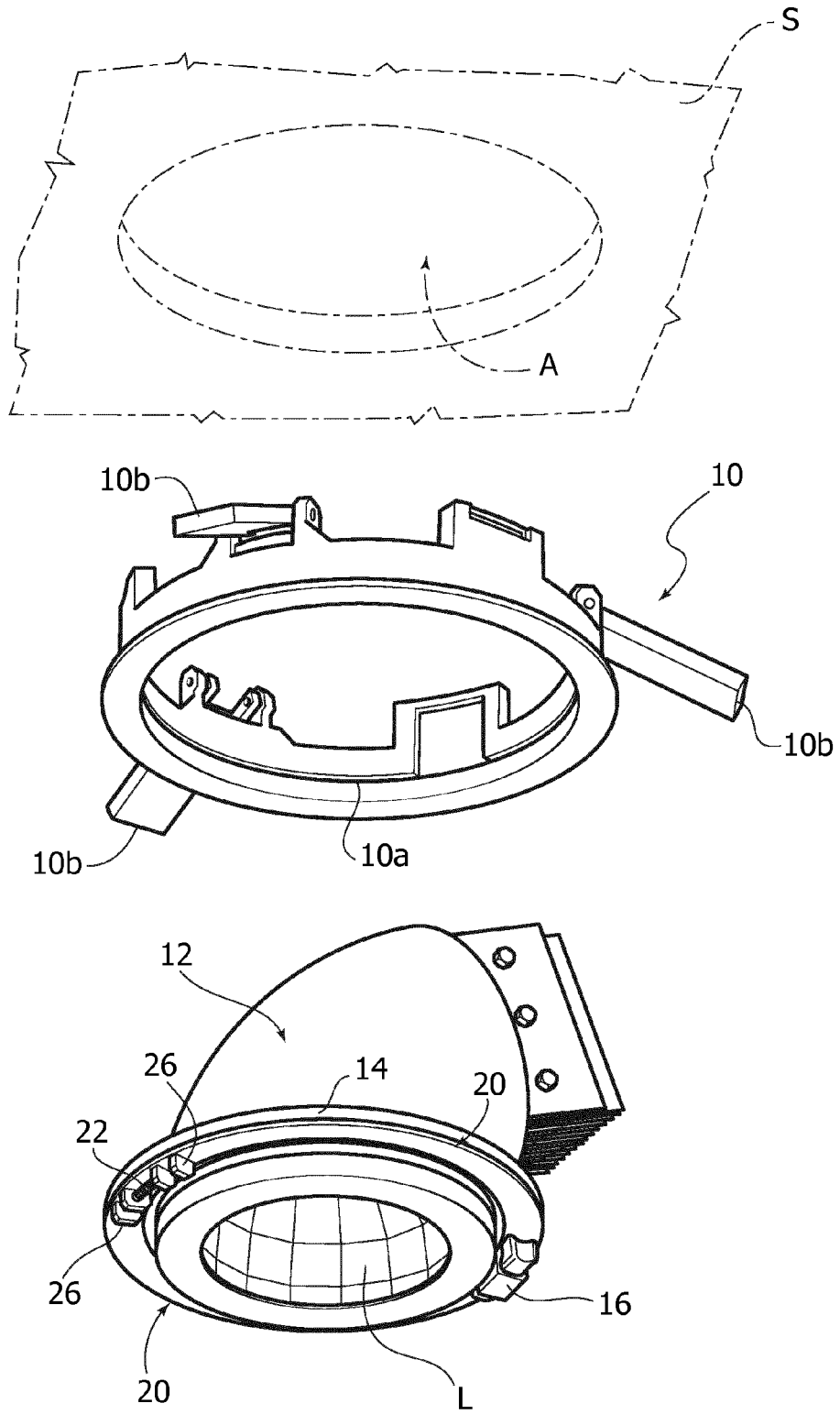

FIG. 2

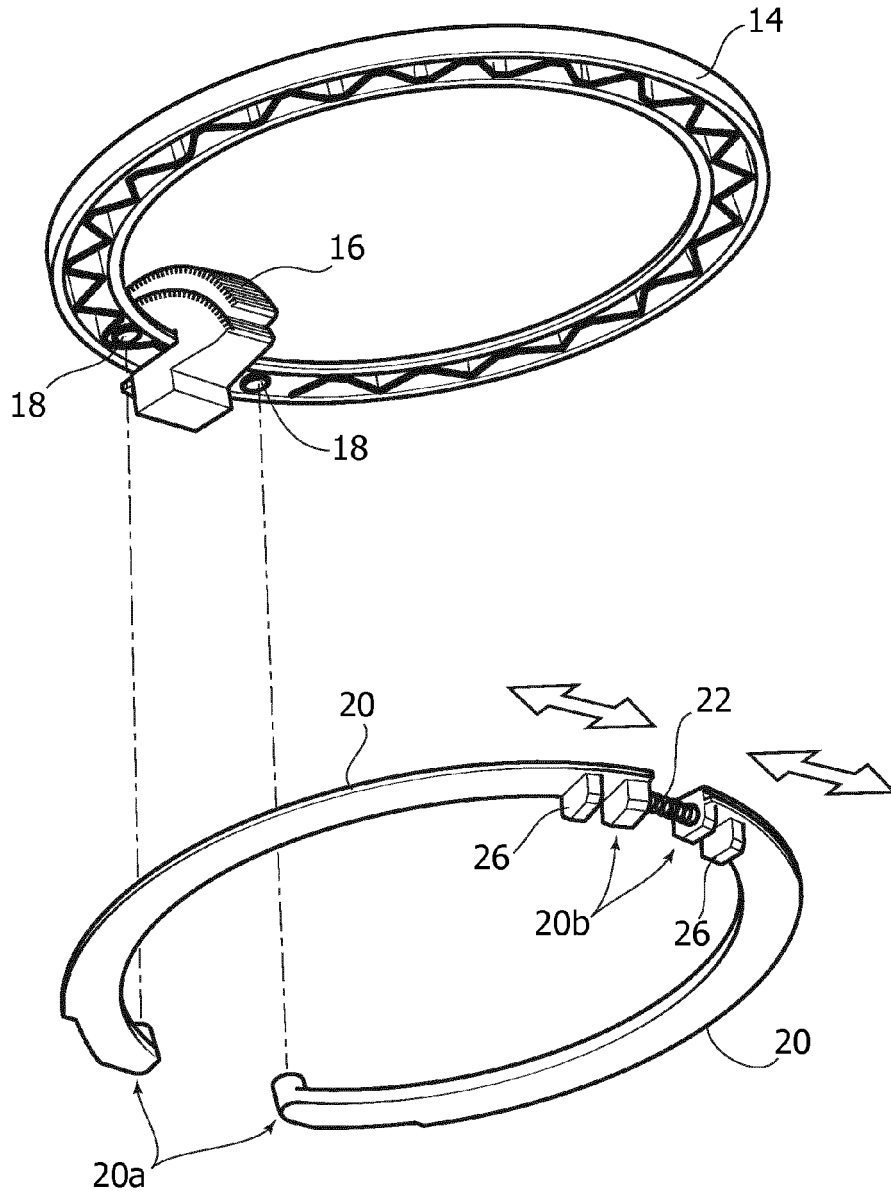

FIG. 3

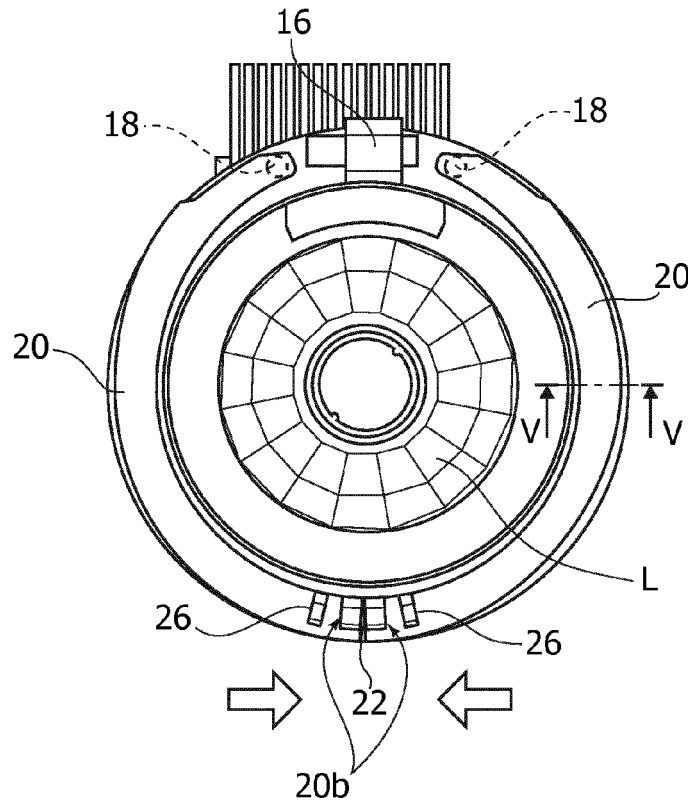

FIG. 4

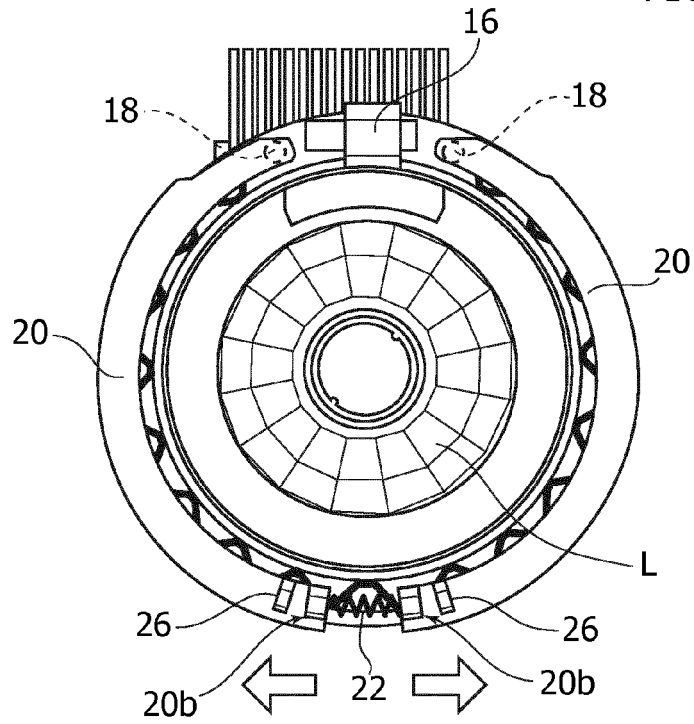

FIG. 5

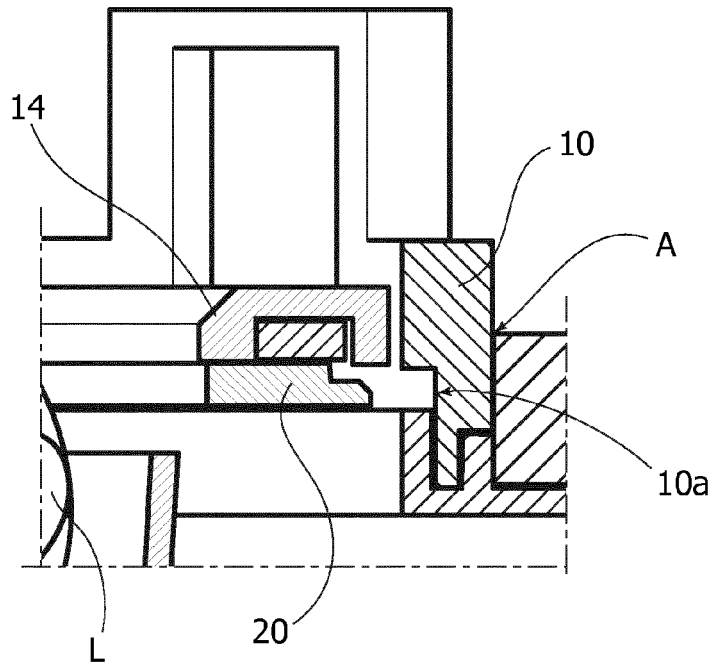
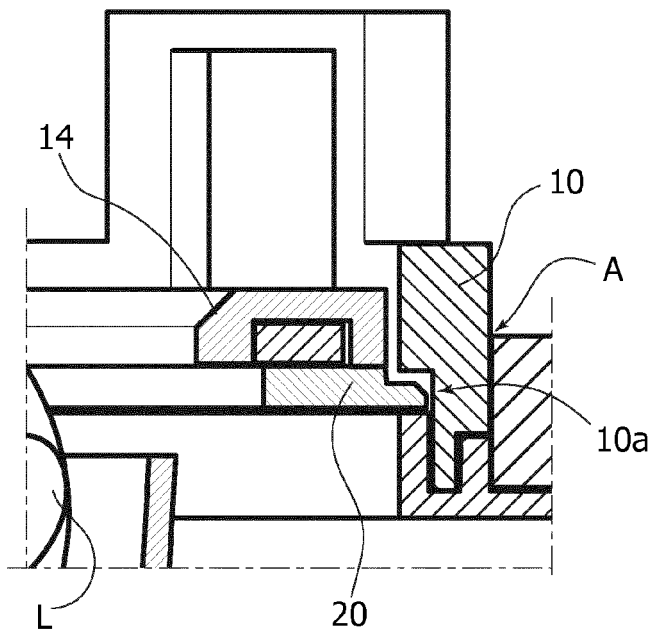

FIG. 6





EUROPEAN SEARCH REPORT

Application Number
EP 13 18 1904

DOCUMENTS CONSIDERED TO BE RELEVANT			
Category	Citation of document with indication, where appropriate, of relevant passages	Relevant to claim	CLASSIFICATION OF THE APPLICATION (IPC)
X A	GB 2 450 986 A (MICROLIGHTS LTD [GB]) 14 January 2009 (2009-01-14) * page 8, line 1 - page 16, line 25; figures 2,13,14 * -----	1-3,10 4-9	INV. F21S8/02 F21V17/16
X	DE 93 17 677 U1 (TRIMBORN GERD [DE]) 24 February 1994 (1994-02-24) * page 8, line 5 - page 12, line 16; figures 1-5 * -----	1,2,10	
X	WO 2008/051957 A2 (LED LIGHTING FIXTURES INC [US]; TROTT GARY DAVID [US]; PICKARD PAUL KE) 2 May 2008 (2008-05-02) * page 12, line 10 - page 38, line 2; figures 1-15 * -----	1	
			TECHNICAL FIELDS SEARCHED (IPC)
			F21S F21V
The present search report has been drawn up for all claims			
Place of search Munich		Date of completion of the search 17 December 2013	Examiner Arboreanu, Antoniu
CATEGORY OF CITED DOCUMENTS		T : theory or principle underlying the invention E : earlier patent document, but published on, or after the filing date D : document cited in the application L : document cited for other reasons & : member of the same patent family, corresponding document	
X : particularly relevant if taken alone Y : particularly relevant if combined with another document of the same category A : technological background O : non-written disclosure P : intermediate document			

1
EPO FORM 1503 03.82 (P/M/C01)

ANNEX TO THE EUROPEAN SEARCH REPORT
ON EUROPEAN PATENT APPLICATION NO.

EP 13 18 1904

This annex lists the patent family members relating to the patent documents cited in the above-mentioned European search report.
The members are as contained in the European Patent Office EDP file on
The European Patent Office is in no way liable for these particulars which are merely given for the purpose of information.

17-12-2013

Patent document cited in search report		Publication date	Patent family member(s)	Publication date
GB 2450986	A	14-01-2009	NONE	

DE 9317677	U1	24-02-1994	NONE	

WO 2008051957	A2	02-05-2008	CA 2666343 A1	02-05-2008
			CN 101595342 A	02-12-2009
			CN 102937275 A	20-02-2013
			TW 200849660 A	16-12-2008
			US 2008106907 A1	08-05-2008
			US 2011069499 A1	24-03-2011
			US 2012195033 A1	02-08-2012
			US 2013016516 A1	17-01-2013
			WO 2008051957 A2	02-05-2008
