

(19)



(11)

EP 2 708 266 A1

(12)

EUROPEAN PATENT APPLICATION

(43) Date of publication:

19.03.2014 Bulletin 2014/12

(51) Int Cl.:

A63B 21/062 (2006.01) **A63B 23/04** (2006.01)
A63B 21/00 (2006.01) **A63B 71/00** (2006.01)
A63B 23/035 (2006.01) **A63B 24/00** (2006.01)

(21) Application number: **12425152.1**

(22) Date of filing: **14.09.2012**

(84) Designated Contracting States:

AL AT BE BG CH CY CZ DE DK EE ES FI FR GB GR HR HU IE IS IT LI LT LU LV MC MK MT NL NO PL PT RO RS SE SI SK SM TR

Designated Extension States:

BA ME

- **Guadagno, Flavio**
82010 Moiano (BN) (IT)
- **Iuliano, Fiore**
Campoli del Monte Taburno (BN) (IT)

(74) Representative: **Sarpi, Maurizio et al**
Studio Ferrario S.r.l.
Via Collina, 36
00187 Roma (IT)

(71) Applicant: **Eccentrica SRL**
41049 Sassuolo (MO) (IT)

(72) Inventors:

- **Guadagno, Giuseppe**
82010 Moiano (BN) (IT)

(54) **Apparatus for eccentric stimulation of the hamstrings**

(57) The present invention regards a machine (1) for the activity of muscle exercise and/or rehabilitation, in particular for eccentric stimulation of the hamstrings.

Said machine (1), which is of the type comprising:

- first means designed to receive the athlete who is to perform physical exercise; and
- second means designed to apply the load on the limb

of the athlete, said load being due to the descent by gravity of one or more weights (12);

is characterized in that said second means (4) designed to apply the load on the lower limb of the athlete, are positioned on one side of said machine (1), except for a bar (16) and a pad (17), so as to be set, for reasons of safety, at an adequate distance from the body of said athlete.

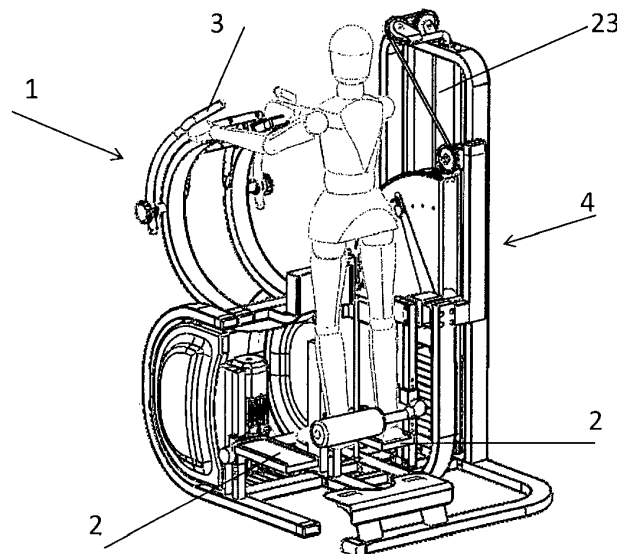

Fig. 1

EP 2 708 266 A1

Description

[0001] The present invention relates to a machine for the activity of muscle exercise and/or rehabilitation, in particular for eccentric stimulation of the hamstrings (i.e. the flexor muscles of the thigh).

[0002] In the management of training of athletes, it is necessary to take into account the fact that athletes are frequently subjected to stresses of various nature, chiefly to loading of the musculoskeletal apparatus, which can damage the structures of said apparatus, forcing the athlete to interrupt the sporting activity for a given period of time, which varies according to the amount of damage.

[0003] From the data recorded, it appears evident that the muscles most subject to injuries, both in soccer and in rugby or American football, are the hamstrings. This seems to confirm that the greater the capacity of the agonist muscles to accelerate, the greater the stress that must be sustained by the muscles that control and brake said acceleration.

[0004] The foregoing is true above all during fast extension of the knee, where there is a considerable demand on the flexor muscles to provide dynamic stabilization of the joint during said active extension of the knee.

[0005] Even though there are currently known many machines and various apparatuses designed for exercising and reinforcing, with "natural movements", one or more muscles of the body, a common problem is represented by the fact that none of them is specifically designed to eliminate the so-called positive or concentric phase of the effort, enabling the athlete to exercise specifically the muscles that intervene only in the negative or eccentric phase, which, given what has been said above, are frequently poorly exercised and consequently are the source of frequent injuries.

[0006] The patent No. IT 1333435, filed in the name of the present applicant, describes an apparatus that is able to exercise specifically, and in a natural way, the hamstrings in order to strengthen them to achieve a degree of strength corresponding to that of the extensor muscles.

[0007] This has been achieved by a machine comprising means designed to lift a load and means designed to apply it to the limb of the athlete only in the phase where said load drops by gravity, i.e., only for the eccentric phase.

[0008] Said apparatus presents, however, a drawback, due to the fact that the weights necessary for loading the muscles, which are considerable, are located in the immediate vicinity of the subject who uses the machine. There is thus possible interference between the moving weights and the body of the user, which entail the possibility of more or less serious injuries.

[0009] The present invention overcomes this drawback by proposing a machine for eccentric stimulation of the hamstrings as specified in Claim 1. Said machine is of the type comprising means designed to receive the athlete who is to perform physical exercise and means designed to apply the load on the lower limb of the athlete,

said load being due to the descent by gravity of one or more weights, and is **characterized in that** said means, designed to apply the load on the lower limb of the athlete, are positioned on one side of said machine so as to be adequately set, for reasons of safety, at a distance from the body of the athlete himself.

[0010] The machine according to the invention basically comprises a system that oscillates, between two extreme positions, about an axis *y*, which is horizontal and transverse with respect to the machine itself, said oscillating system comprising a shaft, mounted on the frame of said machine, free to turn about said axis *y*, mounted at the end of which is a pulley, on one side, and an arm, on the other.

[0011] Said pulley is made to turn by an electric motor, the pulley causing lifting of said weights via a cable and one or more idler pulleys. When the pulley is released, the weights will set it in rotation in the opposite direction, thus also causing rotation of the oscillating arm, which, via appropriate means, will apply on the distal part of the lower limb of the athlete the load necessary to exercise the hamstrings.

[0012] Since the moving mechanical members (weights, pulleys, cables) are located at the side of the machine, at an adequate distance from the athlete, the chances of interference of the body of the athlete with the moving mechanical members are markedly reduced, thus minimizing the risk of injury, also considering that the mechanical members themselves, thanks to their arrangement, can be conveniently shielded by purposely provided guards.

[0013] The invention will now be described, purely by way of illustrative and non-limiting example, according to a preferred embodiment thereof and with reference to the attached figures, in which:

Figure 1 shows a machine according to the invention; Figures 2a and 2b show the means for applying the load to the body of the athlete and, hence, for eccentric stimulation of the hamstrings;

Figure 3 is an exploded view of an oscillating system for applying the load to the body of the athlete.

[0014] With reference to Figure 1, designated by 1 is a machine according to the invention. Said machine 1 comprises means, constituted by a pair of foot plates 2 and a handlebar 3, designed to receive the athlete who is to perform physical exercise, and means 4, for applying the load to the body of the athlete and, hence, for eccentric stimulation of the hamstrings.

[0015] In Figure 1, the athlete rests his right foot on the right foot plate 2 and holds himself in equilibrium by gripping the handlebar 3, the athlete's left leg being ready to bend to counter the thrust that is applied thereon via said means 4.

[0016] Figures 2a and 2b show, separately from the rest of the machine 1, said means 4 for eccentric muscular stimulation and the foot plates 2, with the corre-

sponding height-adjustment means 5.

[0017] The means 4 for applying the load comprise a system 6, more clearly visible in the exploded view of Figure 3, which oscillates, about an axis y, which is horizontal and transverse with respect to the machine 1, between two extreme positions. Illustrated purely by way of example in Figures 2a and 2b are two possible positions of the oscillating system 6, which can be chosen by the athlete for carrying out the exercise, thus defining the working angle.

[0018] Said oscillating system 6 comprises a shaft 7, which is mounted on the frame of the machine 1 and free to turn about said axis y. Mounted at the end of said shaft 7 is a pulley 8, on one side, and an arm 9, on the other, there being provided an electric motor 10, which, via a belt 11, turns said pulley 8, causing lifting of one or more weights 12 through a cable 13 and one or more idler pulleys 14, 14a, 15.

[0019] Moreover provided is a bar 16, mounted on said oscillating arm 9, applied at the end of which is a pad 17, there being provided regulating means 18 for appropriately positioning said bar 16 with respect to said oscillating arm 9.

[0020] To apply the load correctly on the hamstrings, it is necessary for the axis of rotation of the knee to coincide with said axis y about which said oscillating assembly 6 turns. The position in height of the foot plates 2 will hence be adjusted so as to bring the axis of rotation of the knee to coincide with the axis y. Then, by acting on the regulating means 18, the position of the bar 16 will be adjusted with respect to the oscillating arm 9 in such a way that the pad 17 will press on the distal part of the lower limb of the athlete.

[0021] After adjusting the position of the foot plates 2 and of the bar 16 according to what has been described above, the athlete climbs onto the foot plates 2, and stabilizes his position by gripping the handlebars 3. Then, the athlete, after defining the working angle as will be described in what follows, activates the machine 1, which will apply the load on the hamstrings according to the following steps:

- the electric motor 10, via the belt 11, acts on the pulley 8 causing it to turn, from the position of Figure 2a to the position of Figure 2b, lifting, via the cable 13 and the idler pulleys 14, 14a, 15, the weights 12, thus bringing the oscillating arm 9 and hence the bar 16 into the raised position;
- the athlete bends one leg and presses with the distal part of the lower limb against the pad 17 of the bar 16;
- the pulley 8 is released and the weights 12, via the cable 13 and the idler pulleys 14, 15, cause the pulley 8 to turn in the opposite direction so that the oscillating arm 9 turns downwards, said movement being countered by the muscular reaction of the athlete.

[0022] To extend the sphere of application of the machine 1 and render use thereof more comfortable, there

are provided means for adjusting the amplitude of rotation of the pulley 8, i.e., for setting the working angle, and means 21 for engagement-release of said pulley 8, when the action of the electric motor 10 has ceased. Said means for adjusting the amplitude of rotation of the pulley 8 comprise a pawl 19, designed to fit in a plurality of holes 20 made on the side of said pulley 8, said pawl 19 being rendered substantially fixed with respect to said pulley 8 by appropriate elastic means. Limitation of the oscillation of the pulley 8 is thus obtained owing to the fact that the lever 19a bears upon said engagement-release means 21, which are designed to block and release said pulley 8. Said lever 19a can advantageously be mounted at the end of a rod 22, which selects the working angle and is free to turn about the axis y. In practice, the athlete adjusts the amplitude of rotation of the pulley 8, and hence of the arm 9, by inserting the pawl 19 in the hole 20 that he deems most appropriate; then he activates the electric motor 10, which will cause rotation of the pulley 8 until the lever 19a comes to bear upon said engagement-release means 21. For proper operation of the electric motor 10 it is preferable to use a micro-switch (not represented), set in a position corresponding to said engagement-release means 21, to interrupt electric supply to the motor 10 when the pulley 8 has reached end-of-travel.

[0023] When the athlete is ready to exert muscular effort, he acts on said engagement-release means 21, releasing the pulley 8, which will thus cause rotation downwards of the oscillating arm 9 and, hence, application of the load on the hamstrings of the athlete.

[0024] According to a preferred embodiment of the invention, the pawl 19 materially exerts the action of blocking the rod 22 that selects the working angle by entering the holes 20, whilst a bracket 19a enables anchorage of the rod 22, and hence of the entire oscillating assembly 6, to the engagement-release device 21.

[0025] According to another preferred embodiment of the invention, the machine is provided with means (not represented) that are able to block operation of the machine itself in the case where the hands of the athlete are not in the proper positions, said means comprising push-buttons, positioned on the handlebar and connected to means for blocking the mechanisms. In practice, in the case where the athlete were to remove his hands from the handlebar, he would no longer act on the push-buttons, and the machine would block to prevent any possible injuries.

[0026] As may be seen from Figures 1 and 2, the weights 12 and the pulley 8 are positioned on one side of the machine 1. By acting on the length of the shaft 7, which connects the pulley 8 to the oscillating arm 9, said weights 12 and said pulley 8 can be shifted by the athlete as much as he wishes so as to eliminate virtually any interference of the weights and of the other mechanical members with his body, thus minimizing the possibility of injury. In order to increase further the safety of the machine, appropriate guards 23 may be provided, as illustrated in Figure 1.

[0027] With the arrangement described, the only moving elements that are in the proximity of the athlete are the oscillating arm 9 and the bar 16, the degree of danger of which is far less than that of the other mechanical members, it being possible to reduce further said danger by making the bar 16 of a convenient length.

[0028] The invention has been described, by way of illustrative and non-limiting example, according to a preferred embodiment. The person skilled in the sector may devise other embodiments, all of which fall within the sphere of protection of the annexed claims.

Claims

1. A machine (1) for eccentric stimulation of the hamstrings, of the type comprising:

- first means designed to receive the athlete who is to perform physical exercise; and
- second means designed to apply the load on the limb of the athlete, said load being due to the descent by gravity of one or more weights (12);
said machine being **characterized in that** said second means (4) designed to apply the load on the lower limb of the athlete are positioned on one side of said machine (1), except for a bar (16) and a pad (17), so as to be set, for reasons of safety, at an adequate distance from the body of said athlete.

2. The machine (1) according to Claim 1, **characterized in that** said first means, designed to receive the athlete who is to perform physical exercise, comprise a pair of foot plates (2) and a pair of handles (3).

3. The machine (1) according to Claim 2, **characterized in that** the position of said foot plates (2) is height-adjustable.

4. The machine (1) according to Claim 1, **characterized in that** said second means (4), designed to apply the load on the lower limb of the athlete, said load being due to the descent by gravity of one or more weights (12), comprise third means, designed to lift said one or more weights (12), and fourth means, designed to convert the descent by gravity of said one or more weights (12), into a load applied on the lower limb of the athlete.

5. The machine (1) according to Claim 4, **characterized in that** said third means, designed to lift said one or more weights (12), comprise an electric motor (10), which, via a belt (11), turns a pulley (8), said pulley (8) causing lifting of said one or more weights (12).

6. The machine (1) according to Claim 5, **characterized in that** said pulley (8), driven by said electric motor (10) via said belt (11), causes lifting of said one or more weights (12), via a cable (13) and one or more idler pulleys (14, 14a, 15).

7. The machine (1) according to Claim 4, **characterized in that** said fourth means, designed to convert the descent by gravity of said one or more weights (12) into a load applied on the lower limb of the athlete, comprise a system (6), which oscillates between two extreme positions, about a axis y, horizontal and transverse with respect to the machine (1), said oscillating system (6) comprising a shaft (7), which is mounted, on the frame of said machine (1), so that it is free to turn about said axis y, there being mounted at one end of said shaft (7) said pulley (8) and at the other end an arm (9).

8. The machine (1) according to Claim 7, **characterized in that** it further envisages a bar (16), mounted on said oscillating arm (9), applied at the end of which is a pad (17), there being provided regulating means (18) for appropriately positioning said bar (16) with respect to said oscillating arm (9).

9. The machine (1) according to Claim 7, **characterized in that** it envisages means (21) for engagement-release of said pulley (8) when the action of the electric motor (10) has ceased, said engagement-release means (21) being designed to engage and release a pawl (19), rendered fixed with respect to said pulley (8), or a bracket (19a) set in the immediate vicinity of said pawl (19).

10. The machine (1) according to Claims 7 and 9, **characterized in that** it envisages means for regulating the amplitude of rotation of the pulley (8), said regulating means comprising said pawl (19), designed to enter said plurality of holes (20) made on the side of said pulley (8), or said bracket (19a), set in the immediate vicinity of said pawl (19), said pawl (19), or said bracket (19a), engaging said engagement-release means (21).

11. The machine (1) according to Claims 7, 9, and 10, **characterized in that** said pawl (19) is mounted at the end of a rod (22) that is free to turn about said axis y.

12. The machine (1) according to Claims 7, 9, 10 and 11, **characterized in that** said bracket (19a) is mounted at the end of said rod (22), free to turn about said axis y.

13. The machine (1) according to at least one of Claims 1 to 12, **characterized in that** it envisages means designed to block the mechanisms of said machine

(1) in the case where the hands of the athlete are not in the proper positions, said means comprising pushbuttons, positioned on the handlebar (3) and connected to means for blocking the mechanisms of said machine (1) in such a way that, in the case where the athlete were to remove his hands from the handlebar, he would no longer act on said pushbuttons, and the machine would block.

5

14. The machine (1) according to at least one of Claims 1 to 13, **characterized in that** it envisages guards (23) for protection from the moving mechanical members.

10

15

20

25

30

35

40

45

50

55

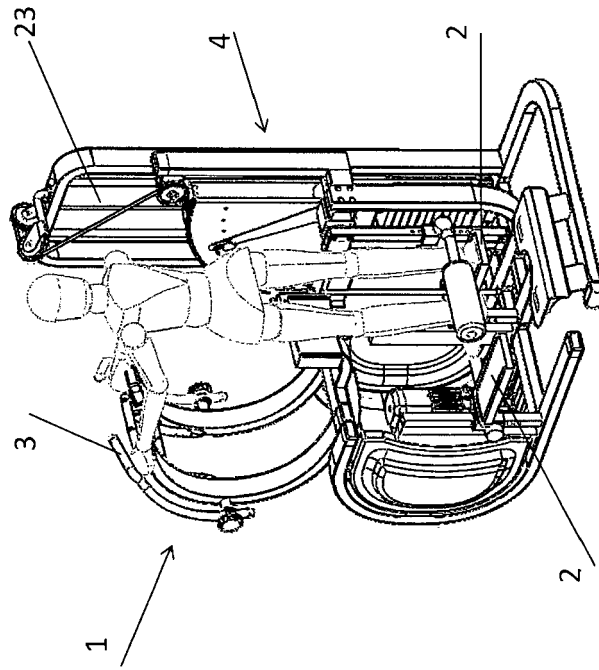

Fig. 1

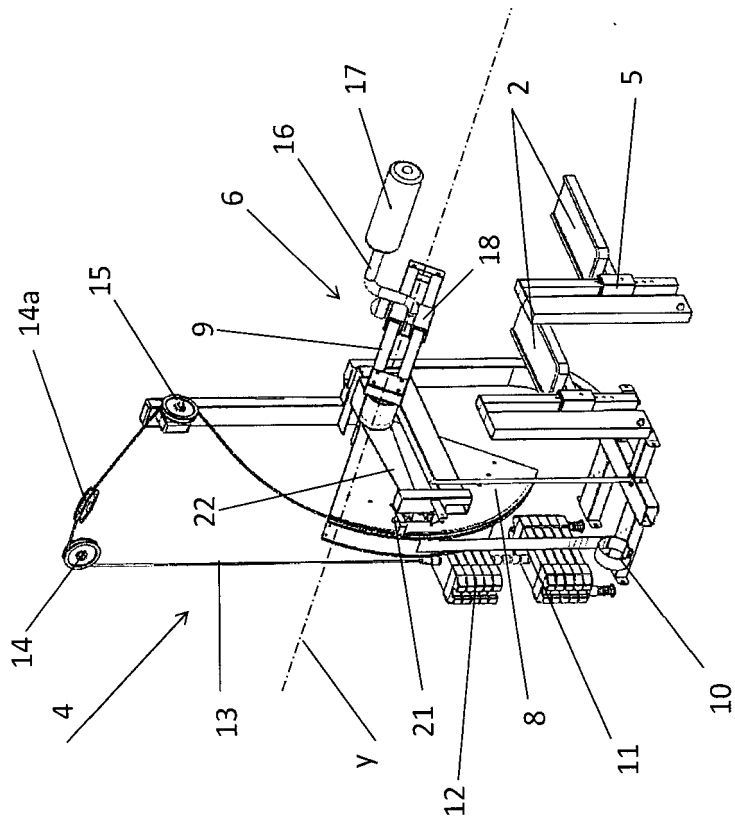

Fig. 2b

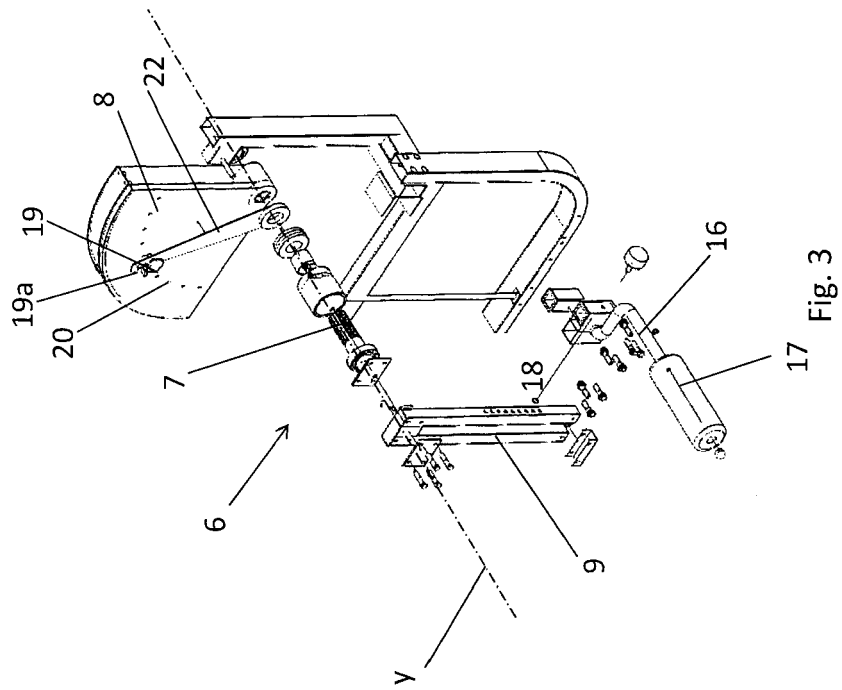

Fig. 3



EUROPEAN SEARCH REPORT

Application Number
EP 12 42 5152

DOCUMENTS CONSIDERED TO BE RELEVANT			
Category	Citation of document with indication, where appropriate, of relevant passages	Relevant to claim	CLASSIFICATION OF THE APPLICATION (IPC)
X	US 6 666 801 B1 (MICHALOW ALEX [US]) 23 December 2003 (2003-12-23)	1-3,13, 14	INV. A63B21/062
Y	* paragraph [0099] * * paragraph [0113] - paragraph [0116] * * paragraph [0133]; figures *	4-12	A63B23/04
Y	US 5 435 798 A (HABING THEODORE G [US] ET AL) 25 July 1995 (1995-07-25) * column 2, line 15 - line 40; figures *	4-12	ADD. A63B21/00 A63B71/00 A63B23/035 A63B24/00
Y	US 2008/176722 A1 (STEFFEE CLAY [US]) 24 July 2008 (2008-07-24) * the whole document *	7-12	
X	US 2004/209745 A1 (RINEY DENNIS P [US] ET AL) 21 October 2004 (2004-10-21) * the whole document *	1-3	
			TECHNICAL FIELDS SEARCHED (IPC)
			A63B
The present search report has been drawn up for all claims			
Place of search		Date of completion of the search	Examiner
Munich		18 March 2013	Squeri, Michele
CATEGORY OF CITED DOCUMENTS			
X : particularly relevant if taken alone Y : particularly relevant if combined with another document of the same category A : technological background O : non-written disclosure P : intermediate document		T : theory or principle underlying the invention E : earlier patent document, but published on, or after the filing date D : document cited in the application L : document cited for other reasons & : member of the same patent family, corresponding document	

2
EPO FORM 1503 03.02 (F04C01)

**ANNEX TO THE EUROPEAN SEARCH REPORT
ON EUROPEAN PATENT APPLICATION NO.**

EP 12 42 5152

This annex lists the patent family members relating to the patent documents cited in the above-mentioned European search report.
The members are as contained in the European Patent Office EDP file on
The European Patent Office is in no way liable for these particulars which are merely given for the purpose of information.

18-03-2013

Patent document cited in search report		Publication date	Patent family member(s)	Publication date
US 6666801	B1	23-12-2003	NONE	

US 5435798	A	25-07-1995	NONE	

US 2008176722	A1	24-07-2008	NONE	

US 2004209745	A1	21-10-2004	NONE	

EPO FORM P0459

For more details about this annex : see Official Journal of the European Patent Office, No. 12/82

REFERENCES CITED IN THE DESCRIPTION

This list of references cited by the applicant is for the reader's convenience only. It does not form part of the European patent document. Even though great care has been taken in compiling the references, errors or omissions cannot be excluded and the EPO disclaims all liability in this regard.

Patent documents cited in the description

- IT 1333435 [0006]