

(19)



(11)

**EP 2 719 821 A1**

(12)

**EUROPEAN PATENT APPLICATION**

(43) Date of publication:  
**16.04.2014 Bulletin 2014/16**

(51) Int Cl.:  
**D06F 58/22 (2006.01)**  
**D06F 58/20 (2006.01)**  
**D06F 58/24 (2006.01)**

(21) Application number: **12007131.1**

(22) Date of filing: **15.10.2012**

(84) Designated Contracting States:  
**AL AT BE BG CH CY CZ DE DK EE ES FI FR GB GR HR HU IE IS IT LI LT LU LV MC MK MT NL NO PL PT RO RS SE SI SK SM TR**  
Designated Extension States:  
**BA ME**

- **Reid, Nicola**  
**33080 Porcia (PN) (IT)**
- **Cavarretta, Francesco**  
**33080 Porcia (PN) (IT)**
- **Rossi, Giuseppe**  
**33080 Porcia (PN) (IT)**

(71) Applicant: **Electrolux Home Products Corporation N.V.**  
**1130 Brussel (BE)**

(74) Representative: **Nardoni, Andrea et al**  
**Electrolux Italia S.p.A.**  
**Corso Lino Zanussi, 30**  
**33080 Porcia (PN) (IT)**

(72) Inventors:  
• **Bison, Alberto**  
**33080 Porcia (PN) (IT)**

(54) **Laundry treatment apparatus**

(57) The invention relates to laundry treatment apparatus (2) comprising a laundry treatment chamber (4) for treating laundry using process air, a process air circuit for circulating the process air, a heat exchanger (38) arranged in the process air circuit for cooling the process air, a conveying means (44, 46) connected to a liquid supply source adapted to convey liquid to a component of the treatment apparatus for cleaning at least a portion of the component's surface by removing fluff therefrom, and a liquid collector (32) assigned to the component and adapted to collect liquid from same, the laundry treatment apparatus further comprises a first filter device (10a) arranged in section (24) of the process air circuit downstream the laundry treatment chamber (4) and a feeding means (40, 42) adapted to supply liquid from said liquid collector (32) to the first filter device (10a), wherein the first filter device (10a) is adapted to filter fluff from the supplied liquid.

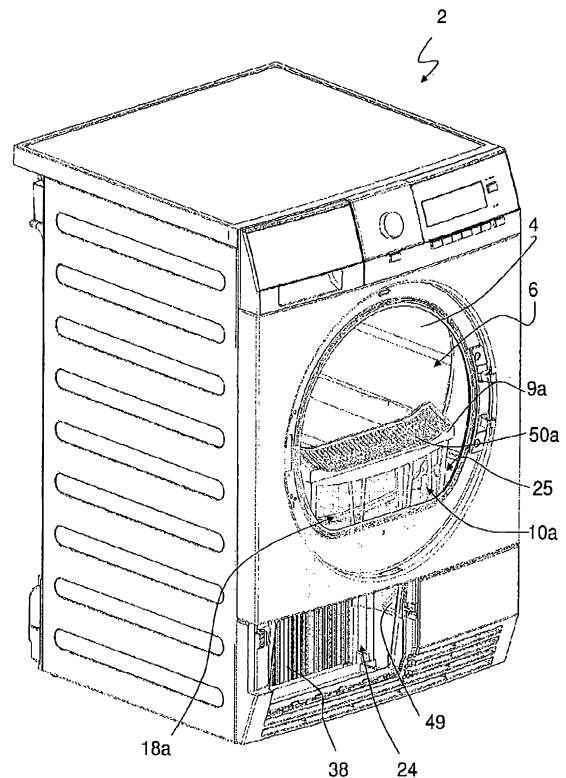

Fig. 2a

**EP 2 719 821 A1**

## Description

**[0001]** The invention relates to a laundry treatment apparatus, in particular dryer, heat pump tumble dryer or washing machine having a dryer function, comprising a liquid filter device.

**[0002]** DE 10 2008 054 832 A1 discloses a laundry dryer comprising a device for cleaning a heat exchanger or a process air filter arranged in a process air circuit of the dryer, wherein the heat exchanger is adapted to cool process air. Condensate generated at the heat exchanger during a drying operation of the dryer is collected in a first container from where it is fed to a liquid filter device to filter fluff from the collected liquid. Filtered liquid is collected in a second container from where it is conveyed to the heat exchanger to clean the heat exchanger surface, i.e. to wash off the fluff. Alternatively or additionally filtered liquid is conveyed to the process air filter for washing off the fluff collected thereon. Liquid with the washed off fluff from the process air filter is also fed to the liquid filter device, wherein subsequently the filtered liquid is also collected in the second container.

**[0003]** It is an object of the invention to provide a laundry treatment apparatus having a liquid filter device providing an improved machine integration.

**[0004]** The invention is defined in claim 1. Particular embodiments are set out in the dependent claims.

**[0005]** According to claim 1 a laundry treatment apparatus is provided, in particular a dryer, a heat pump tumble dryer, a condensate dryer or a washing machine having a dryer function, which comprises a laundry treatment chamber for treating laundry using process air, a process air circuit for circulating the process air and a heat exchanger arranged in the process air circuit for cooling the process air. When drying laundry with the treatment apparatus, fluff is generated which is carried from the treatment chamber and transported along the process air channel. The fluff may deposit while the process air is conveyed in the process air channel at a component of the treatment apparatus arranged along the path of the process air through the process air channel. For example, if the component is the heat exchanger which cools the process air, condensate is generated at the heat exchanger surface such that the fluff carried by the process air may deposit on the wet heat exchanger surface. Due to fluff deposition the heat exchanger performance may deteriorate over time as fluff accumulates on its surface. This correspondingly may apply to any other of the components arranged along the process air path in the process air channel. To prevent this a conveying mean is provided which is connected to a liquid supply source and is adapted to convey liquid to the component for cleaning or washing at least a portion of the component surface with the conveyed liquid.

**[0006]** A liquid supply source may be for example tap water from a water system, condensate from the heat exchanger collected in a container, and additionally or alternatively filtered water from a liquid filter as described

in more detail below. For example the conveying means may comprise an outlet directed to the component surface to be cleaned and/or a pump which is adapted to pump liquid through the outlet to the component. Alternatively cleaning liquid may be driven by gravity through the outlet to the component, e.g. a liquid supply source providing the liquid may be arranged at a higher location than the outlet and/or the component.

**[0007]** The conveying means may be adapted to clean a front surface or front portion of the component which faces the process air channel and at which fluff from the process air collects or accumulates. By means of the conveying means fluff is washed off from the component surface, which improves the performance of the treatment apparatus.

**[0008]** A liquid collector is assigned to the component and is adapted to collect liquid from the component, for example condensate generated at the component and liquid conveyed to the component for cleaning as described above. In other words the liquid collector, which is assigned to the component, is adapted to collect liquid that may carry fluff or lint (which is thus dirty or contaminated liquid).

**[0009]** A first filter device is provided to filter the collected liquid. The filtered liquid may be (re)used for cleaning the component or may be collected e.g. for ironing. The first filter device is arranged in a process air section of the process air circuit downstream the laundry treatment chamber, i.e. process air may pass through the first filter device or may bypass or flow around the first filter device which is arranged in the process air path.

**[0010]** A feeding means is adapted to supply liquid from the liquid collector to the first filter device, wherein the first filter device is adapted to filter fluff from the supplied liquid, i.e. the first filter device is a liquid filter which is arranged in the process air circuit. By arranging the first filter device in the process air circuit, liquid leakage from the first filter device is not a problem, in particular when the filtered liquid is the condensate collected from the component (which may be the first heat exchanger). In such an arrangement leaking liquid flows within the process air circuit (comprising a condensate collector) towards the component where it condensates and/or collects as liquid. Thus system integration and security of arranging the first filter device is improved.

**[0011]** Most preferably the component of the treatment apparatus which surface is to be cleaned from fluff is the heat exchanger, e.g. the first heat exchanger of a heat pump system (evaporator or gas heater) to which the process air is guided by the process air channel after being exhausted from the laundry treatment chamber. Alternatively the component may be any other component of the treatment apparatus or of a heat pump system of the apparatus which is arranged in the process air channel or has at least a surface in contact with the process air flowing through the process air channel. For example the component is a fluff filter, a heating element, a nozzle for injecting a treatment agent into the process

air channel, or a plate, like a heat exchanging plate, being arranged in the process air channel or being a wall of the process air channel.

**[0012]** In the following generally reference is made to the 'heat exchanger' as an example for the above mentioned 'component' of the treatment apparatus. It is within the scope and meaning that the heat exchanger may be only a reference example for the 'component' and may be replaced by 'component' and any other example for the 'component' which is to be cleaned by the liquid provided by the conveying means.

**[0013]** Preferably the first filter device is arranged in the process air channel or the process air circuit downstream the laundry treatment chamber and upstream heat exchanger (the 'component'). Additionally of alternatively the first filter device is arranged downstream a pocket filter, i.e. a pocket filter is arranged in the process air flow path downstream the treatment chamber and upstream the first filter device.

**[0014]** The type of filter used as or in the first filter device is preferably a mesh filter or any other type of filter adapted to filter fluff out of a liquid flow.

**[0015]** In an embodiment additionally process air may pass through the liquid filter, whereby fluff collected in the first filter device, i.e. collected (wet) fluff from liquid filtering, may be dried by the process air, i.e. after a drying operation of the treatment apparatus a removal of the (dried) fluff from the first filter device is facilitated. Further, by drying the wet fluff collected in the first filter device (upstream the heat exchanger) process air is cooled down before it enters the heat exchanger. Thereby the performance of the heat exchanger is improved, i.e. the process air downstream the treatment chamber is cooled before it passes the heat exchanger, such that more liquid vapor condensates at the heat exchanger, i.e. more liquid is withdrawn from the process air. In this way user handling of the first filter device or liquid filter device is improved.

**[0016]** In an embodiment the treatment apparatus is a heat pump tumble dryer and a second heat exchanger for heating the process air is provided in the process air circuit downstream the above mentioned (first) heat exchanger.

**[0017]** According to an embodiment a second filter device is arranged in the process air circuit downstream the laundry treatment chamber and upstream the heat exchanger, wherein the second filter device is adapted to filter fluff from the process air. In particular the first filter device and the second filter device are arranged at the same mounting location or are arranged adjacent to each other, such that a user has to access only one position or place e.g. for cleaning both filters.

**[0018]** Preferably a filter arrangement (an integrated or combination filter arrangement) is located in the process air circuit downstream the laundry treatment chamber and upstream the heat exchanger, wherein the filter arrangement comprises the first device and the second filter device, i.e. the first and second filter devices are

combined or connected to a single filter arrangement which facilitates the handling of the filter devices. For example, when the filter devices have to be cleaned, both filter devices may be removed together instead of each filter device on its own. In an embodiment the filter arrangement is the pocket filter which is normally used for filtering fluff from the process air exiting the laundry treatment chamber. E.g. the second filter device is the pocket filter having integrated therein the first filter device. The pocket filter may be inserted at an inlet opening to the process air channel where the inlet opening is arranged at or close to the loading opening for loading laundry into the laundry treatment chamber.

**[0019]** According to an embodiment the first filter device, the second filter device and/or the filter arrangement is arranged in or at the process air channel section at a loading opening of the laundry treatment chamber. Thus the filter arrangement or the filter devices are easily accessible for a user for cleaning, for example after opening a laundry door closing the loading opening of the treatment chamber.

**[0020]** Preferably the process air channel section, in which the first filter device, the second filter device and/or the filter arrangement is arranged, is formed in or integrated in a front frame of the apparatus. In comparison to an individual channel element which has to be separately attached to the apparatus or front frame, the above described treatment apparatus comprises less components, i.e. the assembly of the treatment apparatus is facilitated and assembly time is reduced.

**[0021]** According to an embodiment the first and second filter device are combined in a single filter element of the filter arrangement i.e. a combined air/ liquid filter arrangement is provided having an air filter section or portion and a liquid filter section or portion. Such a one-piece filter arrangement is easy to handle, e.g. when it is removed from or inserted into the apparatus e.g. for cleaning. Further the combined air filter/ liquid filter arrangement means less components and less assembly costs. For example the first filter device may be a portion of the second filter device, i.e. a liquid filter section or portion, e.g. a liquid filter mesh, may be integrated in an air filter device or a liquid filter device comprises an air filter portion or section, e.g. an air filter mesh. Preferably the first filter device is further adapted to filter fluff from the process air, i.e. only one filter device is provided to filter fluff from the process air as well as liquid. For example a filter element of the first filter device (e.g. a filter net or mesh) is adapted to filter air as well as liquid.

**[0022]** According to an embodiment the first filter device may have a shielding element adapted to deflect the process air flow such that no process air or only a reduced process air flow is entering or passing the first filter device. In other words the shielding element provides that all of the process air or most of the process air is directed to a second filter device - i.e. an air filter device e.g. as described above - such that it is ensured that fluff is efficiently removed from the process air before the process

air passes the heat exchanger. This is particularly applicable to the above solution of the first and second filter devices arranged close to each other or when being integrated in one filter arrangement or when the first and second filter are implemented in a common filter structure where one portion forms or is assigned to the first and the other portion forms or is assigned to the second filter or vice versa.

**[0023]** Preferably the first filter device, the second filter device and/or the whole filter arrangement is removably arranged in the laundry treatment apparatus. Thus the filter arrangement or the filter devices can be removed from the treatment apparatus for cleaning, i.e. to remove collected fluff from the air filter as well as the liquid filter. For example each of the filter devices is separately removable from the treatment apparatus, such that according to requirements the filter devices may be cleaned separately or independently from each other, e.g. if only the air filter device needs cleaning the liquid filter device may remain inserted in the treatment apparatus.

**[0024]** The filter arrangement or each of the filter devices may be formed as a pocket filter, e.g. comprising two shells or two frames which are pivotally connected to each other by means of a hinge element, such that after removing the filter arrangement or a filter device from the treatment apparatus the two frames may be swung open to remove fluff collected at an inner surface of the filter arrangement or device.

**[0025]** Preferably the first filter device and the second filter device are combined in the filter arrangement and the first filter device is detachable from the filter arrangement or from the second filter device for cleaning i.e. after removing the whole filter arrangement from the treatment apparatus the first filter device (liquid filter device) may be removed from the (remaining) filter arrangement. Thus the filter arrangement may be removed and inserted in one-piece, but the liquid filter device is separately detachable to facilitate cleaning. For example wet or moist fluff collected in the first filter device may be washed off with water, while dry fluff collected in the second filter device may be removed by hand.

**[0026]** According to an embodiment the first filter device comprises a liquid filter element, e.g. a liquid filter mesh or net, arranged at a bottom or lower portion of the filter device, i.e. the liquid filter device comprises a liquid filter element at the location where most or all of the (dirty) liquid fed to the first filter device by the feeding means collects or passes due to gravity, i.e. at the bottom or lower portion of the filter device.

**[0027]** Preferably at least a portion of the first filter device is a portion of the process air filtering section of the second filter device, in other words at least a portion of an air filter device is adapted to filter liquid. For example lateral sides of the second filter device comprise air filter elements, like a process air filter mesh or net, wherein a lower or bottom portion of the second filter device comprises a liquid filter element like a liquid filter mesh. The portion of the area of the process air filtering section of

the second filter device that is used for liquid filtering may be in the range of: 5-10%, 5-20%, 10-20%, 20-30%, 3-8% of the cross-section area where the process air passes the second filter device on the way to the heat exchanger.

**[0028]** According to an embodiment at least a portion of the first filter device comprises an inclined base portion to assist liquid flow towards the liquid collector or towards a filtered liquid container. A separate clean liquid or filtered liquid collector may be provided, i.e. condensate and the rinsing or cleaning liquid (dirty) which contains fluff is collected in one container or tank and filtered liquid is collected in a separate container, i.e. the filtered liquid collector or container is assigned to the first filter device or filter arrangement and is adapted to collect the liquid from the first filter device or filter arrangement.

**[0029]** Preferably the condensate and/or dirty liquid collector and the filtered liquid container are arranged in a base unit of the treatment apparatus. For example the filtered liquid container may be a container arranged below the first filter device or filter arrangement or may comprise a container section and a guiding section, wherein guiding section collects and guides filtered liquid from the first filter device to the filtered liquid container section. In particular the container section may be arranged below the guiding section or may be displaced and/or distant to the filter devices or filter arrangements. Thus the condensate and/or dirty liquid collector and filtered liquid container may be arranged in a space-saving manner in a base unit of the treatment apparatus, e.g. may be formed integrally with the base unit such that assembly is facilitated and assembly time reduced.

**[0030]** According to an embodiment the filtered liquid container is fluidly connected to the first filter device or filter arrangement by means of a drain conduit. Preferably at least a portion of the conduit is arranged below the condensate and/or dirty liquid collector and additionally or alternatively is arranged and passing at a side of the liquid collector, i.e. filtered liquid is conveyed via the conduit to a rear portion of the base unit. For example filtered liquid is conveyed beneath the heat exchanger to a rear filtered liquid container. Alternatively a partition wall is arranged between the conduit and the liquid collector and additionally or alternatively a partition wall is arranged between a container section of filtered liquid container and the condensate and/or dirty liquid collector. 'Conduit' may be understood as the above described conduit section of the filtered liquid container, wherein the above described embodiments provides a compact arrangement of the filtered liquid container in a treatment apparatus.

**[0031]** Preferably the feeding means may comprise a first pump for pumping (dirty) liquid from the condensate and/or dirty liquid collector to the first filter device or an intermediate tank fluidly connected to the first filter, i.e. excess (dirty) liquid from the condensate and/or dirty liquid collector may be pumped to an intermediate tank. When the intermediate tank is removable a user may remove the tank and discharge the collected liquid. The

intermediate tank may be an extractable drawer that is arranged as a drawer, e.g. at an upper region of the laundry treatment apparatus.

**[0032]** The conveying means may comprise a second pump for pumping liquid from the filtered liquid container to the heat exchanger or to an intermediate tank fluidly connected to the heat exchanger e.g. when a liquid level of the filtered liquid container rises above a predetermined maximum level (which may be controlled by the control unit by means of a liquid level sensor) excess filtered liquid of the filtered liquid container may be stored in the intermediate tank. The filtered liquid collected in the intermediate tank may be reused at a later point, e.g. when a water level of the filtered liquid container falls below a minimum level necessary for cleaning the heat exchanger. Additionally or alternatively the intermediate tank is extractable, such that a user may use the collected filtered liquid, e.g. for ironing.

**[0033]** The treatment apparatus may comprise a third pump which is connected to the condensate and/or dirty liquid collector and is controlled by a control unit of the treatment apparatus to drain liquid to an extractable container or to the outside of the treatment apparatus, i.e. when a liquid level of the extractable container reaches a maximum level liquid may be drained from the treatment apparatus.

**[0034]** According to an embodiment the feeding means comprises a two-way valve controlled by a control unit of the laundry treatment apparatus to convey liquid from the condensate and/or dirty liquid collector selectively to an extractable container or to the outside the treatment apparatus, i.e. excess unfiltered (dirty) water may be discharged or removed from the heat exchanger cleaning circuit. For example when an extractable container is full, excess liquid is discharged from treatment apparatus.

**[0035]** Alternatively or additionally the conveying means may comprise a (second) two-way valve controlled by a control unit of the laundry treatment apparatus to convey liquid from the filtered liquid container selectively to an extractable container or outside the treatment apparatus, i.e. excess filtered (clean) water may be discharged or removed from cleaning circuit, e.g. to a filtered water container such that the filtered water may be used by a user, e.g. for ironing.

**[0036]** The feeding means may comprise a liquid conduit having an outlet or a nozzle arranged at the first filter device to spray the liquid to be cleaned in, at or on a liquid filtering element of the first filter device i.e. it is provided that dirty liquid or liquid with fluff reliably reaches the liquid filter portion or section of the first filter element, e.g. it is prevented that wet fluff clogs an air filter section of the first filter element or second filter element.

**[0037]** According to a preferred embodiment a laundry treatment apparatus, in particular a dryer, a condensate or heat pump dryer or a washing machine having a dryer function, is provided which comprises a laundry treatment chamber for treating laundry using process air, a process air circuit for circulating the process air, a heat

exchanger arranged in the process air circuit for cooling the process air, a conveying means adapted to convey liquid to the heat exchanger for cleaning at least a portion of the heat exchanger surface, a liquid collector assigned to the heat exchanger and adapted to collect liquid from the heat exchanger, a feeding means adapted to feed liquid from the liquid collector to a first filter device, wherein the first filter device is adapted to filter fluff from the liquid fed by the feeding means, a filtered liquid container for collecting liquid downstream the first filter device, wherein the conveying means is connected to the filtered liquid container for supplying the liquid to the heat exchanger, and a conduit fluidly connecting the first filter device and the filtered liquid container. The condensate and/or dirty liquid collector and the filtered liquid container are arranged in a base unit of the treatment apparatus, and at least a portion of the conduit is arranged and passing at a side of the liquid collector, and/or at least a portion of the conduit is arranged below the liquid collector, such that filtered liquid is conveyed from the location below the first filter device within the base unit to another location in the base unit, wherein in particular the filtered liquid is guided to a rear region of the base unit and/or from a front region of the base unit. A rear portion of the base unit is defined with respect to a filter device position at a front portion of treatment apparatus, i.e. at a front portion comprising a loading opening to the treatment chamber.

**[0038]** A partition wall may be arranged between conduit and condensate and/or dirty liquid collector and additionally or alternatively a partition wall may be arranged between a container section of the filtered liquid container and the liquid collector

**[0039]** Individual elements or features according to any of the above described embodiments may be combined individually or in any arbitrary combination.

**[0040]** Reference is made in detail to preferred embodiments of the invention, examples of which are illustrated in the accompanying figures, which show:

- 40 Figs. 1a-c a front view and perspective side views of a laundry treatment machine,
- Figs. 2a-b perspective side views of the laundry treatment machine of Figs. 1a-c comprising a filter arrangement according to a first embodiment,
- 45 Figs. 3a-c perspective views of a filter arrangement according to a second embodiment,
- 50 Figs. 4a-d partial perspective side views of the treatment apparatus of Figs. 1a-c comprising a filter arrangement according to a third embodiment,
- 55 Fig. 5 a perspective top view of a base unit of the treatment apparatus of Figs. 1a-c,

- Fig. 6 a top view of a lower shell of the base unit of Fig. 5,
- Figs. 7a-b sectional side views of the lower shell of Fig. 6 along the line A-A,
- Figs. 8a-e perspective views of the lower shell of Fig. 6, and
- Figs. 9 a-c schematic views of three liquid collector and pump arrangements for a laundry treatment machine.

**[0041]** Fig. 1 a shows a front view of a laundry treatment apparatus 2 without a front cover panel and Figs. 1b-c show perspective side views of the treatment apparatus 2, wherein in Fig. 1c a top cover is removed to allow a full view of the elements arranged within the treatment apparatus 2.

**[0042]** The laundry treatment apparatus 2 - in this arrangement a heat pump tumble dryer - comprises a base unit 30 above which a laundry drum 4 is arranged. The treatment apparatus 2 is a front-loading type, i.e. a loading opening 6 for loading laundry into the drum 4 is provided at a front face of the apparatus 2. Depiction of a front cover, side covers and a door for closing the loading opening 6 is omitted in Figs. 1a-c for visibility of internal components.

**[0043]** A heat exchanger 38 for cooling process air downstream the drum 4 is arranged within the base unit 30. A filter arrangement 9a is arranged at the loading opening 6 in a section of the process air channel 24, i.e. downstream the drum 4 and upstream the heat exchanger 38, wherein the filter arrangement 9a is adapted to filter liquid as well as process air. The filter arrangement 9a is formed as a so called pocket filter, i.e. in its operating position the filter arrangement 9a is inserted in a seat 25 which is formed like a pocket in the treatment apparatus 2, in particular which is inserted into the air channel section 24 which in turn is formed in a front frame 8 of the apparatus. Thus the upper portion or the upper end of the filter arrangement 9a is arranged at and fitted in an inlet to the process air channel 24 seen from the loading opening 6. Liquid from a liquid collector 32 is fed by means of a feeding pipe 42 and a first pump 40 under the control of the control unit of the treatment apparatus 2 through a feeding pipe outlet 43 to a liquid filter portion or device 10a of the filter arrangement 9a, which comprises a liquid filter mesh 12a-b-c (Fig. 2b). Filtered liquid from the filter device 10a is collected downstream the filter device 10a in a filtered liquid container 34 (Fig. 6).

**[0044]** A conveying pipe 46 and a second pump 44 (Fig. 5) controlled by a control unit of the the apparatus 2 is provided to convey liquid from the filtered liquid container 34 to the heat exchanger 38 for cleaning at least a portion of the heat exchanger surface, in particular a front portion of the heat exchanger 38 which is passed by process air first. In this embodiment the heat exchang-

er 38 is the evaporator or gas heater of the heat pump system. In other dryer or laundry treatment apparatus embodiment the heat exchanger may be a process air/ambient air heat exchanger. Thus fluff generated during a drying process in the laundry drum 4, which is carried by the process air through the process air channel 24 to the heat exchanger and accumulates at the heat exchanger surface, is washed off the heat exchanger 38. Thereby the heat exchanger performance is maintained along the machine lifetime. The liquid collector 32 (Fig. 7a) is assigned to the heat exchanger 38 to collect liquid downstream the heat exchanger 38, i.e. condensate generated at the heat exchanger 38 and liquid conveyed to the heat exchanger 38 for cleaning. In other words the liquid collector 32 collects 'dirty' liquid, i.e. liquid with fluff or lint washed off the heat exchanger 38, which is fed to the filter arrangement 9a as described above.

**[0045]** The filter arrangement 9a comprises an air filter device or section 18a. Process air from the drum 4 enters the filter arrangement 9a via a grid 50a and passes air filter mesh 20a-d of the air filter device 18a, whereby fluff is filtered from the process air flow. The filtered process air is conveyed through the process air channel section 24 downstream the filter arrangement 9a towards the heat exchanger 38 to be cooled down, i.e. to remove moisture from the process air which condensates at the heat exchanger 38. The liquid condensed at the heat exchanger is collected in the liquid collector 32. In this particular embodiment of a heat pump tumble dryer a second heat exchanger (not shown) is provided downstream the heat exchanger 38 for heating the process air before the heated process air is reintroduced into the laundry drum 4.

**[0046]** Figs. 2a-b show perspective side views of the treatment apparatus 2 of Figs. 1a-c with front and side cover panels, wherein a front portion of the base unit 30 is open to allow a view of the heat exchanger 38 and that part of the channel section 24 of the process air channel which is upstream the heat exchanger 38 and downstream the filter arrangement 9a. A removable or pivotably attached cover may be provided to cover the opening at that part of the channel section to allow inspection and service of the heat exchanger 38 and/or an additional filter arranged immediately in front of the heat exchanger.

**[0047]** In Fig. 2a the filter arrangement 9a is partially withdrawn from its seat 25. In Fig. 2b the filter arrangement 9a is completely removed from the treatment apparatus 9a and two frames 17a-b forming the filter arrangement 9a are swung open by means of a hinge 16a at a lower side of the filter arrangement 9a to facilitate cleaning, i.e. to facilitate removal of collected fluff at an inside surface of the filter arrangement 9a. As described above the filter arrangement 9a comprises a liquid filter device 10a having liquid filter mesh 12a-b arranged in the frames 17a-b and an air filter device 18a having an air filter mesh 20a-d arranged in the frames 17a-b. The liquid filter and air filter device or section of the filter arrangement 9a are formed in one piece, which facilitates

the handling of the filter arrangement 9a during removal, insertion and cleaning.

**[0048]** As shown in Fig. 2b the liquid filter device 10a comprises a side wall 52a which separates the liquid filter device 10a from the air filter device or portion 18a when the filter arrangement 9a is in its seat 25, i.e. in its operating position. The side wall 52a ensures that liquid fed to the liquid filter 10a does not enter the air filter section 18a of the filter arrangement 9a. Further, a filter base 48a of the liquid filter device 10a or portion is inclined to assist liquid flow towards an inlet 35 (Fig. 8a) of the filtered liquid container 34. In an embodiment (also applicable in the embodiments below) a shield element or deflector element may be provided adapted to prevent or at least partially prevent process air to enter the region of the filter arrangement 9a in which the liquid filter 10a is arranged. In this way the air filter 18a is mainly for filtering fluff from the process air and the liquid filter 10a is mainly for filtering fluff from the supplied liquid.

**[0049]** In the depicted embodiment and during a drying operation of the treatment apparatus 2 process air enters the liquid filter device 10a via the grid 50a and exits through the filter mesh 12a-b into the channel section 24. Thus wet or moist fluff filtered from the liquid and collected in the liquid filter device 10a is dried by the warm process air flow downstream the drum 4. This facilitates a removal of the fluff, as dry fluff is easier to remove or handle than wet (and sticky) fluff. Further the process air downstream the drum 4, i.e. upstream the heat exchanger 38, is cooled down by drying the wet fluff, which increases the performance of the heat exchanger 38.

**[0050]** Figs. 3a-c show perspective views of a filter arrangement 9b for a treatment apparatus as described above according to a second embodiment. Unless otherwise mentioned the elements and functions of the filter arrangement 9b correspond to elements and functions of the above described filter arrangement 9a. Fig. 3a shows the filter arrangement 9b in its assembled state, i.e. the state in which the filter arrangement 9b is removed and inserted into the treatment apparatus 2. The assembled filter arrangement 9b is providing a compact handling and comprises a liquid filter device 10b and an air filter device 18b, i.e. the arrangement 9b is easy to handle during removal from and insertion in its seat 25 as described above.

**[0051]** After removing the filter arrangement 9b from its seat 25 (compare Fig. 2a) the liquid filter device 10b is detachable from the remaining filter arrangement, i.e. the air filter device 18b, as shown in Fig. 3b. For example the air filter device 18b and liquid filter device 10b are attached to each other, e.g. by a snap-fit means or by a magnetic holder, which are easy to engage and disengage a plurality of times. Thus the liquid filter device 10b can be cleaned separate to the air filter device 18b. For example the liquid filter device 10b may be washed under running water and fluff may be removed from the air filter device 18b by hand. The air filter device 18b comprises two frames 22a-b which can be swung open as described

above to clean an inner surface thereof.

**[0052]** As shown in Fig. 3c a lid 54a-b is provided at the filter arrangement 9b, i.e. at the air filter device 18b, which prevents that process air flows through the grid 50a to the liquid filter device 10b. In other words the lid 54a-b provides that process air is efficiently guided to the air filter device 18b, i.e. to the air filter section of the filter arrangement 9b. Further, the liquid filter device 9b comprises a side wall 52b as described above to prevent that liquid enters the air filter device 18b.

**[0053]** Figs. 4a-d show partial perspective side views of the treatments apparatus 2 of Figs. 1a-c comprising a filter arrangement according to a third embodiment. Unless otherwise mentioned the elements and functions of the filter arrangement according to the third embodiment correspond to elements and functions of the above described filter arrangements 9a-b. The third filter arrangement 9c comprises a separately removable air filter device 18c and liquid filter device 10c, which are adapted to be inserted in a corresponding air filter seat 28 and liquid filter seat 26. As described above the filter arrangement is arranged at the loading opening 6 of the treatment apparatus 2.

**[0054]** Figs. 4a-b show the removal of the liquid filter device 10c from its seat 26 and the opening of two frames 14a-b of the liquid filter 10c for cleaning. Thus, in contrast to the above described embodiments, the liquid filter device 10c can be separately removed from the treatment apparatus 2 while the air filter device 18c remains inserted in its seat 28. As described above, the liquid filter device 10c comprises a side wall 52c impermeable for liquid to prevent that in the operating position liquid fed to the liquid filter device 10c enters the air filter device 18c. Further the liquid filter device 10c, comprises an inclined base 48b to assist liquid flow towards the filtered liquid container inlet 35. After removing the liquid filter device 10c two frames of the filter device 14a-b which are connected to each other by means of a hinge 16b can be swung open for cleaning.

**[0055]** Figs. 4c-d show the removal of the air filter device 18c from its seat 28 and the opening of two frames 22c-d of the air filter 18c for cleaning. Each of the liquid filter device 10c and the air filter device 18c comprise a grid 50b-c separating the process air channel 24 from the laundry drum 4.

**[0056]** Fig. 5 shows a perspective top view of the base unit 30 of the treatment apparatus with the filter arrangement 9a in its inserted position exemplary representing any of the above described filter arrangements 9a-c. The base unit 30 comprises a lower shell 56 and an upper shell 58, which facilitates the assembly of the base unit 30. The first and second pump 40, 44 are arranged at a rear portion of the base unit 30. The feeding pipe 42 is coupled via a feeding pipe outlet 43 to the liquid filter device 10a, wherein the outlet 43 is adapted to feed or direct liquid towards a liquid filter section of the filter arrangement 9a, i.e. towards a liquid filter mesh 12a-b of the filter device 10a.

**[0057]** Fig. 6 shows a top view of the lower shell 56 of the base unit 30 of Fig. 5. Figs. 7a-b show sectional side views of the lower shell 56 of Fig. 5 along the line A-A. The condensate and/or dirty liquid collector 32 and the filtered liquid container 34 are arranged or formed in the lower shell 56 and are separated from each other by a dividing wall 60. The filtered liquid container 34 is arranged at a rear portion of the lower shell 56 and the condensate and/or dirty liquid collector 32 in front of the filtered liquid container 34 and below the heat exchanger 38. The inlet 35 to the filtered liquid container 34 is arranged at a front of the lower shell 56 or base unit 30 beneath the (inserted) filter arrangement 9a, such that filtered liquid is driven by gravity from the first filter device 10a to the inlet 35. A drain conduit 36 or tunnel connects the inlet 35 at the front of the base unit 30 to the filtered liquid container 34 at the rear of the base unit 30. I.e. the drain conduit 36 runs below the condensate and/or dirty liquid collector 32. Fig. 7b shows the filtered liquid A at its maximum level C, i.e. the filtered liquid level C has (almost) reached the upper end of the dividing wall 60. At a higher liquid level the filtered liquid can flow from container 34 over the upper rim of the dividing wall 60 into the liquid collector 32.

**[0058]** The condensate and/or dirty liquid collector 32 for collecting 'dirty' liquid is essentially arranged below the heat exchanger 38, such that liquid conveyed to the heat exchanger for cleaning and condensate generated at the heat exchanger 38 surface flow down the heat exchanger 38 into the liquid collector 32.

**[0059]** Figs. 8a-d show perspective side views of the lower shell 56 of Fig. 6, Fig. 8a shows the lower shell 56 with the filter arrangement 9a inserted in its seat 25 and Fig. 8b shows the lower shell 56 without the filter arrangement 9a. The seat 25 of the filter arrangement 9a comprises an inclined base 49 which provides that filtered liquid flowing out of the filtered liquid device 10a flows towards the inlet 35.

**[0060]** Fig. 8c shows the lower shell 56 without liquid, Fig. 8d with filtered liquid A in the filtered liquid container 34 and conduit 36 and Fig. 8e shows additionally the unfiltered liquid B in liquid collector 32. The filtered liquid container 34 and the liquid collector 32 extend to a rear portion of the base unit 30 or lower shell 56 where the first and second pump 40, 44 are arranged to pump the filtered liquid A to the heat exchanger 38 and the unfiltered liquid B to the liquid filter device 10a.

**[0061]** Figs. 9a-c show schematic views of three configurations for the laundry treatment apparatus, in particular the above described treatment apparatus, comprising any of the above described liquid filter devices 10a-c or filter arrangements 9a-c. In the following the apostrophe (') at the reference numeral indicates that the configuration is changed as compared to the embodiments described above, but that otherwise all elements and features described above are fully applicable individually or in any arbitrary combination at the below embodiments (which are partially functional representations of the

above embodiments).

**[0062]** Fig. 9a shows a configuration where a single liquid collector or tank, depicted as condensate collector 32', is provided in the lower shell or basement shell 56' to collect (dirty) liquid from the heat exchanger 38. Here only the collector 32' is provided and not collector 34 in contrast to the above described base unit 30 or lower shell 56 which comprises two tanks to separately collect filtered liquid and unfiltered liquid. The configuration of Fig. 9a may be implemented in standard basement units. The unfiltered liquid is pumped from the condensate collector or tank 32' to any of the above described liquid filter devices 10a-c depicted as 'first filter' in the drawing. Subsequently the filtered liquid is conveyed to the heat exchanger 38 to clean at least a portion of the heat exchanger surface, wherein the washed off fluff and liquid (and generated condensate) is collected in the condensate collector 32'.

**[0063]** Fig. 9b shows a configuration also comprising the single liquid collector 32' in the lower shell 56' of a base unit. In contrast to the configuration of Fig. 9a unfiltered liquid from the liquid collector 32' is pumped via the first pump 40 to an intermediate tank 62 of the treatment apparatus 2. In particular the intermediate tank 62 can be removable (e.g. a condensate drawer) such that a user may remove excess liquid from the treatment apparatus 2. Thus the intermediate tank 62 may be used to temporarily store unfiltered liquid or to remove liquid from the apparatus. Liquid from the intermediate tank 62 may be fed via a valve 64 controlled by the control unit of the treatment apparatus to a liquid filter (which may be designed like or similar to any of the above liquid filter devices 10a-c). After filtering, the filtered liquid is conveyed to the heat exchanger 38 for cleaning. For example the intermediate tank 62 may be arranged at an upper portion of the treatment apparatus, i.e. above or higher than the liquid filter device 10a-c at the loading opening 6 of the treatment apparatus 2. Thus, when the valve 64 is opened, liquid flows due to gravity to the liquid filter device 10a-c. Alternatively a pump is provided controlled by the control unit of the treatment apparatus to pump liquid from the intermediate tank 62 to the liquid filter device 10a-c.

**[0064]** Fig. 9c shows a configuration comprising the basement shell or lower shell 56 as described above, i.e. the lower shell comprises the two tanks 32, 34 for separately collecting filtered and unfiltered liquid. Filtered liquid is collected in the intermediate tank 34, which may comprise the tunnel or drain conduit 36 as described above. Unfiltered liquid is collected in the condensate collector 32 as described above, and may be additionally pumped to an intermediate (removable) tank 62 (condensate drawer) as described above by means of the first pump 40. The first pump 40 is adapted to pump unfiltered liquid to any of the liquid filter devices 10a-c, wherein in contrast to the arrangements of Figs. 9a-b excess unfiltered liquid may be collected in the intermediate tank 62. The second pump 44 is provided to convey

filtered liquid from the intermediate tank to the heat exchanger 38 for cleaning, wherein the washed off fluff and condensate is collected in the condensate collector, i.e. liquid collector 32, as described above,

#### Reference Numeral List

#### [0065]

|         |                                 |
|---------|---------------------------------|
| 2       | laundry treatment apparatus     |
| 4       | drum                            |
| 6       | loading opening                 |
| 8       | front frame                     |
| 9a-c    | filter arrangement              |
| 10a-c   | liquid filter device            |
| 12a-6   | liquid filter mesh/net          |
| 14a-b   | liquid filter frame             |
| 16a-b   | hinge                           |
| 17a-b   | frame filter arrangement        |
| 18a-c   | air filter device               |
| 20a-d   | air filter mesh/net             |
| 22a-d   | air filter frame                |
| 24      | process air channel section     |
| 25      | seat filter arrangement         |
| 26      | liquid filter seat              |
| 28      | air filter seat                 |
| 30      | base unit                       |
| 32, 32' | liquid collector                |
| 34      | filtered liquid container       |
| 35      | filtered liquid container inlet |
| 36      | drain conduit/tunnel            |
| 38      | heat exchanger (evaporator)     |
| 40      | first pump (to liquid filter)   |
| 42      | feeding pipe                    |
| 43      | feeding pipe outlet             |
| 44      | second pump (to heat exchanger) |
| 46      | conveying pipe                  |
| 48a-b   | inclined filter base            |
| 49      | inclined filter seat base       |
| 50a-c   | grid                            |
| 52a-c   | liquid filter side wall         |
| 54a-b   | liquid filter lid               |
| 56, 56' | lower shell                     |
| 58      | upper shell                     |
| 60      | dividing wall                   |
| 62      | removable tank                  |
| 64      | valve                           |
| A       | filtered liquid                 |
| B       | unfiltered liquid               |
| C       | filtered liquid level           |

#### Claims

1. Laundry treatment apparatus, in particular dryer, condensate dryer, heat pump tumble dryer or washing machine having a dryer function, the apparatus comprising

a laundry treatment chamber (4) for treating laundry using process air,  
 a process air circuit for circulating the process air,  
 a heat exchanger (38) arranged in the process air circuit for cooling the process air, a conveying means (44, 46) connected to a liquid supply source adapted to convey liquid to a component of the laundry treatment apparatus for cleaning at least a portion of the component surface by removing fluff from the component surface,  
 a liquid collector (32) assigned to the component and adapted to collect liquid from the component,  
 a first filter device (10a-c) arranged in a process air section (24) of the process air circuit downstream the laundry treatment chamber (4), and  
 a feeding means (40, 42) adapted to supply liquid from the liquid collector (32) to the first filter device (10a-c),  
 wherein the first filter device (10a-c) is adapted to filter fluff from the supplied liquid,

2. Treatment apparatus according to claim 1, wherein the laundry treatment apparatus component is one of the following:

a component (38) of the heat pump system,  
 the heat exchanger (38),  
 a fluff filter,  
 a heating element,  
 a nozzle for introducing an agent into the processing air channel,  
 a plate of the process air channel, or  
 a heat exchanging plate forming a wall to the process air channel.

3. Treatment apparatus according to claim 1 or 2, wherein the first filter device (10a-c) is arranged in the process air section (24) of the process air circuit downstream the laundry treatment chamber (4) and upstream the laundry treatment apparatus component.

4. Treatment apparatus according to claim 1, 2 or 3, further comprising a second filter device (18a-c) arranged in the process air circuit downstream the laundry treatment chamber (4), wherein the second filter device (18a-c) is adapted to filter fluff from the process air.

5. Treatment apparatus according to any of the previous claims, comprising a filter arrangement (9a-c) located in the process air circuit downstream the laundry treatment chamber (4), wherein the filter arrangement (9a-c) comprises the first and second filter device (10a-c, 18a-c), or wherein the filter arrangement comprises the first filter device which is adapted to filter fluff from the supplied liquid and to filter fluff carried by the process

- air from the laundry treatment chamber.
6. Treatment apparatus according to any of the previous claims, wherein the first filter device (10a-c), the second filter device (18a-c) or the filter arrangement (9a-c) is arranged in or at the process air channel section (24) at a loading opening (6) of the laundry treatment chamber (4). 5
  7. Treatment apparatus according to any of the previous claims, wherein the process air channel section (24), in which the first filter device (10a-c), second filter device (18a-c) or filter arrangement (9a-c) is arranged, is formed in a front frame (8) of the apparatus (2). 10
  8. Treatment apparatus according to any of the previous claims, wherein the first and second filter device are combined in a single filter element of the filter arrangement (9a), or wherein the first filter device is a portion of the second filter device, or wherein the first filter device is further adapted to filter fluff from the process air. 15
  9. Treatment apparatus according to any of the previous claims, wherein the first filter device (10b) has a shielding element (54a-b) adapted to deflect the process air flow such that no process air or only a reduced process air flow is entering or passing the first filter device (10b). 20
  10. Treatment apparatus according to any of the previous claims, wherein the first filter device (10a-c), the second filter device (18a-c) or the filter arrangement (9a-c) is removably arranged in the laundry treatment apparatus (2). 25
  11. Treatment apparatus according to any of the previous claims, wherein the first filter device (10b) and the second filter device (18b) are combined in the filter arrangement (9b) and the first filter device (10b) is detachable from the filter arrangement (9b) or from the second filter device (18b) for cleaning. 30
  12. Treatment apparatus according to any of the previous claims, wherein the first filter device (10a-c) comprises a liquid filter element (12a-b) arranged at a bottom or lower portion of the filter device (10a-c). 35
  13. Treatment apparatus according to any of the previous claims, wherein at least a portion of the first filter device is a portion of the process air filtering section of the second filter device. 40
  14. Treatment apparatus according to any of the previous claims, further comprising a filtered liquid container (34) assigned to the first filter device (10a-c) or filter arrangement (9a-c) and adapted to collect the liquid from the first filter device (10a-c) or filter arrangement (9a-c). 45
  15. Treatment apparatus according to any of the previous claims, wherein the liquid collector (32) and the filtered liquid container (34) are arranged in a base unit (30) of the treatment apparatus (2). 50
  16. Treatment apparatus according to any of the previous claims, wherein the filtered liquid container (34) is fluidly connected to the first filter device (10a-c) or filter arrangement (9a-c) by means of a drain conduit (36), and at least a portion of the conduit (36) is arranged and passing at a side of the liquid collector (32), or at least a portion of the conduit (36) is arranged below the liquid collector (32), such that filtered liquid is conveyed to a rear portion of the base unit. 55
  17. Treatment apparatus according to any of the previous claims, wherein the feeding means (40, 42) comprises a first pump (40) for pumping liquid from the liquid collector (32) to the first filter device (10a-c) or to an intermediate tank fluidly connected to the first filter (10a-c), and wherein the conveying means (44, 46) comprises a second pump (44) for pumping liquid from the filtered liquid container (34) to the component. 55
  18. Treatment apparatus according to any of the previous claims, wherein the feeding means (40, 42) comprises a liquid conduit (42) having an outlet (43) or a nozzle arranged at the first filter device (10a-e) to spray the liquid to be cleaned in or on a liquid filtering element (12a-b) of the first filter device (10a-c). 55
  19. Treatment apparatus according to claim 22, wherein the liquid conduit (42) is at least partially formed in a front frame (8) of the apparatus (2) or is guided through the front frame (8) or is guided at least partially in the process air section (24) of the process air circuit. 55

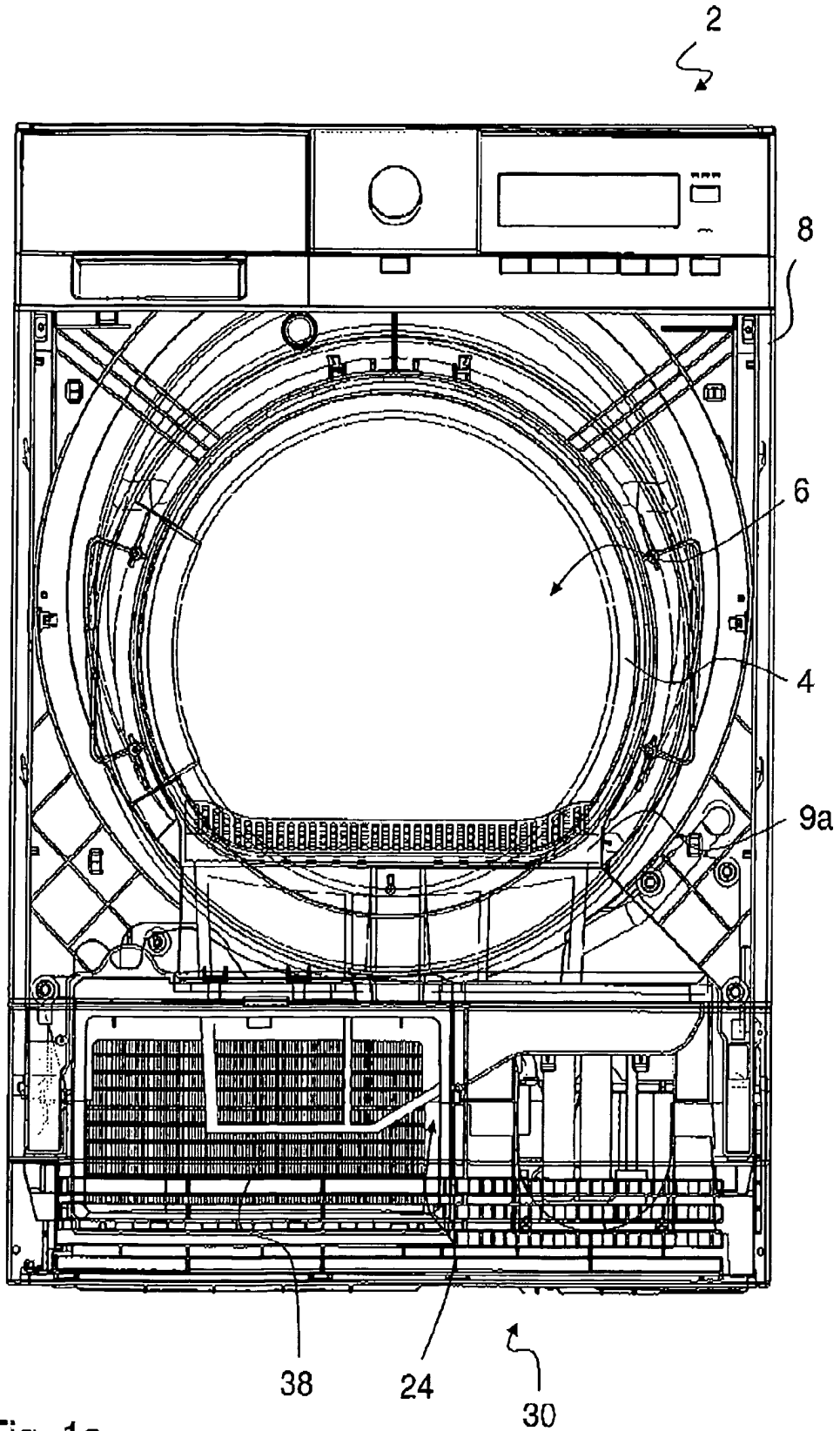



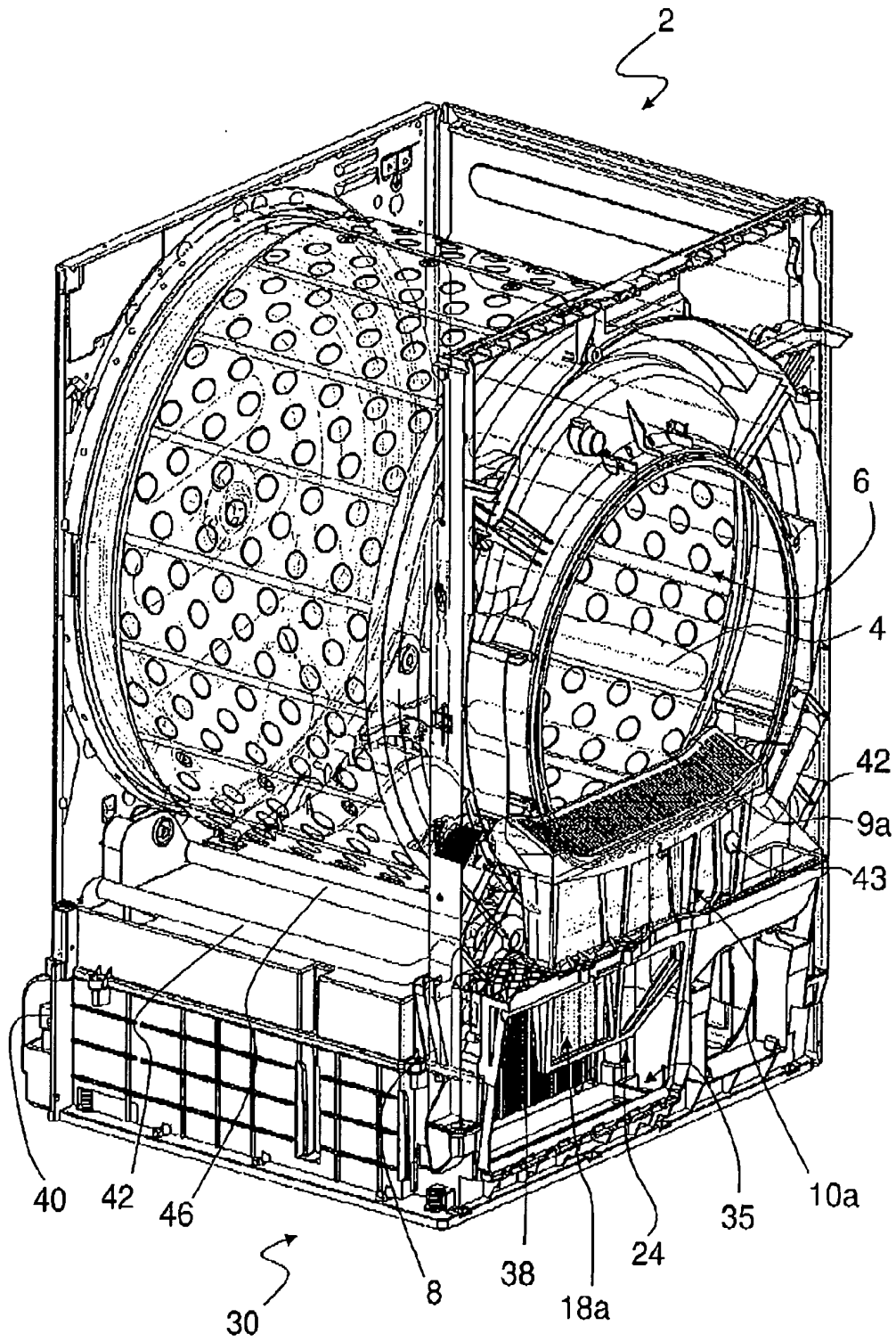

Fig. 1c

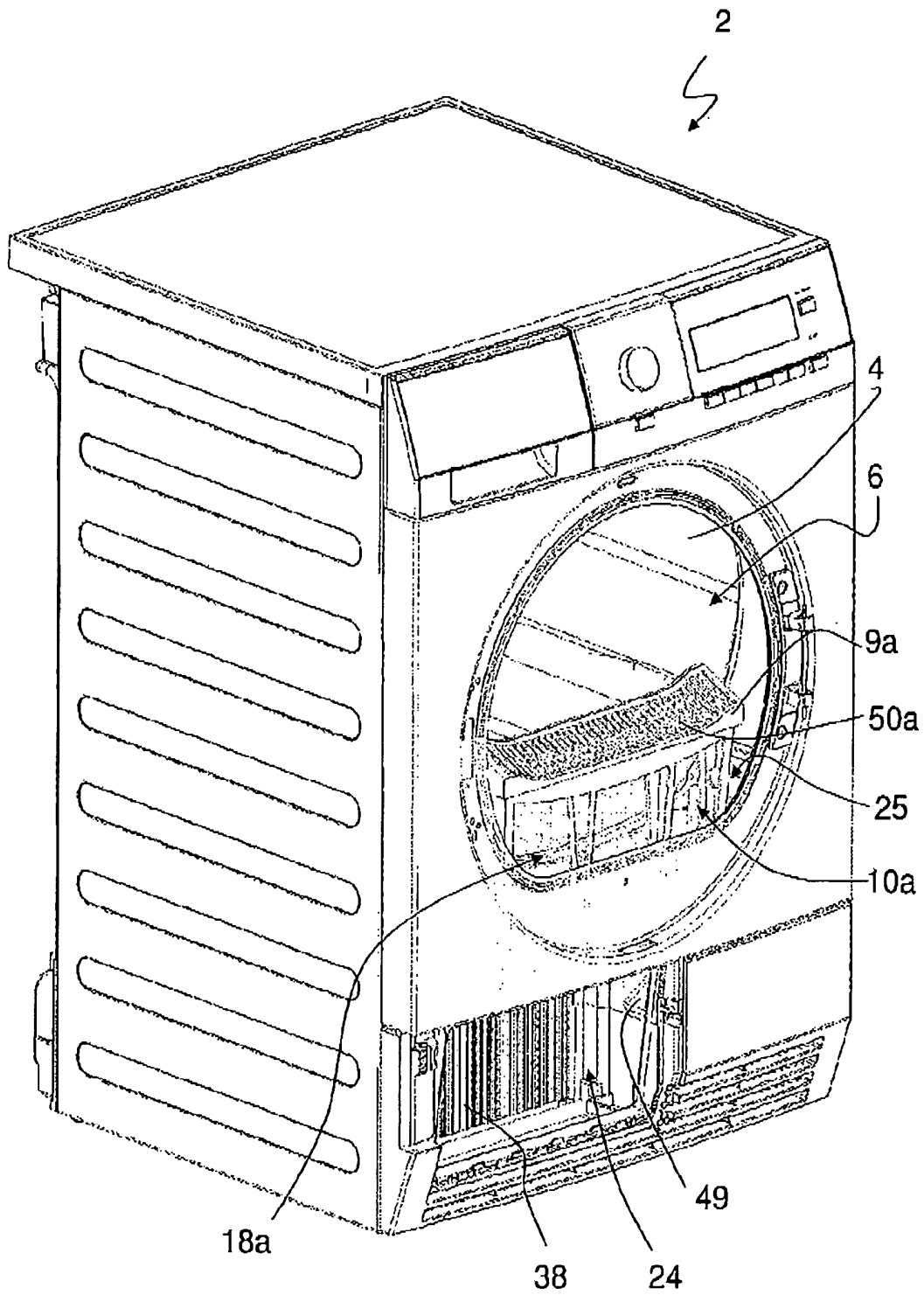

Fig. 2a

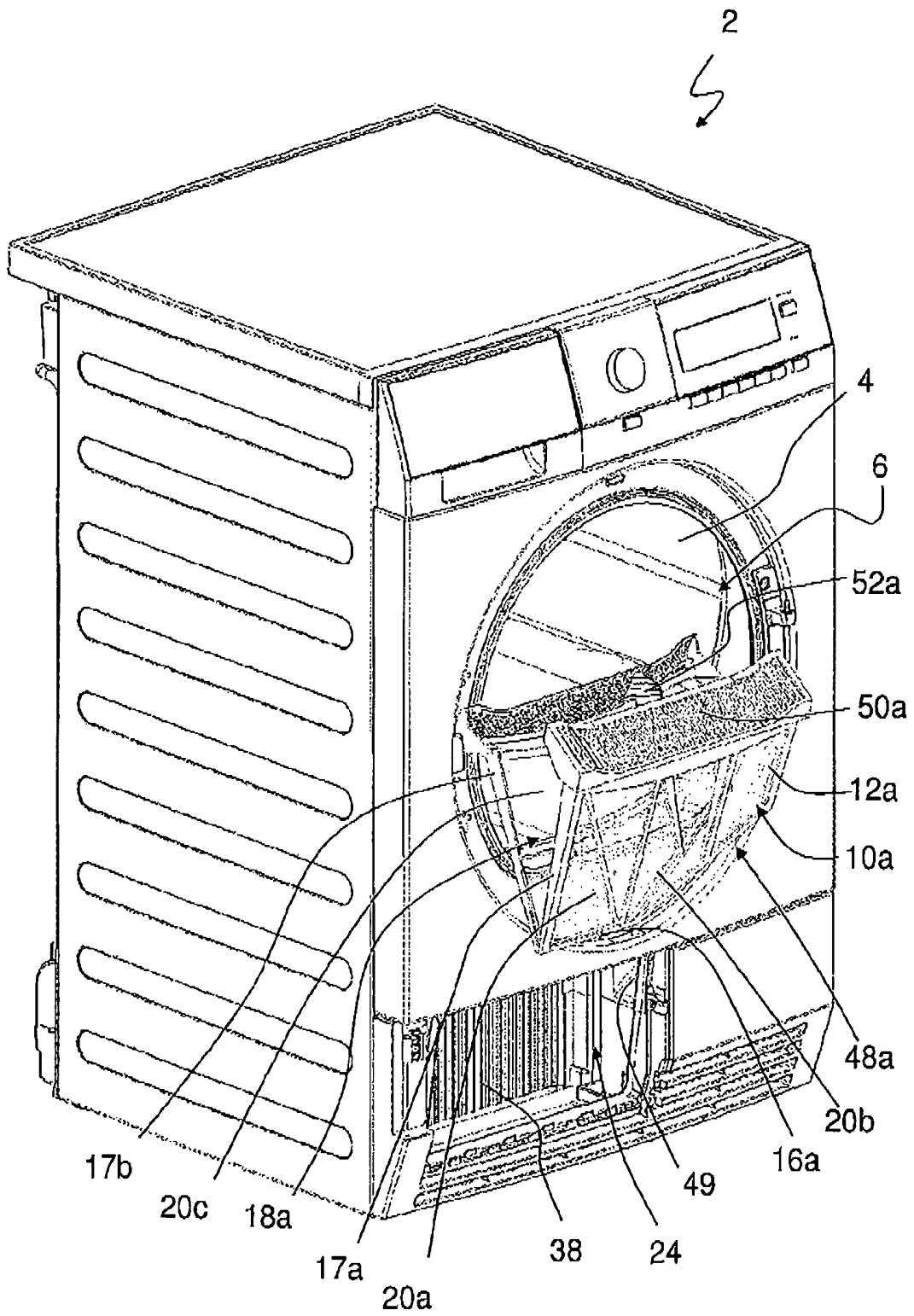
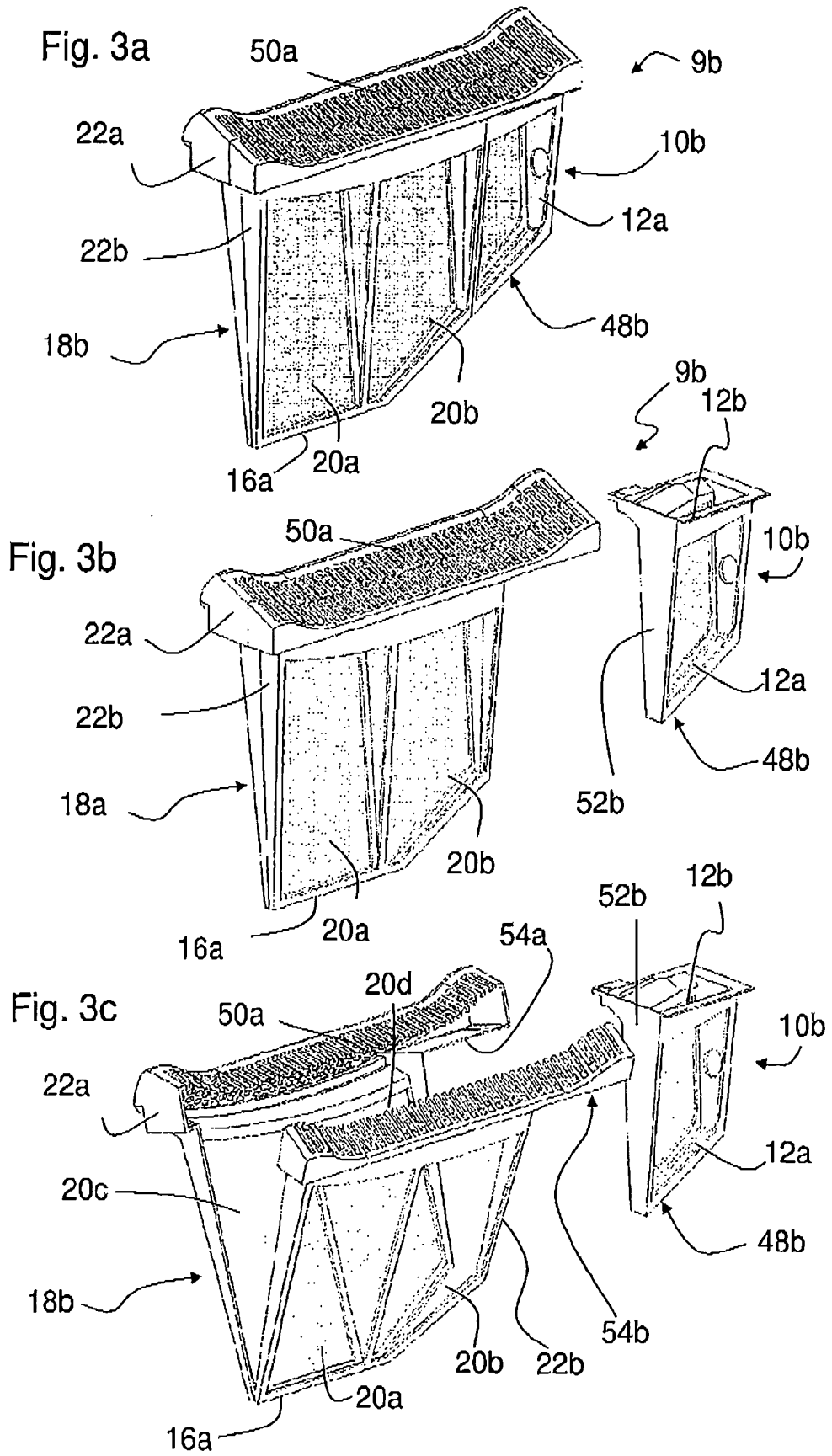

Fig. 2b



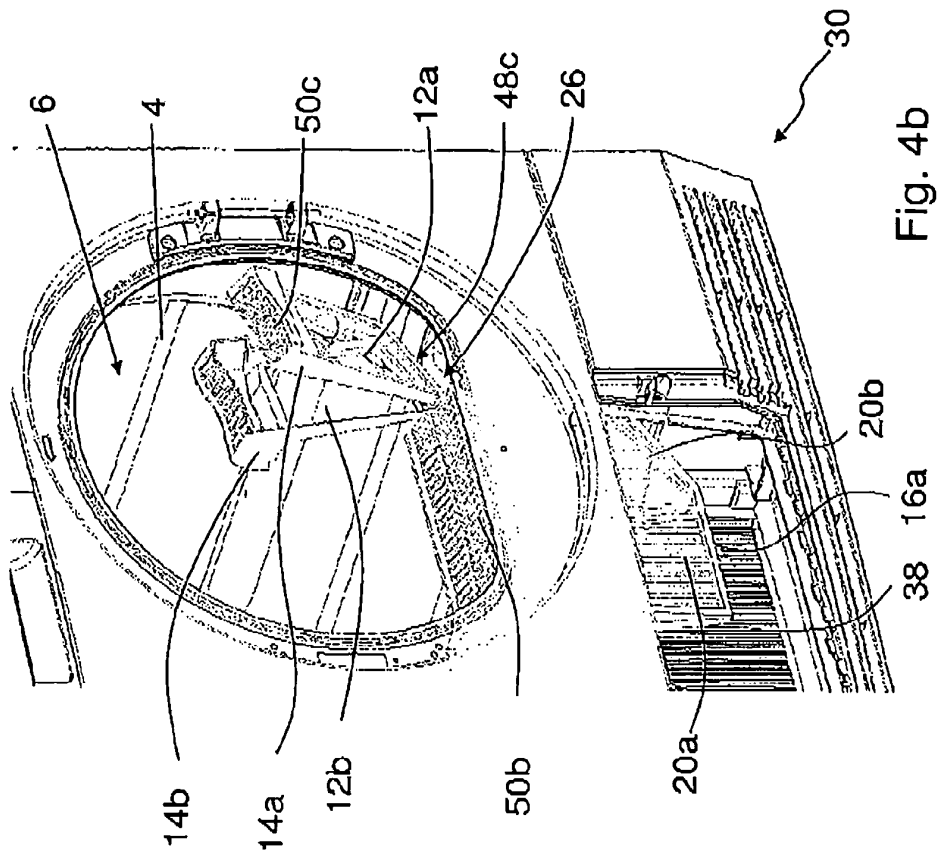

Fig. 4a

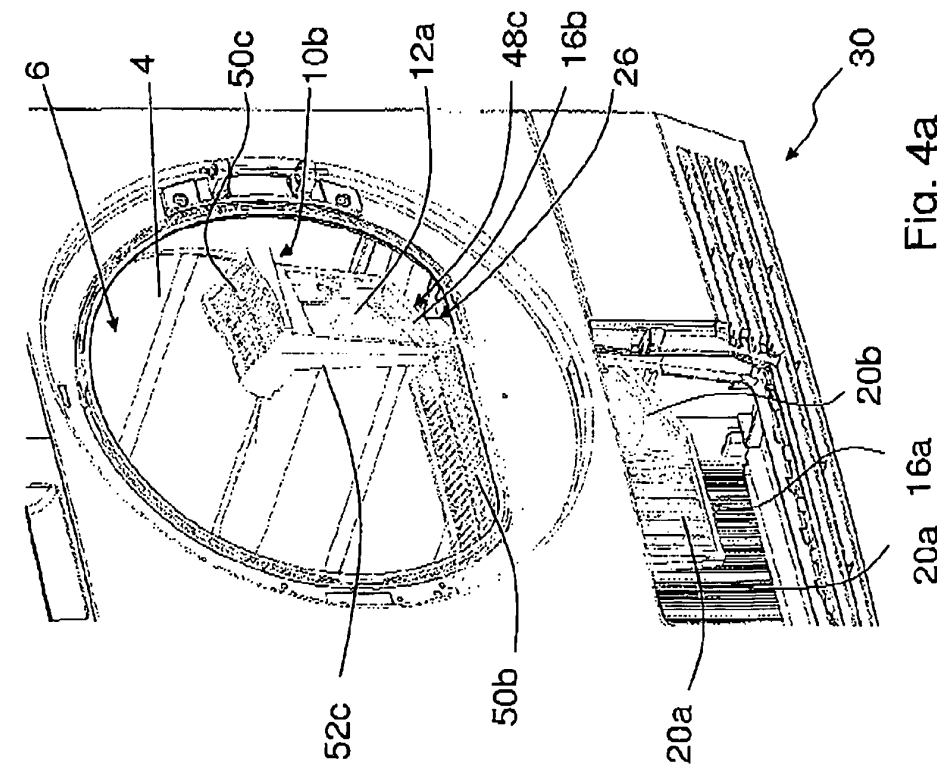
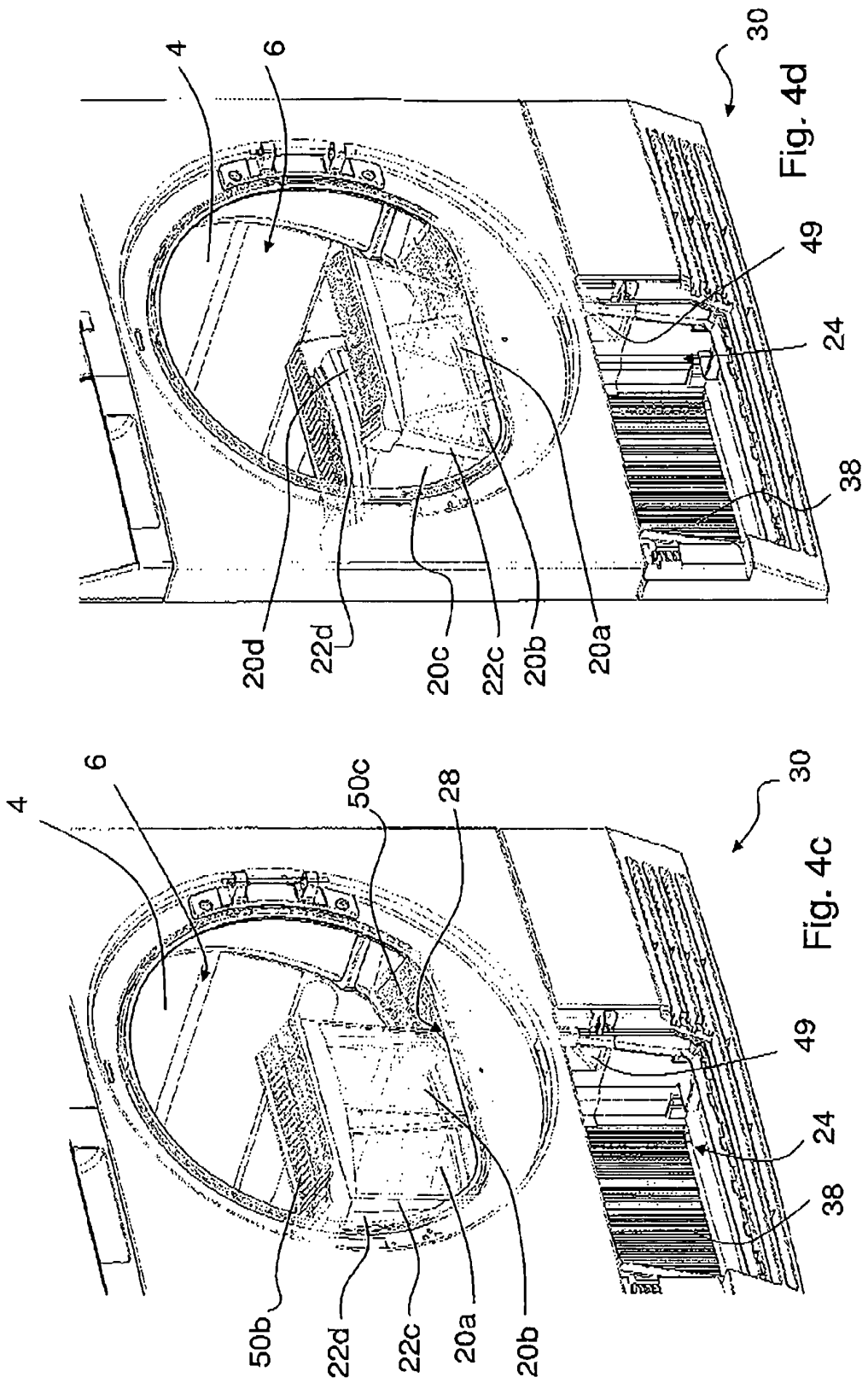

Fig. 4b



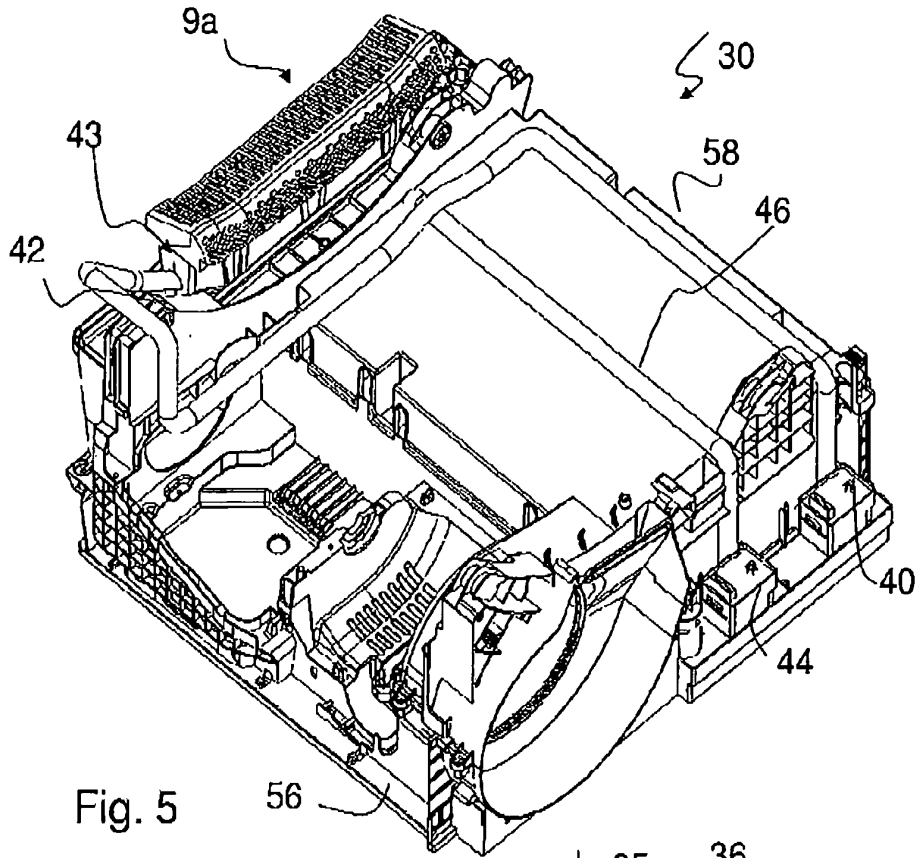

Fig. 5

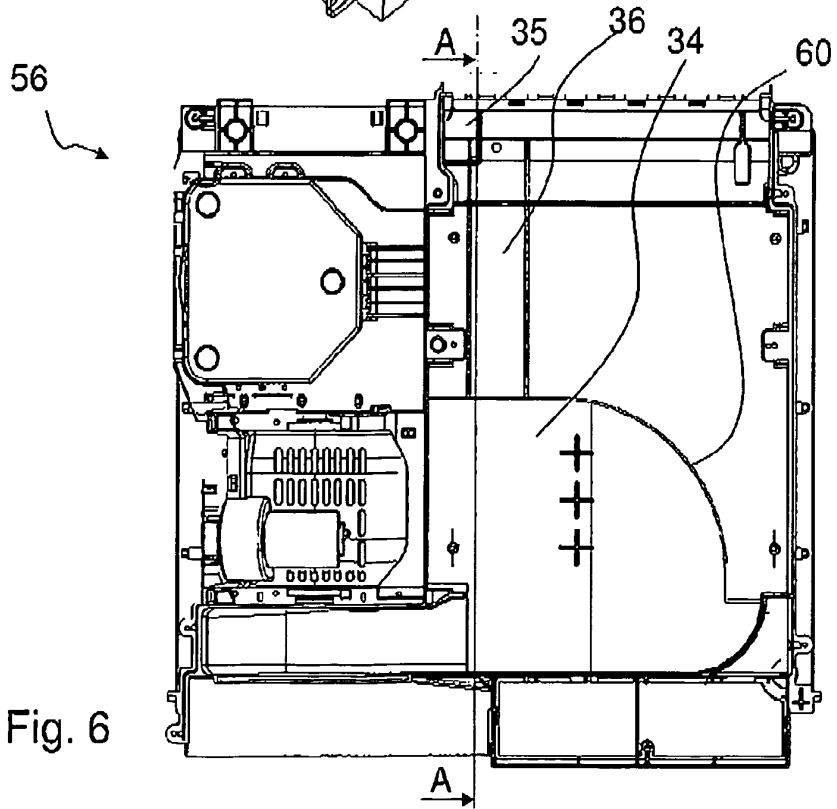

Fig. 6

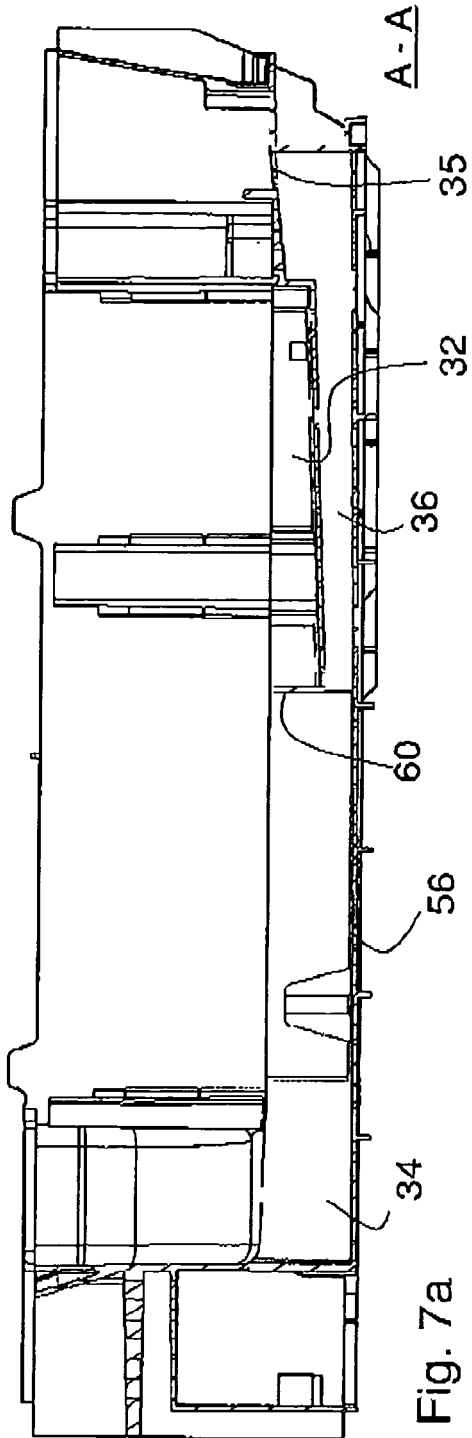

Fig. 7a

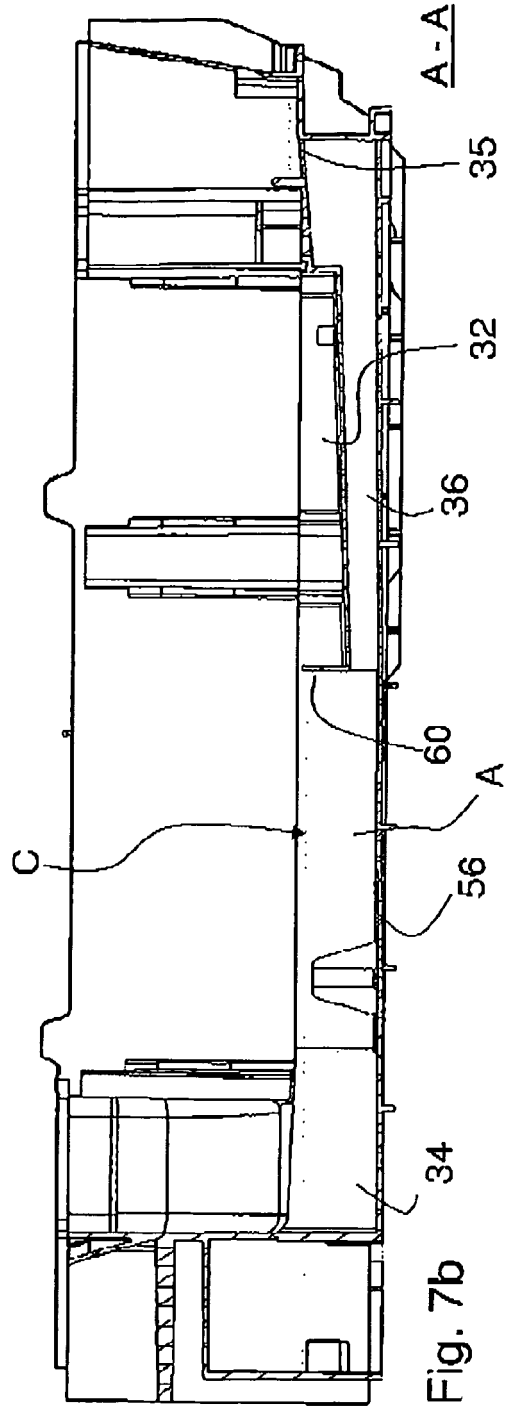

Fig. 7b

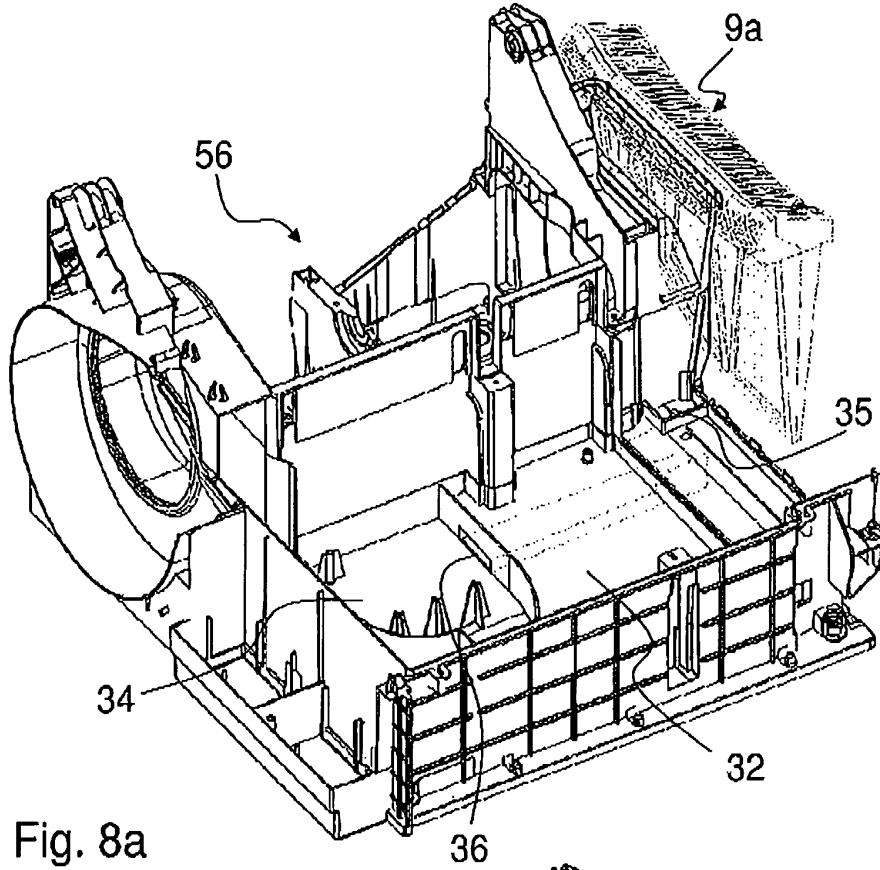

Fig. 8a

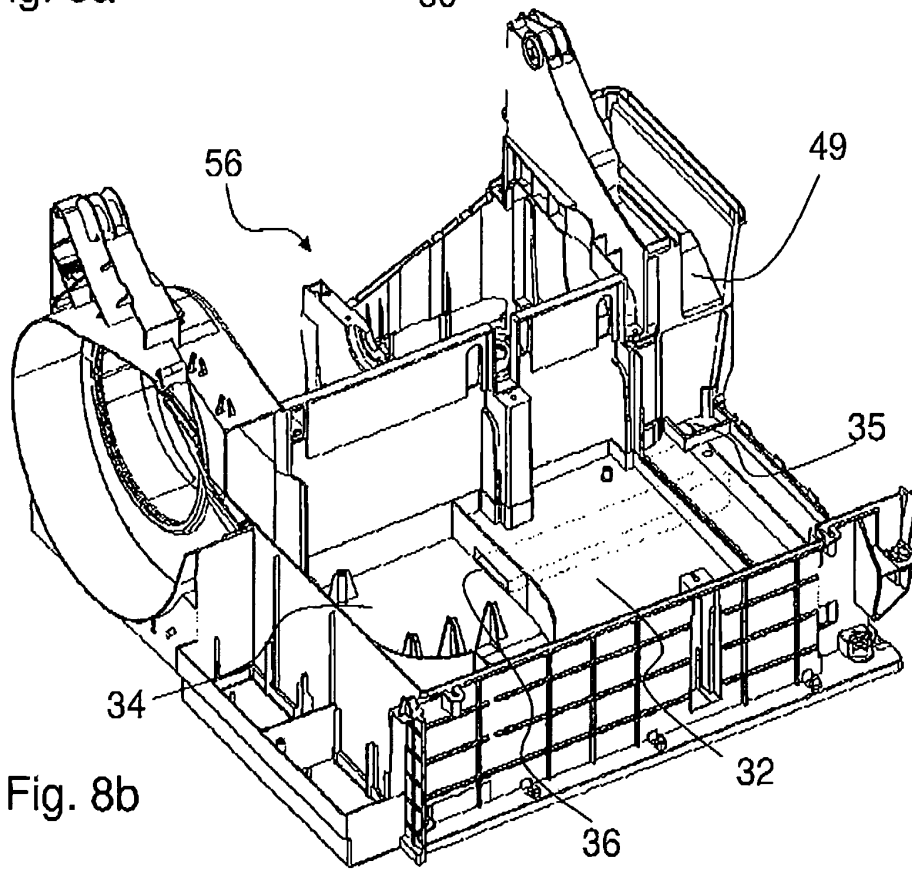

Fig. 8b

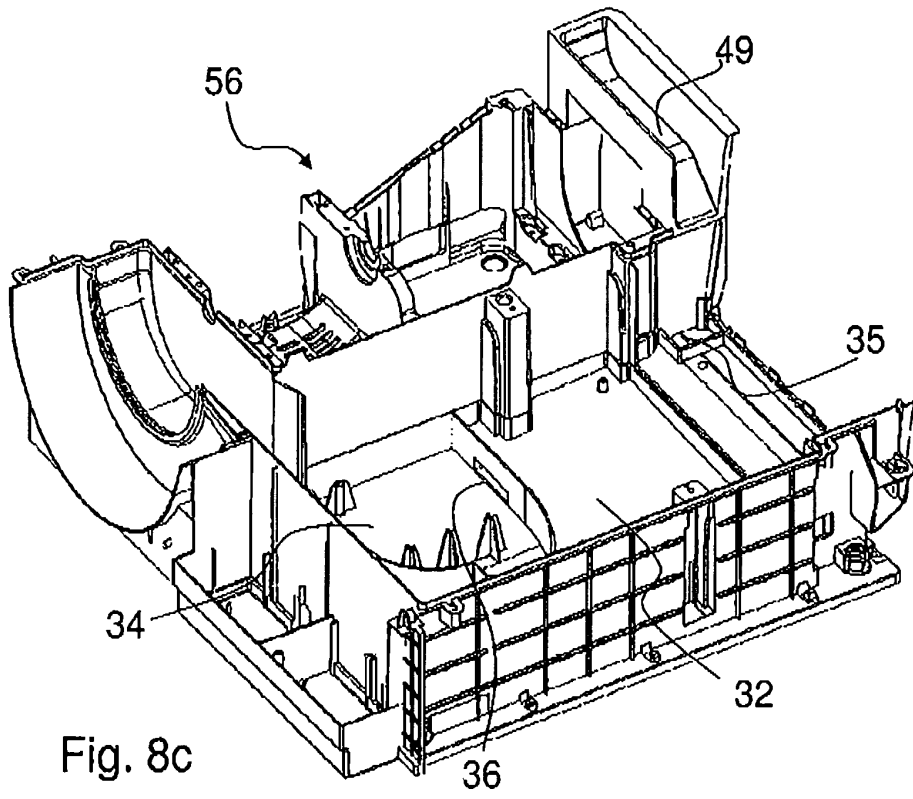

Fig. 8c

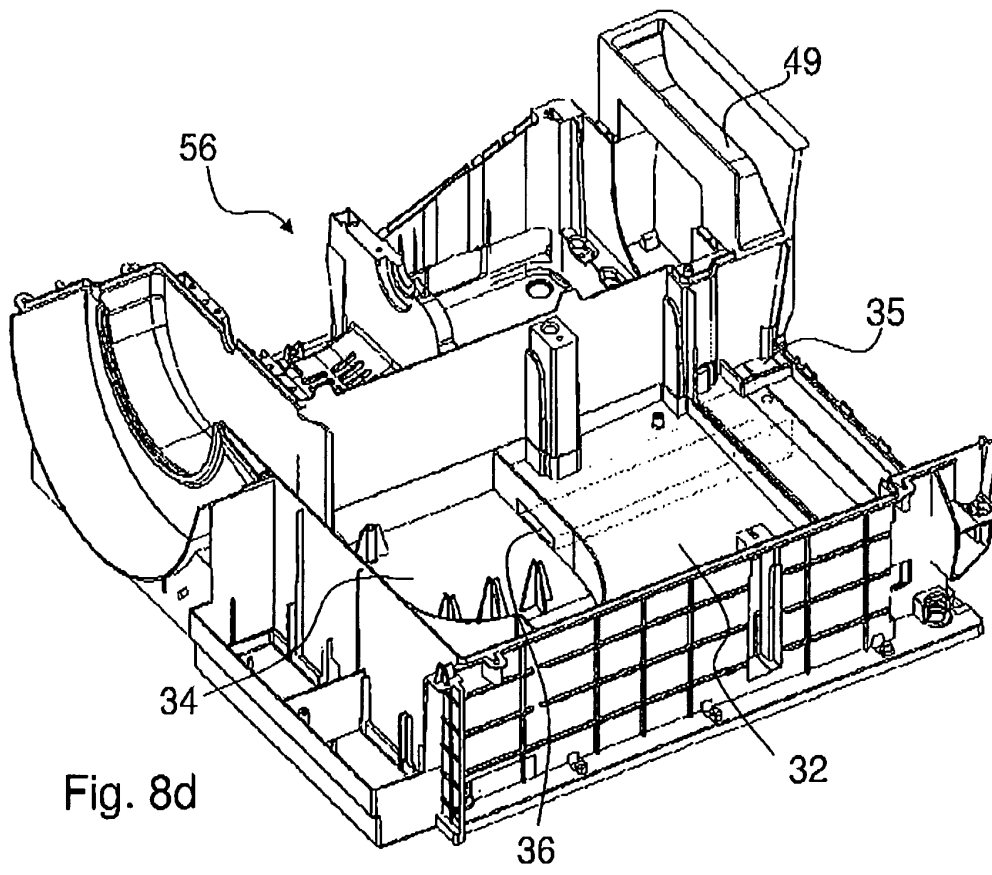
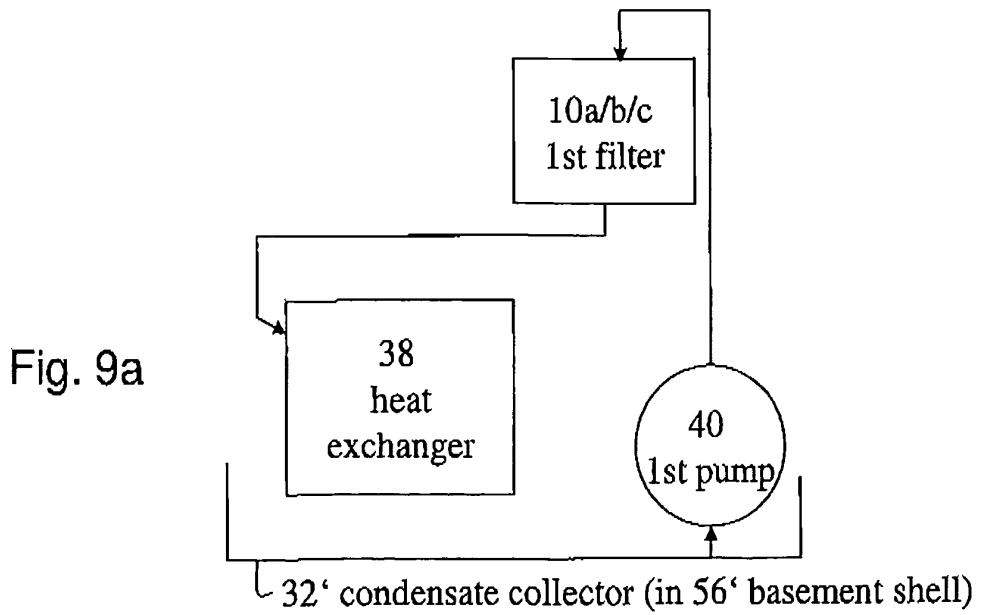
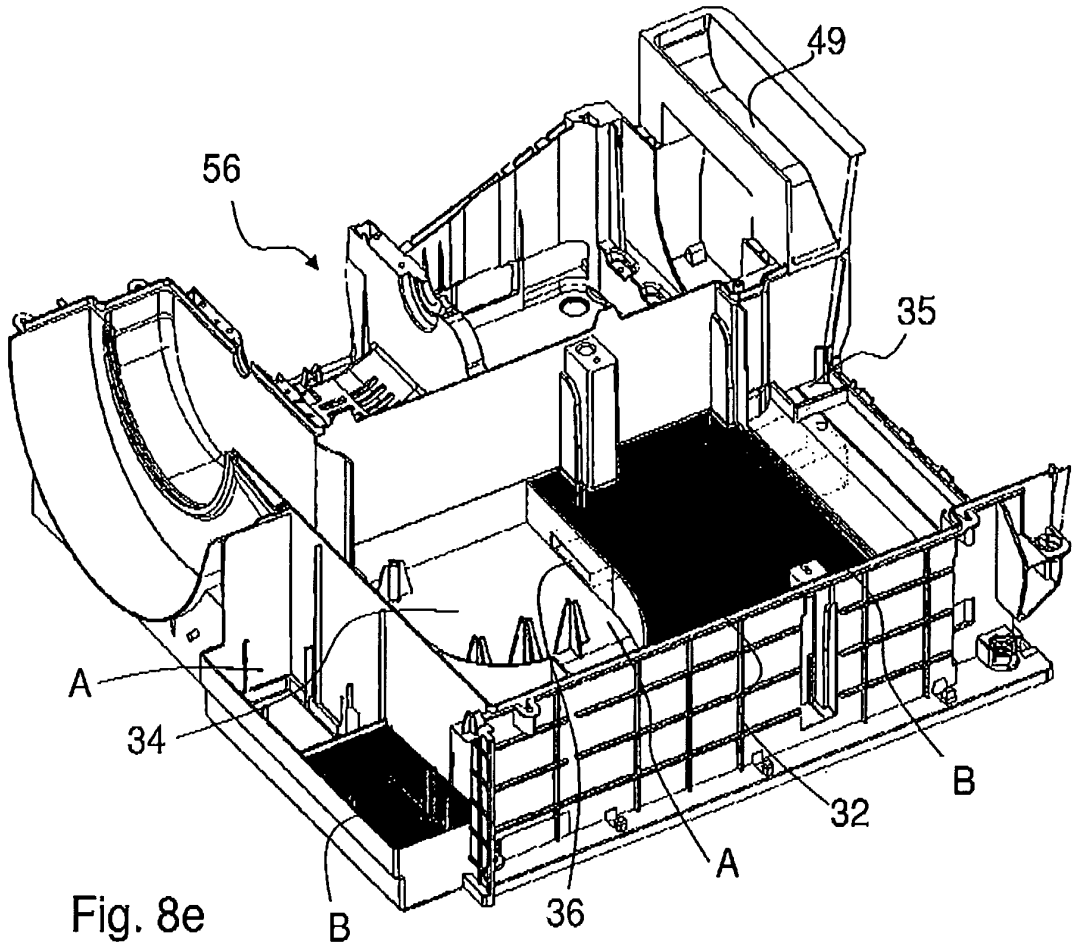

Fig. 8d



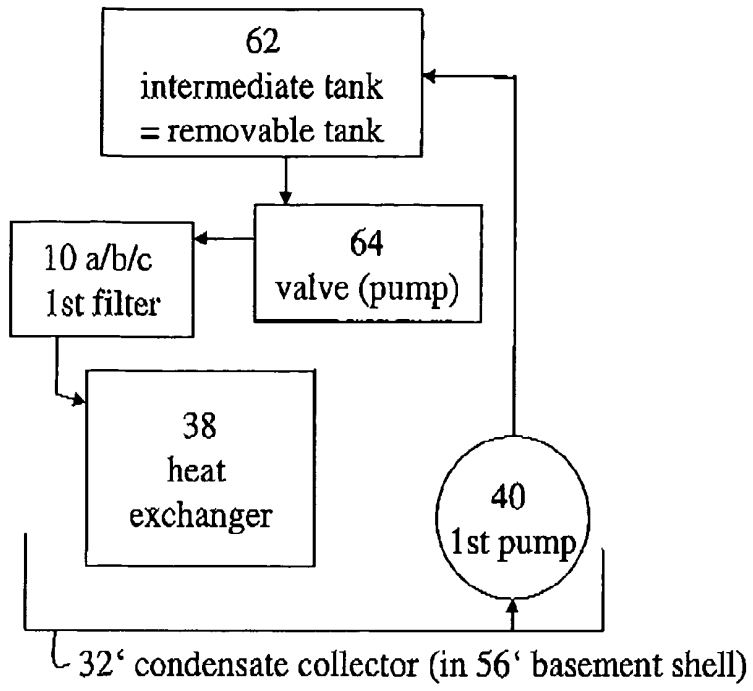

Fig. 9b

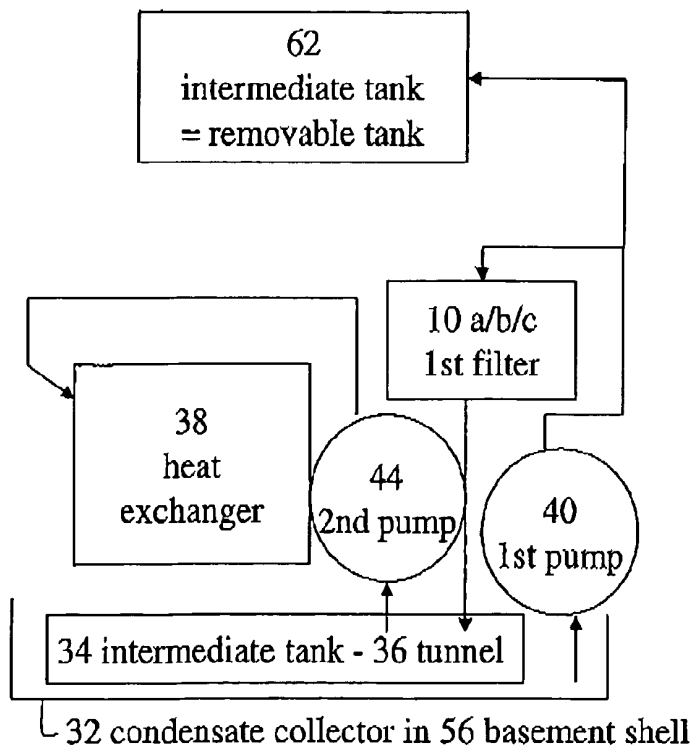

Fig. 9c



EUROPEAN SEARCH REPORT

Application Number  
EP 12 00 7131

| DOCUMENTS CONSIDERED TO BE RELEVANT  |   |   |   |
|--|---|---|---|
| Category   | Citation of document with indication, where appropriate, of relevant passages               | Relevant to claim   | CLASSIFICATION OF THE APPLICATION (IPC)     |
| X  | EP 2 314 758 A1 (CANDY SPA [IT])<br>27 April 2011 (2011-04-27)                              | 1-3,6,7,<br>10,12,<br>14-16,<br>18,19   | INV.<br>D06F58/22<br>D06F58/24<br>D06F58/20 |
| A  | * paragraphs [0001], [0002], [0012] - [0042]; claims; figures *<br>-----                    | 4,5,8,9,<br>11,13,17  |   |
| X  | DE 10 2010 039602 A1 (BSH BOSCH SIEMENS HAUSGERAETE [DE])<br>23 February 2012 (2012-02-23)  | 1-16,18,<br>19  |   |
| A  | * paragraphs [0001], [0023] - [0045], [0049]; figures *<br>-----                            | 17  |   |
| X,D  | DE 10 2008 054832 A1 (BSH BOSCH SIEMENS HAUSGERAETE [DE]) 1 July 2010 (2010-07-01)          | 1-5,14,<br>17   |   |
| A  | * paragraphs [0001], [0029] - [0037]; claims; figures *<br>-----                            | 6-13,15   |   |
| A  | DE 10 2009 001610 A1 (BSH BOSCH SIEMENS HAUSGERAETE [DE])<br>23 September 2010 (2010-09-23) | 1-19  | TECHNICAL FIELDS SEARCHED (IPC)             |
| A  | * paragraphs [0001], [0021] - [0027]; figures *<br>-----                                    |   | D06F  |
| A  | EP 0 816 549 A2 (CANDY SPA [IT])<br>7 January 1998 (1998-01-07)                             | 1-19  |   |
|  | * the whole document *<br>-----   |   |   |
| 1 The present search report has been drawn up for all claims   |   |   |   |
| Place of search<br>Munich  |   | Date of completion of the search<br>7 March 2013  | Examiner<br>Clivio, Eugenio                 |
| CATEGORY OF CITED DOCUMENTS<br>X : particularly relevant if taken alone<br>Y : particularly relevant if combined with another document of the same category<br>A : technological background<br>O : non-written disclosure<br>P : intermediate document |   | T : theory or principle underlying the invention<br>E : earlier patent document, but published on, or after the filing date<br>D : document cited in the application<br>L : document cited for other reasons<br>.....<br>& : member of the same patent family, corresponding document |   |

EPO FORM 1503 03.82 (P04/C01)

ANNEX TO THE EUROPEAN SEARCH REPORT  
ON EUROPEAN PATENT APPLICATION NO.

EP 12 00 7131

This annex lists the patent family members relating to the patent documents cited in the above-mentioned European search report.  
The members are as contained in the European Patent Office EDP file on  
The European Patent Office is in no way liable for these particulars which are merely given for the purpose of information.

07-03-2013

| Patent document<br>cited in search report | Publication<br>date | Patent family<br>member(s)  | Publication<br>date                                  |
|---|---------------------|---|--|
| EP 2314758 A1                             | 27-04-2011          | NONE  |  |
| DE 102010039602 A1                        | 23-02-2012          | DE 102010039602 A1<br>WO 2012022655 A1                              | 23-02-2012<br>23-02-2012                             |
| DE 102008054832 A1                        | 01-07-2010          | NONE  |  |
| DE 102009001610 A1                        | 23-09-2010          | NONE  |  |
| EP 0816549 A2                             | 07-01-1998          | DE 69712267 D1<br>DE 69712267 T2<br>EP 0816549 A2<br>IT MI961295 A1 | 06-06-2002<br>19-12-2002<br>07-01-1998<br>29-12-1997 |

EPO FORM P0459

For more details about this annex : see Official Journal of the European Patent Office, No. 12/82

**REFERENCES CITED IN THE DESCRIPTION**

*This list of references cited by the applicant is for the reader's convenience only. It does not form part of the European patent document. Even though great care has been taken in compiling the references, errors or omissions cannot be excluded and the EPO disclaims all liability in this regard.*

**Patent documents cited in the description**

- DE 102008054832 A1 [0002]