



(12) **EUROPEAN PATENT APPLICATION**

(43) Date of publication:
30.04.2014 Bulletin 2014/18

(51) Int Cl.:
E21B 43/12 (2006.01) **F04B 9/103** (2006.01)
F04B 47/08 (2006.01) **F04B 47/12** (2006.01)

(21) Application number: **12190177.1**

(22) Date of filing: **26.10.2012**

(84) Designated Contracting States:
AL AT BE BG CH CY CZ DE DK EE ES FI FR GB GR HR HU IE IS IT LI LT LU LV MC MK MT NL NO PL PT RO RS SE SI SK SM TR
 Designated Extension States:
BA ME

(72) Inventors:
 • **Hallunbæk, Jørgen**
3230 Græsted (DK)
 • **Vasques, Ricardo Reves**
2840 Holte (DK)

(71) Applicant: **Welltec A/S**
3450 Allerød (DK)

(74) Representative: **Hoffmann Dragsted A/S**
Rådhuspladsen 16
1550 Copenhagen V (DK)

(54) **Wireline pump**

(57) The present invention relates to a wireline pumping assembly (1) for being introduced in a wellbore (60) or a casing (61) and submerged in well fluid. The wireline pumping assembly extends in a longitudinal direction (50) and is adapted for connection with a wireline (60). Furthermore, the wireline pumping assembly comprises a pump section (2) comprising a tubular pump housing (20) providing a pump chamber (210); one or more inlets (21) provided in a lower part of the tubular pump housing; a first valve (22) for opening and closing the inlet; a plunger (23) being slidingly disposed in the pump chamber, the plunger comprising a second valve (242) controlling a flow of fluid from a first compartment (202) of the pump chamber below the plunger to a second compartment (203) of the pump chamber above the plunger; a pump rod operably connected to the plunger and extending from the plunger through the tubular pump housing; and one or more outlets (27) provided in an upper part of the tubular pump housing. The wireline pumping assembly further comprises a linear actuator (40) arranged in association with the tubular pump housing for driving the pump rod, whereby, when the wireline pumping assembly is at least partially submerged into the well fluid, well fluid is drawn into the tubular pump housing through the one or more inlets, forced through the second valve of the plunger, and expelled through the one or more outlets in the upper part of the tubular pump housing. Furthermore, the invention relates to a use of the wireline pumping assembly, a method of initiating a well using a wireline pumping assembly and a method of optimising an initiation operation.

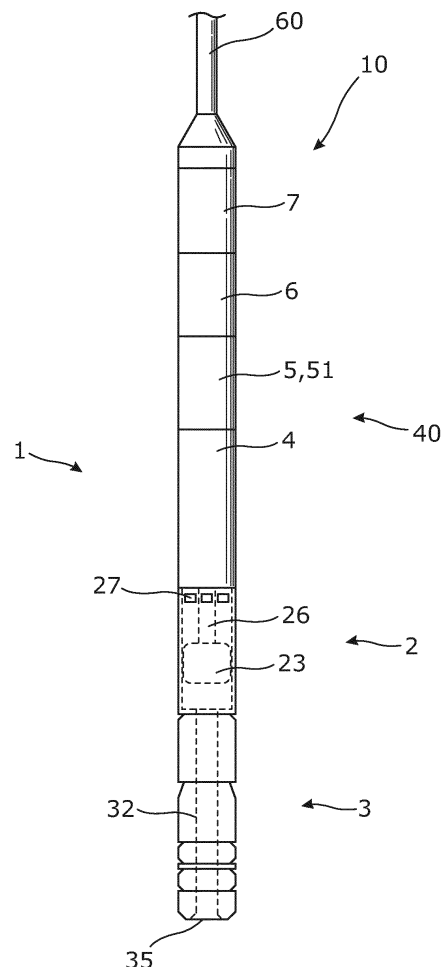

Fig. 1

DescriptionField of the invention

[0001] The present invention relates to a wireline pumping assembly for being introduced in a wellbore or a casing and submerged in well fluid. Furthermore, the invention relates to a use of the wireline pumping assembly, a method of initiating a well using a wireline pumping assembly and a method of optimising an initiation operation.

Background art

[0002] During oil and gas production, it is sometimes necessary to assist the production in a well due to a high hydro-static pressure. In situations where the well itself is not capable of generating the sufficient pressure to drive hydrocarbons to the surface, or where the well has been deliberately or unintentionally "killed", e.g. by the presence of water in the well, a tool may be used to lift the well fluid to the upper part of the well. Such tools are often referred to as artificial lift tools.

[0003] Artificial lift tools may be deployed in a well for longer or shorter periods of time depending on the specific conditions of the well. Sucker rod pumps are widely used to draw oil from underground formations. However, such pumps entail a large construction above ground as well as sucker rods extending all the way down through the well to a sub-surface rod pump provided in the well. These types of pumps may be suitable for use in wells requiring continuous pumping over longer periods of time. However, for operations requiring pumping action for only a limited period of time, the sucker rod pump concept is inexpedient due to the associated considerable investments. Further, in sea-based oil fields often situated at great depths, the concept of a sucker rod extending from a force generating installation at the surface to a pumping device downhole is ill-suited.

[0004] Because water has a higher density than hydrocarbons, the presence of water in a well may increase the hydro-static pressure, thereby preventing the pressure in the well from driving hydrocarbons to the surface. In situations where inflow of water has deliberately or unintentionally killed a well, downhole pumping action may be required to initiate or restart the well by removing water. Known systems for removing water, such as coiled tubing gas lifting, requires lots of surface equipment, such as coil spool and gas tanks. Further, pumps used in known well initiation systems often require high amounts of power which cannot be supplied via standard wireline cables. Special cables requiring additional surface equipment is therefore required, which makes such operations more complicated and expensive. A need therefore exists for a well initiation system which may be deployed using standard mono or multi-conductor wireline, requiring a minimum of surface equipment, planning and logistics.

Summary of the invention

[0005] It is an object of the present invention to wholly or partly overcome the above disadvantages and drawbacks of the prior art. More specifically, it is an object to provide an improved well initiation system and an associated method for initiating wells. Further, it is an object to provide a simple and reliable wireline pumping device which may be used for initialising wells which have been intentionally or unintentionally killed.

[0006] The above objects, together with numerous other objects, advantages, and features, which will become evident from the below description, are accomplished by a solution in accordance with the present invention by a wireline pumping assembly for being introduced in a wellbore or a casing and submerged in well fluid, the wireline pumping assembly extending in a longitudinal direction and being adapted for connection with a wireline, and the wireline pumping assembly comprising a pump section comprising:

- a tubular pump housing providing a pump chamber,
- one or more inlets provided in a lower part of the tubular pump housing,
- a first valve for opening and closing the inlet,
- a plunger being slidably disposed in the pump chamber, the plunger comprising a second valve controlling a flow of fluid from a first compartment of the pump chamber on one side of the plunger to a second compartment of the pump chamber on the other side of the plunger,
- a pump rod operably connected to the plunger and extending from the plunger through the tubular pump housing, and
- one or more outlets provided in an upper part of the tubular pump housing, wherein the wireline pumping assembly further comprises:
 - a linear actuator arranged in association with the tubular pump housing for driving the pump rod, whereby, when the wireline pumping assembly is at least partially submerged into the well fluid, well fluid is drawn into the tubular pump housing through the one or more inlets, forced through the second valve of the plunger, and expelled through the one or more outlets in the upper part of the tubular pump housing.

[0007] Hereby, a simple and reliable pumping device is provided which is capable of running using standard wireline and capable of pumping well fluids downhole. Further, as the pumping device is deployable using standard wireline, the amount of equipment needed to deploy the device is substantially reduced compared to known techniques for performing pumping operations downhole.

[0008] In an embodiment, the first valve may be a standing valve fixed in relation to the tubular pump housing and the second valve may be a travelling valve movable with the plunger in relation to the tubular pump hous-

ing.

[0009] In another embodiment, the linear actuator may comprise:

- a tubular stroker cylinder providing one or more piston housings,
- one or more piston elements slidingly disposed in the piston housing to divide the piston housing into a first chamber and a second chamber,
- a stroker shaft operably connected to the piston element for connection with the pump rod to provide reciprocation of the plunger,
- a pump for alternately supplying hydraulic fluid under pressure to the first chamber and the second chamber of the tubular stroker cylinder to reciprocate the piston element in the tubular stroker cylinder, and
- an electrical motor for driving the pump.

[0010] Furthermore, the linear actuator may comprise a plurality of piston elements slidingly disposed in a plurality of piston housings and operably connected to the stroker shaft.

[0011] Moreover, the linear actuator may comprise an electric linear motor and a stroker shaft driven by the electric linear motor for connection with the pump rod to provide reciprocation of the plunger,

[0012] In an embodiment, the wireline pumping assembly may be adapted to pump at a flow rate of approximately 5-15 litres per minute, preferably.

[0013] In another embodiment, the wireline pumping assembly may further comprise a plug device for providing a seal in an annulus between the wireline pumping assembly and the casing, the plug device comprising a base part connected with the tubular pump housing and having a through-going bore, and one or more sealing elements disposed around the base part, extendable from the base part for sealing off the annulus.

[0014] Hereby, a simple and reliable pumping device is provided which is capable of running using standard wireline and capable of initiating a well by pumping well fluids from one side of the plug device to the other side, whereby water may be removed. Further, as the pumping device is deployable using standard wireline, the amount of equipment needed to deploy the device is substantially reduced compared to known techniques for initiating wells. The reduced need for equipment greatly reduces the complexity of the initiation operation, thereby reducing the time and cost of such operations.

[0015] In yet another embodiment, the plug device may further comprise an anchor mechanism for fixating the wireline pumping assembly in the well, the anchor mechanism being slidingly disposed around the base part and comprising a plurality of setting slips extendable from the base part in a substantial radial direction for engagement with the tubing or casing.

[0016] Furthermore, the plug device may further comprise a compression sleeve slidingly disposed around the base part for compressing the one or more sealing

elements, and the sealing elements may be adapted to extend from the base part to seal off the annulus when the compression sleeve is displaced in the longitudinal direction towards the one or more sealing elements, thereby applying a compression force to the one or more sealing elements.

[0017] Moreover, the compression sleeve may comprise a cone-shaped section facing towards the anchor mechanism, the cone-shaped section being adapted to force the setting slips in a radial direction, at least upon activation of the anchor mechanism, when the plurality of setting slips are displaced towards the compression sleeve thereby engaging the cone-shaped section.

[0018] In addition, the compression sleeve may be adapted to be displaced by displacement of the anchor mechanism, resulting in a subsequent compression of the sealing elements by the compression sleeve.

[0019] In an embodiment, the wireline pumping assembly may further comprise an equalisation valve for equalising a differential pressure across the plug, at least prior to disengaging of the plug, when the plug device is set in a well.

[0020] Furthermore, the plug device may comprise the equalisation valve.

[0021] Moreover, the wireline pumping assembly may further comprise one or more sensors for measuring a differential pressure across the plug device when the plug device is set in a well.

[0022] Additionally, the wireline pumping assembly may further comprise an anchor section for anchoring the wireline pumping assembly in the well, the anchor section comprising a plurality of hydraulic activatable anchoring elements extendable from the tool body, for engagement with the casing.

[0023] Also, the wireline pumping assembly may further comprise a driving unit for driving the wireline pumping assembly forward in deviated wells.

[0024] In one embodiment, the wireline pumping system may comprising a wireline pumping assembly as described above, and a plug device for providing a seal in an annulus between the plug device and the casing, the plug device comprising a base part having a through-going bore adapted to be connected with the tubular pump housing of the pump section, and one or more sealing elements disposed around the base part, extendable from the base part for sealing off the annulus, wherein the wireline pumping assembly being adapted for connection with the plug device downhole following setting of the plug device in the well.

[0025] The present invention furthermore relates to a use of the wireline pumping assembly as described above or the wireline pumping system described above for initiation of a killed well by removing water or mud present in the well using the pumping action provided by the pumping assembly.

[0026] Moreover, the present invention relates to a method of initiating a well using a wireline pumping assembly as described above, comprising the steps of:

- inserting the wireline pumping assembly into the wellbore,
- setting the plug device for providing a seal in an annulus between the plug device and the casing, the plug device comprising:
 - a base part having a through-going bore adapted to be connected with the tubular pump housing of the pump section, and
 - one or more sealing elements disposed around the base part, extendable from the base part for sealing off the annulus,
- operating the pumping section of the wireline pumping assembly to pump fluid past the plug device until a pressure below the plug device is sufficient to make the well run by itself,
- equalising the pressure over the plug by operating the equalisation valve, and
- removing the wireline pumping assembly from the well.

[0027] The method may further comprise the step of removing the plug device from the well.

[0028] Finally, the present invention relates to a method of optimising an initiation operation, comprising the step of:

- determining a pressure level in the well below the plug device, sufficient to make the well run by itself,
- continuously monitoring the pressure in the well below the plug device while the pumping section is operated to pump fluid from below the plug device to above the plug device, and
- determining when the predetermined pressure level is reached, following which the operation of the pumping section may be stopped.

Brief description of the drawings

[0029] The invention and its many advantages will be described in more detail below with reference to the accompanying schematic drawings, which for the purpose of illustration show some non-limiting embodiments and in which

Fig. 1 shows a wireline pumping assembly,

Fig. 2 shows a cross-section of one embodiment of a pumping section of the wireline pumping assembly,

Fig. 3a shows a cross-section of one embodiment of a plug device of the wireline pumping assembly,

Fig. 3b shows a cross-section of another embodiment of a plug device of the wireline pumping assembly,

Fig. 4a shows a cross-section of one embodiment of a linear actuator,

Fig. 4b shows a cross-section of another embodiment of a linear actuator,

Fig. 5a shows the wireline pumping assembly of Fig. 1 in a set condition inside a casing downhole,

Fig. 5b shows a close-up of a lower section of the wireline pumping assembly shown in Fig. 5a, and

Fig. 6 shows another embodiment of the wireline pumping assembly comprising a driving unit and an anchor section.

[0030] All the figures are highly schematic and not necessarily to scale, and they show only those parts which are necessary in order to elucidate the invention, other parts being omitted or merely suggested.

Detailed description of the invention

[0031] Fig. 1 shows a wireline pumping assembly 1 comprising a pump section 2, a plug device 3, a linear actuator 40 and an electronic section 7. The wireline pumping assembly is a downhole assembly adapted to be suspended in a well using a wireline 60 operably connected at a top end of the wireline pumping assembly. At the bottom end of the wireline pumping assembly, the plug device is arranged in continuation of the pump section. The plug device may be an integrated part of the wireline pumping assembly or adapted to be releasably connected with the wireline pumping assembly downhole.

[0032] The pump section 2 is operably connected to the linear actuator 40, and the linear actuator provides the power input required to drive the pump unit 2. The wireline pumping assembly is powered through the wireline 60, and the electronic section controls the powering and operation of the remainder of the wireline pumping assembly.

[0033] Fig. 2 shows a pumping section of the wireline pumping assembly, comprising a tubular pump housing 20 also constituting a tool housing. The pump housing 20 defines a pump chamber 201. A lower part of the pump housing is provided with inlets 21 in fluid communication with the pump chamber 201, and an upper part of the pump housing is provided with a plurality of outlets 27 in fluid communication with the pump chamber. Further, in a lower part of the tubular pump housing, a first valve 22, such as a standing valve is arranged for controlling the flow of fluid through the inlet 21. In the pump chamber 201, a plunger 23 is slidingly disposed, thereby dividing the pump chamber into a first compartment 202 and a second compartment 203. To control the flow of fluid from the first compartment 202, past the plunger 23 to the second compartment 203, the plunger is provided with a

second valve 24, such as a travelling valve. The pump section 2 further comprises a pump rod 26 operably connected to the plunger and extending from the plunger through the tubular pump housing for connection with a stoker shaft 45 of the linear actuator.

[0034] The wireline pumping assembly further comprises a linear actuator 40 arranged in association with the tubular pump housing, as shown in Fig. 1. As shown in Fig. 4a, the linear actuator comprises a tubular stoker cylinder 4 defining a piston housing 47 and a piston element 46 slidably disposed in the piston housing to divide the piston housing into an first chamber 41 and a second chamber 42. A stoker shaft 45 extending from the piston element is operably connected with the pump rod of the pump section, as described above, to provide reciprocation of the plunger in the pump chamber. The linear actuator further comprises a pump 5 (not shown in Fig. 4a) for alternately supplying hydraulic fluid under pressure to the first chamber 41 and the second chamber 42 of the tubular stoker cylinder, and an electrical motor 6 is provided for driving the pump. When fluid is alternately supplied to the first chamber 41 and a second chamber 42, the piston element is reciprocated in the tubular stoker cylinder, thereby creating a linear motion. The linear motion is transferred via the stoker shaft 45 to the pump rod 26, thereby reciprocating the plunger in the pump chamber. When the plunger is reciprocated, a pumping effect is created in the pump section and, provided that the wireline pumping assembly is at least partially submerged into a well fluid, well fluid is drawn into the pump chamber 201 through the one more inlets in the lower part of the tubular pump housing, forced through the second valve of the plunger, and expelled through the plurality of outlets in the upper part of the tubular pump housing. In another embodiment (not shown), the pump housing 20 may be provided as a separate pump housing inside a tubular tool housing.

[0035] More specifically, during an upstroke motion, the plunger moves away from the inlet 21 and the first valve 22, resulting in well fluid being sucked in through the inlet 21, past the open first valve 22 and into the first compartment 202 of the pump chamber. The first valve is a check-valve only allowing fluid to flow into the pump chamber. Thus, as the plunger 23 reaches an upper extreme position, the first compartment of the pump chamber has been flooded. A subsequent downstroke motion of the plunger, wherein the plunger moves towards the inlet 21 and the first valve 22, forces the fluid through the travelling valve 24 of the plunger and into the second compartment 203 of the pump chamber. During the next upstroke motion, the fluid in the second compartment 203 is expelled out through the plurality of outlets in the tubular pump housing as the second valve prevents fluid from flowing in the direction towards the first compartment 202. In the shown embodiment, the first valve and the second valve are embodied as check-valves of the ball-type and comprise a displaceable valve ball 221, 241 cooperating with a valve seat 222, 242 to control the flow

direction. However, the skilled person would know that many other types of valves may be envisaged providing similar functionality. Further, the design of the pump section is based on the principles of widely used rod pumps, and other designs of the pump section may thus be envisaged by the skilled person without departing from the invention.

[0036] Details about the design of the linear actuator are shown in Figs. 4a and 4b showing different embodiments of a linear actuator. In both embodiments, the stoker shaft 45 extends through the tubular stoker cylinder 4 sectioned into one or more piston housings 47 by partitions 48. The partitions comprise a sealing means 49b, such as an O-ring, in order to provide a sealing connection between the partitions and the stoker shaft 45. In each of the piston housings 47, a piston element 46 is provided around the stoker shaft 45 so that the stoker shaft 45 may run back and forth within the tubular stoker cylinder 4 to provide the linear motion. Each of the piston elements 46 divides each of the one or more piston housings into an first chamber 41 and a second chamber 42, and the piston elements are provided with sealing means 49a in order to provide a sealing connection between the inside of the piston housing 47 and the outside of the piston element 46. As shown in Fig. 4a, fluid is alternately supplied to the first chamber 41 and the second chamber 42 via the respective fluid channels 43, 44. In the embodiment shown in Fig. 4b, only the fluid channels in fluid communication with the first piston housing is shown, however, the other piston housings are provided with a similar arrangement of fluid channels. To provide the linear motion of the linear actuator, the pump 5 pumps fluid into the first chamber by sucking a corresponding amount of fluid from the second chamber 42, and vice versa. When the first chamber 41 is substantially filled, the pump 5 shifts its pumping direction and pumps fluid from the first chamber 41 into the second chamber 42. Consequently, the piston element 46 is forced in the opposite direction. Consequently, the stoker shaft 45 is forced back and forth, thereby providing the linear motion. As can be seen in Fig. 4a, the first chamber 41 is provided with a fluid channel 43 at one end of the piston housing 47, and the second chamber 42 is provided with a fluid channel 44 at the opposite end of the piston housing 47. In this way, fluid can be sucked or pumped into each chamber until the piston element 46 almost abuts the partitions 48. The linear actuator is thus a closed system, meaning that the same fluid is recirculated by being pumped back and forth in the piston housing 47 in order to move the one or more piston element 46 back and forth.

[0037] In another embodiment the linear actuator may comprise an electric linear motor 51 driving the stoker shaft 45.

[0038] Fig. 3a shows a plug device 3 adapted to be arranged in continuation of the pump section, as shown in Fig. 1. The plug device is adapted for anchoring the wireline pumping assembly in the well and for providing a circumferential seal in an annulus 62 between the wire-

line pumping assembly and the casing 61 (shown in Fig. 5a) or an inside wall of the well. The plug device comprises a base part 31 having a through-going bore 32 extending in a longitudinal direction and a plurality of sealing elements 34 disposed around the base part for sealing off the annulus. Above the sealing elements 34, a compression sleeve 38 and an anchor mechanism 33 are slidably disposed around the base part. The anchor mechanism comprises a plurality of setting slips 331 which are adapted to extend from the base part in a substantially radial direction. When the plug device is coupled to the pump section, the bore 32 of the plug device is in fluid communication with the inlet 21 of the pump section. Well fluid may thus be sucked into the pump chamber 201 via the bore 32.

[0039] To set or activate the plug device, a force is applied to the anchor mechanism 33 in the longitudinal direction, thereby displacing the anchor mechanism towards the sealing elements. As the anchor mechanism is displaced, the setting slips 331 engage a cone-shaped section 381 of compression sleeve facing towards the anchor mechanism. The cone-shape of the compression sleeve forces the setting slips in an outwards radial direction for engagement with the casing when the wireline pumping assembly is positioned downhole. As the compression sleeve is also slidably disposed around the base part 31, displacement of the anchor mechanism 33 displaces the compression sleeve in the same direction towards the sealing elements. The sealing elements 34 are adapted to extend from the base part 31 to seal off the annulus when the compression sleeve is displaced. Displacement of the compression sleeve applies a compression force to the sealing elements 34, whereby the sealing elements are compressed in the longitudinal direction, resulting in the sealing elements buckling outwards. The cooperation relationship of the anchor mechanism, the compression sleeve 38 and the sealing elements 34 thus results in the setting slips 331 and the sealing elements 34 being simultaneously extended from the base part 31 to set the plug device.

[0040] In one embodiment, the wireline pumping assembly may further comprise an equalisation valve 37, as shown in Fig. 3b. The equalisation valve is adapted to control the flow through the bore 32 of the plug device 3. The equalisation valve may also be used for equalising a differential pressure created across the plug device when the plug device is set in the well and well fluid is pumped from the lower sealed-off section 66a of the well below the plug to the upper section 66b of the well above the sealing elements, as shown in Figs. 5a and 5b. As shown in Fig. 3b, the equalisation valve is provided in the bore 32 of the plug. However, if the plug device is an integrated part of the wireline pumping assembly, the equalisation valve may also be incorporated in the pumping section (not shown). To monitor and measure the differential pressure across the plug device, the plug device or other parts of the wireline pumping assembly may comprise a system for measuring the differential pres-

sure, such as one or more sensors 39 for measuring the pressure in the lower and the upper section of the well. The differential pressure may, however, also be determined based on other principles known to the skilled person, inter alia based on the force required to drive the plunger in the pump section.

[0041] Further, when the differential is negative, i.e. when the pressure in the lower sealed-off section 66a of the well below the set sealing element is higher than the pressure in the upper section 66b of the well, the well may start flowing by itself as the well fluid flows from regions with higher pressure towards regions with lower pressure. In the embodiment of the pump section shown in Fig. 2, the design of the first valve 22 and the second valve 24 allows well fluid to flow from the inlet 21 towards the outlets 27 regardless of the position of the plunger 23. Hereby, the wireline pumping assembly 1 operates in a contributory way by boosting the existing flow in the well.

[0042] Based on the flow through the plug device 3 and/or the flow through the pump section 2, the differential pressure may also be measured by a single sensor arranged across the plug device or by a single sensor in the plunger conducting measurements over time. An alternative method for determining the differential pressure is to measure the flow through the outlets 27 of the pump section., e.g. by providing a flow meter 28 in one or more of the outlets 27.

[0043] In Fig. 6 the wireline pumping assembly is provided with a driving unit 9 and an anchoring section 8. The driving section is adapted to drive the wireline pumping assembly forward in inclined sections of the well, and the anchoring section may be used for fixating the wireline pumping assembly downhole.

[0044] The wireline pumping assembly may be used for various purposes requiring pumping downhole. In particular, the wireline pumping assembly may be used for initiation of a well that has been intentionally killed, e.g. to perform maintenance operations or the like downhole. To kill a well, water may be introduced into the well, thereby increasing the hydrostatic pressure preventing hydrocarbon from being forced to the surface by the pressure exerted by the surrounding formation. Such a well may be initiated by subsequently removing the water from the well. To do so, a wireline pumping assembly according to the present invention is introduced into a well through the lubricator (not shown) at the surface of the well.

[0045] Figs. 5a and 5b show the wireline pumping assembly being submerged in a well 65 via a wireline 60. When the wireline pumping assembly 1 has reached the specified position, the plug device is activated, whereby the setting slips 331 engage the casing 61 to fixate the wireline pumping assembly, and the sealing elements 34 are simultaneously extended to provide a circumferential seal sealing off the annulus. When the wireline pumping assembly has been set, the well is thus divided into a lower sealed-off section 66a of the well below the set

sealing elements and an upper section 66b of the well above the set sealing elements.

[0046] Next, the pumping section 2 is activated to pump well fluid from below the set sealing elements 34 to the upper section 66b of the well. Pumping well fluid from the lower sealed-off section 66a to the upper section of the well results in lifting of the well fluid in the upper section towards the surface and in a pressure built up in the lower section of the well. The pressure in the upper and/or the lower section is continuously monitored to be able to determine when enough water has been removed for the well to be able to run by itself. When the desired pressure in the lower sealed-off section 66a has been reached, the operation of the pumping section may be stopped.

[0047] Before the wireline pumping assembly can be removed, the pressure across the plug device has to be equalised, which may be done by operating the equalisation valve provided in the plug device or in another part of the wireline pumping assembly. When the pressure has been equalised, the wireline pumping assembly is pulled up into the lubricator and subsequently removed from the well. Subsequently, the wireline pumping assembly may easily be moved to the next well to perform as similar initiation operation.

[0048] In another embodiment, the plug device 3 and the remainder of the wireline pumping assembly 1 may be separately operated and adapted to be releasably connected downhole. In that case, first the plug device is inserted into the well and set in the desired position by activating the anchoring mechanism and the sealing elements. Subsequently, the wireline pumping assembly is introduced into the well and connected with the plug device. When the desired pressure in the lower sealed-off section 66a has been reached by operating the pumping section, the wireline pumping assembly may be removed from the well. Subsequently, the pressure may be equalised using the equalisation valve provided in the plug device, and the plug device may be removed.

[0049] Additionally, the design of the plug device 3 and the remainder of the wireline pumping assembly 1 as separate and releasably connectable units may allow for the plug device 3 to be arranged in the well downhole permanently or for longer periods of time.

[0050] Further, as described above, the design of the pump section allows well fluid to flow from the inlet 21 towards the outlets 27 regardless of the position of the plunger 23. The wireline pump assembly may thus be arranged in the well downhole permanently or for longer periods of time, operating based on the actual demand for boosting the flow in the well. If for some reason the flow in the well suddenly drops, the wireline pump assembly may be activated to boost the flow until the well is once again able to run by itself. The wireline pump assembly may be activated either automatically based on a measured pressure in the well or by a signal received from an operator. The measured differential pressure across the set sealing elements may thus be used to

control the operation of the pumping action of the wireline pumping assembly by continuously activating and deactivating the pumping action to boost the flow in the well.

[0051] By fluid or well fluid is meant any kind of fluid that may be present in oil or gas wells downhole, such as natural gas, oil, oil mud, crude oil, water, etc. By gas is meant any kind of gas composition present in a well, completion, or open hole, and by oil is meant any kind of oil composition, such as crude oil, an oil-containing fluid, etc. Gas, oil, and water fluids may thus all comprise other elements or substances than gas, oil, and/or water, respectively.

[0052] By a casing is meant any kind of pipe, tubing, tubular, liner, string etc. used downhole in relation to oil or natural gas production.

[0053] In the event that the assembly is not submergible all the way into the casing, a downhole tractor can be used to push the assembly all the way into position in the well. The downhole tractor may have projectable arms having wheels, wherein the wheels contact the inner surface of the casing for propelling the tractor and the assembly forward in the casing. A downhole tractor is any kind of driving tool capable of pushing or pulling tools in a well downhole, such as a Well Tractor®.

[0054] Also, the linear actuator may be a Well Stroker®. Although the invention has been described in the above in connection with preferred embodiments of the invention, it will be evident for a person skilled in the art that several modifications are conceivable without departing from the invention as defined by the following claims.

Claims

1. A wireline pumping assembly (1) for being introduced in a wellbore (60) or a casing (61) and submerged in well fluid, the wireline pumping assembly extending in a longitudinal direction (50) and being adapted for connection with a wireline (60), and the wireline pumping assembly comprising a pump section (2) comprising:

- a tubular pump housing (20) providing a pump chamber (210),
- one or more inlets (21) provided in a lower part of the tubular pump housing,
- a first valve (22) for opening and closing the inlet,
- a plunger (23) being slidably disposed in the pump chamber, the plunger comprising a second valve (242) controlling a flow of fluid from a first compartment (202) of the pump chamber on one side of the plunger to a second compartment (203) of the pump chamber on the other side of the plunger,
- a pump rod () operably connected to the plunger and extending from the plunger through the

- tubular pump housing, and
 - one or more outlets (27) provided in an upper part of the tubular pump housing, wherein the wireline pumping assembly further comprises:
- a linear actuator (40) arranged in association with the tubular pump housing for driving the pump rod, whereby, when the wireline pumping assembly is at least partially submerged into the well fluid, well fluid is drawn into the tubular pump housing through the one more inlets, forced through the second valve of the plunger, and expelled through the one or more outlets in the upper part of the tubular pump housing.
2. A wireline pumping assembly (1) according to claim 1, wherein the linear actuator comprises:
- a tubular stoker cylinder (4) comprising one or more piston housings (47),
 - one or more piston elements (46) slidingly disposed in the piston housing to divide the piston housing into a first chamber (41) and a second chamber (42),
 - a stoker shaft (45) operably connected to the piston element and for connection with the pump rod to provide reciprocation of the plunger,
 - a pump (5) for alternately supplying hydraulic fluid under pressure to the first chamber and the second chamber of the tubular stoker cylinder to reciprocate the piston element in the tubular stoker cylinder, and
 - an electrical motor (6) for driving the pump.
3. A wireline pumping assembly (1) according to claim 2, wherein the linear actuator comprises a plurality of piston elements (46) slidingly disposed in a plurality of piston housings 47 and operably connected to the stoker shaft.
4. A wireline pumping assembly (1) according to claim 1, wherein the linear actuator comprises:
- an electric linear motor (51), and
 - a stoker shaft (45) driven by the electric linear motor for connection with the pump rod to provide reciprocation of the plunger,
5. A wireline pumping assembly (1) according to any of the preceding claims, further comprising a plug device (3) for providing a seal in an annulus (62) between the wireline pumping assembly and the casing, the plug device comprising:
- a base part (31) connected with the tubular pump housing and having a through-going bore (32), and
 - one or more sealing elements (34) disposed
- around the base part, extendable from the base part for sealing off the annulus.
6. A wireline pumping assembly (1) according to claim 5, wherein the plug device further comprises an anchor mechanism (33) for fixating the wireline pumping assembly in the well, the anchor mechanism being slidingly disposed around the base part and comprising a plurality of setting slips (331) extendable from the base part in a substantial radial direction for engagement with the casing.
7. A wireline pumping assembly (1) according to claim 5 or 6, wherein the plug device further comprises a compression sleeve (38) slidingly disposed around the base part for compressing the one or more sealing elements, and wherein the sealing elements are adapted to extend from the base part to seal off the annulus when the compression sleeve is displaced in the longitudinal direction towards the one or more sealing elements, thereby applying a compression force to the one or more sealing elements.
8. A wireline pumping assembly (1) according to claim 7, wherein the compression sleeve comprises a cone-shaped section (381) facing towards the anchor mechanism, the cone-shaped section being adapted to force the setting slips in a radial direction, at least upon activation of the anchor mechanism, when the plurality of setting slips are displaced towards the compression sleeve thereby engaging the cone-shaped section.
9. A wireline pumping assembly (1) according to any of the claims 5-8, further comprising an equalisation valve (37) for equalising a differential pressure across the plug, at least prior to disengaging of the plug, when the plug device is set in a well.
10. A wireline pumping assembly (1) according to any of the claims 5-9, further comprising one or more sensors (39) for measuring a differential pressure across the plug device when the plug device is set in a well.
11. A wireline pumping assembly (1) according to any of the preceding claims, further comprising an anchor section (8) for anchoring the wireline pumping assembly in the well, the anchor section comprising a plurality of hydraulic activatable anchoring elements (81) extendable from the tool body, for engagement with the casing.
12. A wireline pumping system (10) comprising a wireline pumping assembly (1) according to any of the claims 1-4, and a plug device (3) for providing a seal in an annulus (62) between the plug device and the casing, the plug device comprising:

- a base part (31) having a through-going bore (32) adapted to be connected with the tubular pump housing of the pump section, and
 - one or more sealing elements (34) disposed around the base part, extendable from the base part for sealing off the annulus, wherein, the wireline pumping assembly being adapted for connection with the plug device downhole following setting of the plug device in the well. 5 10
- 13.** Use of the wireline pumping assembly according to any of the claims 1-11 or a wireline pumping system according to claim 12 for initiation of a killed well by removing water present in the well using the pumping action provided by the pumping assembly. 15
- 14.** A method of initiating a well using a wireline pumping assembly according to any of the claims 1-11, comprising the step of: 20
- inserting the wireline pumping assembly into the wellbore,
 - setting a plug device for providing a seal in an annulus (62) between the plug device and the casing, the plug device comprising: 25
- a base part (31) having a through-going bore (32) adapted to be connected with the tubular pump housing of the pump section, and 30
 - one or more sealing elements (34) disposed around the base part, extendable from the base part for sealing off the annulus, 35
- operating the pumping section of the wireline pumping assembly to pump fluid past the plug device until a pressure below the plug device is sufficient to make the well run by itself, 40
 - equalising the pressure over the plug by operating the equalisation valve, and
 - removing the wireline pumping assembly from the well. 45
- 15.** A method of optimising an initiation operation, comprising the step of:
- determining a pressure level in the well below the plug device, sufficient to make the well run by itself, 50
 - continuously monitoring the pressure in the well below the plug device while the pumping section is operated to pump fluid from below the plug device to above the plug device, and 55
 - determining when the predetermined pressure level is reached, following which the operation of the pumping section may be stopped.

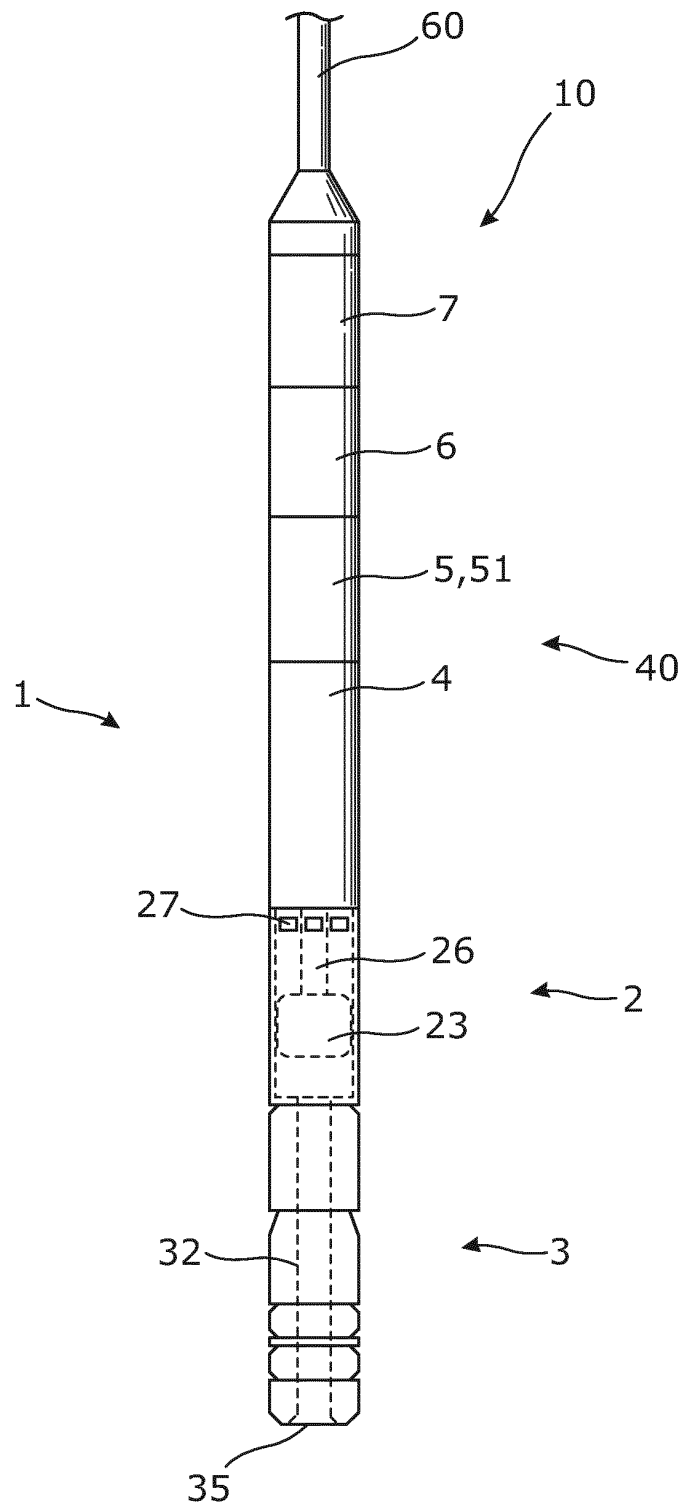

Fig. 1

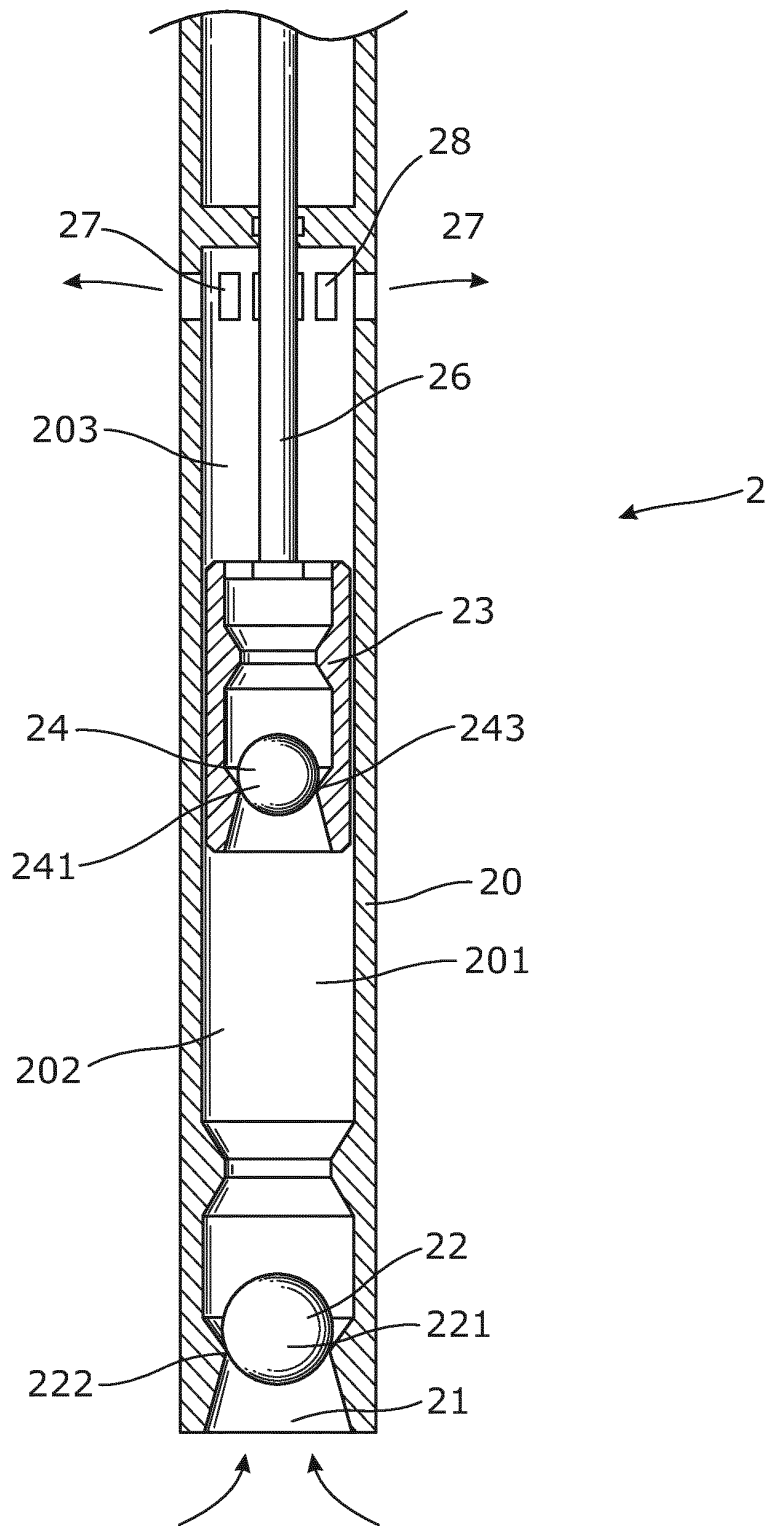

Fig. 2

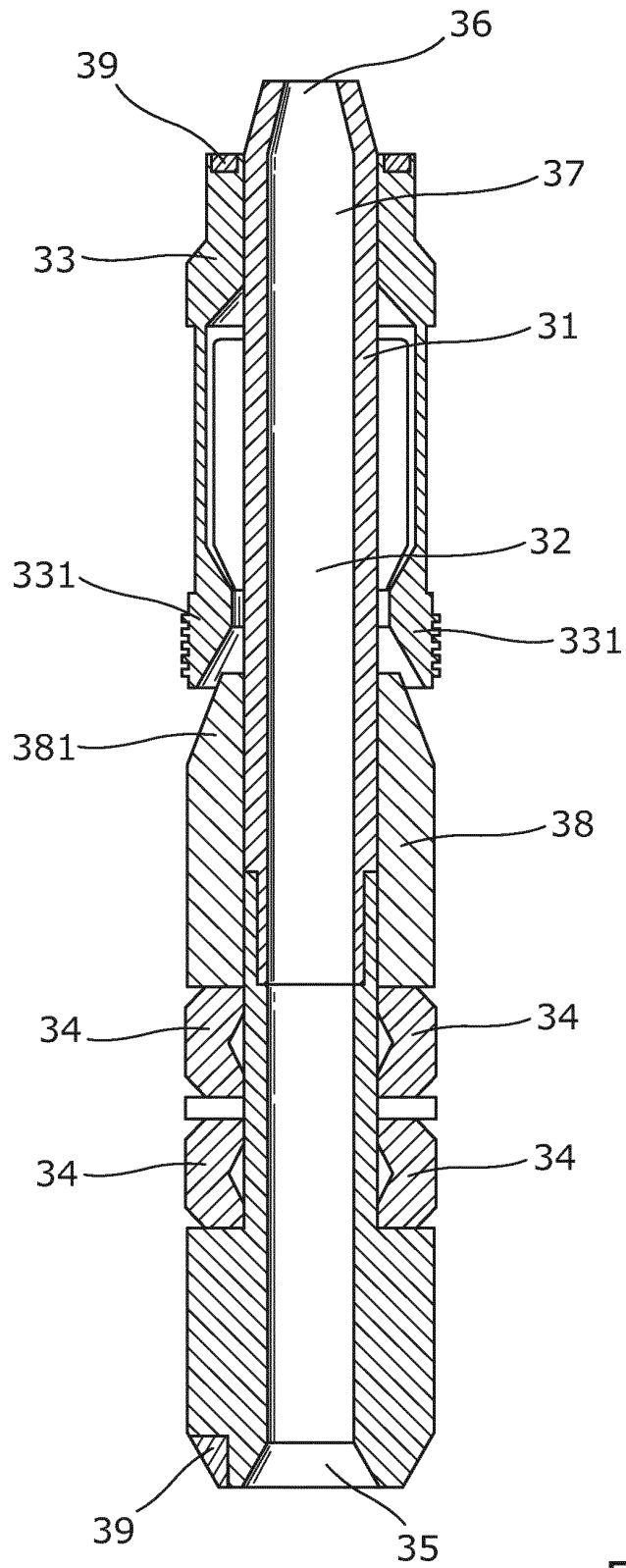

Fig. 3a

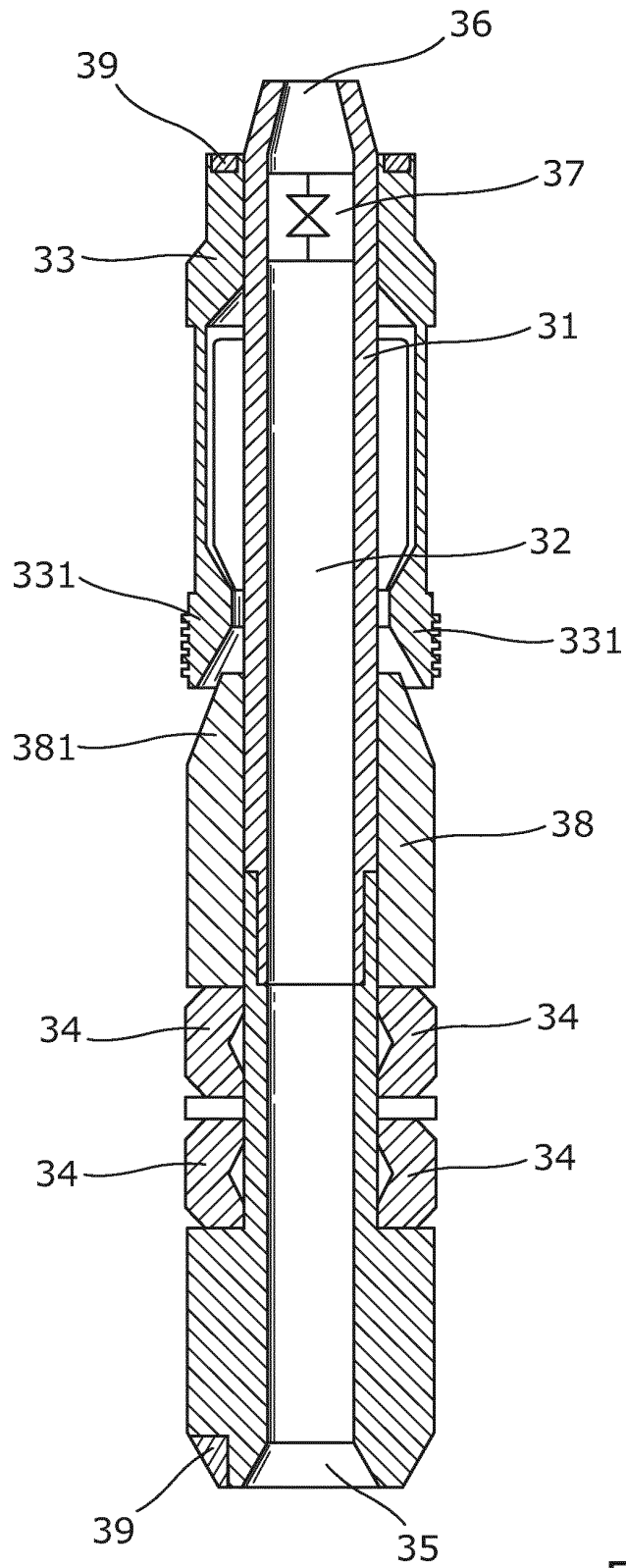

Fig. 3b

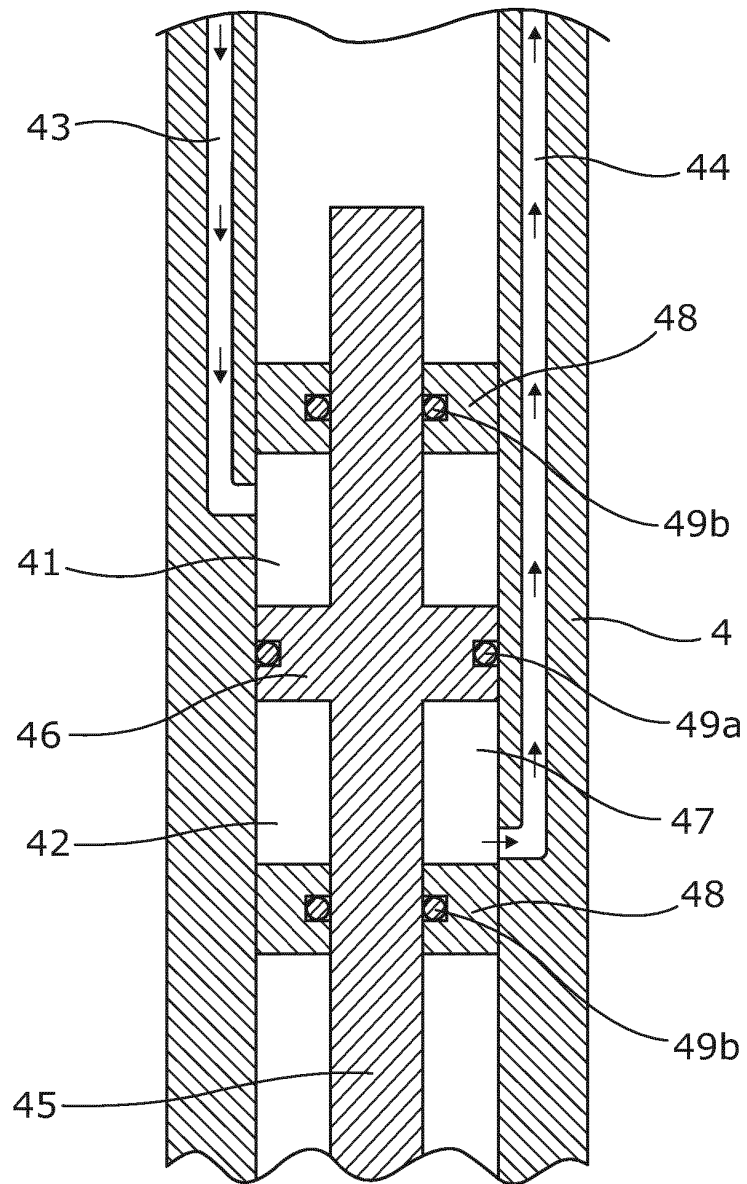

Fig. 4a

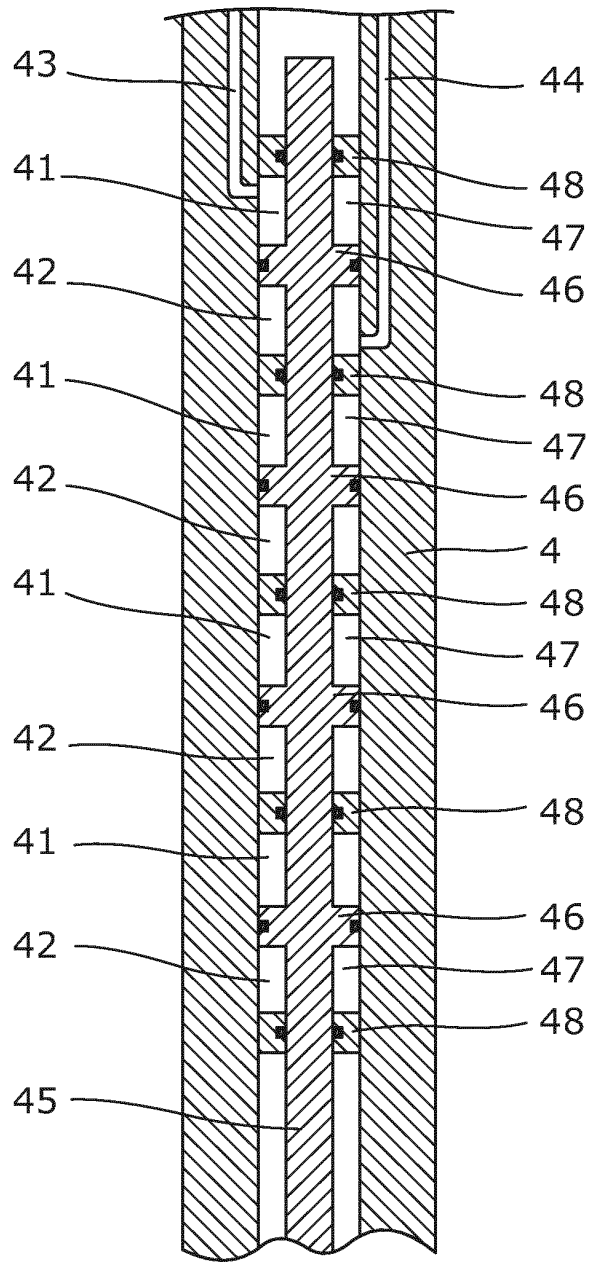

Fig. 4b

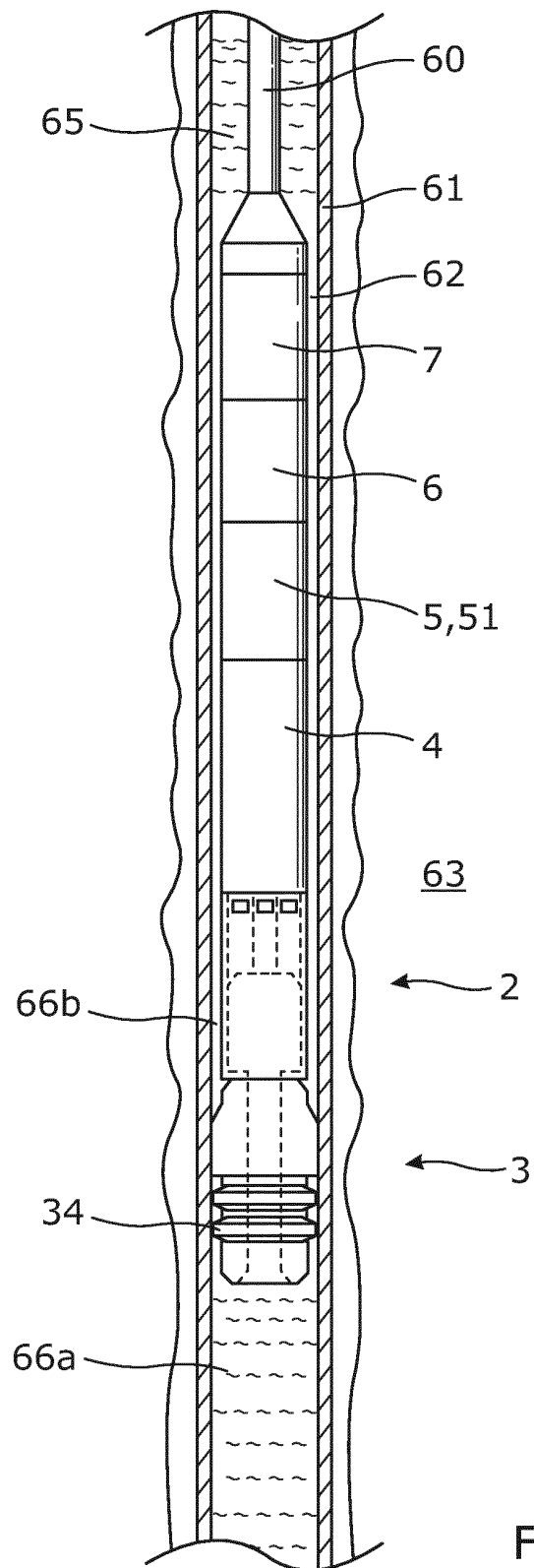

Fig. 5a

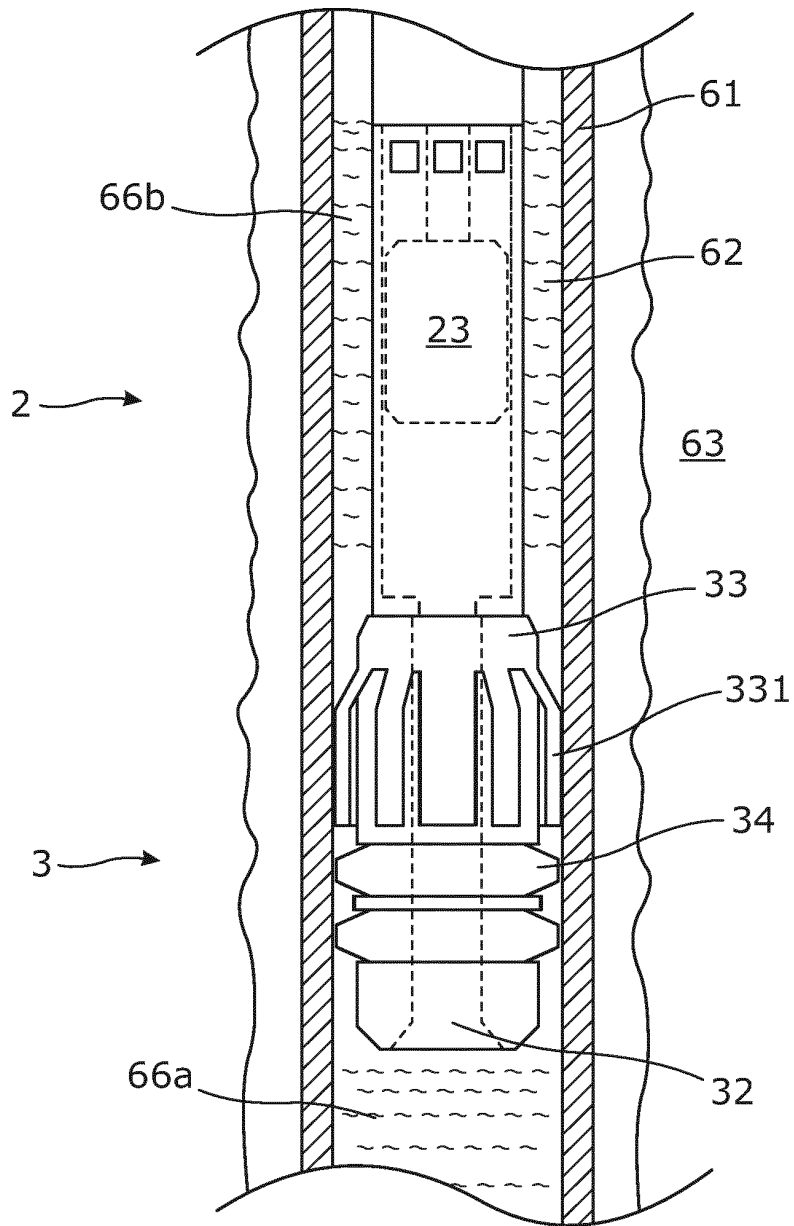

Fig. 5b

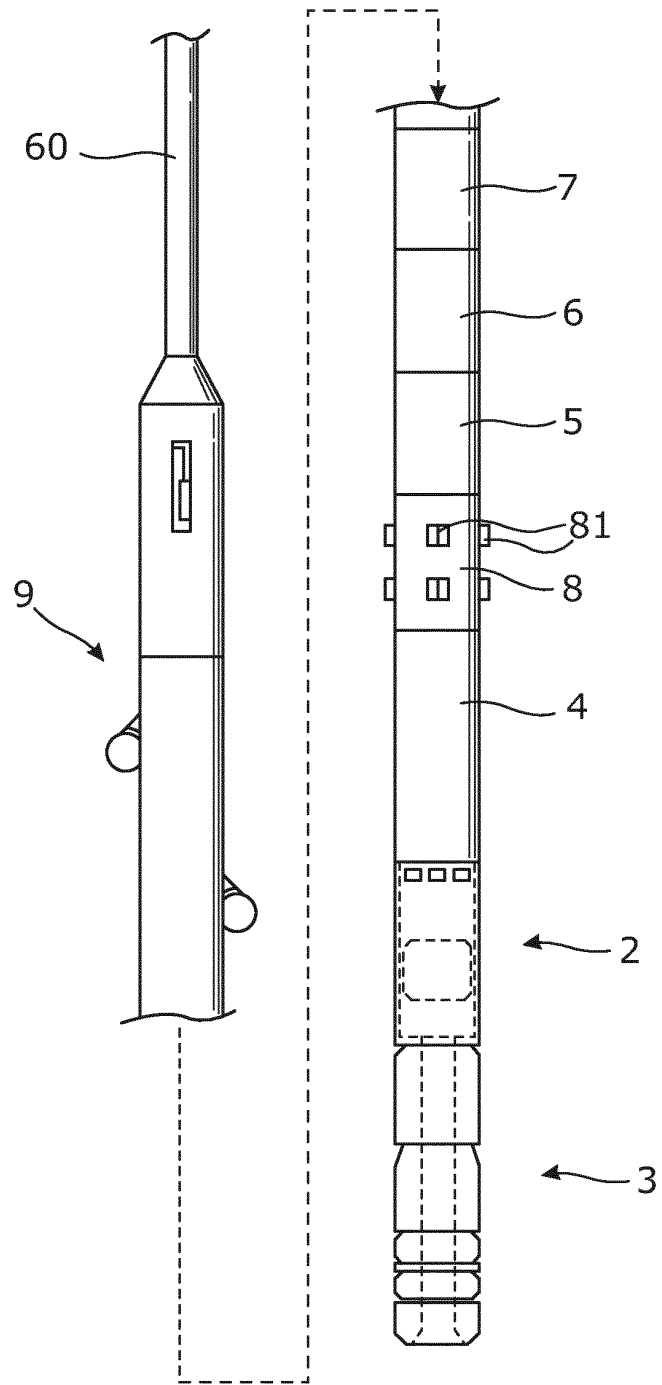

Fig. 6



EUROPEAN SEARCH REPORT

Application Number
EP 12 19 0177

DOCUMENTS CONSIDERED TO BE RELEVANT			
Category	Citation of document with indication, where appropriate, of relevant passages	Relevant to claim	CLASSIFICATION OF THE APPLICATION (IPC)
X	WO 93/06369 A1 (UNIFLO OILCORP LTD [US]) 1 April 1993 (1993-04-01)	1,4	INV. E21B43/12 F04B9/103 F04B47/08 F04B47/12
Y	* abstract; figure 15 *	2,3,5-15	
Y	GB 2 442 610 A (WEATHERFORD LAMB [US]) 9 April 2008 (2008-04-09) * page 5, line 13 - line 27 *	3,5-15	
Y	US 5 411 381 A (PERRODIN PHILIP E [US]) 2 May 1995 (1995-05-02) * the whole document *	2	
A	WO 2006/063562 A1 (DIETRICH HERWART [DE]; LOEBER KLAUS-JUERGEN [DE]) 22 June 2006 (2006-06-22) * the whole document *	1	
			TECHNICAL FIELDS SEARCHED (IPC)
			E21B F04B
The present search report has been drawn up for all claims			
Place of search Munich		Date of completion of the search 13 March 2013	Examiner Ott, Stéphane
CATEGORY OF CITED DOCUMENTS X : particularly relevant if taken alone Y : particularly relevant if combined with another document of the same category A : technological background O : non-written disclosure P : intermediate document		T : theory or principle underlying the invention E : earlier patent document, but published on, or after the filing date D : document cited in the application L : document cited for other reasons & : member of the same patent family, corresponding document	

1
EPO FORM 1503 03.82 (P04G01)

**ANNEX TO THE EUROPEAN SEARCH REPORT
ON EUROPEAN PATENT APPLICATION NO.**

EP 12 19 0177

This annex lists the patent family members relating to the patent documents cited in the above-mentioned European search report. The members are as contained in the European Patent Office EDP file on
The European Patent Office is in no way liable for these particulars which are merely given for the purpose of information.

13-03-2013

Patent document cited in search report	Publication date	Patent family member(s)	Publication date
WO 9306369 A1	01-04-1993	AU 2594792 A US 5252043 A WO 9306369 A1	27-04-1993 12-10-1993 01-04-1993
GB 2442610 A	09-04-2008	NONE	
US 5411381 A	02-05-1995	NONE	
WO 2006063562 A1	22-06-2006	DE 102004060324 A1 WO 2006063562 A1	14-06-2006 22-06-2006

EPO FORM P0489

For more details about this annex : see Official Journal of the European Patent Office, No. 12/82