



(11) **EP 2 743 504 B1**

(12) **EUROPEAN PATENT SPECIFICATION**

(45) Date of publication and mention of the grant of the patent:
18.11.2015 Bulletin 2015/47

(51) Int Cl.:
F04B 27/18^(2006.01)

(21) Application number: **13196256.5**

(22) Date of filing: **09.12.2013**

(54) **Control valve for variable displacement compressor**

Regelventil für einen Verdichter mit variabler Verdrängung

Soupape de contrôle pour compresseur de déplacement variable

(84) Designated Contracting States:
AL AT BE BG CH CY CZ DE DK EE ES FI FR GB GR HR HU IE IS IT LI LT LU LV MC MK MT NL NO PL PT RO RS SE SI SK SM TR

(30) Priority: **11.12.2012 JP 2012270291**

(43) Date of publication of application:
18.06.2014 Bulletin 2014/25

(60) Divisional application:
15153880.8 / 2 916 003
15153882.4 / 2 918 833

(73) Proprietor: **TGK CO., Ltd.**
Tokyo 193-0942 (JP)

(72) Inventors:
• **Tonegawa, Masaaki**
Tokyo, 193-0942 (JP)
• **Sakakibara, Hidekazu**
Tokyo, 193-0942 (JP)
• **Sugamura, Ryouta**
Tokyo, 193-0942 (JP)
• **Saeki, Shinji**
Tokyo, 193-0942 (JP)

(74) Representative: **Schröer, Gernot H.**
Meissner, Bolte & Partner GbR
Bankgasse 3
90402 Nürnberg (DE)

(56) References cited:
EP-A1- 1 512 871 EP-A1- 2 090 779
JP-A- 2008 240 580

EP 2 743 504 B1

Note: Within nine months of the publication of the mention of the grant of the European patent in the European Patent Bulletin, any person may give notice to the European Patent Office of opposition to that patent, in accordance with the Implementing Regulations. Notice of opposition shall not be deemed to have been filed until the opposition fee has been paid. (Art. 99(1) European Patent Convention).

Description

[0001] The present invention relates to a control valve that is suitable for controlling the discharging capacity of a variable displacement compressor.

[0002] An automotive air conditioner generally includes a compressor, a condenser, an expander, an evaporator, and so forth. Here, the compressor discharges a high-temperature and high-pressure gaseous refrigerant produced by compressing a refrigerant flowing through a refrigeration cycle of a vehicle. The condenser condenses the gaseous refrigerant. The expander produces a low-temperature and low-pressure refrigerant by adiabatically expanding the condensed liquid refrigerant. The evaporator evaporates the refrigerant and thereby causes a heat exchange of the refrigerant with air inside a vehicle's compartment. The refrigerant evaporated by the evaporator is again brought back to the compressor and thus circulates through the refrigeration cycle.

[0003] The compressor is, for example, a variable displacement compressor (hereinafter referred to simply as "compressor" also) capable of varying the refrigerant discharging capacity in order to maintain a constant level of cooling capacity irrespective of the engine speed. This compressor has a piston for compression linked to a wobble plate that is mounted to a rotational shaft driven by an engine, and the compressor regulates the refrigerant discharge rate by changing the stroke of the piston through changes in the angle of the wobble plate. The angle of the wobble plate can be changed continuously by changing the balance of pressure working on both faces of the piston as part of the discharged refrigerant is introduced into an airtight crankcase. The pressure within this crankcase (hereinafter referred to as "crank pressure") P_c is controlled by a control valve for a variable displacement compressor (hereinafter referred to simply as "control valve" also), which is provided between the discharge chamber and the crankcase of the compressor.

[0004] Such a control valve regulates the valve opening degree by supplying the externally applied current to a solenoid, which functions as a driver part. Suppose that an air conditioning function needs to be quickly fulfilled at the startup or the like of the air conditioner. Then, a valve section is set to a closed state by supplying the maximum current to the solenoid, for instance. Also, the wobble plate is tilt relative to the rotational shaft for a large angle by lowering a crank pressure P_c . As a result, the compressor can be operated at the maximum capacity. When the engine load of a vehicle is high, the compressor can be operated at the minimum capacity by fully opening the valve section with the solenoid turned off and by setting the wobble plate substantially at a right angle to the rotational shaft with the crank pressure P_c set high.

[0005] The control valve like this is disclosed in Reference (1) in the following Related Art List, for instance.

That is, the control valve is provided with a main valve in a main passage that communicates the discharge chamber with the crankcase and also a sub-valve in a sub-passage that communicates the crankcase with a suction chamber. And the main valve and the sub-valve are driven by a single solenoid. During a steady operation, this control valve regulates the opening degree of the main valve with the sub-valve closed. Thereby, the crank pressure P_c can be controlled and the discharging capacity can also be controlled as described above. On the other hand, at a power-on of the air conditioner, the sub-valve is open with the main valve closed. Thereby, the crank pressure P_c is quickly lowered. As a result, the compressor can promptly shift its operation mode to a maximum-capacity operation. Also, a plurality of valves are opened and closed by the use of a single solenoid. Thus, the control valve can be of a reduced size as a whole.

[0006] In such a control valve as described above, the main valve and sub-valve are driven by the single solenoid. Thus, a main valve element and a sub-valve element are provided along the same axis line, and the control valve has a mechanism that transports the solenoidal force to the each valve element by way of an actuating rod provided along said axis line. The body of the control valve has a main valve hole, and the main valve element has a sub-valve hole. That is, the sub-passage runs through the main valve element. The main valve element touches and leaves a main valve seat, provided in an opening end of the main valve hole, so as to close and open the main valve, respectively. And the sub-valve element touches and leaves a sub-valve seat, provided in an opening end of the sub-valve hole, so as to close and open the sub-valve, respectively. Since, however, the sub-valve is pressed against the sub-valve seat by the biasing force of a spring during a steady operation of the compressor, the sub-valve is kept closed. At the startup of the compressor, the solenoidal force is at its maximum and the sub-valve element is further biased in a valve opening direction while the main valve element is seated on the main valve seat. This opens the sub-valve.

Related Art List

[0007]

(1) Japanese Unexamined Patent Application Publication (Kokai) No. 2008-240580.

[0008] In recent years, vehicle makers demand that the compressor be started more promptly. Providing more quick air condition performance is advantageous in pursuit of increased vehicle comfort and eventually achieves the sale promotions of such vehicles. In order to achieve this, the flow rate of refrigerant at the time the sub-valve is open needs to be made larger. Since, however, the aforementioned control valve is configured such that the sub-valve hole is formed in the main valve element, the size of the sub-valve is constrained by the size

of the main valve and therefore it is not easy to obtain a desired flow rate thereof. In other words, it is not physically possible to make the sub-valve hole larger than the main valve hole. In the light of this fact, it may be conceivable that an uplift amount of the sub-valve element from the sub-valve seat is set larger. However, an increase in stroke of the sub-valve element entails an increase in the overall size of the control valve, thus being disadvantageous in terms of cost. Even if the stroke thereof is increased, the flow rate cannot be increased significantly unless the size of the sub-valve hole is changed.

[0009] The present invention has been made in view of the foregoing problems, and a purpose thereof is to obtain a large flow rate of refrigerant, at the time the sub-valve is open, in a control valve where a main valve and a sub-valve are driven by a single solenoid.

[0010] In accordance with claim 1, there is provided a control valve for a variable displacement compressor for varying a discharging capacity of the compressor for compressing refrigerant led into a suction chamber and discharging the compressed refrigerant from a discharge chamber, by regulating a flow rate or pressure of at least one of the refrigerant led into a crankcase from the discharge chamber and the refrigerant led out to the suction chamber from the crankcase. The control valve comprises:

a body having a main passage, which communicates between the discharge chamber and the crank case, and a sub-passage, which communicates between the crankcase and the suction chamber;
 a main valve seat provided in the main passage;
 a main valve element configured to open and close a main valve by touching and leaving the main valve seat;
 a sub-valve seat provided in the sub-passage;
 a sub-valve element configured to open and close a sub-valve by touching and leaving the sub-valve seat ;
 a pressure-sensing section configured to sense a predetermined pressure-to-be-sensed and configured to generate a drive force exerted in an opening direction of the main valve in accordance with a magnitude of the pressure-to-be-sensed;
 a solenoid configured to generate a drive force in a closing direction of the main valve in accordance with an amount of current supplied; and
 a valve-opening mechanism configured to open the sub-valve by using a drive force of the solenoid, wherein the pressure-sensing section, the main valve, the sub-valve, and the solenoid are arranged in this order from one end side of the body, wherein the sub-valve element is arranged such that the sub-valve is opened on a side closer to the solenoid than the main valve

[0011] In accordance with claim 3, there is provided a

control valve for a variable displacement compressor for varying a discharging capacity of the compressor for compressing refrigerant led into a suction chamber and discharging the compressed refrigerant from a discharge chamber, by regulating a flow rate or pressure of at least one of the refrigerant led into a crankcase from the discharge chamber and the refrigerant led out to the suction chamber from the crankcase. The control valve comprising:

a body having a main passage, which communicates between the discharge chamber and the crank case, and a sub-passage, which communicates between the crankcase and the suction chamber;

a main valve seat provided in the main passage;

a main valve element configured to open and close a main valve by touching and leaving the main valve seat;

a sub-valve seat provided in the sub-passage;

a sub-valve element configured to open and close a sub-valve by touching and leaving the sub-valve seat;

a pressure-sensing section configured to sense a predetermined pressure-to-be-sensed and configured to generate a drive force exerted in an opening direction of the main valve in accordance with a magnitude of the pressure-to-be-sensed;

a solenoid configured to generate a drive force in a closing direction of the main valve in accordance with an amount of current supplied; and

a valve-opening mechanism configured to open the sub-valve by using a drive force of the solenoid, wherein the pressure-sensing section, the main valve, the sub-valve, and the solenoid are arranged in this order from one end side of the body, the control valve further comprising:

an actuating rod configured to transmit the drive forces of the pressure-sensing section and the solenoid to the main valve and the sub-valve, the actuating rod being disposed between the pressure-sensing section and the solenoid,

wherein the valve-opening mechanism is a mechanism where after the main valve has been closed, the sub-valve is opened by moving the actuating rod and

wherein the control valve further comprising:

the sub-valve seat provided in a part of body;

a valve seat forming section configured to be slidably supported by the body, the valve seat forming section being formed integrally with the main valve seat; and

the main valve element configured to close and open the main valve by touching and leaving the main valve seat (22), respectively, the main valve element being formed integrally and freely movable with the actuating rod

wherein the valve-opening mechanism is con-

figured to open the sub-valve in a manner such that

the main valve element is seated on the main valve seat by moving the actuating rod, and the sub-valve element is separated away from the sub-valve seat, by pressing and displacing the valve seat forming section via the main valve element.

[0012] In order to resolve the aforementioned problems, a control valve for a variable displacement according to one embodiment of the present invention varies a discharging capacity of the compressor for compressing refrigerant led into a suction chamber and discharging the compressed refrigerant from a discharge chamber, by regulating a flow rate or pressure of at least one of the refrigerant led into a crankcase from the discharge chamber and the refrigerant led out to the suction chamber from the crankcase, and the control valve includes: a body having a main passage, which communicates between the discharge chamber and the crank case, and a sub-valve passage, which communicates between the crankcase and the suction chamber; a main valve seat provided in the main passage; a main valve element configured to open and close a main valve by touching and leaving the main valve seat; a sub-valve seat provided in the sub-valve passage; a sub-valve element configured to open and close a sub-valve by touching and leaving the sub-valve seat; a pressure-sensing section configured to sense a predetermined pressure-to-be sensed and configured to generate a drive force in an opening direction of the main valve in accordance with a magnitude of the pressure-to-be-sensed; and a solenoid configured to generate a drive force in a closing direction of the main valve in accordance with an amount of current supplied. The pressure-sensing section, the main valve, the sub-valve, and the solenoid are arranged in this order from one end side of the body, and the control valve further includes a valve-opening mechanism configured to open the sub-valve by using a drive force of the solenoid.

[0013] Such a control valve as described in the above embodiment is configured such that the control valve is assembled by inserting it into a mounting hole of the variable displacement compressor. Thus, in consideration of easiness to insert it thereinto, the control valve is basically of a structure such that the outside diameter thereof becomes smaller toward a tip end side starting from a rear end side in an insertion direction. In other words, the outside diameter thereof becomes smaller toward a pressure-sensing section side from a solenoid side, and, in this embodiment, the pressure-sensing section, the main valve, the sub-valve, and the solenoid are arranged in this order from one end side of the body, and the sub-valve is provided on a side closer to the solenoid where the outside diameter of the body is larger. This arrangement allows the sub-valve to be placed in a relatively large space. That is, by employing this embodiment, the sub-valve can be made larger independently of the main

valve and therefore a large flow rate of refrigerant can be obtained at the time the sub-valve is open.

[0014] Another embodiment of the present invention relates also to a control valve. The control valve includes a body having a lead-in/out port through which a working fluid is led in or led out, a lead-in port through which the working fluid is led in, and a lead-out port through which the working fluid is led out; a main valve provided in a main passage, which communicates between the lead-in port and the lead-in/out port; a sub-valve provided in a sub-passage, which communicates between the lead-in/out port and the lead-out port; a pressure-sensing section configured to sense a predetermined pressure-to-be sensed and configured to exert a drive force exerted in an opening direction of the main valve in accordance with a magnitude of the pressure-to-be-sensed; and a solenoid configured to generate a drive force exerted in a closing direction of the main valve in accordance with an amount of current supplied. The pressure-sensing section, the main valve, the sub-valve, and the solenoid are arranged in this order from one end side of the body, and the control valve further includes a valve-opening mechanism configured to open the sub-valve by using a drive force of the solenoid.

[0015] In this embodiment, the pressure-sensing section, the main valve, the sub-valve, and the solenoid are arranged in this order from one end side of the body, and the sub-valve is provided on the side closer to the solenoid where the outside diameter of the body is larger. Accordingly, if the control valve according to this embodiment is configured such that it is inserted into an installation object or setting object, the sub-valve can be placed in a portion of the body where a relatively large space can be formed. That is, by employing this embodiment, the sub-valve can be made larger independently of the main valve and therefore a large flow rate of refrigerant can be obtained at the time the sub-valve is open.

[0016] Embodiments will now be described by way of examples only, with reference to the accompanying drawings which are meant to be exemplary, not limiting, and wherein like elements are numbered alike in several Figures in which:

FIG. 1 is a cross-sectional view showing a structure of a control valve according to a first embodiment; FIG. 2 is a partially enlarged cross-sectional view of the upper half of FIG. 1; FIG. 3 shows an operation of a control valve; FIG. 4 shows an operation of a control valve; FIG. 5 is a partially enlarged cross-sectional view of the upper half of a control valve according to a second embodiment; FIG. 6 is a partially enlarged cross-sectional view of the upper half of a control valve according to a third embodiment; and FIG. 7 is a partially enlarged cross-sectional view of the upper half of a control valve according to a fourth embodiment.

[0017] The invention will now be described based on preferred embodiments which do not intend to limit the scope of the present invention but exemplify the invention. All of the features and the combinations thereof described in the embodiment are not necessarily essential to the invention.

[0018] The present invention will now be described in detail based on preferred embodiments with reference to the accompanying drawings. In the following description, for convenience of description, the positional relationship in each structure may be expressed as "vertical" or "up-down" with reference to how each structure is depicted in Figures.

[First Embodiment]

[0019] FIG. 1 is a cross-sectional view showing a structure of a control valve according to a first embodiment. A control valve 1 is configured as an electromagnetic valve for controlling the discharging capacity of a not-shown variable displacement compressor (hereinafter referred to simply as "compressor") installed for a refrigeration cycle of an automotive air conditioner. This compressor discharges a high-temperature and high-pressure gaseous refrigerant produced by compressing a refrigerant flowing through the refrigeration cycle. The gaseous refrigerant is then condensed by a condenser (external heat exchanger) and further adiabatically expanded by an expander so as to become a misty, low-temperature and low-pressure refrigerant. This low-temperature and low-pressure refrigerant is evaporated by an evaporator, and the evaporative latent heat cools the air of an interior of a vehicle. The refrigerant evaporated by the evaporator is again brought back to the compressor and thus circulates through the refrigeration cycle. The compressor, which has a rotational shaft rotatingly driven by an engine of an automobile, is configured such that a piston for compression is linked to a wobble plate mounted to the rotational shaft. The compressor controls a refrigerant discharge rate by changing the stroke of the piston through changes in the angle of the wobble plate. The control valve 1 changes the angle of the wobble plate and consequently changes the discharging capacity of the compressor by controlling a flow rate of the refrigerant to be introduced from a discharge chamber to a crankcase of the compressor.

[0020] The control valve 1 is constituted as a so-called P_s sensing valve that controls the flow rate of refrigerant introduced from the discharge chamber to the crankcase so that a suction pressure P_s of the compressor can be maintained at a certain set pressure. Note here that the suction pressure P_s thereof corresponds to "pressure-to-be-sensed". The control valve 1 is constituted by integrally assembling a valve unit 2 and a solenoid 3. The valve unit 2 includes a main valve for opening and closing a refrigerant passage used to lead a part of the discharged refrigerant to the crankcase, during an operation of the compressor, and a sub-valve that functions as a

so-called bleed valve for releasing the refrigerant in the crankcase to a suction chamber, at a startup of the compressor. The solenoid 3 regulates the opening degree of the main valve by driving the main valve in a valve opening or closing direction, and controls the flow rate of refrigerant introduced into the crankcase. The valve unit 2 includes a body 5 of stepped cylindrical shape, a main valve and a sub-valve, which are provided inside the body 5, a power element 6, which generates a drive force against a solenoidal force to adjust the opening level of the main valve, and so forth. The power element 6 functions as a "pressure-sensing section".

[0021] The body 5 has ports 12, 14, 16, and 18 in this order from top down. Of these ports, the port 12 is provided in an upper-end opening of the body 5, and the ports 14, 16, and 18 are provided on a lateral side thereof. The ports 12 and 18 each functions as a "suction chamber communication port" that communicates with the suction chamber. The port 14 functions as a "discharge chamber communication port" that communicates with the discharge chamber. The port 16 functions as a "crankcase communication port" that communicates with the crankcase. An end member 13 is fixed to the upper-end opening of the body 5. A plurality of communicating grooves 15 are provided on the outer periphery of the end member 13. A lower end of the body 5 is coupled to an upper end of the solenoid 3.

[0022] A main passage, which communicates the port 14 with the port 16, and a sub-passage, which communicates the port 16 with the port 18 are formed inside the body 5. The main valve of small diameter is provided in the main passage, whereas the sub-passage of large diameter is provided in the sub-valve. The sub-valve is disposed coaxially with the main valve further downward from the main valve, namely, on a side closer to the solenoid 3 than the main valve. In other words, as shown in FIG. 1, the control valve 1 is configured such that the power element 6, the main valve, the sub-valve, and the solenoid 3 are arranged in this order starting from one end side of the body 5. A main valve hole 20 and a main valve seat 22 are provided in the main passage. A sub-valve hole 32 and a sub-valve seat 34 are provided in the sub-passage.

[0023] Through the port 12, a pressure chamber 23, partitioned in an upper portion of the body 5, and the suction chamber are communicated with each other. And the refrigerant at a suction pressure P_s is led into the pressure chamber 23 through the port 12. The power element 6 is disposed in the pressure chamber 23. Through the port 14, the refrigerant at a discharge pressure P_d is introduced from the discharge chamber. Through the port 16, the refrigerant at a crank pressure P_c having passed through the main valve is led out toward the crankcase during a steady operation of the compressor. Also, through the port 16, the refrigerant at a crank pressure P_c discharged from the crankcase is led in at a startup of the compressor. At this time, the thus led-in refrigerant is introduced to the sub-valve. Through

the port 18, the refrigerant at the suction pressure P_s is led in during a steady operation of the compressor and, on the other hand, the refrigerant at the suction pressure P_s having passed through the sub-valve is led out toward the suction chamber at a startup of the compressor.

[0024] The main valve hole 20 and the sub-valve hole 32 are formed coaxially with each other, and a pressure chamber 24, disposed between the main valve 20 and the sub-valve hole 32, communicates with the port 16. A guiding passage 25 (functioning as a "first guiding passage") is provided between the port 14 and the pressure chamber 23. A guiding passage 26 (functioning as a "second guiding passage") is provided between the port 14 and the port 16. A guiding passage 27 (functioning as a "third guiding passage") is provided between the port 16 and the port 18. A sub-valve element 36 of stepped cylindrical shape is slidably inserted to these guiding passages. That is, the sub-valve element 36 is supported by the body at three points. The sub-valve seat 34 is formed on an upper surface of the solenoid 3. The sub-valve element 36 closes and opens the sub-valve by touching and leaving the sub-valve seat 34, respectively.

[0025] The main valve hole 20 is provided in a reduced diameter portion in an upper portion of the sub-valve element 36, and the main valve seat 22 is formed in a lower end opening of the main valve hole. Also, an elongated actuating rod 38 is provided along the axis line of the body 5. An upper half of the actuating rod 38 is inserted to the sub-valve element 36, whereas a lower half thereof is inserted to the solenoid 3. An upper end of the actuating rod 38 is slidably supported by an upper end of the sub-valve element 36, and the actuating rod 38 and the power element 6 are connected at ends thereof such that the actuating rod 38 can be operatively coupled or linked to the power element 6. A lower end of the actuating rod 38 is connected to a plunger 50 (described later) of the solenoid 3. The diameter of a middle part of the actuating rod 38 is enlarged, thereby forming the main valve element 30. The main valve element 30 closes and opens the main valve by touching and leaving the main valve seat 22 in the pressure chamber 24, respectively. Thereby the main valve element 30 regulates the flow rate of refrigerant flowing from the discharge chamber to the crankcase. The actuating rod 38 directly transmits the solenoidal force to the main valve element 30 and the sub-valve element 36.

[0026] When the sub-valve element 36 is seated on the sub-valve seat 34 with the result that the sub-valve is closed, the communication state of the pressure chamber 24 and the port 18 is blocked and the relief of refrigerant from the crankcase to the suction chamber is blocked. Also, when the sub-valve is opened with the sub-valve element 36 spaced apart from the sub-valve seat 34, the pressure chamber 24 and the port 18 come to communicate with each other and the relief of refrigerant from the crankcase to the suction chamber is permitted. Communicating holes 35 and 37 that communicate the inside and the outside of the sub-valve element

36 are formed in a middle part of and an upper portion of the sub-valve element 36, respectively. The communicating hole 35 communicates between the port 14 and the main valve hole 20, whereas the communicating hole 37 communicates between the port 16 and the pressure chamber 24.

[0027] A spring 44 (functioning as a "biasing member") that biases the sub-valve element 36 in a closing direction of the sub-valve is set between the sub-valve element 36 and the body 5. The power element 6 includes a bellows 45 (functioning as a "pressure-sensing section") that develops a displacement by sensing the suction pressure P_s . And the power element 6 generates an opposing force to oppose the solenoidal force by the displacement of the bellows 45. This opposing force is also transmitted to the main valve element 30 by way of the actuating rod 38.

[0028] The solenoid 3 includes a stepped cylindrical core 46, a bottomed cylindrical sleeve 48, which is so assembled as to seal off a lower-end opening of the core 46, a cylindrical plunger 50, which is housed in the sleeve 48 and which is disposed in a position opposite to the core 46 in the direction of axis line, a cylindrical bobbin 52, which is inserted around the core 46 and sleeve 48, an electromagnetic coil 54, wound around the bobbin 52, which generates a magnetic circuit when the solenoid 3 electrically conducts, a casing 56, which is so provided as to cover the electromagnetic coil 54 from outside and which also functions as a yoke, and an end member 58, which is so provided as to seal off a lower-end opening of the casing 56. In the present embodiment, the body 5, the core 46, the casing 56 and the end member 58 form a body for the whole control valve 1. A spring 47 (functioning as a "biasing member") that biases force in a direction separating the plunger 50 away from the core 46 is set between the plunger 50 and the core 46.

[0029] The valve unit 2 and the solenoid 3 are secured such that a lower end of the body 5 is press-fitted to an upper-end opening of the core 46. The pressure chamber 24 is formed between the core 46 and the sub-valve element 36. The actuating rod 38 is inserted to the core 46 such that the actuating rod 38 penetrates a center of the core 46 in the direction of axis line. The lower end of the actuating rod 38 is press-fitted to an upper half of the plunger 50, and the actuating rod 38 and the plunger 50 are coaxially connected to each other.

[0030] The actuating rod 38 is supported by the plunger 50 from below and is configured such that actuating rod 38 can be operatively coupled or linked to the main valve element 30, the sub-valve element 36 and the power element 6. The actuating rod 38 appropriately transmits the solenoidal force, which is a suction force generated between the core 46 and the plunger 50, to the main valve element 30 or the sub-valve element 36. At the same time, a drive force, which is generated by an expansion/contraction movement of the power element 6, is so exerted on the actuating rod 38 as to oppose the solenoidal force. Hereinafter, this drive force to oppose

the solenoidal force will be referred to as "pressure-sensing drive force" also. In other words, when the main valve is under control, the force adjusted by the solenoidal force and the pressure-sensing drive force acts on the main valve 30 and appropriately controls the opening degree of the main valve. While the main valve is being closed, the actuating rod 38 is displaced relative to the body 5 in accordance with the magnitude of the solenoidal force, pushes up the sub-valve element 36 and thereby opens the sub-valve. Thereby, a bleed function is achieved.

[0031] A ring-shaped shaft support member 60 is press-fitted on an upper end of the core 46, and the actuating rod 38 is slidably supported by the shaft support member 60 in the direction of axis line. A communicating groove in parallel with the direction of axis line is formed in a predetermined position of the outer periphery of the shaft support member 60. The crank pressure P_c of the pressure chamber 24 passes through the communicating groove and a communicating path 62, which is formed by the spacing between the actuating rod 38 and the core 46, and is then led into the sleeve 48 as well.

[0032] The communicating path 62 functions as a orifice by which the interior of the sleeve 48 functions as an oil damper chamber. In other words, in the present embodiment, the same type of oil as that contained in the refrigerant for lubrication of the compressor is introduced, in advance, into the sleeve 48 as part of a manufacturing process of the control valve 1. In the present embodiment, the communicating groove provided in the shaft support member 60 functions as a throttle passage, which gives resistance to the flow of oil into and out of the sleeve 48. By employing such a structure as this enables the sleeve 48 to function as the oil damper chamber and enables the micro-vibration and the like of the plunger 50 placed in the sleeve 48 to be suppressed. As a result, the occurrence of noise caused by such micro-vibration is prevented or suppressed. In a modification to the present embodiment, the arrangement may be such that the communicating path 62 functions as the throttle passage, which gives resistance to the flow of oil into and out of the sleeve 48. In other words, it is preferable that at least one of the communicating groove provided in the shaft support member 60 and the communicating path 62 functions as the throttle passage. Note that the spring 47 function as an off-spring that biases both the core 46 and the plunger 50 in a direction that in which they get mutually separated apart from each other.

[0033] The sleeve 48 is made of a nonmagnetic material. A plurality of communicating grooves 66 are provided, in parallel with the axis line, on a side of the plunger 50. A plurality of communicating grooves 68, which extend radially and communicates the inside and the outside of the plunger 50, is provided at a lower end surface of the plunger 50. Such a structure as this enables the crank pressure P_c to be led to a back pressure chamber 70 through the spacing between the plunger 50 and the sleeve 48 even though the plunger 50 is positioned at a bottom dead point as shown in FIG. 1.

[0034] A pair of connection terminals 72 connected to the electromagnetic coil 54 extend from the bobbin 52 and are led outside by passing through the end member 58. Note that only one of the pair of connection terminals 72 is shown in FIG. 1 for convenience of explanation. The end member 58 is installed in such a manner as to seal the entire structure inside the solenoid 3 contained in the casing 56 from below. The end member 58 is molded (injection molding) of a corrosion-resistant resin, and the resin material is filled into gaps between the casing 56 and the electromagnetic coil 54 also. With the resin material filled into the gaps between the casing 56 and the electromagnetic coil 54, the heat release performance is improved because the heat generated by the electromagnetic coil 54 is easily conveyed to the casing 56. The ends of the connection terminals 72 are led out from the end member 58 and connected to a not-shown external power supply.

[0035] FIG. 2 is a partially enlarged cross-sectional view of the upper half of FIG. 1. The body 5 is constituted by integrally assembling a first body 81 and a second body 82. The first body 81 is of a stepped cylindrical shape such that the outside diameter thereof is gets smaller in stages upwardly. Also, the first body 81 slidably supports a lower half of the sub-valve element 36 along the guiding passage 27 formed inside the first body 81. The second body 82, which is of a stepped cylindrical shape, is fixed such that a lower half thereof is inserted to an upper half of the first body 81. Since the body 5 is configured by coupling the first body 81 and second body 82 together as described above, the body 5 is configured such that the outside diameter thereof becomes smaller toward a power element 6 side from a solenoid 3 side. As a result, easiness to insert the body 5 into a mounting hole of the not-shown compressor is enhanced.

[0036] A communicating hole 83, which communicates the inside and outside of the second body 82, is provided in a lower lateral part of the second body 82. The port 14 is formed in an overlapped portion that is a region where the first body 81 and the second body 82 are overlapped with each other. The power element 6 is so provided as to be held inside the upper half of the second body 82. The inside diameter of the lower half of the second body 82 is slightly reduced and thereby the guiding passages 25 and 26 are formed. An O-ring 28 for sealing (functioning as a "sealing member") is provided in a sliding surface of the guiding passage 26. The O-ring 28 prevents the high-pressure refrigerant introduced through the port 14 from leaking into the port 16 by passing through a gap between the sub-valve element 36 and the guiding passage 26.

[0037] An upper surface 90 of the main valve element 30 functions not only as a "attaching/detaching portion" that closes and opens the main valve by touching and leaving the main valve seat 22, respectively, but also as an "engagement portion" that presses the sub-valve element 36 upward (in an opening direction of the sub-valve) with the main valve element 30 being seated on

the main valve seat 22. On the other hand, an upper surface 92 of the middle part of the sub-valve element 36 functions as a "stopper" that restricts an upward movement of the sub-valve element 36 when the upper surface 92 thereof is stopped by an underside of the second body 82. An upper end portion 94 of the actuating rod 38 is slidably inserted to an upper end of the sub-valve element 36, and the upper end portion 94 thereof also functions as a partition wall that isolates the pressure chamber 23 from other pressure chambers.

[0038] By employing such a structure like this, the actuating rod 38 is pushed down by the biasing force of the spring 47 (see FIG. 1) while the solenoid 3 is not electrically conducting. As a result, as shown in FIG. 2, the main valve element 30 is spaced apart from the main valve seat 22, and the main valve is fully opened. Although the sub-valve maintains its closed state by the biasing force of the spring 44, the displacement of the sub-valve element 36 in the downward direction is restricted when the sub-valve element 36 is seated on the sub-valve seat 34. In the present embodiment, the shape and the size of the sub-valve element 36 are set such that the upper surface 92 thereof is spaced apart from the underside of the second body 82 at a predetermined interval L1, while the sub-valve is in a closed state.

[0039] The power element 6 is so structured that an upper end opening of the bellows 45 is closed by a first stopper 84 ("base member") and a lower end opening thereof is closed by a second stopper 86 ("base member"). The first stopper 84 is of a stepped cylindrical shape, and extends in the direction of axis line inside the bellows 45. The second stopper 86 is of a disk shape, and a central part of the upper surface of the second stopper 86 is disposed counter to a lower end surface of the first stopper 84. The interior of the bellows 45 is an airtight reference pressure chamber S, and a spring 88 is interposed between the first stopper 84 and the second stopper 86 in such a manner as to bias the bellows 45 in an expanding direction. The reference pressure chamber S is in a vacuum state according to the present embodiment. The first stopper 84 is formed integrally with the end member 13. Thus, the first stopper 84 is fixed relative to the body 5. The bellows 45 expands or contracts in the direction of axis line (opening/closing direction of the main valve) according to a pressure difference between the suction pressure Ps of the pressure chamber 23 and the reference pressure of the reference pressure chamber S. However, if the pressure difference becomes large, the end surfaces of the first stopper 84 and the second stopper 86 will abut against each other and will be stopped thereby as a result of a predetermined contraction of the bellows 45, thus restricting the contraction.

[0040] In the above-described structure, the main valve element 30 and the main valve seat 22 constitute a main valve, and the opening degree of the main valve regulates the flow rate of refrigerant flowing from the discharge chamber to the crankcase. Also, the sub-valve element 36 and the sub-valve seat 34 constitute a sub-

valve, and the opening/closing of the sub-valve permits or shuts off the delivery of refrigerant from the crankcase to the suction chamber. In other words, the control valve 1 functions as a three-way valve, too, by opening either the main valve or the sub-valve.

[0041] According to the present embodiment, an effective pressure-receiving diameter **A** (seal section diameter) of the sub-valve element 36 in the sub-valve and an effective pressure-receiving diameter **B** (seal section diameter) of the sliding portion of the sub-valve element 36 relative to the guiding passage 27 are set equal to each other. Thus, most of the effect of the crank pressure Pc acting on the sub-valve element 36 is cancelled. Also, an effective pressure-receiving diameter **C** (seal section diameter) of the sliding portion of the sub-valve element 36 relative to the guiding passage 25 and an effective pressure-receiving diameter **D** (seal section diameter) of the sliding portion of the sub-valve element 36 relative to the guiding passage 26 are set equal to each other. Thus, the effect of the discharge pressure Pd acting on the sub-valve element 36 is cancelled.

[0042] That is, the effect of the crank pressure Pc is canceled as to a portion of the sub-valve element 36 where a large portion thereof has been formed to occupy. Also, a pressure difference (Pc - Ps) between the crank pressure Pc and the suction pressure Ps acts on a smaller-diameter part, which is the upper half of the sub-valve element 36. However, this pressure difference is relatively small and therefore the force by the pressure difference will not be larger than the biasing force by the spring 44 in a closing direction of the sub-valve. Thus, the closed state of the sub-valve can be stably kept when the compressor is under control, even though the sub-valve element 36 is configured in a relatively large size. Hence, at the startup of the compressor, the sub-valve can be quickly opened by starting the solenoid 3. In other words, since the effect of the crank pressure Pc is canceled as to the portion where the sub-valve element 36 is formed in a large size, the load that the sub-valve element 36 receives on account of the pressure difference (Pc - Ps) will not be large even though the size of this portion is changed. Accordingly, the size of the sub-valve element 36 can be set freely. Also, an effective pressure-receiving diameter **E** (seal section diameter) of the main valve element 30 in the main valve and an effective pressure-receiving diameter **F** (seal section diameter) of the sliding portion of the main valve element 30 are set equal to each other. Thereby, the effect of the discharge pressure Pd acting on the main valve element 30 is canceled and the behavior of the main valve element 30, while the main valve is being controlled, can be stably maintained.

[0043] In such a structure as described above, the main valve operates autonomously so that, in a stable controlled state of the control valve 1, the suction pressure Ps of the pressure chamber 23 becomes a predetermined set pressure Pset. The set pressure Pset is basically adjusted beforehand by the spring loads of the springs 44, 47 and 88 and the load of the bellows 45, and

is set as a pressure value at which the freezing of the evaporator can be prevented in view of the relationship between the temperature inside the evaporator and the suction pressure P_s . The set pressure P_{set} can be changed by varying the supply current (set current) to the solenoid 3. In the present embodiment, the load setting of the springs can be fine-adjusted by readjusting a press-fitting amount of the end member 13 when the assembly of the control valve 1 is nearly completed. By employing this method, the set pressure P_{set} can be adjusted with accuracy.

[0044] When, at the startup of the control valve 1, the solenoid 3 electrically conducts and thereby the actuating rod 38 is displaced relative to the sub-valve element 36, the main valve element 30 is seated on the main valve seat 22 so as to close the main valve. As a result, the valve-opening-direction drive force can be supplied to the sub-valve element 36 via the main valve element 30. This can lift the sub-valve element 36 from the sub-valve seat 34 so as to open the sub-valve. In other words, the control valve 1 has a "forcible valve-opening mechanism" or "valve-opening mechanism" used to forcibly open the sub-valve using the drive force of the solenoid 3. If the sub-valve element 36 is locked as a result of the entanglement of foreign material in the sliding portions of sub-valve element 36 relative to the guiding passages 25, 26 and 27, this forcible valve-opening mechanism will function as a lock release mechanism (interlocking mechanism, pressing mechanism, etc.) as well.

[0045] Now, an operation of the control valve will be explained. FIG. 3 and FIG. 4 are each a diagram to explain an operation of the control valve, and FIG. 3 and FIG. 4 correspond to FIG. 2. FIG. 2, already described above, shows a state where the control valve operates with the minimum capacity. FIG. 3 shows a state where a bleed function is in effect. FIG. 4 shows a relatively stable controlled state. A description is given hereinbelow based on FIG. 1 with reference to FIG. 2 to FIG. 4, as appropriate.

[0046] While the solenoid 3 of the control valve 1 is not electrically conducting, namely while the automotive air conditioner is not operating, no suction power between the core 46 and the plunger 50 is in effect. At the same time, the suction pressure P_s is relatively high. Thus, as shown in FIG. 2, bellows 45 contracts and the power element 6 is substantially disabled. Also, the actuating rod 38 is pushed down by the biasing force of the spring 47, and the main valve element 30 is separated apart from the main valve seat 22 and therefore the main valve is fully opened. On the other hand, the state, where the sub-valve element 36 is seated on the sub-valve seat 34 by the biasing force of the spring 44, is kept and therefore the sub-valve remains closed.

[0047] On the other hand, when a control current is supplied to the electromagnetic coil 54 of the solenoid 3 at the startup or the like of the automotive air conditioner, the actuating rod 38 is driven in an upward direction by the solenoidal force as shown in FIG. 3 with the result

that the main valve is closed and the sub-valve is opened. In other words, displacing the actuating rod 38 relative to the sub-valve element 36 has the main valve element 30 seated on the main valve seat 22 and then closes the main valve. Subsequently, further displacing the actuating rod 38 relative to the body 5, while the main valve element 30 is being seated on the main valve seat 22, has the sub-valve element 36 separated away from the sub-valve seat 34 and then opens the sub-valve. However, stopping the upper surface 92 of the sub-valve element 36 by the body 5 restricts an uplift amount of the sub-valve element 36 (i.e., the opening degree of the sub-valve). Note also that the suction pressure P_s is relatively high normally at the startup and thus the bellows 45 maintains its contracted state so as to maintain the state where the sub-valve is being open.

[0048] In other words, supplying the starting current to the solenoid 3 causes the main valve to be closed and thereby restricts the delivery of discharged refrigerant into the crankcase. At the same time, supplying the starting current thereto opens the sub-valve so as to promptly relieve the refrigerant in the crankcase into the suction chamber. This can promptly start the compressor. Even when the suction pressure P_s is low and the bellows 45 has been expanded, such as when a vehicle is exposed to a low-temperature environment, supplying a large current to the solenoid 3 enables the sub-valve to be opened and therefore the compressor can be promptly started.

[0049] Even if, at the start of the control valve 1 like this, the entry of foreign material into the sliding portion of the sub-valve element 36 has caused the sub-valve element 36 to be locked in a valve opening direction, the locking can be released by pressing the sub-valve element 36 with the solenoidal force. Also, if the entry of foreign material into the sliding portion of the sub-valve element 36 has caused the sub-valve element 36 to be locked in a valve closing direction, the locking can be released when the suction pressure P_s drops and the bellows 45 expands, with the startup of the control valve, and then the second stopper 86 abuts against an upper end surface of the sub-valve element 36 and presses the sub-valve element 36 downward.

[0050] Then, in the controlled state where the value of current supplied to the solenoid 3 is set to a predetermined value, the suction pressure P_s is relatively low as shown in FIG. 4. Thus, the bellows 45 expands and is operatively coupled to the actuating rod 38. Thereby, the main valve 30 moves so as to regulate the opening degree of the main valve. At this time, the main valve element 30 stops at a valve-lift position. This valve-lift position is a position where three forces are all balanced thereamong. Here, the three forces are the force by the spring 47 in the valve opening direction, the solenoidal force by the solenoid 3 in the valve closing direction, and the opposing force, to oppose the solenoidal force, generated by the power element 6 operated according to the suction pressure P_s . Since the state, where the sub-valve element 36 is seated on the sub-valve seat 34 by the

biasing force of the spring 44, is kept in the controlled state of the main valve, the closed state of the sub-valve is maintained.

[0051] As, for example, the refrigeration load becomes large and the suction pressure P_s becomes higher than the set pressure P_{set} , the bellows 45 contracts and therefore the main valve element 30 is displaced relatively upward (in the valve closing direction). As a result, the opening degree of the main valve becomes small and therefore the compressor operates in such a manner as to increase the discharging capacity. As a result, a change is made in a direction where the suction pressure P_s drops. Conversely, as the refrigeration load becomes small and then the suction pressure P_s becomes lower than the set pressure P_{set} , the bellows 45 expands. As a result, the biasing force by the power element 6 works in such a direction as to oppose the solenoidal force. As a result, the force toward the main valve element 30 in the valve closing direction is reduced and the opening degree of the main valve becomes large. Thus, the compressor operates in such a manner as to reduce the discharging capacity. As a result, the suction pressure P_s is kept at the set pressure P_{set} .

[0052] If the engine load gets larger during such a steady control operation and therefore a reduction in the load to the air conditioner is desired, the conduction state (on/off) of the solenoid 3 is switched from on to off in the control valve 1. This means that no suction power is in effect between the core 46 and the plunger 50. Thus the main valve element 30 gets separated away from the main valve seat 22 by the biasing force of the spring 47, and the main valve is fully opened. At this time, the sub-valve element 36 is seated on the sub-valve seat 34 and therefore the sub-valve is closed. The refrigerant, at the discharge pressure P_d , introduced into the port 16 from the discharge chamber of the compressor passes through the fully opened main valve and flows into the crankcase from the port 14. Thus, the crank pressure P_c rises and then the compressor performs the minimum capacity operation.

[0053] As described so far, in the present embodiment, the sub-valve seat 34 is not formed in the main valve element 30 but is formed as a part of the body 5. Accordingly, the sizes of the sub-valve hole 32 and the sub-valve element 36 can be set regardless of the size of the main valve element 30. In other words, the size of the sub-valve can be set regardless of the size of the main valve. In particular, the sub-valve is provided on a side closer to the solenoid 3, namely, on the side where the outside diameter of the body 5 is larger, so that the sub-valve element 36 can be sufficiently made large. Thus, a large flow rate of refrigerant is obtained when the sub-valve is opened, and therefore the bleed function can be enhanced. Since the main valve seat 22 is formed integrally with the sub-valve element 36, the number of components used can be reduced. Furthermore, the main valve seat 22 (seat forming section) and the sub-valve element 36 are formed integrally with each other. Thus,

the sub-valve element 36, which is formed integrally with the main valve seat 22, moves to open the sub-valve simultaneously with the movement of said main valve seat 22 after the closing of the main valve. It is therefore no longer required to adjust separately the timing with which the main valve is closed and the timing with which the sub-valve is opened. This can reduce the time otherwise spent for selecting the particular parts required and the positions to be adjusted, thereby markedly improving the assemblability.

[Second Embodiment]

[0054] FIG. 5 is a partially enlarged cross-sectional view of the upper half of a control valve according to a second embodiment. The structure of a valve unit in the control valve according to the second embodiment slightly differs from the valve unit in the first embodiment. Thus, a description is hereinbelow given centering around different features from the first embodiment. Note that the structural components in FIG. 5 closely similar to those of the first embodiment are given the identical reference numerals.

[0055] The structures of a body 205 and a sub-valve element 236 in a valve unit 202 of a control valve 201 differ from those in the first embodiment. In the second embodiment, too, the body 205, the core 46, the casing 56, and the end member 58 constitute a body for the entire control valve 201. The body 205 is constituted by a first body 81 and a second body 282. The guiding passage 25 of the second body 282 slidably supports the upper end portion 94 of the actuating rod 38. A spring support member 240 is provided below the main valve element 30 in the actuating rod 38. A spring 242 (functioning as a "biasing member") that biases the sub-valve element 236 in an opening direction of the sub-valve is set between the sub-valve element 236 and the spring support member 240. Note that the spring 47 as shown in FIG. 1 is not provided in the second embodiment.

[0056] The sub-valve element 236 is supported by the guiding passage 26 and the guiding passage 27 at two points. An O-ring 228 for sealing (functioning as a "sealing member") is provided in a surface of the sub-valve element 236 opposite to the guiding passage 27. The O-ring 228 prevents the refrigerant introduced through the port 16 from leaking into the port 18 by passing through a gap between the sub-valve element 236 and the guiding passage 27.

[0057] In this second embodiment, too, the effective pressure-receiving diameter **E** (seal section diameter) of the main valve element 30 in the main valve and the effective pressure-receiving diameter **F** (seal section diameter) of the sliding portion of the actuating rod 38 are set equal to each other. Thereby, the effect of the discharge pressure P_d acting on the main valve element 30 is canceled and the control of the main valve is stabilized. Although, in the second embodiment, the actuating rod 38 and the plunger 50 are not fixed as in the first embod-

iment, the actuating rod 38 is biased, by a reaction force of the spring 242, toward the plunger 50. Thus, the contact state where the actuating rod 38 and the plunger 50 abut against each other can be constantly maintained. In other words, a structure according to the second embodiment is such that the actuating rod 38 does not need to be press-fitted to the plunger 50.

[Third Embodiment]

[0058] FIG. 6 is a partially enlarged cross-sectional view of the upper half of a control valve according to a third embodiment. The control valve according to the third embodiment differs from that according to the first embodiment in that a main valve seat is formed in a valve seat forming member that is provided separately. Thus, a description is hereinbelow given centering around different features from the first embodiment. Note that the structural components in FIG. 6 closely similar to those of the first embodiment are given the identical reference numerals.

[0059] In a control valve 301, a body in a valve unit 302 is constituted by a first body 81 and a second body 382. In the third embodiment, too, the body 305, the core 46, the casing 56, and the end member 58 constitute a body for the entire control valve 301. A discoidal partition member 380 by which to partition the pressure chamber 23 is press-fitted to an upper portion of the second body 382. And the guiding passage 25 is so formed as to run through the partition member 380. The guiding passage 25 slidably supports the upper end portion 94 of the actuating rod 38. A pair of ring-shaped stoppers 340 and 342 are fitted, in a lower part of a main valve element 330 in the actuating rod 38, at a predetermined interval in the direction of axis line.

[0060] A cylindrical valve seat forming member 350 is slidably inserted along the guiding passage 26. The valve seat forming member 350 has a stopper 352 that extends radially outward at an upper end thereof. A spring 344, which biases the valve seat forming member 350 downward (functioning as a "biasing member") is set between the stopper 352 and the partition member 380. The main valve hole 20 is formed inside the valve seat forming member 350, and the main valve seat 22 is formed in a lower end opening thereof.

[0061] A sub-valve element 336, which is of a bottomed cylindrical shape, is configured such that the bottom thereof is supported between the stopper 340 and stopper 342. A plurality of communicating holes 337 through which the refrigerant flows is formed at the bottom of the sub-valve element 336. In this third embodiment, too, the effective pressure-receiving diameter **E** (seal section diameter) of the main valve element 330 in the main valve and the effective pressure-receiving diameter **F** (seal section diameter) of the sliding portion of the actuating rod 38 are set equal to each other. Thereby, the effect of the discharge pressure P_d acting on the main valve element 330 is canceled and the control of the main valve

is stabilized.

[0062] By employing such a structure like this, the sub-valve element 336 maintains the closed state of the sub-valve by the biasing force of the spring 44, as shown in FIG. 6, while the solenoid 3 is not electrically conducting. The valve seat forming member 350 maintains a state where the stopper 352 is stopped by the second body 382. Since the actuating rod 38 is pushed down by the spring 47 (see FIG. 1), the main valve element 330 is spaced apart from the main valve seat 22 and then the main valve is fully opened. In the third embodiment, an uplift amount L_2 of the main valve element 330 from the main valve seat 22 and an interval L_3 between a bottom lower surface of the sub-valve element 336 and the stopper 342 are set that, in this state, the uplift amount L_2 and the interval L_3 are equal to each other.

[0063] In a stable controlled state of the control valve 301, the main valve element 330 is pushed up by the solenoidal force, and the uplift amount thereof from the main valve seat 22 is basically smaller than the uplift amount L_2 . Since the stopper 342 is not engaged with the sub-valve element 336 in a state where the main valve element 330 is being lifted, the sub-valve will not be opened. The main valve element 330 operates autonomously so that the suction pressure P_s of the pressure chamber 23 becomes a predetermined set pressure P_{set} .

[0064] When, at the startup of the control valve 301, the solenoid 3 electrically conducts and thereby the actuating rod 38 is displaced relative to the sub-valve element 336, the main valve element 330 is seated on the main valve seat 22 so as to close the main valve. As a result, the valve-opening-direction drive force can be supplied to the sub-valve element 336 via the main valve element 330. This can lift the sub-valve element 336 from the sub-valve seat 34 so as to open the sub-valve. In other words, the control valve 301 also has a "forcible valve-opening mechanism" or "valve-opening mechanism" used to forcibly open the sub-valve using the drive force of the solenoid 3. If the sub-valve element 336 is locked as a result of the entanglement of foreign material in the sliding portions of sub-valve element 336 relative to the guiding passages 26 and 27, this forcible valve-opening mechanism will function as a lock release mechanism (interlocking mechanism, pressing mechanism, etc.) as well.

[Fourth Embodiment]

[0065] FIG. 7 is a partially enlarged cross-sectional view of the upper half of a control valve according to a fourth embodiment. The structure of a valve unit in the control valve according to the fourth embodiment slightly differs from the valve unit in the first embodiment. Thus, a description is hereinbelow given centering around different features from the first embodiment. Note that the structural components in FIG. 7 closely similar to those of the first embodiment are given the identical reference

numerals.

[0066] In a control valve 401, a body 405 in a valve unit 402 is constituted by assembling a first body 481 and a second body 482. In the fourth embodiment, too, the body 405, the core 46, the casing 56, and the end member 58 constitute a body for the entire control valve 401. A main valve is provided inside the second body 482, and a sub-valve is provided between the first body 481 and the second body 482. The second body 482 is secured such that a lower half thereof is inserted to an upper half of the first body 481. The port 14 is formed on an upper half side of an overlapped portion that is a region where the first body 481 and the second body 482 are overlapped with each other. Also, the port 16 is formed on a lower half side thereof.

[0067] A main valve element 430, which is of a stepped cylindrical shape, is slidably supported, in the direction of axis line, along a guiding passage 25 provided in a central part of the second body 482 and a guiding passage 426 provided in a lower end of the second body 482. The main valve hole 20 is formed between the guiding passage 25 and the guiding passage 426 in the second body 482, and the main valve seat 22 is formed in a lower end opening of the main valve hole 20. The outside diameter of the main valve element 430 in a central part thereof in the direction of axis line is reduced, and a bottom base end of this reduced diameter portion constitutes an attaching/detaching portion where the main valve is closed and opened by touching and leaving the main valve seat 22, respectively. A labyrinth seal 495 having a plurality of annular grooves by which to restrict the passage of refrigerant is provided in a surface of the main valve element 430 facing the guiding passage 25. The pressure chamber 23 is formed above the main valve element 430.

[0068] Also, the sub-valve hole 32 is formed in the first body 481 below the second body 482, and the sub-valve seat 34 is formed in an upper-end opening of the sub-valve hole 32. A sub-valve element 436, which is of a bottomed cylindrical shape, is slidably inserted around the lower end of the second body 482. A through-hole 441 is formed in a bottom center of the sub-valve element 436, and the actuating rod 38 is so provided as to penetrate the sub-valve element 436 and the main valve element 430. A stopper 498 is secured to a middle part of the actuating rod 38, and the upper surface of the stopper 498 forms an engagement portion 496. As the actuating rod 38 moves in the upward direction and then the stopper 498 engages itself with the underside of the sub-valve element 436, an upward force (in a closing direction of the sub-valve) is transmitted to the sub-valve element 436. A stopper 499 is also secured to an upper end of the actuating rod 38. As the actuating rod 38 moves in the downward direction and then the stopper 499 engages itself with the upper surface of the main valve element 430, a downward force (in an opening direction of the main valve) is transmitted to the main valve element 430.

[0069] The sub-valve element 436 is so disposed as

to be held between the underside of the main valve element 430 and the engagement portion 496. A spring 444 (functioning as a "biasing member"), which biases in a direction that mutually separates the main valve element 430 and the sub-valve element 436 away, is provided between the main valve element 430 and the sub-valve element 436. A pressure chamber 428, which is filled with the refrigerant at the suction pressure P_s , is formed between the sub-valve element 436 and the core 46. The pressure chamber 428 communicates with the port 18. A plurality of communicating holes 435 are formed in the vicinity of a peripheral edge of a bottom of the sub-valve element 436. A space surrounded by the second body 482, the main valve element 430, and the sub-valve element 436 forms a pressure chamber 490. The suction pressure P_s of the pressure chamber 428 is also introduced to the pressure chamber 490 through the communicating holes 435.

[0070] In the fourth embodiment, when the main valve is fully opened (when the sub-valve is closed), the position of the engagement portion 496 is set such that the engagement portion 496 in the actuating rod 38 and the sub-valve element 436 are spaced apart from each other at a predetermined interval L_1 . In the fourth embodiment, the predetermined interval L_1 is set equal to the uplift amount of the main valve element 430 from the main valve seat 22 at the time the main valve is fully opened. This prevents the sub-valve from being opened in a controlled state of the main valve. Also, the distance between the sub-valve element 436 and the main valve element 430, when the main valve is closed, corresponds to a fully-opened stroke.

[0071] In this fourth embodiment, the effective pressure-receiving diameter E (seal section diameter) of the main valve element 430 in the main valve and the effective pressure-receiving diameter F (seal section diameter) of an upper sliding portion of the main valve element 430 are set equal to each other. Thus, the effect of the discharge pressure P_d acting on the main valve element 430 is canceled. Here, an effective pressure-receiving diameter G (seal section diameter) of a lower sliding portion of the main valve element 430 is set larger than the effective pressure-receiving diameter F (seal section diameter) of the upper sliding portion of the main valve element 430. Thus, a pressure difference ($P_c - P_s$) in a valve-opening direction corresponding to a difference ($G - F$) in diameter, acts on the main valve element 430. Also, a pressure difference ($P_c - P_s$) in a valve-closing direction corresponding to a difference ($A - B$) between the effective pressure-receiving diameter A (seal section diameter) of the sub-valve element 436 in the sub-valve and the effective pressure-receiving diameter B (seal section diameter) of the sliding portion of the sub-valve element 436, acts on the sub-valve element 436.

[0072] In a stable controlled state of the control valve 401, the valve-lift position of the main valve element 430 is controlled such that the force in a valve-closing direction by the spring 444, the force in the valve-closing di-

rection by the solenoid 3, the valve-opening direction by the power element 6, and the force in the valve-opening direction by the spring 47 are all well-balanced. The main valve element 430 operates autonomously so that the suction pressure P_s of the pressure chamber 23 becomes a predetermined set pressure P_{set} . At this time, the sub-valve element 436 is biased in a valve-closing direction by the reaction force of the spring 444, so that the sub-valve will not be opened then.

[0073] When, at the startup of the control valve 401, the solenoid 3 electrically conducts and thereby the actuating rod 38 is displaced relative to the sub-valve element 436, the stopper 498 is engaged with the sub-valve element 436 so as to push up the sub-valve element 436. This can lift the sub-valve element 436 from the sub-valve seat 34 so as to open the sub-valve. In other words, the control valve 401 has a "forcible valve-opening mechanism" or "valve-opening mechanism" used to forcibly open the sub-valve using the drive force of the solenoid 3. If each valve element is locked as a result of the entanglement of foreign material in the sliding portions of the main valve element 430 and the sub-valve element 436, this forcible valve-opening mechanism will function as a lock release mechanism (interlocking mechanism, pressing mechanism, etc.) as well.

[0074] The description of the present invention given above is based upon illustrative embodiments. These embodiments are intended to be illustrative only and it will be obvious to those skilled in the art that various modifications could be further developed within the technical idea underlying the present invention.

[0075] In each of the above-described embodiments, the so-called P_s sensing valve, which is enabled upon sensing the suction pressure P_s as the pressure-to-be-sensed, is described as a control valve. Instead, the control valve may be constituted as a so-called P_c sensing valve, which is enabled upon sensing the crank pressure P_c . In such a case, the structure will be such that the port 12 communicates with the crankcase.

[0076] In the above-described embodiments, the description has been given of examples where the bellows 45 is used for a pressure-sensing member that constitutes the power element 6. A diaphragm may be used, instead. In such a case, the structure may be such that a plurality of diaphragms are coupled in the direction of axis line in order to ensure a necessary running stroke required for the pressure-sensing member.

[0077] In each of the above-described embodiments, a description has been given of an example where a single port 14 is provided as the "crankcase communication port" (lead-in/out port) that communicates with the crankcase. In a modification, the crankcase communication port may be structured that it is divided into a first port (lead-out port), which is used to lead out the refrigerant, which has passed through the main valve, to the crankcase, and a second port (lead-in port), which is used to introduce the refrigerant of the crankcase.

[0078] In the above-described embodiments, the de-

scription has been given of examples where a spring (coil spring) is used as the biasing member regarding the springs 44, 47, 242, 344, 444 and the like. It goes without saying that an elastic material, such as rubber or resin, or an elastic mechanism, such as a plate spring, may be used instead.

[0079] In each of the above-described embodiments, a description has been given of a control valve of inflow type where the flow rate or pressure of refrigerant introduced into the crankcase from the discharge chamber of the variable displacement compressor is regulated. In a modification, it may be configured as a control valve of outflow type where the flow rate or pressure of refrigerant introduced into the suction chamber from the crankcase is regulated. Also, the structure according to each of the above-described embodiments is applicable to a composite valve, such as a three-way valve under other modes, as long as a main valve and a sub-valve are provided in a common body and it is driven by a single solenoid.

[0080] In each of the above-described embodiments, a description has been given of the case where the reference pressure chamber S inside the bellows 45 is in a vacuum state. Instead, the reference pressure chamber S may be filled with air or filled with a predetermined gas serving as a reference. Or alternatively, it may be so filled as to have any one of the discharge pressure P_d , the crank pressure P_c , and the suction pressure P_s . In such a case, the power element 6 may be configured such that the power element 6 is activated by sensing, as appropriate, the pressure difference between the interior and exterior of the bellows. Also, in each of the above-described embodiments, a description has been given of the structure where the discharge pressure P_d is canceled as to the main valve element. Instead, the structure may be such that the pressure received by the main valve element is not canceled.

[0081] In each of the above-described embodiments, a description has been given of the structure where the power element 6 is capable of being in contact with the sub-valve element 36, so that, should the sub-valve element 36 be locked, the locked state can be released by the drive force of the power element 6. In a modification, the structure may be as follows. That is, in the case where, as shown in FIG. 6, the seat forming member is provided separately from the sub-valve element seat forming member, the power element 6 is made capable of being contact with the seat forming member, so that, in the even that the valve forming member is locked, the locked state can be released by the drive force of the power element 6.

[0082] The present invention is not limited to the above-described embodiments and modifications only, and those components may be further modified to arrive at various other embodiments without departing from the scope of the invention. Also, various other embodiments may be further formed by combining, as appropriate, a plurality of structural components disclosed in the above-

described embodiments and modification. Also, one or some of all of the components exemplified in the above-described embodiments and modifications may be left unused or removed.

Claims

1. A control valve (1, 201, 301, 401) for a variable displacement compressor for varying a discharging capacity of the compressor for compressing refrigerant led into a suction chamber and discharging the compressed refrigerant from a discharge chamber, by regulating a flow rate or pressure of at least one of the refrigerant led into a crankcase from the discharge chamber and the refrigerant led out to the suction chamber from the crankcase, the control valve (1, 201, 301, 401) comprising:

a body (5, 46, 56, 58, 205, 305, 405) having a main passage, which communicates between the discharge chamber and the crank case, and a sub-passage, which communicates between the crankcase and the suction chamber;

a main valve seat (22) provided in the main passage;

a main valve element (30, 330, 430) configured to open and close a main valve by touching and leaving the main valve seat (22);

a sub-valve seat (34) provided in the sub-passage;

a sub-valve element (36, 236, 336, 436) configured to open and close a sub-valve by touching and leaving the sub-valve seat (34);

a pressure-sensing section (6) configured to sense a predetermined pressure-to-be-sensed and configured to generate a drive force exerted in an opening direction of the main valve in accordance with a magnitude of the pressure-to-be-sensed;

a solenoid (3) configured to generate a drive force in a closing direction of the main valve in accordance with an amount of current supplied; and

a valve-opening mechanism configured to open the sub-valve by using a drive force of the solenoid (3),

wherein the pressure-sensing section (6), the main valve, the sub-valve, and the solenoid (3) are arranged in this order from one end side of the body (5, 46, 56, 58, 205, 305, 405),

characterized in that

the sub-valve element (36, 236, 336, 436) is arranged such that the sub-valve is opened on a side closer to the solenoid than the main valve.

2. A control valve (1, 201, 301, 401) according to claim 1, further comprising an actuating rod (38) config-

ured to transmit the drive forces of the pressure-sensing section (6) and the solenoid (3) to the main valve and the sub-valve, the actuating rod (38) being disposed between the pressure-sensing section (6) and the solenoid (3),

wherein the valve-opening mechanism is a mechanism where after the main valve has been closed, the sub-valve is opened by moving the actuating rod (38).

3. A control valve (1, 201, 301) according to claim 1 or claim 2, wherein the body (5, 205, 305) includes a guiding passage (27) that slidably supports the sub-valve element (36, 236, 336), and

wherein a seal section diameter (A) in the sub-valve of the sub-valve element (36, 236, 336) and a seal section diameter (B) of a sliding portion of the sub-valve element (36, 236, 336) relative to the guiding passage (27) are set equal to each other, whereby at least part of effect of crank pressure (Pc) inside the crankcase or a suction pressure (Ps) inside the suction chamber acting on the sub-valve element (36, 236, 336) is canceled.

4. A control valve (401) according to claim 1 or claim 2, further comprising:

the main valve seat (22) provided in a part of body (405);

the sub-valve seat (34) disposed opposite to the pressure-sensing section (6) relative to the main valve seat (22) of the body (405); and

an actuating rod (38) configured to transmit the drive forces of the pressure-sensing section (6) and the solenoid (3) to the main valve and the sub-valve, the actuating rod (38) being disposed between the pressure-sensing section (6) and the solenoid (3),

wherein the actuating rod (38) has an engagement portion (498) capable of directly transmitting the drive force of the solenoid (3) by engaging the engagement portion (498) with the sub-valve element (436), and

wherein the valve-opening mechanism opens the sub-valve in such a manner that the actuating rod (38) is displaced relative to the main valve element (430) after the main valve has been closed and such that the sub-valve element (436) is separated away from the sub-valve seat (34) by pressing the sub-valve element (436) via the engagement portion (498).

5. A control valve (401) according to claim 4, wherein the main valve element (430) is slidably supported by the body (405), and wherein a seal section diameter (E) in the main valve of the main valve element (430) and a seal section diameter (F) of a sliding portion of the main valve element (430) are set equal

to each other, whereby an effect of discharge pressure (Pd) of the discharge chamber acting on the main valve element (430) is canceled.

6. A control valve (1, 201, 301) for a variable displacement compressor for varying a discharging capacity of the compressor for compressing refrigerant led into a suction chamber and discharging the compressed refrigerant from a discharge chamber, by regulating a flow rate or pressure of at least one of the refrigerant led into a crankcase from the discharge chamber and the refrigerant led out to the suction chamber from the crankcase, the control valve (1, 201, 301, 401) comprising:

a body (5, 46, 56, 58, 205, 305, 405) having a main passage, which communicates between the discharge chamber and the crank case, and a sub-passage, which communicates between the crankcase and the suction chamber;

a main valve seat (22) provided in the main passage;

a main valve element (30, 330, 430) configured to open and close a main valve by touching and leaving the main valve seat (22);

a sub-valve seat (34) provided in the sub-passage;

a sub-valve element (36, 236, 336, 436) configured to open and close a sub-valve by touching and leaving the sub-valve seat (34); a pressure-sensing section (6) configured to sense a predetermined pressure-to-be-sensed and configured to generate a drive force exerted in an opening direction of the main valve in accordance with a magnitude of the pressure-to-be-sensed;

a solenoid (3) configured to generate a drive force in a closing direction of the main valve in accordance with an amount of current supplied; an actuating rod (38) configured to transmit the drive forces of the pressure-sensing section (6) and the solenoid (3) to the main valve and the sub-valve, the actuating rod (38) being disposed between the pressure-sensing section (6) and the solenoid (3); and a valve-opening mechanism configured to open the sub-valve by using a drive force of the solenoid (3),

wherein the valve-opening mechanism is a mechanism where after the main valve has been closed, the sub-valve is opened by moving the actuating rod (38); and wherein the pressure-sensing section (6), the main valve, the sub-valve, and the solenoid (3) are arranged in this order from one end side of the body (5, 46, 56, 58, 205, 305, 405),

characterized in that

the sub-valve seat (34) is provided in a part of the body (5, 46, 56, 58, 205, 305); and the control

valve (1, 201, 301) further comprises a valve seat forming section (36, 236, 350) configured to be slidably supported by the body (5, 205, 305), the valve seat forming section (36, 236, 350) being formed integrally with the main valve seat (22); and

the main valve element (30, 330) is configured to close and open the main valve by touching and leaving the main valve seat (22), respectively, the main valve element (30, 330) being formed integrally and freely movable with the actuating rod (38) wherein the valve-opening mechanism is configured to open the sub-valve in a manner such that

the main valve element (30, 330) is seated on the main valve seat (22) by moving the actuating rod (38), and

the sub-valve element (36, 236, 336) is separated away from the sub-valve seat (34), by pressing and displacing the valve seat forming section (36, 236, 350) via the main valve element (30, 330).

7. A control valve (1, 201) according to claim 6, wherein the valve seat forming section (36, 236) is integrally formed with the sub-valve element (36, 236), and wherein the valve-opening mechanism is configured to open the sub-valve in a manner such that the sub-valve element (36, 236) is separated away from the sub-valve seat (34) by moving the actuating rod (38) and pressing the sub-valve element (36, 236) via the main valve element (30).

8. A control valve (1, 201, 301) according to claim 6 or claim 7, wherein the body (5, 205, 305) includes a guiding passage (27) that slidably supports the sub-valve element (36, 236, 336), and wherein a seal section diameter (A) in the sub-valve of the sub-valve element (36, 236, 336) and a seal section diameter (B) of a sliding portion of the sub-valve element (36, 236, 336) relative to the guiding passage (27) are set equal to each other, whereby at least part of effect of crank pressure (Pc) inside the crankcase or a suction pressure (Ps) inside the suction chamber acting on the sub-valve element (36, 236, 336) is canceled.

9. A control valve (1, 201, 301) according to any one of claim 6 to claim 8, further comprising an actuating rod (38) configured to transmit the drive forces of the pressure-sensing section (6) and the solenoid (3) to the main valve and the sub-valve, the actuating rod (38) being disposed between the pressure-sensing section (6) and the solenoid (3), wherein the actuating rod (38) is slidably supported by the body (205, 305) or the sub-valve element (36), and wherein a seal section diameter (E) in the main valve

of the main valve element (30, 330) and a seal section diameter (F) of a sliding portion of the actuating rod (38) are set equal to each other, whereby an effect of discharge pressure (Pd) of the discharge chamber acting on the main valve element (30, 330) is canceled.

10. A control valve (1, 201, 301) according to any one of claim 6 to claim 9, further comprising a valve seat forming section (36, 236, 350) configured to be slidably supported by the body (5, 205, 305), the valve seat forming section (36, 236, 350) being formed integrally with the main valve seat (22), wherein the body (5, 205, 305) has a discharge chamber communication port (14) communicating with the discharge chamber, a crankcase communication port (16) communicating with the crankcase, and another guiding passage (26) formed between the discharge chamber communication port (14) and the crankcase communication port (16), wherein the sub-valve element (36, 236) or the valve seat forming section (350) is slidably supported along the other guiding passage (26), and wherein a sealing member (28) for restricting leakage of the refrigerant is provided between the sub-valve element (36, 236) or the valve seat forming section (350) and the other guiding passage (26).
11. A control valve (1, 201, 301) according to any one of claim 6 to claim 10, further comprising, when dependent on any of claims 3 to 6, a valve seat forming section (36, 236, 350) configured to be slidably supported by the body (5, 205, 305), the valve seat forming section (36, 236, 350) being formed integrally with the main valve seat (22), wherein the pressure-sensing section (6) is configured such that the pressure-sensing section (6) is contactable with at least one of end surfaces of the main valve element (30, 330), the sub-valve element (36) and the valve seat forming section (36).

Patentansprüche

1. Regelventil (1, 201, 301, 401) für einen Verdichter mit variabler Verdrängung zur Veränderung einer Auslasskapazität des Verdichters zum Verdichten eines in eine Ansaugkammer eingeleiteten Kühlmittels und zum Auslassen des verdichteten Kühlmittels aus einer Auslasskammer, durch Regelung einer Strömungsgeschwindigkeit oder des Drucks von mindestens dem Kühlmittel, das aus der Auslasskammer in ein Kurbelgehäuse geleitet wird, oder dem Kühlmittel, das aus dem Kurbelgehäuse zur Ansaugkammer geleitet wird, wobei das Regelventil (1, 201, 301, 401) folgendes aufweist:

einen Ventilkörper (5, 46, 56, 68, 205, 305, 405)

mit einem Hauptdurchlass, der zwischen der Auslasskammer und dem Kurbelgehäuse eine Verbindung herstellt, und einem Nebendurchlass, der zwischen dem Kurbelgehäuse und der Ansaugkammer eine Verbindung herstellt; einen Hauptventilsitz (22), der in dem Hauptdurchlass vorgesehen ist; ein Hauptventilelement (30, 330, 430), das so ausgelegt ist, dass es ein Hauptventil öffnet und schließt, indem es den Hauptventilsitz (22) berührt und verlässt; einen Nebenventilsitz (34), der in dem Nebendurchlass vorgesehen ist; ein Nebenventilelement (36, 236, 336, 436), das so ausgelegt ist, dass es ein Nebenventil öffnet und schließt, indem es den Nebenventilsitz (34) berührt und verlässt; einen Druckerfassungsabschnitt (6), der so ausgelegt ist, dass er einen vorgegebenen und zu erfassenden Druck fühlt und der so vorgesehen ist, dass er eine Antriebskraft erzeugt, die in Öffnungsrichtung des Hauptventils entsprechend der Stärke des zu erfassenden Drucks ausgeübt wird; einen Magneten (3), der so ausgelegt ist, dass er in Schließrichtung des Hauptventils in Entsprechung zur Stärke eines zugeführten Stroms eine Antriebskraft erzeugt; und eine Ventilöffnungsmechanik, die so ausgelegt ist, dass sie das Nebenventil unter Einsatz einer Antriebskraft von dem Magneten (3) öffnet, bei welchem der Druckerfassungsabschnitt (6), das Hauptventil, das Nebenventil und der Magnet (3) in dieser Reihenfolge von einem Ende des Ventilkörpers (5, 46, 56, 58, 205, 305, 405) aus angeordnet sind, **dadurch gekennzeichnet, dass** das Nebenventilelement (36, 236, 336, 436) in der Weise angeordnet ist, dass das Nebenventil auf einer Seite geöffnet wird, die näher zum Magneten hin als das Hauptventil liegt.

2. Regelventil (1, 201, 301, 401) nach Anspruch 1, welches des Weiteren eine Betätigungsstange (389) aufweist, die so ausgelegt ist, dass sie die Antriebskräfte des Druckerfassungsabschnitts (6) und des Magneten (3) auf das Hauptventil und das Nebenventil überträgt, wobei die Betätigungsstange (38) zwischen dem Druckerfassungsabschnitt (6) und dem Magneten (3) angeordnet ist, bei welchem es sich bei der Ventilöffnungsmechanik um eine Mechanik handelt, bei welcher nach dem Schließen des Hauptventils das Nebenventil geöffnet wird, indem die Betätigungsstange (38) bewegt wird.
3. Regelventil (1, 201, 301) nach Anspruch 1 oder Anspruch 2, bei welchem der Ventilkörper (5, 205, 305)

einen Führungsdurchlass (27) aufweist, welcher das Nebenventilelement (36, 236, 336) gleitend abstützt, und

bei welchem der Durchmesser (A) eines Abdichtbereichs in dem Nebenventil des Nebenventilelements (36, 236, 336) und der Durchmesser (B) eines Abdichtbereichs eines relativ zum Führungsdurchlass (27) gleitenden Abschnitts des Nebenventilelements (36, 236, 336) so eingestellt sind, dass sie gleich groß sind, wobei zumindest ein Teil der Wirkung des Kurbeldrucks (P_c) im Inneren des Kurbelgehäuses bzw. eines Ansaugdrucks (P_s) im Inneren der Ansaugkammer, der auf das Nebenventilelement (36, 226, 336) einwirkt, aufgehoben wird.

4. Regelventil (401) nach Anspruch 1 oder Anspruch 2, welches des Weiteren folgendes aufweist:

den in einem Teil des Ventilkörpers (405) vorgesehenen Hauptventilsitz;

den gegenüber dem Druckerfassungsabschnitt (6) relativ zum Hauptventilsitz (22) des Ventilkörpers (405) angeordneten Nebenventilsitz (34); und

eine Betätigungsstange (38), die so ausgelegt ist, dass sie die Antriebskräfte des Druckerfassungsabschnitts (6) und des Magneten (3) auf das Hauptventil und das Nebenventil überträgt, wobei die Betätigungsstange (38) zwischen dem Druckerfassungsabschnitt (6) und dem Magneten (3) angeordnet ist,

bei welchem die Betätigungsstange (38) einen Eingriffsabschnitt (498) aufweist, der in der Lage ist, die Antriebskraft des Magneten (3) direkt zu übertragen, indem der Eingriffsabschnitt (498) mit dem Nebenventilelement (436) in Eingriff gebracht wird, und bei welchem die Ventilöffnungsmechanik das Nebenventil in der Weise öffnet, dass nach dem Schließen des Hauptventils die Betätigungsstange (38) relativ zum Hauptventilelement (430) verlagert wird und dass das Nebenventilelement (436) von dem Nebenventilsitz (34) weg getrennt wird, indem über den Eingriffsabschnitt (498) auf das Nebenventilelement (436) Druck ausgeübt wird.

5. Regelventil (401) nach Anspruch 4, bei welchem das Hauptventilelement (430) gleitend von dem Ventilkörper (405) abgestützt wird, und bei welchem der Durchmesser (E) eines Abdichtbereichs in dem Hauptventil (430) des Hauptventilelements (430) und der Durchmesser (F) eines Abdichtbereichs eines gleitenden Abschnitts des Hauptventilelements (430) so eingestellt werden, dass sie gleich groß sind, wobei eine Wirkung des Auslassdrucks (P_d) der Auslasskammer, der auf das Hauptventilelement (430) einwirkt, aufgehoben wird.

6. Regelventil (1, 201, 301) für einen Verdichter mit variabler Verdrängung zur Veränderung einer Auslasskapazität des Verdichters zum Verdichten eines in eine Ansaugkammer eingeleiteten Kühlmittels und zum Auslassen des verdichteten Kühlmittels aus einer Auslasskammer, durch Regelung einer Strömungsgeschwindigkeit oder des Drucks von mindestens dem Kühlmittel, das aus der Auslasskammer in ein Kurbelgehäuse geleitet wird, oder dem Kühlmittel, das aus dem Kurbelgehäuse zur Ansaugkammer geleitet wird, wobei das Regelventil (1, 201, 301, 401) folgendes aufweist:

einen Ventilkörper (5, 46, 56, 68, 205, 305, 405) mit einem Hauptdurchlass, der zwischen der Auslasskammer und dem Kurbelgehäuse eine Verbindung herstellt, und einem Nebendurchlass, der zwischen dem Kurbelgehäuse und der Ansaugkammer eine Verbindung herstellt;

einen Hauptventilsitz (22), der in dem Hauptdurchlass vorgesehen ist;

ein Hauptventilelement (30, 330, 430), das so ausgelegt ist, dass es ein Hauptventil öffnet und schließt, indem es den Hauptventilsitz (22) berührt und verlässt;

einen Nebenventilsitz (34), der in dem Nebendurchlass vorgesehen ist;

ein Nebenventilelement (36, 236, 336, 436), das so ausgelegt ist, dass es ein Nebenventil öffnet und schließt, indem es den Nebenventilsitz (34) berührt und verlässt;

einen Druckerfassungsabschnitt (6), der so ausgelegt ist, dass er einen vorgegebenen und zu erfassenden Druck fühlt und der so vorgesehen ist, dass er eine Antriebskraft erzeugt, die in Öffnungsrichtung des Hauptventils in Entsprechung zur Stärke des zu erfassenden Drucks ausgeübt wird;

einen Magneten (3), der so ausgelegt ist, dass er in Schließrichtung des Hauptventils in Entsprechung zur Stärke eines zugeführten Stroms eine Antriebskraft erzeugt;

eine Betätigungsstange (38), die so ausgelegt ist, dass sie die Antriebskräfte des Druckerfassungsabschnitts (6) und des Magneten (3) auf das Hauptventil und das Nebenventil überträgt, wobei die Betätigungsstange (38) zwischen dem Druckerfassungsabschnitt (6) und dem Magneten (3) angeordnet ist; und

eine Ventilöffnungsmechanik, die so ausgelegt ist, dass sie das Nebenventil unter Einsatz einer Antriebskraft des Magneten (3) öffnet;

bei welchem es sich bei der Ventilöffnungsmechanik um eine Mechanik handelt, bei welcher nach dem Schließen des Hauptventils das Nebenventil durch Bewegen der Betätigungsstange (38) geöffnet wird, bei welchem der Druckerfassungsabschnitt (6),

das Hauptventil, das Nebenventil und der Magnet (3) in dieser Reihenfolge von einem Ende des Ventilkörpers (5, 46, 56, 58, 205, 305, 405) aus angeordnet sind,

dadurch gekennzeichnet, dass der Nebenventilsitz (34) in einem Teil des Ventilkörpers (5, 46, 56, 58, 205, 305) vorgesehen ist und dass das Regelventil (1, 201, 301) des Weiteren folgendes aufweist:

einen Bereich (36, 236, 350) zur Bildung eines Ventilsitzes, der so ausgelegt ist, dass er von dem Ventilkörper (5, 204, 305) gleitend abgestützt wird, während der Bereich (36, 236, 350) zur Bildung eines Ventilsitzes integral mit dem Hauptventilsitz (22) ausgebildet ist; und

das Hauptventilelement (30, 330) so ausgebildet ist, dass es das Hauptventil schließt und öffnet, indem es den Hauptventilsitz (22) berührt bzw. verlässt, wobei das Hauptventilelement (30, 330) integral mit der Betätigungsstange (38) und frei beweglich mit dieser ausgebildet ist, während die Ventilöffnungsmechanik so ausgelegt ist, dass sie das Nebenventil in der Weise öffnet, dass

- das Hauptventilelement (30, 330) auf dem Hauptventilsitz (22) aufgesetzt wird, indem die Betätigungsstange (38) bewegt wird, und

- das Nebenventilelement (36, 236, 336) von dem Nebenventilsitz (34) weg getrennt wird, indem über das Hauptventilelement (30, 330) auf den Bereich (36, 236, 350) zur Bildung eines Ventilsitzes Druck ausgeübt und dieser dabei verlagert wird.

7. Regelventil (1, 201) nach Anspruch 6, bei welchem der Bereich (36, 236) zur Bildung eines Ventilsitzes integral mit dem Nebenventilelement (36, 236) ausgebildet ist, und bei welchem die Ventilöffnungsmechanik so ausgelegt ist, dass sie das Nebenventil in der Weise öffnet, dass das Nebenventilelement (36, 236) von dem Nebenventilsitz (34) weg getrennt wird, indem die Betätigungsstange (38) bewegt wird und über das Hauptventilelement (30) auf das Nebenventilelement (36, 236) Druck ausgeübt wird.
8. Regelventil (1, 201, 301) nach Anspruch 6 oder Anspruch 7, bei welchem der Ventilkörper (5, 205, 305) einen Führungsdurchlass (27) umfasst, welcher das Nebenventilelement (36, 236, 336) gleitend abstützt, und bei welchem der Durchmesser (A) eines Abdichtbe-

reichs in dem Nebenventil des Nebenventilelements (36, 236, 336) und der Durchmesser (B) eines relativ zu dem Führungsdurchlass (27) gleitenden Abschnitts des Nebenventilelements (36, 236, 336) so eingestellt sind, dass sie gleich groß sind, wobei zumindest ein Teil der Wirkung des Kurbeldrucks (P_c) im Inneren des Kurbelgehäuses bzw. ein Ansaugdruck (P_s) im Inneren der Ansaugkammer, der auf das Nebenventilelement einwirkt (36, 236, 336) aufgehoben wird.

9. Regelventil (1, 201, 301) nach einem der Ansprüche 6 bis 8, welches des Weiteren eine Betätigungsstange (38) aufweist, die so ausgelegt ist, dass sie die Antriebskräfte des Druckerfassungsabschnitts (6) und des Magneten (3) auf das Hauptventil und das Nebenventil überträgt, wobei die Betätigungsstange zwischen dem Druckerfassungsabschnitt (6) und dem Magneten (3) angeordnet ist, bei welchem die Betätigungsstange (38) gleitend von dem Ventilkörper (205, 305) oder dem Nebenventilelement (36) abgestützt wird, und bei welchem der Durchmesser (E) eines Abdichtbereichs in dem Hauptventil des Hauptventilelements (30, 330) und der Durchmesser (F) eines gleitenden Abschnitts der Betätigungsstange (38) so eingestellt sind, dass sie gleich groß sind, wobei die Wirkung des Auslassdrucks (P_d) im Inneren der Auslasskammer, der auf das Hauptventilelement (30, 330) einwirkt (36, 236, 336) aufgehoben wird.
10. Regelventil (1, 201, 301) nach einem der Ansprüche 6 bis 9, welches des Weiteren einen Bereich (36, 236, 350) zur Bildung eines Ventilsitzes aufweist, der so ausgelegt ist, dass er gleitend von dem Ventilkörper (5, 205, 305) abgestützt wird, wobei der Bereich (36, 236, 350) integral mit dem Hauptventilsitz (22) ausgebildet ist, bei welchem der Ventilkörper (5, 205, 305) eine Anschlussöffnung (14) zur Verbindung der Auslasskammer aufweist, die mit der Auslasskammer in Verbindung steht, sowie eine Anschlussöffnung (16) zur Verbindung des Kurbelgehäuses, die mit dem Kurbelgehäuse in Verbindung steht, und einen weiteren Führungsdurchlass (26), der zwischen der Anschlussöffnung (14) zur Verbindung der Auslasskammer und der Anschlussöffnung (16) zur Verbindung des Kurbelgehäuses ausgebildet ist, bei welchem das Nebenventilelement (36, 2336) oder der Bereich (350) zur Bildung eines Ventilsitzes entlang des anderen Führungsdurchlasses (267) gleitend abgestützt werden, und bei welchem ein Dichtungselement (28) zur Einschränkung des Austritts von Kühlmittel zwischen dem Nebenventilelement (36, 236) oder dem Bereich (350) zur Bildung eines Ventilsitzes und dem anderen Führungsdurchlass (26) vorgesehen ist.

11. Regelventil (1, 201, 301) nach einem der Ansprüche 6 bis 10, welches des Weiteren dann, wenn Abhängigkeit von einem der Ansprüche 3 bis 6 gegeben ist, ein Bereich (36, 236, 350) zur Bildung eines Ventilsitzes so ausgelegt ist, dass er gleitend von dem Ventilkörper (5, 205, 305) abgestützt wird, wobei der Bereich (36, 236, 350) zur Bildung eines Ventilsitzes integral mit dem Hauptventilsitz (22) ausgebildet ist, bei welchem der Druckerfassungsabschnitt (6) so ausgelegt ist, dass der Druckerfassungsabschnitt (6) mit mindestens einer der Endflächen des Hauptventilelements (30, 330), des Nebenventilelements (36) und des Bereichs (36) zur Bildung eines Ventilsitzes in Berührung bringbar ist.

Revendications

1. Soupape de régulation (1, 201, 301, 401) pour un compresseur à cylindrée variable pour modifier une capacité de décharge du compresseur pour comprimer du réfrigérant amené dans une chambre d'aspiration et décharger le réfrigérant comprimé dans une chambre de décharge, en régulant un débit ou une pression d'au moins l'un parmi le réfrigérant amené dans un carter de vilebrequin depuis la chambre de décharge et le réfrigérant guidé vers la chambre d'aspiration depuis le carter de vilebrequin, la soupape de régulation (1, 201, 301, 401) comprenant :

un corps (5, 46, 56, 58, 205, 305, 405) ayant un passage principal, qui communique entre la chambre de décharge et le carter de vilebrequin et un passage auxiliaire qui communique entre le carter de vilebrequin et la chambre d'aspiration ;

un siège de soupape principale (22) prévu dans le passage principal ;

un élément de soupape principale (30, 330, 430) configuré pour ouvrir et fermer une soupape principale en touchant et en s'éloignant du siège de soupape principale (22) ;

un siège de soupape auxiliaire (34) prévu dans le passage auxiliaire ;

un élément de soupape auxiliaire (36, 236, 336, 436) configuré pour ouvrir et fermer une soupape auxiliaire en touchant et en s'éloignant du siège de soupape auxiliaire (34) ;

une section de détection de pression (6) configurée pour détecter une pression à détecter prédéterminée et configurée pour générer une force d'entraînement exercée dans une direction d'ouverture de la soupape principale selon une grandeur de la pression à détecter ;

un solénoïde (3) configuré pour générer une force d'entraînement dans une direction de fermeture de la soupape principale selon une quantité

de courant fourni ; et

un mécanisme d'ouverture de soupape configuré pour ouvrir la soupape auxiliaire en utilisant une force d'entraînement du solénoïde (3), dans laquelle la section de détection de pression (6), la soupape principale, la soupape auxiliaire et le solénoïde (3) sont agencés dans cet ordre à partir d'un côté d'extrémité du corps (5, 46, 56, 58, 205, 305, 405),

caractérisée en ce que :

l'élément de soupape auxiliaire (36, 236, 336, 436) est agencé de sorte que la soupape auxiliaire est ouverte sur un côté plus proche du solénoïde que la soupape principale.

2. Soupape de régulation (1, 201, 301, 401) selon la revendication 1, comprenant en outre une tige d'actionnement (38) configurée pour transmettre les forces d'entraînement de la section de détection de pression (6) et du solénoïde (3) à la soupape principale et à la soupape auxiliaire, la tige d'actionnement (38) étant disposée entre la section de détection de pression (6) et le solénoïde (3), dans laquelle le mécanisme d'ouverture de soupape est un mécanisme dans lequel, après que la soupape principale a été fermée, la soupape auxiliaire est ouverte en déplaçant la tige d'actionnement (38).

3. Soupape de régulation (1, 201, 301) selon la revendication 1 ou la revendication 2, dans laquelle le corps (5, 205, 305) comprend un passage de guidage (27) qui supporte, de manière coulissante l'élément de soupape auxiliaire (36, 236, 336), et dans laquelle un diamètre de section de joint d'étanchéité (A) dans la soupape auxiliaire de l'élément de soupape auxiliaire (36, 236, 336) et un diamètre de section de joint d'étanchéité (B) d'une partie coulissante de l'élément de soupape auxiliaire (36, 236, 336) par rapport au passage de guidage (27) sont égaux entre eux, moyennant quoi au moins une partie de l'effet de pression de vilebrequin (Pc) à l'intérieur du carter de vilebrequin ou d'une pression d'aspiration (Ps) à l'intérieur de la chambre d'aspiration agissant sur l'élément de soupape auxiliaire (36, 236, 336) est annulé.

4. Soupape de régulation (401) selon la revendication 1 ou la revendication 2, comprenant en outre :

le siège de soupape principale (22) prévu dans une partie du corps (405) ;

le siège de soupape auxiliaire (34) disposé à l'opposé de la section de détection de pression (6) par rapport au siège de soupape principale (22) du corps (405) ; et

une tige d'actionnement (38) configurée pour

- transmettre les forces d'entraînement de la section de détection de pression (6) et du solénoïde (3) à la soupape principale et à la soupape auxiliaire, la tige d'actionnement (38) étant disposée entre la section de détection de pression (6) et le solénoïde (3),
 dans laquelle la tige d'actionnement (38) a une partie de mise en prise (498) capable de transmettre directement la force d'entraînement du solénoïde (3) en mettant en prise la partie de mise en prise (498) avec l'élément de soupape auxiliaire (436), et
 dans laquelle le mécanisme d'ouverture de soupape ouvre la soupape auxiliaire de sorte que la tige d'actionnement (38) est déplacée par rapport à l'élément de soupape principale (430) après que la soupape principale a été fermée et de sorte que l'élément de soupape auxiliaire (436) est séparé du siège de soupape auxiliaire (34) en comprimant l'élément de soupape auxiliaire (436) via la partie de mise en prise (498).
5. Soupape de régulation (401) selon la revendication 4, dans laquelle l'élément de soupape principale (430) est supporté de manière coulissante par le corps (405), et dans laquelle un diamètre de section de joint d'étanchéité (E) dans la soupape principale de l'élément de soupape principale (430) et un diamètre de section de joint d'étanchéité (F) d'une partie coulissante de l'élément de soupape principale (430) sont égaux entre eux, moyennant quoi un effet de pression de décharge (Pd) de la chambre de décharge agissant sur l'élément de soupape principale (430) est annulé.
6. Soupape de régulation (1, 201, 301) pour un compresseur à cylindrée variable pour modifier une capacité de décharge du compresseur afin de comprimer du réfrigérant amené dans une chambre d'aspiration et décharger le réfrigérant comprimé d'une chambre de décharge, en régulant un débit ou une pression d'au moins l'un parmi le réfrigérant amené dans un carter de vilebrequin depuis la chambre de décharge et le réfrigérant guidé vers la chambre d'aspiration depuis le carter de vilebrequin, la soupape de régulation (1, 201, 301, 401) comprenant :
- un corps (5, 46, 56, 58, 205, 305, 405) ayant un passage principal, qui communique entre la chambre de décharge et le carter de vilebrequin, et un passage auxiliaire qui communique entre le carter de vilebrequin et la chambre d'aspiration ;
 - un siège de soupape principale (22) prévu dans le passage principal ;
 - un élément de soupape principale (30, 330, 430) configuré pour ouvrir et fermer une soupape principale en touchant et en s'éloignant du siège

de soupape principale (22) ;
 un siège de soupape auxiliaire (34) prévu dans le passage auxiliaire ;
 un élément de soupape auxiliaire (36, 236, 336, 436) configuré pour ouvrir et fermer une soupape auxiliaire en touchant et en s'éloignant du siège de soupape auxiliaire (34) ;
 une section de détection de pression (6) configurée pour détecter une pression à détecter prédéterminée et configurée pour générer une force d'entraînement exercée dans une direction d'ouverture de la soupape principale selon une grandeur de la pression à détecter ;
 un solénoïde (3) configuré pour générer une force d'entraînement dans une direction de fermeture de la soupape principale selon une quantité de courant fourni ;
 une tige d'actionnement (38) configurée pour transmettre les forces d'entraînement de la section de détection de pression (6) et du solénoïde (3) à la soupape principale et à la soupape auxiliaire, la tige d'actionnement (38) étant disposée entre la section de détection de pression (6) et le solénoïde (3) ; et
 un mécanisme d'ouverture de soupape configuré pour ouvrir la soupape auxiliaire en utilisant une force d'entraînement du solénoïde (3), dans laquelle le mécanisme d'ouverture de soupape est un mécanisme dans lequel, après que la soupape principale a été fermée, la soupape auxiliaire est ouverte en déplaçant la tige d'actionnement (38) ; et
 dans laquelle la section de détection de pression (6), la soupape principale, la soupape auxiliaire et le solénoïde (3) sont agencés dans cet ordre à partir d'un côté d'extrémité du corps (5, 46, 56, 58, 205, 305, 405),
caractérisée en ce que :

le siège de soupape auxiliaire (34) est prévu dans une partie du corps (5, 46, 56, 58, 205, 305) ; et la soupape de régulation (1, 201, 301) comprend en outre :

- une section de formation de siège de soupape (36, 236, 350) configurée pour être supportée de manière coulissante par le corps (5, 205, 305), la section de formation de siège de soupape (36, 236, 350) étant formée de manière solide avec le siège de soupape principale (22) ; et
- l'élément de soupape principale (30, 330) est configuré pour fermer et ouvrir la soupape principale en touchant et en s'éloignant du siège de soupape principale (22), respectivement, l'élément de soupape principale (30, 330) étant

formé de manière solidaire et librement mobile avec la tige d'actionnement (38), dans laquelle le mécanisme d'ouverture de soupape est configuré pour ouvrir la soupape auxiliaire de sorte que :

l'élément de soupape principale (30, 330) est installé sur le siège de soupape principale (22) en déplaçant la tige d'actionnement (38), et

l'élément de soupape auxiliaire (36, 236, 336) est séparé du siège de soupape auxiliaire (34), en comprimant et en déplaçant la section de formation de siège de soupape (36, 236, 350) via l'élément de soupape principale (30, 330).

7. Soupape de régulation (1, 201) selon la revendication 6, dans laquelle la section de formation de siège de soupape (36, 236) est formée de manière solidaire avec l'élément de soupape auxiliaire (36, 236), et dans laquelle le mécanisme d'ouverture de soupape est configuré pour ouvrir la soupape auxiliaire de sorte que l'élément de soupape auxiliaire (36, 236) est séparé du siège de soupape auxiliaire (34) en déplaçant la tige d'actionnement (38) et en comprimant l'élément de soupape auxiliaire (36, 236) via l'élément de soupape principale (30).
8. Soupape de régulation (1, 201, 301) selon la revendication 6 ou la revendication 7, dans laquelle le corps (5, 205, 305) comprend un passage de guidage (27) qui supporte de manière coulissante l'élément de soupape auxiliaire (36, 236, 336), et dans laquelle un diamètre de section de joint d'étanchéité (A) dans la soupape auxiliaire de l'élément de soupape auxiliaire (36, 236, 336) et un diamètre de section de joint d'étanchéité (B) d'une partie coulissante de l'élément de soupape auxiliaire (36, 236, 336) par rapport au passage de guidage (27) sont égaux entre eux, moyennant quoi au moins une partie de l'effet de la pression de vilebrequin (Pc) à l'intérieur du carter de vilebrequin ou d'une pression d'aspiration (Ps) à l'intérieur de la chambre d'aspiration agissant sur l'élément de soupape auxiliaire (36, 236, 336) est annulé.
9. Soupape de régulation (1, 201, 301) selon l'une quelconque des revendications 6 à 8, comprenant en outre une tige d'actionnement (38) configurée pour transmettre les forces d'entraînement de la section de détection de pression (6) et du solénoïde (3) à la soupape principale et à la soupape auxiliaire, la tige d'actionnement (38) étant disposée entre la section

de détection de pression (6) et le solénoïde (3), dans laquelle la tige d'actionnement (38) est supportée de manière coulissante par le corps (205, 305) ou l'élément de soupape auxiliaire (36), et dans laquelle un diamètre de section de joint d'étanchéité (E) dans la soupape principale de l'élément de soupape principale (30, 33) et un diamètre de section de joint d'étanchéité (F) d'une partie coulissante de la tige d'actionnement (38) sont égaux entre eux, moyennant quoi un effet de pression de décharge (Pd) de la chambre de décharge agissant sur l'élément de soupape principale (30, 330) est annulé.

10. Soupape de régulation (1, 201, 301) selon l'une quelconque des revendications 6 à 9, comprenant en outre une section de formation de siège de soupape (36, 236, 350) configurée pour être supportée, de manière coulissante, par le corps (5, 205, 305), la section de formation de siège de soupape (36, 236, 350) étant formée de manière solidaire avec le siège de soupape principale (22), dans laquelle le corps (5, 205, 305) a un orifice de communication de chambre de décharge (14) communiquant avec la chambre de décharge, l'orifice de communication de carter de vilebrequin (16) communiquant avec le carter de vilebrequin, et un autre passage de guidage (26) formé entre l'orifice de communication de chambre de décharge (14) et l'orifice de communication de carter de vilebrequin (16), dans lequel l'élément de soupape auxiliaire (36, 236) ou la section de formation de siège de soupape (350) est supporté(e), de manière coulissante, le long de l'autre passage de guidage (26), et dans laquelle un élément d'étanchéité (28) pour limiter les fuites du réfrigérant est prévu entre l'élément de soupape auxiliaire (36, 236) ou la section de formation de siège de soupape (350) et l'autre passage de guidage (26).
11. Soupape de régulation (1, 201, 301) selon l'une quelconque des revendications 6 à 10, comprenant en outre, lorsqu'elle dépend de l'une quelconque des revendications 3 à 6, une section de formation de siège de soupape (36, 236, 350) configurée pour être supportée, de manière coulissante, par le corps (5, 205, 305), la section de formation de siège de soupape (36, 236, 350) étant formée de manière solidaire avec le siège de soupape principale (22), dans laquelle la section de détection de pression (6) est configurée de sorte que la section de détection de pression (6) peut être en contact avec au moins l'une des surfaces d'extrémité de l'élément de soupape principale (30, 330), l'élément de soupape auxiliaire (36) et la section de formation de siège de soupape (36).

FIG. 1

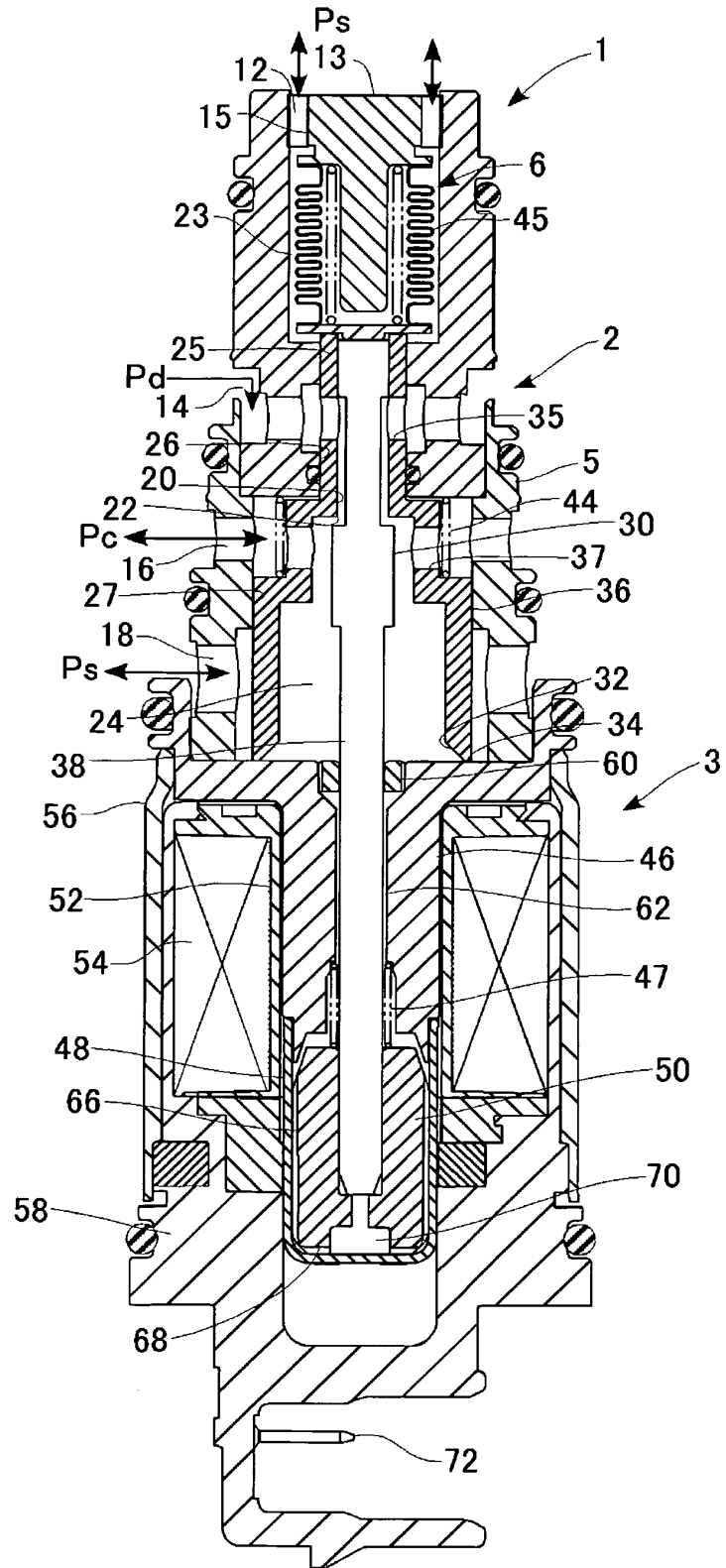

FIG. 2

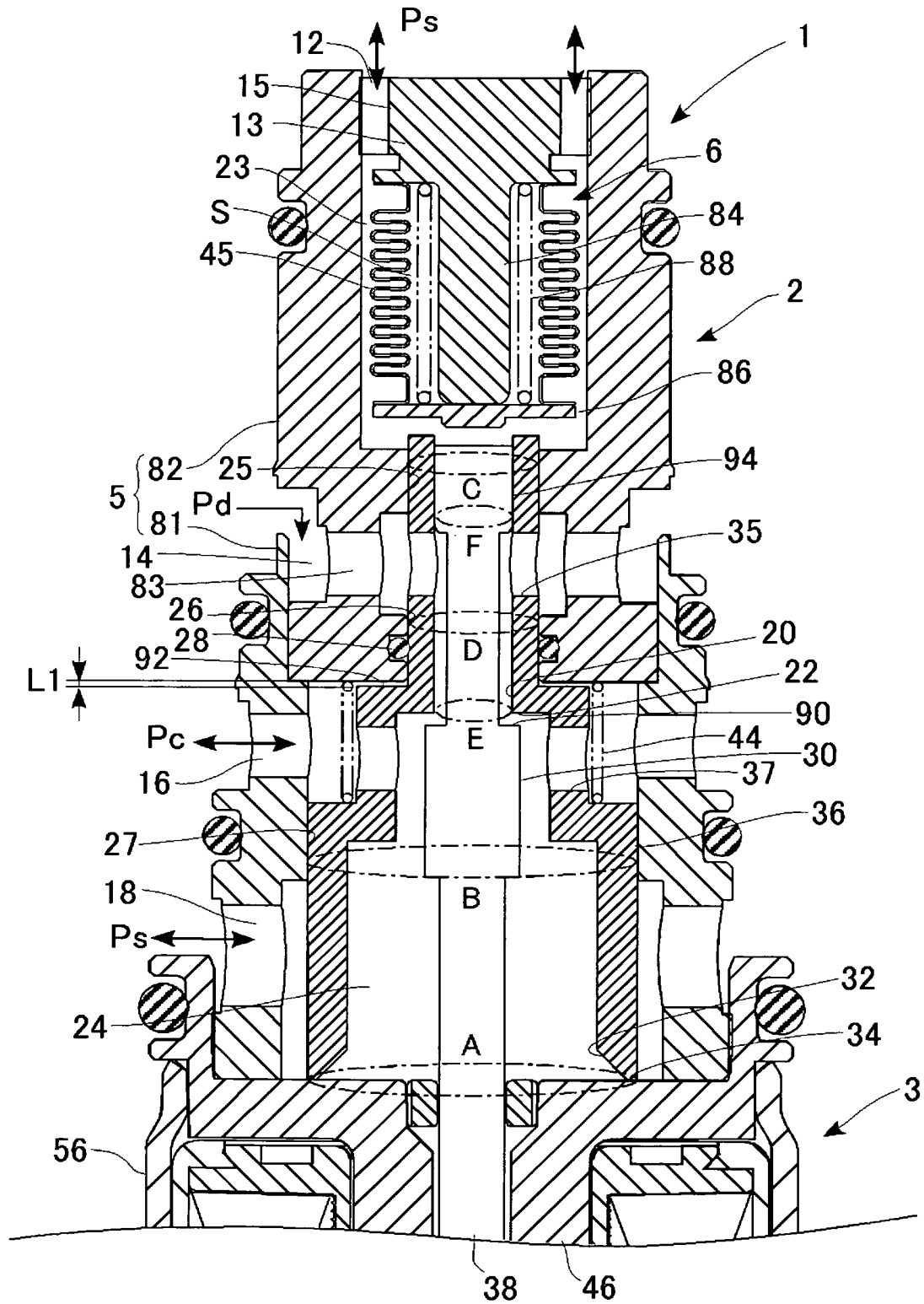

FIG. 3

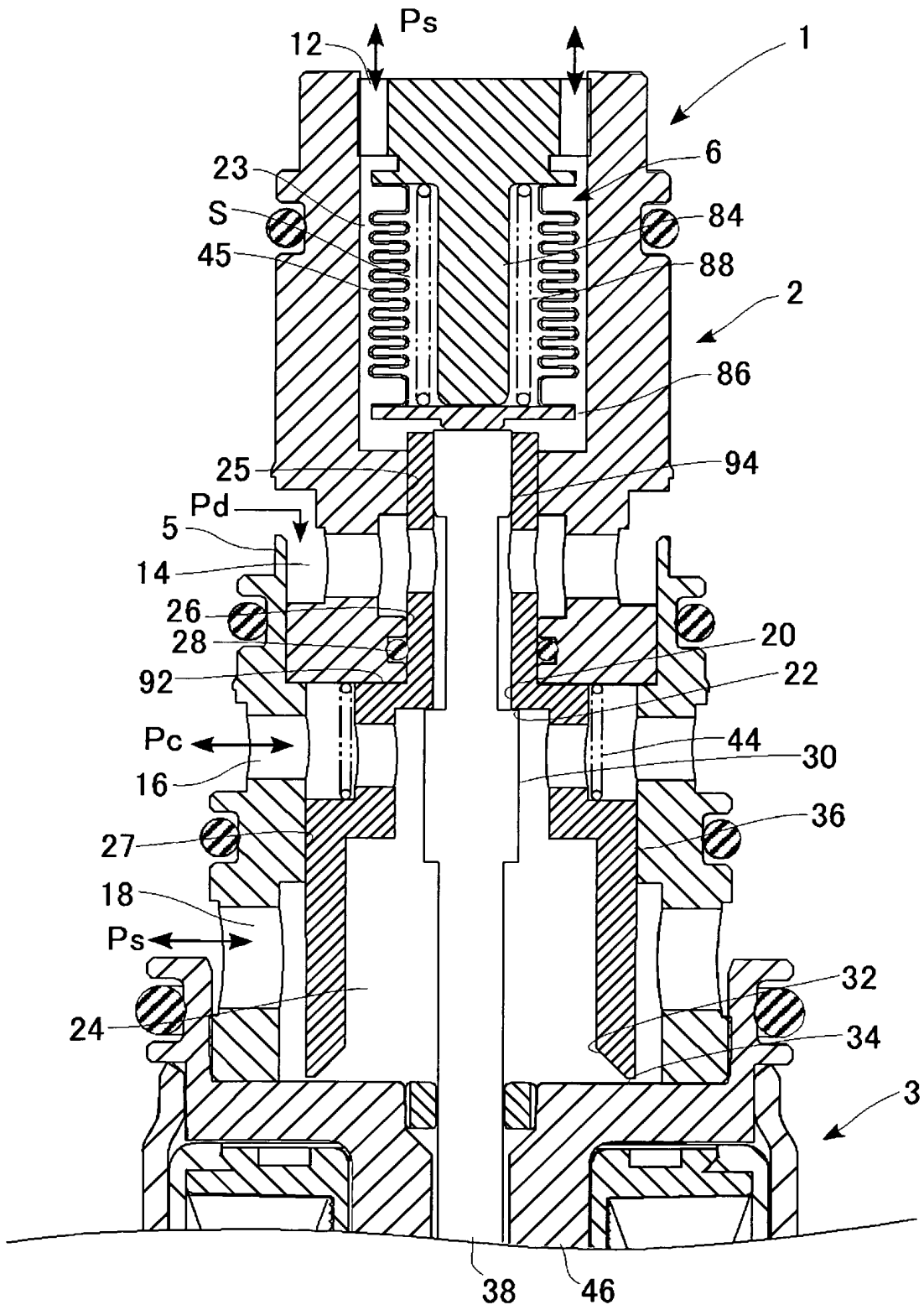

FIG. 4

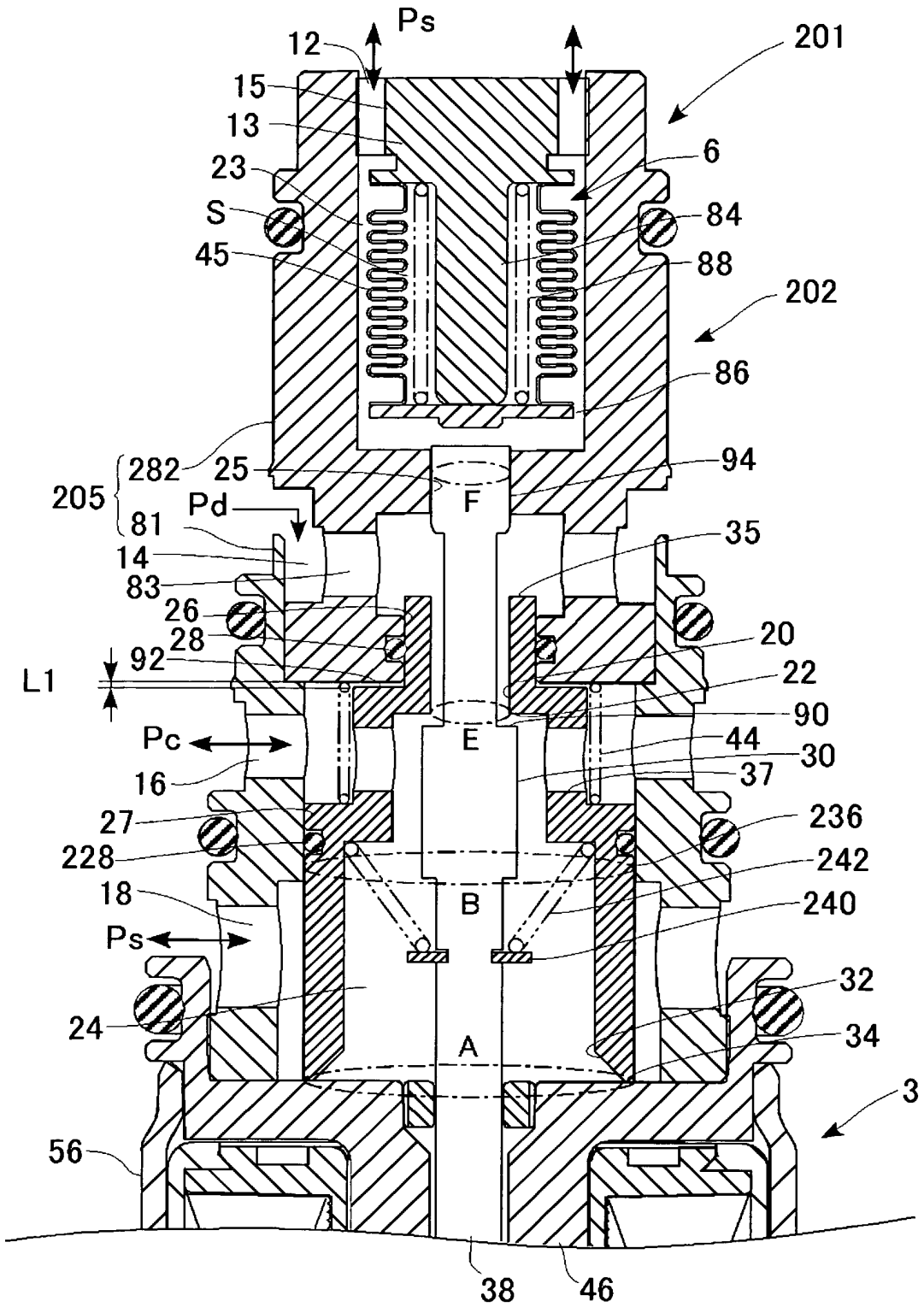
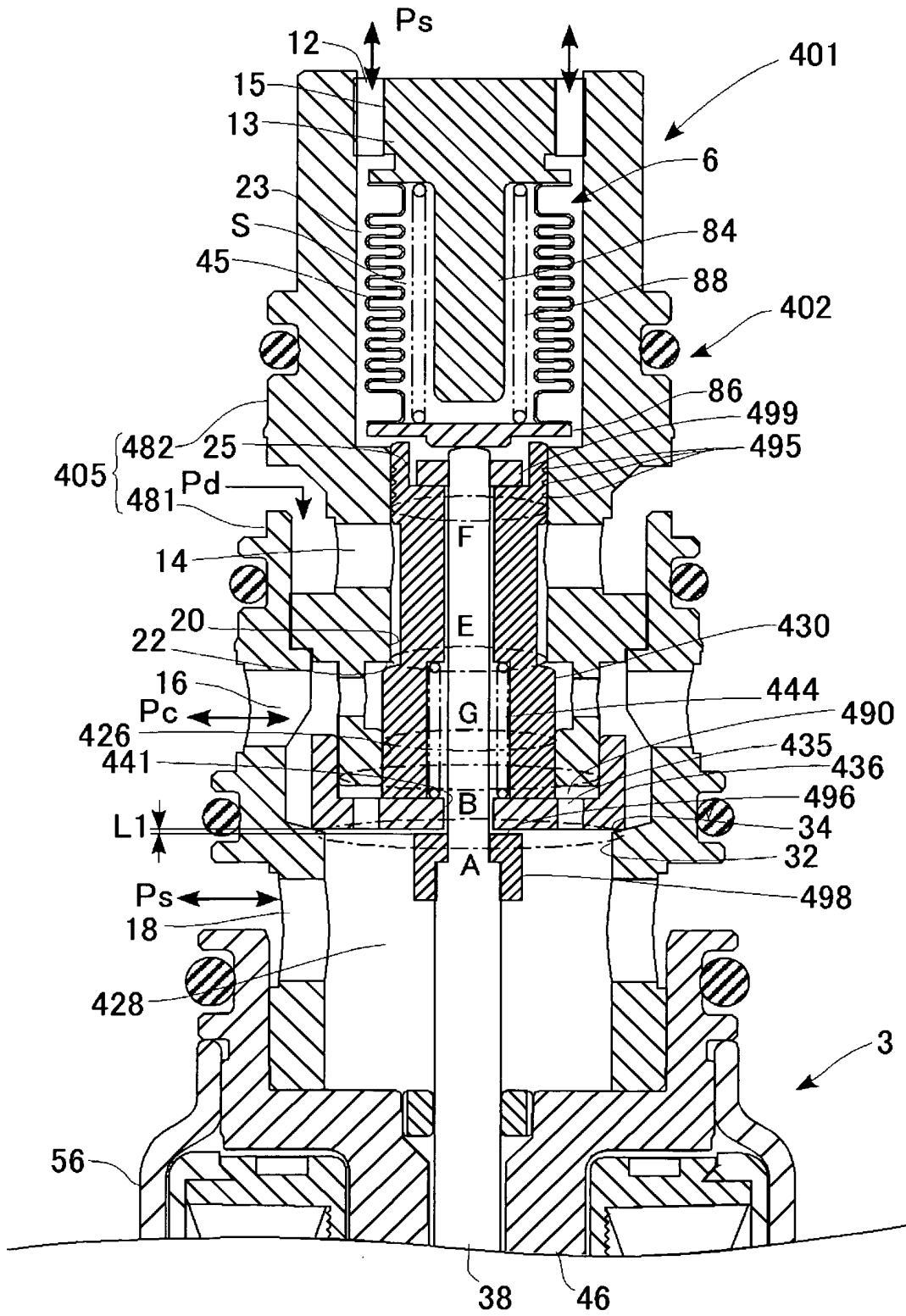

FIG. 7



REFERENCES CITED IN THE DESCRIPTION

This list of references cited by the applicant is for the reader's convenience only. It does not form part of the European patent document. Even though great care has been taken in compiling the references, errors or omissions cannot be excluded and the EPO disclaims all liability in this regard.

Patent documents cited in the description

- JP 2008240580 A [0007]