



(11) **EP 2 744 711 B9**

(12) **CORRECTED EUROPEAN PATENT SPECIFICATION**

(15) Correction information:
Corrected version no 1 (W1 B1)
Corrections, see
Description Paragraph(s) 2

(51) Int Cl.:
B65B 11/02 ^(2006.01) **B65B 11/04** ^(2006.01)
B61B 13/04 ^(2006.01) **F16M 11/18** ^(2006.01)

(48) Corrigendum issued on:
28.09.2016 Bulletin 2016/39

(86) International application number:
PCT/IB2012/054130

(45) Date of publication and mention
of the grant of the patent:
20.04.2016 Bulletin 2016/16

(87) International publication number:
WO 2013/024429 (21.02.2013 Gazette 2013/08)

(21) Application number: **12769735.7**

(22) Date of filing: **14.08.2012**

(54) **SYSTEM FOR MOVING OPERATING UNITS OF A WRAPPING MACHINE AND WRAPPING MACHINE**

SYSTEM ZUM BEWEGEN VON BEDIENEINHEITEN FÜR EINE VERPACKUNGSMASCHINE UND VERPACKUNGSMASCHINE

SYSTEME DE DEPLACEMENT D'UNITES DE FONCTIONNEMENT D'UNE MACHINE D'EMBALLAGE ET MACHINE D'EMBALLAGE

(84) Designated Contracting States:
**AL AT BE BG CH CY CZ DE DK EE ES FI FR GB
GR HR HU IE IS IT LI LT LU LV MC MK MT NL NO
PL PT RO RS SE SI SK SM TR**

(72) Inventors:
• **CERE', Mauro**
40050 Loiano (BO) (IT)
• **CASALBONI, Mirko**
47922 Rimini (RN) (IT)

(30) Priority: **16.08.2011 IT MO20110212**
16.08.2011 IT MO20110213

(74) Representative: **Cicconetti, Andrea et al**
Accapi S.R.L.
Via Garibaldi, 3
40124 Bologna (IT)

(43) Date of publication of application:
25.06.2014 Bulletin 2014/26

(73) Proprietor: **AETNA GROUP S.P.A.**
47826 Verucchio (RN) (IT)

(56) References cited:
DE-C1- 19 505 240 US-A1- 2005 193 687
US-A1- 2008 092 486 US-A1- 2008 229 707
US-B1- 6 553 746

EP 2 744 711 B9

Note: Within nine months of the publication of the mention of the grant of the European patent in the European Patent Bulletin, any person may give notice to the European Patent Office of opposition to that patent, in accordance with the Implementing Regulations. Notice of opposition shall not be deemed to have been filed until the opposition fee has been paid. (Art. 99(1) European Patent Convention).

Description

[0001] The invention relates to a movement system that is associable with a wrapping machine for moving operating units of the latter, for example, units for unwinding and prestretching the film, for gripping, cutting and welding the film, for labelling the load and/or the film, for printing the film, for inserting angular guards, etc. The invention also relates to a machine for wrapping a load with an extendible film of plastic material.

[0002] Known wrapping machines (a wrapping machine with a movement system according to the preamble of claim 1 is known from US 6 553 746 B1) comprise an unwinding unit that supports a reel from which the film of plastic material is unwound and possibly stretched to then be wrapped around the load in such a manner as to form a series of helical strips or bands, by virtue of the combination of movement in a vertical direction of the unwinding unit and of the reciprocal rotation between the latter and the load. The load typically consists of one or more products grouped and arranged on a pallet.

[0003] In wrapping machines provided with a rotating table supporting the load, the load is rotated around a vertical wrapping axis, whereas the unwinding unit is fixed to a carriage that is movable vertically with reciprocating motion along a fixed column.

[0004] In wrapping machines with a horizontal rotating ring or a rotating arm the load remains fixed during wrapping whilst the unwinding unit is rotated with respect to the latter around the vertical wrapping axis and is translated along the vertical wrapping axis. For this purpose, the unwinding unit is fixed to a ring, or to an arm, rotatably supported by a fixed structure of the machine and in such a manner as to rotate around the load.

[0005] In vertical rotating ring wrapping machines, the load is moved horizontally through the ring, whilst the unwinding unit rotates with the ring around a horizontal wrapping axis. The unwinding unit typically comprises a pair of prestretching rollers arranged for unwinding the film from the reel and optionally prestretching or elongating the film, and one or more idler rollers for diverting the film to the load. By appropriately adjusting the difference between the rotation speed of the prestretching rollers it is possible to prestretch by a defined quantity or percentage the film and vary the speed of unwinding of the film from the reel.

[0006] In addition to the unwinding unit and the corresponding movement means (ring, arm, carriage, etc) known wrapping machines comprise a plurality of operating units that are necessary for completing the wrapping process and for performing optional and accessory operations.

[0007] Such operating units comprise, for example, means that, at the end of wrapping, grasp the film, cut the film, stopping the two flaps thereby obtained and fixing by welding a first flap to the load, retaining a second flap, connected to the reel, to permit subsequent wrapping.

[0008] Optional operating units comprise, for example, means for applying labels or printing data to the film wrapped on the load and means for applying reinforcements and guards to the corners of the load.

5 **[0009]** The aforesaid operating units are necessarily fixed to the machine, adjacent to the load to be wrapped, generally fixed to load conveying and supporting means (roller conveyors, rotating table, etc.).

10 **[0010]** One drawback of the aforesaid operating units lies in the fact that they considerably increase the space occupied by the wrapping machine and set limits and constraints on the arrangement and positioning thereof in the environment or room in which the machine is installed. Further, as the aforesaid operating units are placed on the machine, they limit accessibility thereto, for example, for maintenance or repairs.

15 **[0011]** Often, the different operating units cannot be mounted together or can be mounted only with significant structural modifications and/or in operating positions that are not optimum with respect to the machine.

20 **[0012]** Units can also be defined as operating units that enable the reel of film to be replaced automatically or semi-automatically once it has finished or part or the entire unwinding unit to be replaced automatically or semi-automatically. Such operating units generally comprise supporting means or movement means suitable for receiving from the wrapping machine a reel or an unwinding unit to be replaced and for supplying a new reel or new unwinding unit to the aforesaid machine.

25 **[0013]** In addition to the aforesaid drawbacks, known operating units take a more or less long time to perform respective operations, which reduces the productivity of the wrapping machine. In effect, once the load has been wrapped by the film it cannot be moved and is thus extracted from the machine before completion of the expected operations, for example, gripping, cutting and welding, and before completion of possible optional operations.

30 **[0014]** Equally, the entry and wrapping of a subsequent load cannot occur until the working zone of the wrapping machine has been freed of the previous load.

35 **[0015]** Processes for replacing the reel or the wrapping unit can be completely automated but they nevertheless require significant execution time that reduces the productivity of the wrapping machine, which has to be stopped and cannot perform any operation.

40 **[0016]** One object of the invention is to improve known machines for wrapping a load with a film of extendible plastic material.

45 **[0017]** Another object is to carry out a movement system that is associable with a wrapping machine for moving operating units of the latter that simultaneously enables different operations and/or functions to be performed so as to increase the productivity of the machine compared with known wrapping machines.

50 **[0018]** A further object is to carry out a compact and flexible movement system that enables the space occupied by and dimensions of a wrapping machine to be

contained and limited with which the movement system is associated and/or included, ensuring at the same time optimum accessibility to the wrapping machine.

[0019] A further object is to provide a machine for wrapping a load with a film that enable optimising of the performance of operations on said load and/or on the film and/or of functions performed by/on the wrapping machine so as to increase the productivity of the wrapping machine.

[0020] In a first aspect of the invention a movement system according to claim 1 is provided.

[0021] In a second aspect a wrapping machine according to claims 14 is provided.

[0022] The invention can be better understood and implemented with reference to the attached drawings that illustrate some embodiments thereof by way of non-limiting example, in which:

Figure 1 is a perspective view of the movement system associated with a wrapping machine for moving operating units of the latter;

Figure 2 is a front view of the movement system and of the wrapping machine in Figure 1;

Figure 3 is a rear perspective view of the movement system in Figure 1;

Figure 4 is a perspective view of a shuttle of the system in Figure 3 in a retracted position, and, illustrated partially and in a dashed line, in an extended position;

Figure 5 is an enlarged detail of the movement system in Figure 3 that illustrates shuttle means supporting a first operating unit and a second operating unit of the wrapping machine;

Figure 6 is an enlarged detail in Figure 2 that illustrates shuttle means supporting the first operating unit and the second operating unit;

Figure 7 is a plan view of the shuttle means and of the operating units in Figure 6, the shuttle means being illustrated in two different operating configurations;

Figures 8 and 9 are front views of the system and of the wrapping machine in Figure 1 respectively in a first and a second operating configuration of a process of replacement of an unwinding unit mounted on the machine;

Figure 10 is a perspective view of the system and of the wrapping machine in Figure 1 in a first step of an operating process of gripping, cutting and welding the film at the end of wrapping.

Figures 11 and 12 are respectively frontal and top plan views of the system and of the wrapping machine in Figure 1 in a second step of the operating process of gripping, cutting and welding the film;

Figures 13 and 14 are respectively perspective and top plan views of the system and of the wrapping machine in Figure 1 in a third step of the operating process of gripping, cutting and welding the film;

Figure 15 is a plan view of the system and of the wrapping machine in Figure 1 in a fourth step of the

operating process of gripping, cutting and welding the film;

Figure 16 is a plan view of the system and of the wrapping machine in Figure 1 in one version of the operating process of gripping, cutting and welding the film;

Figure 17 is a perspective view of a version of the movement system in Figure 1 in a labelling process; Figure 18 is a plan view of the system and of the machine in Figure 17 in one version of the labelling process;

Figure 19 is a plan view of a version of a fourth labelling operating unit in Figure 18;

Figures 20 and 21 are respectively perspective and frontal views of another version of the movement system of the invention;

Figure 22 is a frontal view of a further version of the movement system of the invention;

Figure 23 is a perspective and frontal view of still another version of the movement system of the invention.

[0023] With reference to figures 1 to 7, there is illustrated a movement system 1 according to the invention, which is associable with a wrapping machine 100 for wrapping a load 70 with a film 4 of stretchable plastic material, for moving at least one operating unit that is suitable for performing operations on a load 70 that is to be wrapped or has already been wrapped and/or on the film and/or on the wrapping machine.

[0024] In the embodiment of the figures, the system 1 moves a plurality of operating units 30, 40, 50 arranged for performing distinct operations on the load 70, on the film, and on the wrapping machine. The operating units comprise, for example, a first operating unit 30 for gripping, cutting and welding the film, a second operating unit 40 for retaining the film and a third operating unit 50 for unwinding the film. The aforesaid operating units 30, 40, 50 are disclosed in detail further on in the description.

[0025] The wrapping machine 100 is, for example, of the rotating arm type and comprises a vertical arm 102 that is rotatable around a wrapping axis Z and slidably supports a wrapping carriage 101 to which a film 4 unwinding operating unit 50 is connected. The vertical arm 102 is fixed to a rotatable crosspiece 104 in such a manner as to rotate around the wrapping axis Z and the load 70. The carriages 101, the vertical arms 102 and the rotatable crosspiece 104 act as means for moving the third unwinding operating unit 50 (known hereinafter for the sake of convenience as unwinding unit 50). The unwinding unit 50 comprises at least one reel 3 of film 4, roller means 55, 56, 57 for unwinding and prestretching the film 4. In the example shown in the figures, the unwinding unit 50 further comprises a pair of motors 58 arranged for rotating respective prestretching rollers 55, 56.

[0026] As explained in greater detail later in the description, each unwinding unit 50 can be dismantled from the wrapping carriage 101 (for example after the film has

finished, has been damaged or has jammed) to be replaced by a respective replacement unwinding unit 50 (with a new and undamaged reel of film) by means of the movement system 1 of the invention. For this purpose, the wrapping carriage 101 is provided with a supporting unit 60 to and from which an unwinding unit 50 can be connected and disconnected.

[0027] The wrapping machine 100 is provided with conveying means 103 for supporting and moving the load 70 along an advancing direction V through the wrapping machine 100 and in particular through a working zone W of the wrapping machine 100 in which the film 4 is wrapped and one or more operations are performed on the load 70, on the film 4, and on the wrapping machine. The conveying means 103 enables a load 70 to be wrapped to be supplied to the machine 100 and a load 70 wrapped with the film 4 moved out of the machine. The conveying means 103 comprises, for example, one or more driving roller conveyors of known type.

[0028] The movement system 1 of the invention comprises shuttle means 11, 12, 21, 22 that is movable along a path P and is configured for supporting at least one operating unit of the wrapping machine 100. The shuttle means 11, 12, 21, 22 is slidably supported along the path P by guiding means 2.

[0029] The guiding means 2 traverses the working zone W of the wrapping machine 100.

[0030] In the embodiment illustrated in figures 1 to 7, the shuttle means 11, 12, 21, 22 houses and moves a first operating unit 30 for gripping, cutting and welding the film, a second operating unit 40 for retaining the film and a third operating unit 50 for unwinding the film. The first operating unit 30 and the second operating unit 40, at the end of load 70 wrapping, grip the film 4 unwound from the reel 3, cut said film 4, retaining the two free flaps obtained thereby, and fix by welding a first flap to the load 70 by retaining a second flap connected to the reel 3, to permit subsequent wrapping.

[0031] As will be explained better below in the description, the shuttle means 11, 12, 21, 22 and the conveying means 103 are drivable in a coordinated manner to enable the operating units to perform operations on the load 70 whilst the latter is moved along the advancing direction V. More precisely, the shuttle means 11, 12, 21, 22 and the conveying means 103 are drivable in a coordinated manner at the same speed to enable the first operating unit 30 to perform operations for gripping, cutting and welding the film on the moving load 70, in particular once the load 70 has been wrapped with the film.

[0032] The shuttle means 11, 12, 21, 22 is also movable along the path P between one or more operating positions, in which the operating units supported thereby can interact and perform operations on the load 70 and/or on the film and/or on the wrapping machine, and one or more non-operating positions in which the shuttle means 11, 12, 21, 22 and the corresponding operating units are outside the working zone W of the wrapping machine 100 in order not to interfere with the operation of the latter.

[0033] For this purpose, the shuttle means 11, 12, 21, 22 comprises driving means 19, 29 that is able to move the aforesaid shuttle means 11, 12, 21, 22 along the path P.

5 **[0034]** The shuttle means 11, 12 can further comprise braking means for stopping the aforesaid shuttle means in defined positions along the path P.

[0035] The shuttle means 11, 12, 21, 22 also comprises transferring means 15, 25 that is suitable for receiving and supporting respective operating units 30, 40, 50 and is movable along an operating direction T to enable the aforesaid operating units 30, 40, 50 to interact with and/or perform operations on the load 70 and/or on the film and/or on the wrapping machine.

10 **[0036]** The operating direction T is transverse, in particular orthogonal, to the path P. The operating direction T is further substantially horizontal.

[0037] The shuttle means 11, 12, 21, 22 comprises at least one shuttle that is provided with respective driving means for moving along the path P and is arranged for supporting and moving at least one respective operating unit by respective transferring means 15, 25. Preferably, the shuttle means comprises a plurality of shuttles 11, 12, 21, 22 each of which is arranged for receiving and moving at least one respective operating unit by respective transferring means 15, 25. The shuttles are connectable together to form at least one convoy of shuttles that are able to move independently along the path P.

20 **[0038]** For this purpose, each shuttle of the plurality of shuttles comprises hooking means 35 for connecting to at least one adjacent shuttle to form a convoy of shuttles.

[0039] The fixed hooking means 35 comprises, for example, screwable plates or brackets.

[0040] The shuttles can be provided with further hooking means 36 that are movable and selectively activatable to engage with and disengage from respective further hooking means 36 of an adjacent shuttle so as to connect together or disconnect the shuttles and respectively form or dismantle a convoy of shuttles.

30 **[0041]** In one embodiment of the movement system that is not illustrated the shuttle means comprises one or more shuttles, each of which is able to receive and move a plurality of operating units by respective transferring means. In particular, the shuttle means can comprise at least one shuttle provided with a plurality of transferring means for supporting and moving a respective plurality of operating units.

35 **[0042]** At least one shuttle of said plurality of shuttles is provided with respective driving means 19, 29 for moving the convoy with which it is associated.

[0043] In the embodiment illustrated purely by way of non-limiting example in figures 1 to 7, the shuttle means comprises two shuttles 12, 22 provided with respective driving means 19, 29, and defined for convenience as driving shuttles, and one or more shuttles 11, 21 devoid of driving means and defined for convenience as driven shuttles. A driving shuttle 12, 22 is connectable to one or more driven shuttles 11, 21 to form a convoy of shuttles

that is movable along the path P.

[0044] A convoy can also be formed by only one driving shuttle or by only one driven shuttle. The driven shuttles 11, 21 are provided with braking means for stopping and immobilising the latter in defined operating positions along the path P.

[0045] The braking means can also be provided for the driving shuttles 12, 22.

[0046] Each shuttle 11, 12 further comprises hooking means 35 for connecting to at least one adjacent shuttle to form a convoy of shuttles.

[0047] The fixed hooking means 35 comprises, for example, screwable plates or brackets.

[0048] Alternatively, the shuttles 21, 22 can comprise further movable hooking means 36 that are selectively activatable for engaging with or disengaging from respective further hooking means 36 of an adjacent shuttle 21, 22 so as to connect together or disconnect the shuttles and respectively form or dismantle a convoy of shuttles.

[0049] In the embodiment illustrated in figures 1 to 7, the shuttle means comprises a plurality of shuttles 11, 12, 21, 22 that are differently connected together in such a manner as to form two distinct convoys 5, 6 of shuttles.

[0050] In particular, said plurality of shuttles comprises a first driving shuttle 12 (i.e. shuttle provided with respective driving means) and a first driven shuttle 11 (i.e. devoid of respective driving means) that are connected together by hooking means 35 to form a first convoy 5, said first shuttles 11, 12 being arranged for receiving and moving an unwinding unit 50 of the film. The first driven shuttle 11 is empty for dismantling and receiving from the wrapping machine an unwinding unit 50 to be replaced, whereas the first driving shuttle 12 supports a replacement unwinding unit 50 to be mounted on the wrapping machine 100.

[0051] As will be explained better below in the description, the first convoy 5 is movable along the path P between a first operating position F1 (Figure 8) in which the first driven shuttle 11, by first transferring means 15 of the transferring means of the shuttle means, dismantles and receives from the wrapping machine 100 an unwinding unit 50 to be replaced, a second operating position F2 (Figure 9), in which the first driving shuttle 12, by respective first transferring means 15, transfers and mounts a new unwinding unit 50 on the wrapping machine 100 and a first non-operating position N1 (Figure 10) in which both the first shuttles 11, 12 are outside the working zone W of the wrapping machine 100 in order not to interfere with the operation of the latter.

[0052] In one version of the movement system of the invention, the first convoy 5 can comprise only one shuttle, for example the first driving shuttle, provided with empty transferring means for dismantling and receiving from the wrapping machine 100 an unwinding unit 50 to be replaced and further transferring means supporting a replacement unwinding unit 50 to be mounted on the wrapping machine 100.

[0053] The plurality of shuttles of the shuttle means

further comprises a second driven shuttle 21 (i.e. devoid of respective driving means) and a second driving shuttle 22 (i.e. provided with respective driving means) that form a second convoy 6. The second driving shuttle 22 supports a first operating unit 30 for gripping, cutting and welding the film, whilst the second driven shuttle 21 supports a second operating unit 40 for retaining the film 4.

[0054] As will be explained better below in the description, the second driving shuttle 22 is moved in a coordinated manner with the conveying means 103 at the same translation speed to enable the first operating unit 30 to perform operations for gripping, cutting and welding the film on the load 70 whilst the latter, wrapped with the film 4, is moved along the advancing direction V to exit the wrapping machine 100.

[0055] With particular reference to figure 3, the guiding means 2 comprises a closed section beam 53 to which the shuttle means 11, 12, 21, 22 is connected and along which the shuttle means 11, 12, 21, 22 can slide. The closed section beam 53 bestows the appropriate torsional stiffness on the guiding means 2, so as to ensure high precision in positioning of the shuttle means and thus of the operating units supported by the shuttle means.

[0056] The guiding means 2 is substantially rectilinear and arranged parallel to the advancing direction V, adjacent to the conveying means 103. In particular, as said above, the guiding means 2 traverses the working zone W of the wrapping machine 100 longitudinally. Alternatively, the guiding means 2 can be curved and comprise one or more rectilinear portions, for example, at the working zone W.

[0057] The guiding means 2 is further modular and consists of a plurality of beam sections or modules 53a that are connected together. The single modules 53a can be rectilinear, curvilinear and have different lengths.

[0058] In this manner it is possible to make easily, cheaply and quickly beams 53 of different length and shape according to the features of the wrapping machine and of the number and type of the operating units.

[0059] In one version of the system that is not illustrated, the guiding means 2 can comprise a pair of beams 53 arranged parallel and adjacent to opposite sides of the movement means 103 of the wrapping machine 100.

[0060] Each shuttle of the plurality of shuttles comprises substantially a carriage that is movable along the path P on the guiding means 2. The carriage is provided with wheels or sliding rollers and is configured for engaging and sliding on the guiding means 2. In particular, the wheels engage and slide inside rail means of the beam 53.

[0061] The carriage comprises hooking means for connecting to corresponding hooking means of an adjacent shuttle. The carriage further slidably supports respective transferring means arranged for supporting and moving a respective operating unit and comprising, in particular, a first transferring platform fixed by telescopic guides to end portions of the aforesaid carriage in such a manner as to be movable between a retracted position D1 and

an extended position D2 along the operating direction T. In the extended position D2 of the transferring means the operating unit that is supported by the latter is positioned in such a manner as to interact with and/or perform operations on the load and/or on the film and/or on the wrapping machine. In the retracted position D1 of the transferring means the operating unit is positioned in such a manner as not to interfere with the load and/or the film and/or the wrapping machine.

[0062] The transferring means is moved by actuating means.

[0063] The driving means associable with a shuttle of the plurality of shuttles includes, for example, an electric motor fixed to the carriage that rotates a gearwheel engaged with a rack fixed to the guiding means 2. Alternatively, the electric motor of the driving means can drive a pulley or a gearwheel that is able to couple with belt or chain fixed transmission systems of the guiding means 2 to move the shuttle.

[0064] Also alternatively, the driving means can comprise coupling means for coupling with belt or chain transmission means moved along the path P by a motor, for example an electric motor, associated with guiding means 2. The driving means can be activated or deactivated to connect or disconnect the shuttle to/from the aforesaid transmission systems to enable the shuttle to move or stop.

[0065] With particular reference to figure 4, the first driven shuttle 11 comprises a first carriage 13 provided with wheels or sliding rollers 14 and configured for engaging and sliding on the guiding means 2. In particular, the wheels 14 engage and slide inside rail means comprising a pair of rails 33 fixed to opposite sides of the beam 53.

[0066] The first carriage 13 comprises hooking means 35 for connecting to corresponding hooking means 35 of an adjacent first driven shuttle 11 or first driving shuttle 12.

[0067] To the first carriage 13 first transferring means 15 of the transferring means of the shuttle means is slidably connected that is intended for housing and supporting an operating unit, in the case in point an unwinding unit 50. The first transferring means substantially comprises a first transferring platform-15 fixed by telescopic guides 18 to end portions of the aforesaid first carriage 13, in such a manner as to be movable between a retracted position D 1 and an extended position D2 along the operating direction T.

[0068] First actuating means 16 is provided for moving the aforesaid first transferring platform 15 along the operating direction T. The first actuating means 16 includes, for example, a pneumatic or electric linear actuator.

[0069] The first transferring platform 5 is provided with stopping means 17 arranged for engaging with the unwinding unit 50 when the latter is positioned on the first transferring platform 15 and for preventing undesired movements thereof on a horizontal plane that is parallel to the aforesaid platform. The stopping means compris-

es, for example, a plurality of pins 17 that are suitable for engaging respective holes provided on a lower portion of the unwinding unit 50.

[0070] The first transferring means 15, as it is movable between the retracted position D1 and the extended position D2 along the operating direction T, enables the first driven shuttle 11 to selectively dismantle and receive an unwinding unit 50 to be replaced or to transfer and mount a replacement unwinding unit 50.

[0071] The first driving shuttle 12 is substantially identical to the first driven shuttle 11 from which it differs by the fact of comprising first driving means 19 of the driving means of the shuttle means that enables movement thereof along the guiding means 2. The first driving means 19 includes, for example, an electric motor fixed to the first carriage 13 that rotates a gearwheel engaged with a rack fixed to the guiding means 2.

[0072] Alternatively, the electric motor of the first driving means 19 can drive a pulley or gearwheel that is able to couple with belt or chain fixed transmission systems of the guiding means 2 so as to move the first driving shuttle 12.

[0073] Still alternatively, the first driving means of the first driving shuttle 12 can comprise coupling means for coupling with belt or chain transmission means moved along the path P by a motor, for example an electric motor, associated with the guiding means 2. The driving means can be activated or deactivated for connecting or disconnecting the first driving shuttle 12 to/from the aforesaid transmission systems and enabling the movement or stop thereof. The driving means can be activated or deactivated to connect or disconnect the shuttle to/from the aforesaid transmission systems to enable the shuttle to move or stop.

[0074] With particular reference to figures 5 to 7, the second driven shuttle 21 (i.e. devoid of driving means) is substantially similar to the first driven shuttle 11, from which it differs by the fact of comprising a second carriage 23 and second transferring means 25 of the transferring means of the shuttle means configured for housing and supporting a second operating unit 40 for retaining the film. Also in this case, the second carriage 23 is provided with wheels or sliding rollers for engaging and sliding inside the rails 33 of the guiding means 2.

[0075] The second carriage 23 comprises further hooking means 36 for reversibly connecting to corresponding further hooking means 36 of an adjacent second driven shuttle 21 or second driving shuttle 22.

[0076] The second transferring means 25 is slidably connected to the second carriage 23 by respective telescopic guides 18 and driven along the operating direction by second actuating means 26 between a respective retracted position D1 and a respective extended position D2. The second actuating means 26 includes, for example, a pneumatic or electric linear actuator.

[0077] In the respective extended position D2 the second operating unit 40 can interact with the load 70.

[0078] The second operating unit 40 for retaining the

film, of known type, substantially comprises a spring clip pliers 47 that is suitable for grasping and retaining an end flap of the film connected to the reel when the aforesaid film is cut at the end of the wrapping process.

[0079] The second driving shuttle 22 (i.e. provided with driving means) comprises a further second carriage 24 provided with further second transferring means 27, of the transferring means of the shuttle means, configured for housing and supporting a first operating unit 30 for gripping, cutting and welding the film. The further second transferring means 27 is slidably connected to the further second carriage 24 by respective telescopic guides 18 and is driven along the operating direction T by further second actuating means 28 between a respective retracted position D1 and a respective extended position D2. In the respective extended position D2 the first operating unit 30 can interact with the load 70. The further second carriage 24 is provided with second driving means 29 of the driving means of the shuttle means that enables the further second carriage 24 to be moved along the guiding means 2. The second driving means 29 comprises, for example, an electric motor that rotates a gearwheel engaged with a rack fixed to the guiding means 2. Alternatively, the electric motor of the second driving means 29 can drive a pulley or gearwheel that is able to couple with belt or chain fixed transmission systems of the guiding means 2 so as to move the second driving shuttle 22.

[0080] Still alternatively, the second driving means of the second driving shuttle 22 can comprise respective coupling means for coupling with belt or chain transmission systems moved along the path P by a motor, for example an electric motor, associated with the guiding means 2. The driving means can be activated or deactivated for connecting or disconnecting the second driving shuttle 22 to/from the aforesaid transmission systems and enabling the movement or stop thereof.

[0081] The first operating unit 30, of known type, comprises a contrasting lever 37, a cutting element 38 and a welding gun 39 that is able to grasp, cut and weld the film at the end of the wrapping process.

[0082] Alternatively, the first operating unit 30 can comprise only the contrasting lever 37 and the welding gun 39, the cutting element 38 being mounted in this case on the second operating unit 40.

[0083] As already shown, the shuttle means 11, 12, 21, 22 is movable along the path P between one or more operating positions in which the operating units supported thereby can interact and perform operations on the load 70 and/or on the film and/or on the wrapping machine 100 and one or more non-operating positions in which the shuttle means 11, 12 and the corresponding operating units are outside a working zone W of the wrapping machine 100 in order not to interfere with the operation of the latter.

[0084] A process for automatically replacing the unwinding unit 50 mounted on the wrapping machine 100 using the movement system 1 of the invention is disclosed below.

[0085] With reference to figures 8 and 9, in a first step of the replacement process, the shuttle means 11, 12, 21, 22 is moved in such a manner that the first convoy 5 of the first shuttles 11, 12 is arranged in a first operating position F1 and the second convoy 6 of the second shuttles 21, 22 is arranged in a second non-operating position N2 so that the first operating unit 30 and the second operating unit 40 do not hinder the aforesaid process.

[0086] In the second non-operating position N2 the first operating unit 30 and the second operating unit 40 are outside the working zone W and do not interfere with the operation of the wrapping machine.

[0087] In the first operating position F 1 the first convoy 5 is inside the working zone W and the empty first driven shuttle 11, is able to dismantle and receive the unwinding unit 50 to be replaced. In particular, the first transferring means 15 of the first driven shuttle 11 is arranged in the extended position D2 to receive the unwinding unit 50 to be replaced. For this purpose, the wrapping machine 100 is arranged in a replacement configuration G in which the rotating arm 102 is aligned with the first driven shuttle 11, and the carriage 101, to which the supporting unit 60 is fixed, is progressively lowered vertically in such a manner as to rest the unwinding unit 50 to be replaced on the transferring means 15 (Figure 8) of the first driven shuttle 11. The stopping means 17 engages the unwinding unit 50 to be replaced in such a manner that the transferring means 15, by moving along the operating direction T from the extended position D2 to the retracted position D1 disengages and dismantles the aforesaid unwinding unit 50 to be replaced from the supporting unit 60 fixed to the carriage 101.

[0088] As in the retracted position D1 of the first driven shuttle 11, the unwinding unit 50 to be replaced is detached and spaced away from the supporting unit 60, i.e. from the carriage 101, the first convoy 5 can be moved to the second operating position F2 in which the first driving shuttle 12 provided with the replacement unwinding unit 50 is at the supporting unit 60 (Figure 9). At this point, the transferring means 15 of the first driving shuttle 12 is moved from the retracted position D 1 to the extended position D2 to mount the replacement unwinding unit 50 on the supporting unit 60.

[0089] The carriage 101 is subsequently moved vertically along the vertical arm 102 in such a manner as to disengage the unwinding unit 50 that has just been mounted from the stopping means 17 of the first driving shuttle 12. The first convoy 5 of the shuttle means can then be moved along the path P, from the second operating position F2 to the first non-operating position N1, outside the working zone W to enable the wrapping machine to wrap the load (Figure 10).

[0090] During wrapping of the load, the second shuttles 21, 22 of the second convoy 6 can be moved from the second non-operating position N2, to a third operating position F3 in which the first operating unit 30 and the second operating unit 40 can interact with the load 70 and perform, stationary in the aforesaid third operating

position F3, operations for gripping, cutting and welding the film.

[0091] Owing to the movement system 1 of the invention it is thus possible to move the operating units to the respective operating positions adjacent to the load 70 and/or inside the working zone W only when they have to operate, maintaining on the other hand the aforesaid operating units in non-operating positions when they are not active. This enables the space occupied by the wrapping machine to be limited, accessibility thereto to be improved and permits mounting and correct operation of the different operating units. Figures 10 to 15 illustrate the method according to the invention for performing operations on a load 70, in particular wrapped with the film 4, by means of two operating units 30, 40 moved by the shuttle means 21, 22 in a coordinated manner with the load 70, in particular wrapped with the film, along the advancing direction V of the load and outside the wrapping machine.

[0092] In particular, a method is disclosed below for carrying out the process for gripping, cutting and welding the film, at the end of wrapping the load 70, whilst the latter is moved outside the wrapping machine by the conveying means 103.

[0093] In a first step of the process, the first shuttles 11, 12 of the first convoy 5 are arranged and stopped in the first non-operating position N1 in order not to interfere with the operation of the machine and in particular with the aforesaid process for gripping, cutting and welding the film.

[0094] The second shuttles 21, 22 of the second convoy 6 are on the other hand arranged in the third operating position F3, the respective second transferring means 25, 27 in the corresponding extended positions D2, to enable the operating units 30, 40 to perform the necessary operations on the film 4 (Figure 10).

[0095] When wrapping has almost been completed, the contrasting lever 37 of the first operating unit 30 is rotated to a vertical position so as to be wrapped with least one coil or band of film 4 dispensed by the unwinding unit 50.

[0096] In a second step of the process, with the load 70 correctly wrapped and the rotation of the vertical arm 102 stopped, the spring clip pliers 47 of the second operating unit 40 is driven to grasp and retain the film 4. At this point, the cutting element 38 of the first operating unit 30 cuts the film 4 and retains a first flap 4a of the film thereby obtained (tail of the film), the second flap 4b of the film being retained by the spring clip pliers 47 (Figures 11 and 12).

[0097] In a third step, immediately after execution of the cut, the conveying means 103 and the second driving shuttle 12 can be driven in such a manner as to move the load 70 and the first operating unit 30 in the advancing direction V at a substantially equal and constant speed.

[0098] As the spring clip pliers 37 has to retain the second flap 4b of film without further unwinding the film from the reel 3 of the unwinding unit 50, the second operating

unit 40 and the second driven shuttle 21 that supports second operating unit 40 remain stationary in the third operating position F3. The second driven shuttle 21, blocked by the respective braking means, is thus separated from the second driving shuttle 22 which on the other hand proceeds along the guiding means 2 in the advancing direction V. During the exiting of the load 70, the welding gun 39 welds, in cooperation with the contrasting lever 37, the first flap 4a to the film already wrapped on the load 70 (Figures 13 and 14).

[0099] Welding time varies according to the features of the plastic material of the film and/or the dimensions of the first flap 4a.

[0100] Whilst the load 70 wrapped with the film 4 is moved outside by the conveying means 103, a new load 70 to be wrapped can be introduced into the wrapping machine, progressively inside the working zone W.

[0101] In a fourth step, after welding has been completed, the contrasting lever 37 is disengaged from the film 4 wrapped on the load 70 and whilst the latter continues towards the exit of the machine 100 along the advancing direction V, the second driving shuttle 22, and the first operating unit 30 therewith, is moved in the direction opposite to the advancing direction (Figure 15) as far as the third operating position F3 to be hooked again to the second driven shuttle 21. In the return stroke, the transferring means 15 of the second driving shuttle 22 is returned to the retracted position D1.

[0102] It should be noted that during the welding time necessary to perform welding of the first flap 4a of film, the new load 70 to be wrapped can be positioned on the conveying means ready to be wrapped.

[0103] Alternatively, and in function of the duration of welding time, the wrapping cycle of the new load can start as soon as the wrapped load 70 has freed the working zone W.

[0104] In a further alternative, during welding time, the unwinding unit 50 replacement process can be run to replace the unwinding unit 50 mounted on the wrapping machine with a replacement unwinding unit 50 supported and moved by the first convoy 5 of the shuttle means.

[0105] In this manner, it is possible to run a welding process in so-called "masked" time, i.e. whilst the load 70 wrapped with the film 4 is moving and the wrapping machine performs other functions (receiving a new load 70, replacing the unwinding unit 50, etc.).

[0106] For the purposes of productivity, film welding time can thus be recovered during which in traditional machines the machine is stationary and inactive.

[0107] Film welding can also be performed with the wrapped load 70 stationary, after the latter has left the working zone W. In this case, as illustrated in figure 16, the second driving shuttle 22 is moved to a fourth operating position F4 in which the first operating unit 30 can perform welding of the first flap 4a of film.

[0108] Also in this case, whilst the load 70 wrapped with the film 4 is moved to the exit and the film is welded, a new load 70 to be wrapped can be introduced into the

machine in the working zone W.

[0109] It is thus possible to run a welding process in so-called "semi-masked" time, i.e. whilst the wrapped load 70 is stationary and the wrapping machine performs other functions (receiving new load 70 to be wrapped, replacing the unwinding unit 50, etc.).

[0110] Also in this case it is possible to increase the productivity of the wrapping machine by actively using film welding time that in traditional machines is a time during which the machine is stationary and inactive.

[0111] Figures 17 and 18 illustrate one version of the movement system of the invention that differs from the previously disclosed embodiment by the shuttle means that comprises a plurality of shuttles that include in addition to the first shuttles 11, 12 and to the second shuttles 21, 22 connected together to form respectively the first convoy 5 and the second convoy 6, a third shuttle 32 provided with respective driving means (defined for convenience as the third driving shuttle) and arranged for supporting a fourth operating unit 80. The third driving shuttle forms a third convoy 7 for supporting and moving the fourth operating unit 80 that is, for example, a labelling unit arranged for placing labels or identifying adhesives on the load 70 wrapped with the film.

[0112] The third driving shuttle 32 is substantially similar to the second driving shuttle 22 and comprises third transferring means 34, of the transferring means of the shuttle means, which is movable along the operating direction T between a respective retracted position D1 and a respective extended position D2 to enable the fourth labelling operating unit 80 to interact with the load or be spaced apart therefrom, respectively.

[0113] The operating procedure of the fourth labelling operating unit 80 is substantially identical to what was described for the second gripping, cutting and welding operating unit 40.

[0114] The procedure for applying the label to the wrapped load 70 can occur in "masked" time, i.e. by moving the third driving shuttle 32, and thus the fourth labelling operating unit 80, and the wrapped load 70 in a coordinated manner along the advancing direction V, as illustrated in Figure 17.

[0115] Alternatively, the procedure for applying the label to the wrapped load 70 can occur in "semi-masked" time, i.e. with the wrapped load 70 stationary and outside the working zone W. In this case, the third driving shuttle 32 is arranged in a fifth operating position F5 in which the fourth operating unit 80 can apply a label to the wrapped load 70 (Figure 18).

[0116] In both cases, whilst the label applying process is running, the wrapping machine 100 can perform other functions, in particular it can receive a new load 70 or replace the unwinding unit 50.

[0117] Figure 19 illustrates one version of the fourth labelling operating unit 80 that is installable on the shuttle means and is provided with an articulated arm 61 that is movable along the operating direction T. In this case, the third driving shuttle 32 is devoid of transferring means

that is movable along the operating direction T.

[0118] The movement system 1 of the invention can move other types of operating units that can operate in movement, i.e. can perform respective operations on the film and/or on the load whilst the latter is moved into or out of the wrapping machine, or can perform operations on the load and/or on the film and/or on the machine in established operating positions, inside or outside the working zone W of the wrapping machine W.

[0119] In addition to the operating units disclosed above, it is possible to provide, for example, a fifth operating unit for printing directly on the film wrapped on the load, one or more sixth operating units for applying angular guards etc to the load.

[0120] One advantage of the movement system 1 and of the wrapping machine 100 is thus that of being able to move the operating units into the respective operating positions, adjacent to the load and/or to the inside of the working zone W, only when they have to operate, vice versa maintaining the aforesaid operating units, when inactive, in non-operating positions, outside the working zone so as not to obstruct the operation of the machine. The guiding means 2 of the movement system 1 traverses the working zone W of the wrapping machine 100 parallel to an advancing direction V of the load and adjacent to the conveying means of the machine.

[0121] This not only enables the space occupied by the wrapping machine to be limited, so as to make the arrangement and the positioning of the latter more flexible and easier in the environment or room of installation but also enables the accessibility of the wrapping machine to be improved for routine maintenance (for example retooling of the operating units) or proactive maintenance.

[0122] Owing to the movement system 1, the mounting and correct operation of operating units is further possible that in traditional wrapping machines could not be mounted together or could be mounted only with significant structural modifications of the machine and/or in non-optimum operating positions.

[0123] Another advantage of the movement system 1 and of the wrapping machine 100 lies in the fact that the simultaneous movement of the operating units and of the load and/or the possibility of moving the operating units to different respective operating positions (inside and outside the working zone W) enable different operations and/or functions to be performed simultaneously so as to significantly increase the productivity of the machine with respect to known wrapping machines. In particular, it is possible to perform operations (film welding, labelling, printing) to an exiting load wrapped with the film (with the load moving or stationary outside the working zone) whilst a new load is introduced into the machine, and possible wrapped, or whilst further operations (for example replacing the unwinding unit) are performed on the machine.

[0124] It should be noted that if the operations have been performed by moving the operating units and the

load along the advancing direction V with a coordinated motion, at the same speed, there is no load transfer time in which the wrapping machine is inactive and does not perform operations, this enabling the performance of operations and/or functions to be optimised and the productivity of the wrapping machine to be increased still further. Finally, the movement system 1 for moving the operating units constitutes an integrated system that enables the wrapping machine to perform wrapping operations (gripping, cutting and welding the film) and optional operations (replacing the unwinding unit, labelling, printing, inserting guards) in a completely automated manner without requiring the invention of operators.

[0125] Figures 20 and 21 illustrate another version of the movement system 1 of the invention that differs from the embodiment previously disclosed and illustrated in figures 1 to 6 by the shuttle means that comprises a plurality of shuttles that include, for example, one or more fourth shuttles, for example two, devoid of driving means (defined for convenience as fourth driven shuttles 41) and a shuttle provided with respective driving means, but devoid of transferring means for supporting an operating unit (defined for convenience as a driving shuttle 42). The fourth driven shuttles 41 and the driving shuttle 42 are movable along the guiding means 2 and connected together so as to form a fourth convoy 8 of shuttles. Each fourth driven shuttle 41 is arranged for supporting and moving at least one respective further unwinding unit 450. The latter comprises a reel 3 of film and roller means 55, 56, 57 and is in this case devoid of driving motors of the prestretching rollers provided on the wrapping machine.

[0126] The fourth driven shuttle 41 comprises a fourth carriage 43, provided with sliding wheels and configured for engaging and sliding on the guiding means. To the fourth carriage 43 fourth transferring means 45 of the transferring means of the shuttle means is connected that is suitable for housing and supporting an unwinding unit 50. The fourth transferring means 45 comprises a fourth transferring platform fixed by telescopic guides 18 to end portions of the aforesaid fourth carriage 43, in such a manner as to be movable between a respective retracted position D1 and a respective extended position D2 along the operating direction T, driven by linear actuating means.

[0127] The fourth transferring means 45 is provided with stopping means 17 suitable for engaging with the further unwinding unit 450 when the latter is positioned on the platform so as to prevent undesired movements thereof on a horizontal plane.

[0128] The fourth driven shuttles 41 are provided with braking means for stopping and locking the latter in defined operating positions along the guiding means 2.

[0129] The driving shuttle 42 comprises a fifth carriage 44 to which third driving means 49 of the driving means of the shuttle means is fixed, comprising, for example, a respective electric motor that rotates a gearwheel engaged on a rack fixed to the guiding means 2. Alternatively,

the electric motor of the third driving means 49 can drive a pulley or a gearwheel that is able to couple with a belt or chain fixed transmission systems of the guiding means 2 to move the driving shuttle 42.

[0130] Still alternatively, the driving means of the driving shuttle 42 can comprise respective coupling means for coupling with belt or chain transmission systems moved along the path P by a motor, for example an electric motor, associated with the guiding means 2. The driving means can be activated or deactivated for connecting or disconnecting the driving shuttle 42 to/from the aforesaid transmission systems and enabling the movement or stop thereof.

[0131] As the driving shuttle 42 is devoid of transferring means, it supports no operating unit, but is intended only for moving the fourth convoy 8, i.e. the fourth driven shuttles 41 to which it is reversibly hooked. For this purpose, the driving shuttle 42 and the fourth driven shuttles 41 are provided with respective further hooking means 36 for mutual reversible connecting.

[0132] It should be noted that the driving shuttle 42 can also be used for moving the convoys 5, 6 of the previously disclosed shuttles 11, 12, 21, 22. In this case the convoys 5, 6 can comprise only first driven shuttles 11 and second driven shuttles 21, respectively, in addition to respective driving shuttles 42.

[0133] Figure 22 illustrates a further version of the movement system 1 of the invention that differs from the embodiments previously disclosed and illustrated by the shuttle means that comprises a plurality of shuttles that include first driven shuttles 11 and second driven shuttles 21, connected to form respectively a first convoy 5 and a second convoy 6, and a shuttle provided with respective driving means, but devoid of transferring means for supporting an operating unit (defined for convenience as a further driving shuttle 52), the latter being able to slide freely along the guiding means 2 to connect and move a given convoy 5, 6 or a determined shuttle of the convoy. It should be noted that each convoy can be formed of one or more of said first driven shuttles 11 and/or second driven shuttles 21.

[0134] The shuttles of the plurality of shuttles can also form a single convoy.

[0135] The further driving shuttle 52 is slidably movable along a further rail 33' of the rail means of the guiding means 2, which is fixed laterally to the beam 53 below one of the two rails 33 along which the first driven shuttles 11 and the second driven shuttles 12 slide. The further driving shuttle 52 is configured in such a manner as to pass underneath the driven shuttles 11, 21 from one end to the other of the beam 53 so as to be able to hook the shuttle 11, 21 which supports the operating unit 30, 40, 50 to be moved with the load 70 or to be moved to a set operating or non-operating position.

[0136] The further driving shuttle 52 comprises a further fifth carriage 54 to which the third driving means 49 is fixed.

[0137] The further driving shuttle 52 further comprises

another respective hooking means that is not illustrated that is activatable or deactivatable to enable said further driving shuttle 52 to be hooked to or unhooked from a driven shuttle 11,21.

[0138] This version of the movement system 1 thus enables only driven shuttles 11, 21 (i.e. shuttles devoid of driving means) to be used to support the operating units 30, 40, 50, delegating to the further driving shuttle 52 (i.e. provided with driving means but devoid of transferring means for supporting an operating unit) the task of moving the aforesaid operating units along the guiding means 2.

[0139] Figure 23 illustrates still another version of the movement system that differs from the embodiment disclosed above and shown in figures 1 to 7 by the shuttle means, which comprises only one shuttle, in particular a fifth shuttle 111, that forms a respective convoy and comprises transferring means 115 and further transferring means 125 arranged for receiving and supporting respective operating units (that are not illustrated) and are movable, independently and separated from one another, along the operating direction T for moving said operating units towards or away from said load 70 and/or said film and/or said wrapping machine. In particular, the transferring means 115 and further transferring means 125 are arranged for moving along the operating direction T the aforesaid operating units and enabling the latter to interact and/or perform operations on the load 70 and/or on the film and/or on the wrapping machine.

[0140] The fifth shuttle 111 comprises a fifth carriage 113 that is movable along the path P, is slidably engaged with the guiding means 2 and is arranged for slidably supporting the transferring means and the further transferring means respectively comprising a transferring platform 115 and a further transferring platform 125. The transferring platform 115 and the further transferring platform 125 are fixed by corresponding telescopic guides 18 to end portions of the aforesaid carriage 113, in such a manner as to be movable between a respective retracted position D1 and a respective extended position D2 along the operating direction T. In the respective extended positions D2 of the transferring means 115, 125 the operating units supported by the latter can interact and/or perform operations on the load and/or on the film and/or on the wrapping machine; in the respective retracted positions D1 of the transferring means 115, 125 the operating units are positioned in such a manner as not to interfere with the load and/or the film and/or the wrapping machine.

[0141] Respective third actuating means 116 is provided for moving independently and separately the aforesaid transferring platform 115, 125 along the operating direction T. The third actuating means 116 includes, for example, pneumatic or electric linear actuators.

[0142] The fifth shuttle 111 is moved along the path P by fifth driving means 119 of the driving means of the shuttle means, in such a manner as to move the operating units between the respective operating positions, in

which the operating units can perform operations on said load and/or on said film and/or can interact with the wrapping machine, and the respective non-operating positions in which the operating units are outside a working zone of the wrapping machine 100 in order not to interfere with operation thereof. Alternatively, the fifth shuttle 111 can be a driven shuttle that is movable along the guiding means 2 by one of the driving shuttles disclosed above.

[0143] The fifth shuttle 111 alone enables two operating units to be positioned in respective operating positions along the path P in such a manner that they can perform operations on the load 70 and/or on the film and/or on the wrapping machine 100.

[0144] In a further version of the movement system that is not shown in the figures, the shuttle means comprises only one shuttle provided with a plurality of transferring means that is suitable for supporting and moving independently a plurality of respective operating units along the operating direction T. In particular, in this version the shuttle comprises three or more transferring platforms fixed by corresponding telescopic guides to the carriage of the shuttle and driven by respective actuating means.

[0145] The movement system 1 has been illustrated and disclosed by way of non-limiting example in association with a rotating-arm wrapping machine, but can be associated with, used and included in a wrapping machine with a double rotating arm, a wrapping machine with a vertical-axis or horizontal-axis rotating ring, a wrapping machine with a rotating table.

Claims

1. Movement system that is associable with a wrapping machine (100) for wrapping a load (70) with a film (4) comprising at least one operating unit (30, 40, 50, 80) for performing operations on said load (70) and/or on said film (4), said system comprising shuttle means (11, 12, 21, 22; 32; 41, 42; 52; 111) that is movable for supporting and moving at least said operating unit (30, 40, 50, 80) along a path (P) at least between an operating position (F1, F2, F3, F4, F5), in which said operating unit (30, 40, 50, 80) can perform operations on said load (70) and/or on said film (4) and/or can interact with said wrapping machine (100), and a non-operating position (N1; N2) in which said operating unit (30, 40, 50, 80) is outside a working zone (W) of said wrapping machine (100) in order not to interfere with the operation of the latter, said system being **characterised in that** said shuttle means comprises a plurality of shuttles (11, 12, 21, 22; 32; 41, 42; 52; 111) that are connectable together to form at least one convoy (5, 6, 7, 8) of shuttles.
2. System according to claim 1, wherein said shuttle means (11, 12, 21, 22; 32; 41, 42; 52; 111) comprises driving means (19, 29; 49; 119) for moving said shut-

tle means (11, 12, 21, 22; 32; 41, 42; 52; 111) along said path (P).

3. System according to claim 1 or 2, wherein said shuttle means (11, 12, 21, 22; 32; 41, 42; 52; 111) comprises braking means for stopping said shuttle means (11, 12, 21, 22; 32; 41, 42; 52; 111) in said operating positions (F1, F2, F3, F4, F5) and/or in said non-operating positions (N1, N2) along said path (P).
4. System according to any preceding claim, wherein said plurality of shuttles (11, 12, 21, 22; 32; 41, 42; 52; 111.) comprises at least one shuttle provided with respective driving means (19, 29; 119) for moving said shuttle along said path (P) and arranged for supporting at least one operating unit (30, 40, 50, 80).
5. System according to any preceding claim, wherein each shuttle of said plurality of shuttles (11, 12, 21, 22; 32; 41, 42; 52; 111) comprises hooking means (35, 36) that is arranged for engaging or disengaging from respective hooking means (35, 36) of an adjacent shuttle (11, 12, 21, 22; 32; 41, 42; 52; 111) so as to mutually connect or disconnect said shuttles.
6. System according to any preceding claim, wherein said plurality of shuttles comprises at least one shuttle (12, 22; 32; 42; 52; 111) provided with respective driving means (19, 29; 49; 119) for moving said convoy (5, 6, 7, 8) of shuttles along said path (P).
7. System according to any preceding claim, wherein each shuttle of said plurality of shuttles is arranged for supporting at least one respective operating unit (30, 40, 50, 80).
8. System according to any preceding claim, wherein said shuttle means comprises a plurality of shuttles arranged for supporting respective operating units (30, 40, 50) and at least one shuttle provided with respective driving means (49) and arranged for hooking a shuttle of said plurality of shuttles for moving at least the aforesaid shuttle along said path (P).
9. System according to any preceding claim, comprising guiding means (2) for slidably supporting said shuttle means (11, 12, 21, 22; 32; 41, 42; 52; 111) along said path (P), in particular said guiding means (2) traversing a working zone (W) of said wrapping machine (100).
10. System according to claim 9, wherein said guiding means (2) comprises at least one beam (53) that slidably supports said shuttle means (11, 12, 21, 22; 32; 41, 42; 52; 111) by means of rail means (33, 33'), in particular said beam (53) having a closed section and comprising a plurality of modules (53a) that are

mutually connectable.

11. System according to claim 9 or 10, wherein said guiding means (2) is substantially rectilinear and parallel to said advancing direction (V), in particular adjacent to said conveying means (103).
12. System according to any preceding claim, wherein said shuttle means (11, 12, 21, 22; 32; 41, 42; 52; 111) comprises transferring means (15, 25, 27; 34; 45; 115, 125) for receiving and supporting at least one respective operating unit (30, 40, 50, 80), said transferring means (15, 25, 27; 34; 45; 115; 125) being movable along a substantially horizontal operating direction (T) for moving said respective operating unit (30, 40, 50, 80) towards and/or away from said load (70) and/or said film (4) and/or said wrapping machine (100).
13. System according to any preceding claim, wherein said operating unit comprises one amongst: first operating unit (30) for gripping, cutting and welding the film, second operating unit (40) for retaining the film, third operating unit (50) for unwinding the film, fourth operating unit (80) for labeling, fifth operating unit for printing, sixth operating unit for inserting load guards.
14. Machine for wrapping a load (70) with a film (4) comprising at least one operating unit (30, 40, 50, 80) for performing operations on said load (70) and/or on said film (4), **characterised in that** it comprises a movement system (1) according to any one of claims 1 to 13.

Patentansprüche

1. Bewegungssystem, das mit einer Verpackungsmaschine (100) zum Verpacken einer Ladung (70) mit einem Film (4) verbindbar ist, die mindestens eine Betriebseinheit (30, 40, 50, 80) zum Durchführen von Operationen an der Ladung (70) und/oder dem Film (4) umfasst, wobei das System eine Transportereinrichtung (11, 12, 21, 22; 32; 41, 42; 52; 111) umfasst, die zum Abstützen und Bewegen zumindest der Betriebseinheit (30, 40, 50, 80) entlang eines Weges (P) zumindest zwischen einer Betriebsposition (F1, F2, F3, F4, F5), in der die Betriebseinheit (30, 40, 50, 80) Operationen an der Ladung (70) und/oder dem Film (4) durchführen kann und/oder mit der Verpackungsmaschine (100) zusammenwirken kann, und einer Nicht-Betriebs-Position (N1; N2), in der die Betriebseinheit (30, 40, 50, 80) sich außerhalb einer Arbeitszone (W) der Verpackungsmaschine (100) befindet, um den Betrieb der letzteren nicht zu stören, beweglich ist, wobei das System **dadurch gekennzeichnet ist, dass** die Transportereinrichtung eine Vielzahl von Transportern (11, 12, 21, 22; 32;

- 41, 42; 52; 111) umfasst, die miteinander verbindbar sind, um mindestens eine Kolonne (5, 6, 7, 8) von Transportern zu bilden.
2. System nach Anspruch 1, wobei die Transportereinrichtung (11, 12, 21, 22; 32; 41, 42; 52; 111) eine Antriebseinrichtung (19, 29; 49; 119) zum Bewegen der Transportereinrichtung (11, 12, 21, 22; 32; 41, 42; 52; 111) entlang des Weges (P) umfasst.
 3. System nach Anspruch 1 oder 2, wobei die Transportereinrichtung (11, 12, 21, 22; 32; 41, 42; 52; 111) eine Bremseinrichtung zum Stoppen der Transportereinrichtung (11, 12, 21, 22; 32; 41, 42; 52; 111) in den Betriebspositionen (F1, F2, F3, F4, F5) und/oder in den Nicht-Betriebs-Positionen (N1, N2) entlang des Weges (P) umfasst.
 4. System nach einem vorhergehenden Anspruch, wobei die Vielzahl von Transportern (11, 12, 21, 22; 32; 41, 42; 52; 111) mindestens einen Transporter umfasst, der mit einer jeweiligen Antriebseinrichtung (19; 29; 119) zum Bewegen des Transporters entlang des Weges (P) versehen ist und zum Abstützen mindestens einer Betriebseinheit (30, 40, 50, 80) angeordnet ist.
 5. System nach einem vorhergehenden Anspruch, wobei jeder Transporter der Vielzahl von Transportern (11, 12, 21, 22; 32; 41, 42; 52; 111) eine Einhakeinrichtung (35, 36) umfasst, die zum Eingriff mit oder Lösen von einer jeweiligen Einhakeinrichtung (35, 36) eines benachbarten Transporters (11, 12, 21, 22; 32; 41, 42; 52; 111) angeordnet ist, um die Transporter miteinander zu verbinden oder voneinander zu trennen.
 6. System nach einem vorhergehenden Anspruch, wobei die Vielzahl von Transportern mindestens einen Transporter (12, 22; 32; 42; 52; 111) umfasst, der mit jeweiligen Antriebseinrichtungen (19, 29; 49; 119) zum Bewegen der Kolonne (5, 6, 7, 8) von Transportern entlang des Weges (P) versehen ist.
 7. System nach einem vorhergehenden Anspruch, wobei jeder Transporter der Vielzahl von Transportern zum Abstützen mindestens einer jeweiligen Betriebseinheit (30, 40, 50, 80) angeordnet ist.
 8. System nach einem vorhergehenden Anspruch, wobei die Transportereinrichtung eine Vielzahl von Transportern umfasst, die zum Abstützen von jeweiligen Betriebseinheiten (30, 40, 50) angeordnet sind, und mindestens ein Transporter mit einer jeweiligen Antriebseinrichtung (49) versehen ist und zum Einhängen eines Transporters der Vielzahl von Transportern zum Bewegen zumindest des vorstehend genannten Transporters entlang des Weges (P) angeordnet ist.
 9. System nach einem vorhergehenden Anspruch, das eine Führungseinrichtung (2) zum verschiebbaren Abstützen der Transportereinrichtung (11, 12, 21, 22; 32; 41, 42; 52; 111) entlang des Weges (P) umfasst, wobei insbesondere die Führungseinrichtung (2) eine Arbeitszone (W) der Verpackungsmaschine (100) durchquert.
 10. System nach Anspruch 9, wobei die Führungseinrichtung (2) mindestens einen Balken (53) umfasst, der die Transportereinrichtung (11, 12, 21, 22; 32; 41, 42; 52; 111) mittels Schieneneinrichtungen (33, 33') verschiebbar abstützt, wobei insbesondere der Balken (53) einen geschlossenen Querschnitt aufweist und eine Vielzahl von Modulen (53a) umfasst, die miteinander verbindbar sind.
 11. System nach Anspruch 9 oder 10, wobei die Führungseinrichtung (2) im Wesentlichen geradlinig und zur Vorschubrichtung (V) parallel, insbesondere zur Fördereinrichtung (103) benachbart ist.
 12. System nach einem vorhergehenden Anspruch, wobei die Transportereinrichtung (11, 12, 21, 22; 32; 41, 42; 52; 111) eine Überführungseinrichtung (15, 25, 27; 34, 45; 115, 125) zum Aufnehmen und Abstützen mindestens einer jeweiligen Betriebseinheit (30, 40, 50, 80) umfasst, wobei die Überführungseinrichtung (15, 25, 27; 34, 45; 115, 125) entlang einer im Wesentlichen horizontalen Betriebsrichtung (T) zum Bewegen der jeweiligen Betriebseinheit (30, 40, 50, 80) zu der Ladung (70) und/oder dem Film (4) und/oder der Verpackungsmaschine (100) hin und von diesen weg beweglich ist.
 13. System nach einem vorhergehenden Anspruch, wobei die Betriebseinheit eine umfasst aus: einer ersten Betriebseinheit (30) zum Greifen, Schneiden und Schweißen des Films, einer zweiten Betriebseinheit (40) zum Festhalten des Films, einer dritten Betriebseinheit (50) zum Abwickeln des Films, einer vierten Betriebseinheit (80) zum Beschriften, einer fünften Betriebseinheit zum Bedrucken, einer sechsten Betriebseinheit zum Einfügen von Ladungsschutzvorrichtungen.
 14. Maschine zum Verpacken einer Ladung (70) mit einem Film (4), die mindestens eine Betriebseinheit (30, 40, 50, 80) zum Durchführen von Operationen an der Ladung (70) und/oder dem Film (4) umfasst, **dadurch gekennzeichnet, dass** sie ein Bewegungssystem (1) nach einem der Ansprüche 1 bis 13 umfasst.

Revendications

1. Système de déplacement qui est associable à une machine d'emballage (100) pour emballer une charge (70) avec un film (4) comprenant au moins une unité opérationnelle (30, 40, 50, 80) pour réaliser des opérations sur ladite charge (70) et/ou sur ledit film (4), ledit système comprenant des moyens à navettes (11, 12, 21, 22 ; 32 ; 41, 42 ; 52 ; 111) qui sont mobiles pour supporter et déplacer au moins ladite unité opérationnelle (30, 40, 50, 80) le long d'un trajet (P) au moins entre une position opérationnelle (F1, F2, F3, F4, F5), dans laquelle ladite unité opérationnelle (30, 40, 50, 80) peut réaliser des opérations sur ladite charge (70) et/ou sur ledit film (4) et/ou peut interagir avec ladite machine d'emballage (100), et une position non opérationnelle (N1 ; N2) dans laquelle ladite unité opérationnelle (30, 40, 50, 80) est en dehors d'une zone de travail (W) de ladite machine d'emballage (100) afin de ne pas interférer avec le fonctionnement de cette dernière, ledit système étant **caractérisé en ce que** lesdits moyens à navettes comprennent une pluralité de navettes (11, 12, 21, 22 ; 32 ; 41, 42 ; 52 ; 111) qui sont raccordable ensemble pour former au moins un convoi (5, 6, 7, 8) de navettes.
2. Système selon la revendication 1, dans lequel lesdits moyens à navettes (11, 12, 21, 22 ; 32 ; 41, 42 ; 52 ; 111) comprennent des moyens d'entraînement (19, 29 ; 49 ; 119) pour déplacer lesdits moyens à navettes (11, 12, 21, 22 ; 32 ; 41, 42 ; 52 ; 111) le long dudit trajet (P).
3. Système selon la revendication 1 ou 2, dans lequel lesdits moyens à navettes (11, 12, 21, 22 ; 32 ; 41, 42 ; 52 ; 111) comprennent des moyens de freinage pour arrêter lesdits moyens à navettes (11, 12, 21, 22 ; 32 ; 41, 42 ; 52 ; 111) dans lesdites positions opérationnelles (F1, F2, F3, F4, F5) et/ou dans lesdites positions non opérationnelles (N1, N2) le long dudit trajet (P).
4. Système selon une quelconque revendication précédente, dans lequel ladite pluralité de navettes (11, 12, 21, 22 ; 32 ; 41, 42 ; 52 ; 111) comprend au moins une navette pourvue de moyens d'entraînement respectifs (19, 29 ; 119) pour déplacer ladite navette le long dudit trajet (P) et agencée pour supporter au moins une unité opérationnelle (30, 40, 50, 80).
5. Système selon une quelconque revendication précédente, dans lequel chaque navette parmi ladite pluralité de navettes (11, 12, 21, 22 ; 32 ; 41, 42 ; 52 ; 111) comprend des moyens d'accrochage (35, 36) qui sont agencés pour entrer en prise avec ou se séparer de moyens d'accrochage respectifs (35, 36) d'une navette adjacente (11, 12, 21, 22 ; 32 ; 41, 42 ; 52 ; 111) afin de raccorder ou de disjoindre mutuellement lesdites navettes.
6. Système selon une quelconque revendication précédente, dans lequel ladite pluralité de navettes comprend au moins une navette (12, 22 ; 32 ; 42 ; 52 ; 111) pourvue de moyens d'entraînement respectifs (19, 29 ; 49 ; 119) pour déplacer ledit convoi (5, 6, 7, 8) de navettes le long dudit trajet (P).
7. Système selon une quelconque revendication précédente, dans lequel chaque navette parmi ladite pluralité de navettes est agencée pour supporter au moins une unité opérationnelle respective (30, 40, 50, 80).
8. Système selon une quelconque revendication précédente, dans lequel lesdits moyens à navettes comprennent une pluralité de navettes agencées pour supporter des unités opérationnelles respectives (30, 40, 50) et au moins une navette pourvue de moyens d'entraînement respectifs (49) et agencée pour accrocher une navette parmi ladite pluralité de navettes pour déplacer au moins la navette susdite le long dudit trajet (P).
9. Système selon une quelconque revendication précédente, comprenant des moyens de guidage (2) pour supporter de façon coulissante lesdits moyens à navettes (11, 12, 21, 22 ; 32 ; 41, 42 ; 52 ; 111) le long dudit trajet (P), en particulier lesdits moyens de guidage (2) traversant une zone de travail (W) de ladite machine d'emballage (100).
10. Système selon la revendication 9, dans lequel lesdits moyens de guidage (2) comprennent au moins une poutre (53) qui supporte de façon coulissante lesdits moyens à navettes (11, 12, 21, 22 ; 32 ; 41, 42 ; 52 ; 111) au moyen de moyens à rail (33, 33'), en particulier ladite poutre (53) comportant une section fermée et comprenant une pluralité de modules (53a) qui sont mutuellement raccordable.
11. Système selon la revendication 9 ou 10, dans lequel lesdits moyens de guidage (2) sont sensiblement rectilignes et parallèles à ladite direction d'avance (V), en particulier adjacents auxdits moyens de transport (103).
12. Système selon une quelconque revendication précédente, dans lequel lesdits moyens à navettes (11, 12, 21, 22 ; 32 ; 41, 42 ; 52 ; 111) comprennent des moyens de transfert (15, 25, 27 ; 34 ; 45 ; 115, 125) pour recevoir et supporter au moins une unité opérationnelle respective (30, 40, 50, 80), lesdits moyens de transfert (15, 25, 27 ; 34 ; 45 ; 115 ; 125) étant mobiles le long d'une direction opérationnelle sensiblement horizontale (T) pour déplacer ladite

unité opérationnelle respective (30, 40, 50, 80) pour la rapprocher et/ou l'éloigner de ladite charge (70) et/ou dudit film (4) et/ou de ladite machine d'emballage (100).

5

13. Système selon une quelconque revendication précédente, dans lequel ladite unité opérationnelle comprend l'une parmi : une première unité opérationnelle (30) pour saisir, couper et souder le film, une deuxième unité opérationnelle (40) pour retenir le film, une troisième unité opérationnelle (50) pour dérouler le film, une quatrième unité opérationnelle (80) pour étiqueter, une cinquième unité opérationnelle pour imprimer, une sixième unité opérationnelle pour insérer des organes de protection de charge.

10

15

14. Machine pour emballer une charge (70) avec un film (4) comprenant au moins une unité opérationnelle (30, 40, 50, 80) pour réaliser des opérations sur ladite charge (70) et/ou sur ledit film (4), **caractérisée en ce qu'**elle comprend un système de déplacement (1) selon l'une quelconque des revendications 1 à 13.

20

25

30

35

40

45

50

55

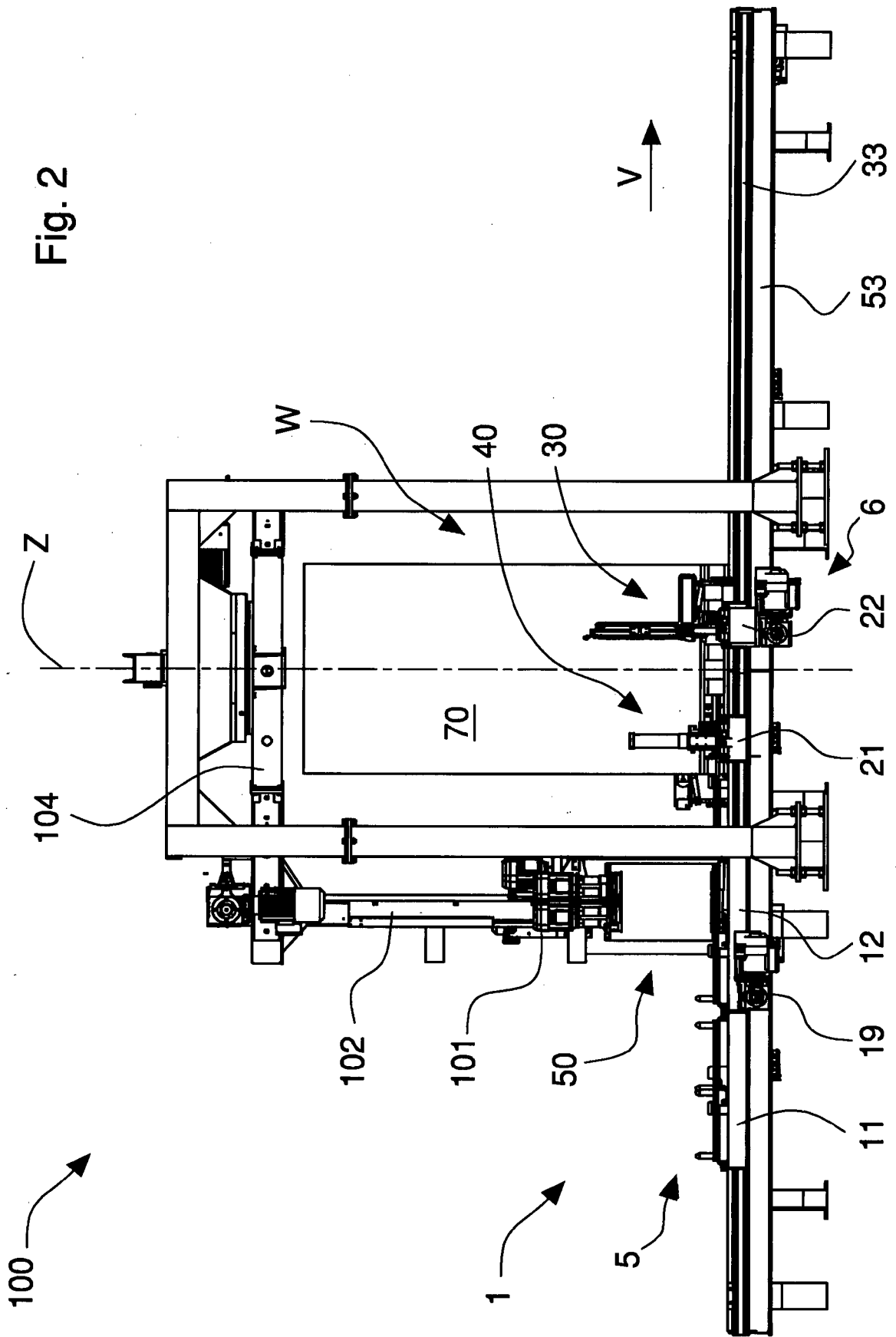

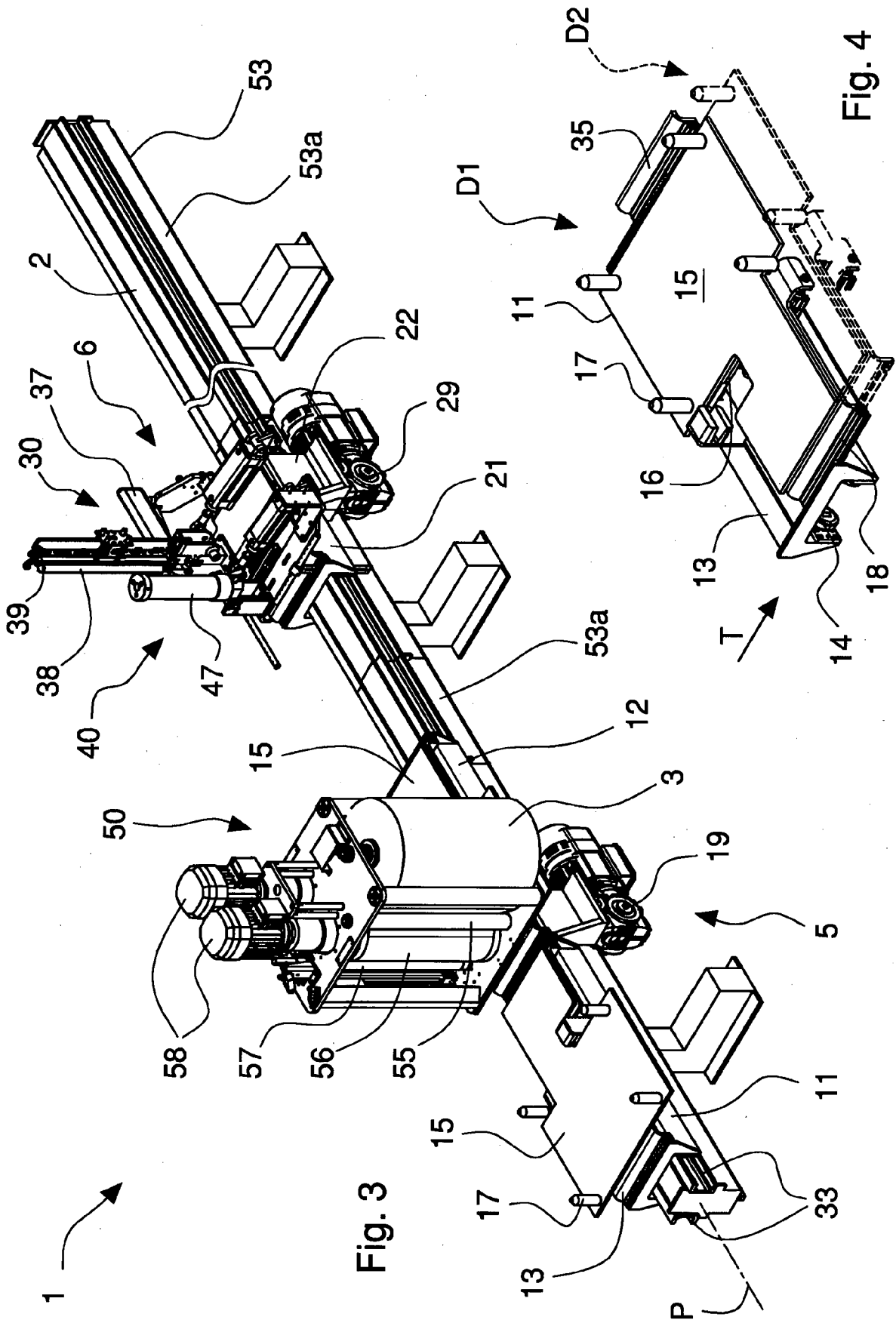

Fig. 3

Fig. 4

Fig. 6

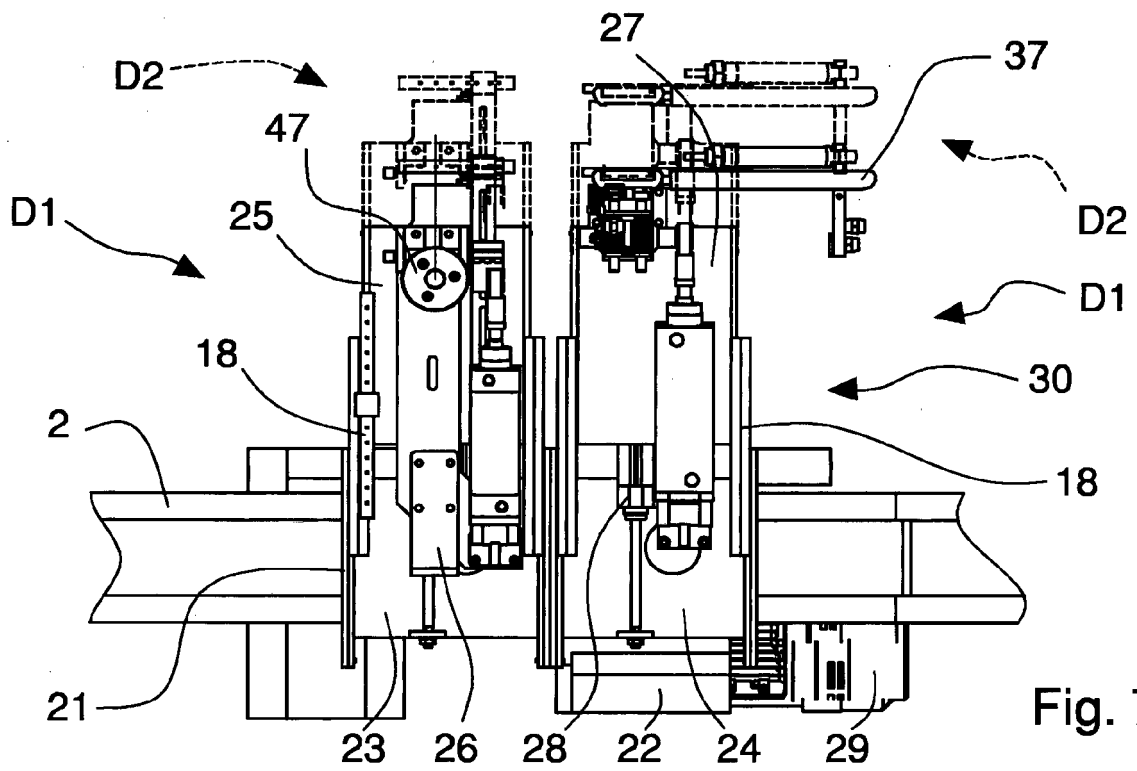
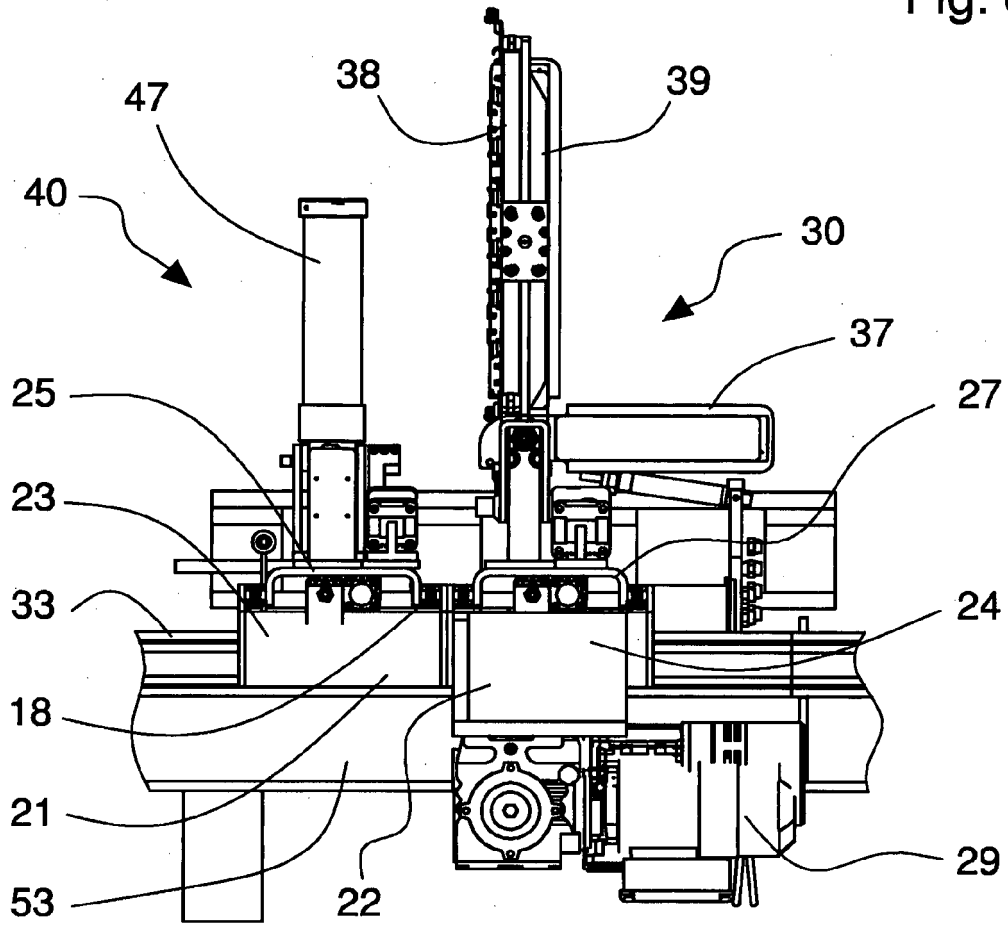

Fig. 7

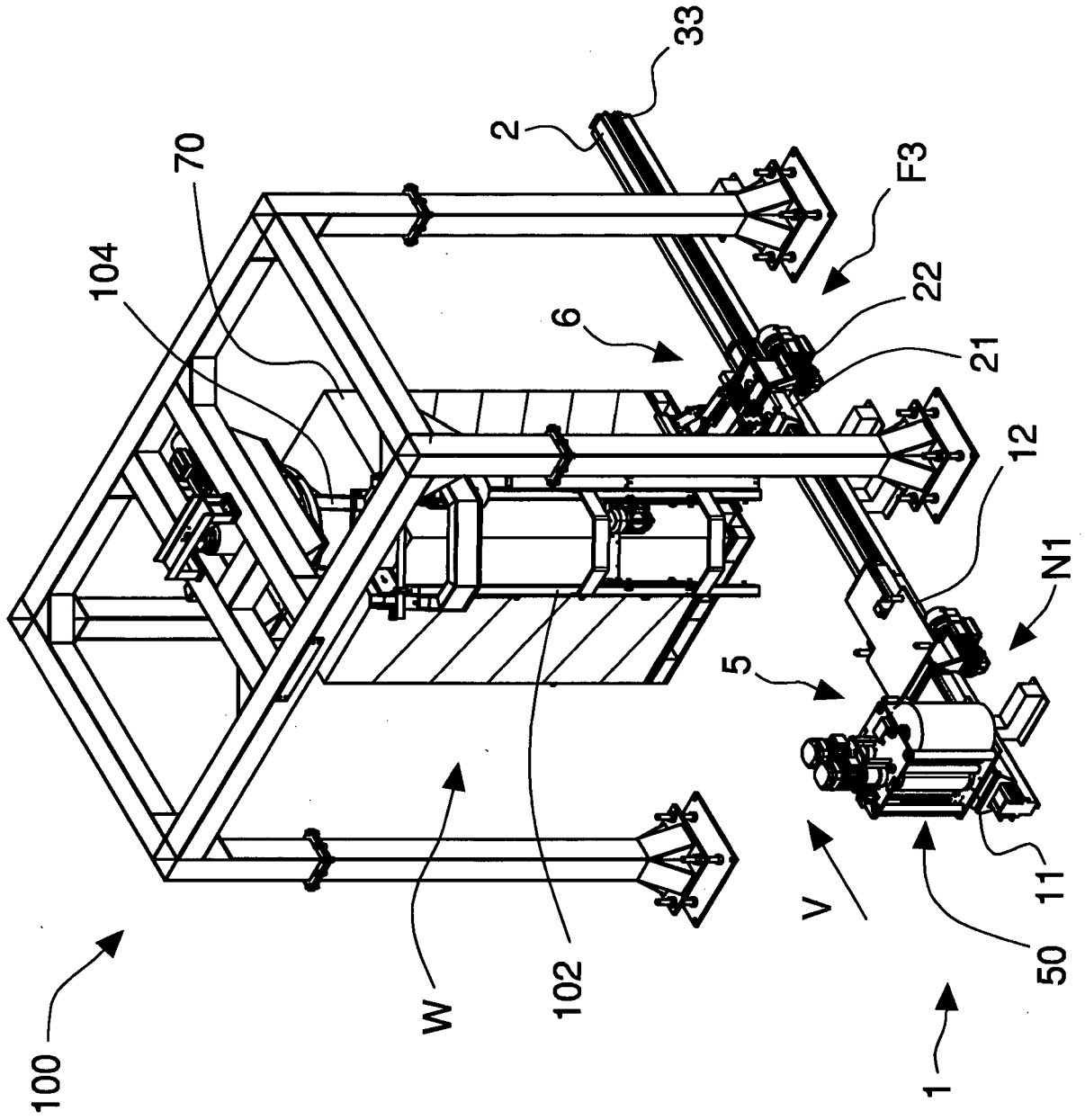

Fig. 10

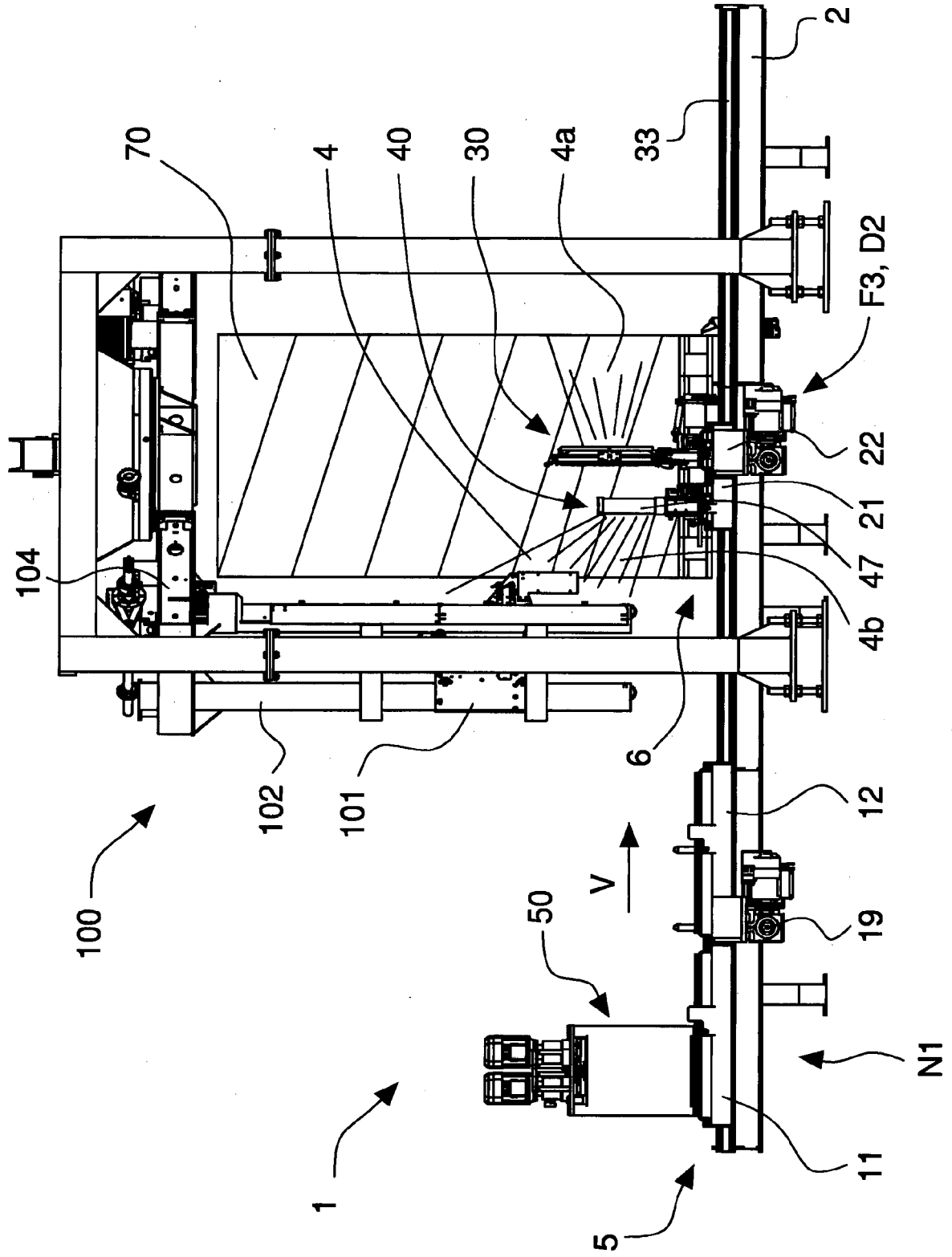

Fig. 11

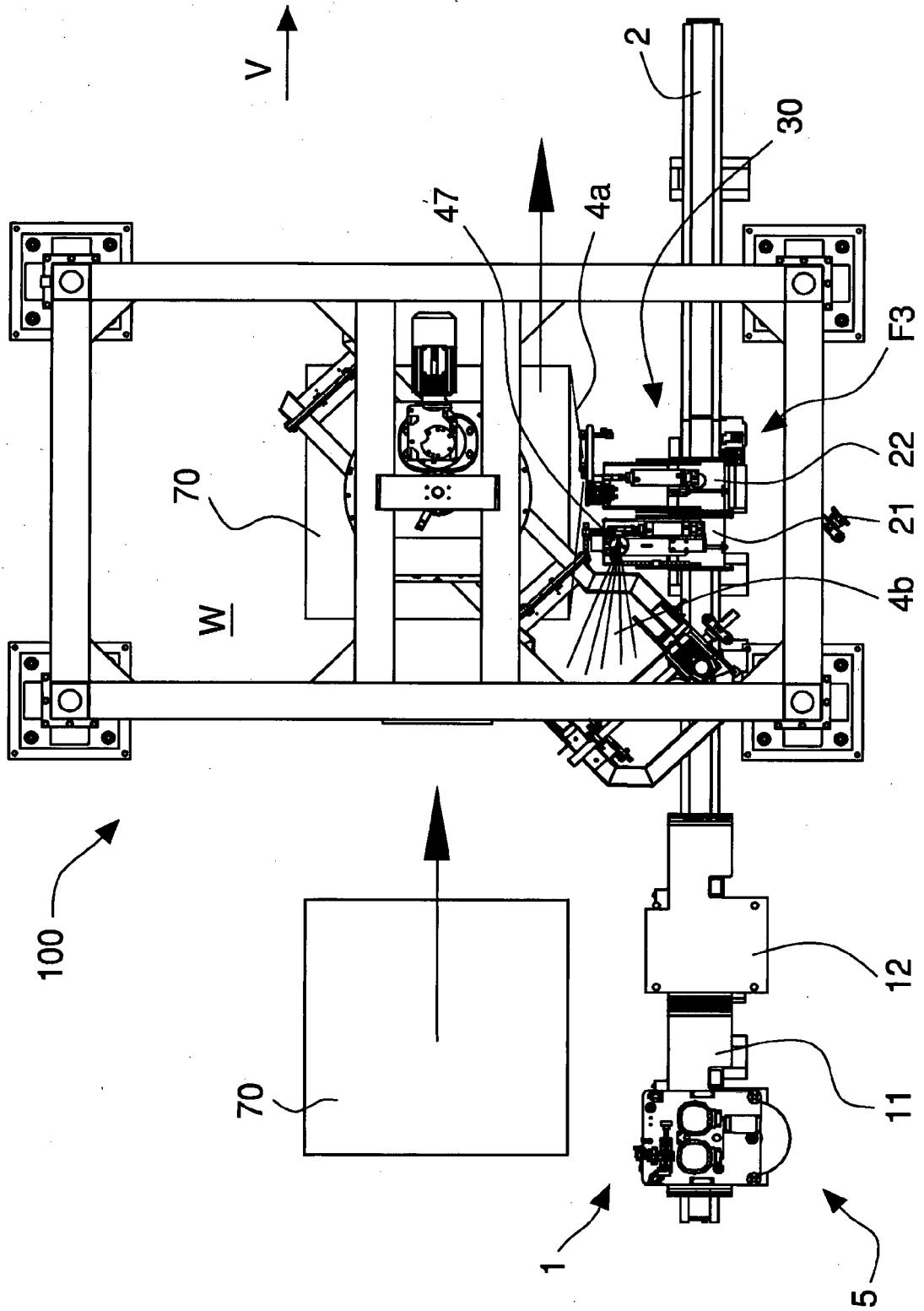

Fig. 12

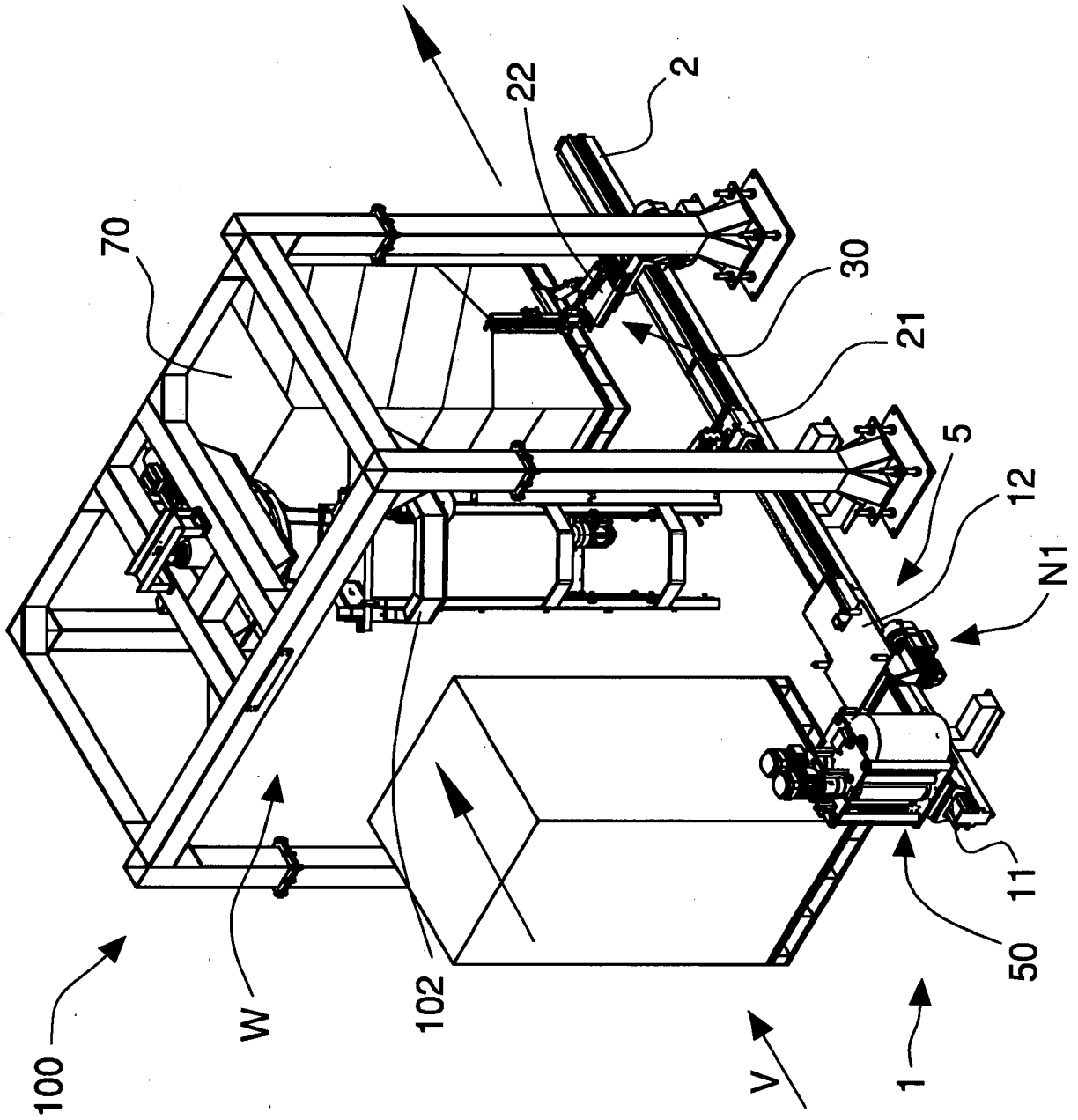

Fig. 13

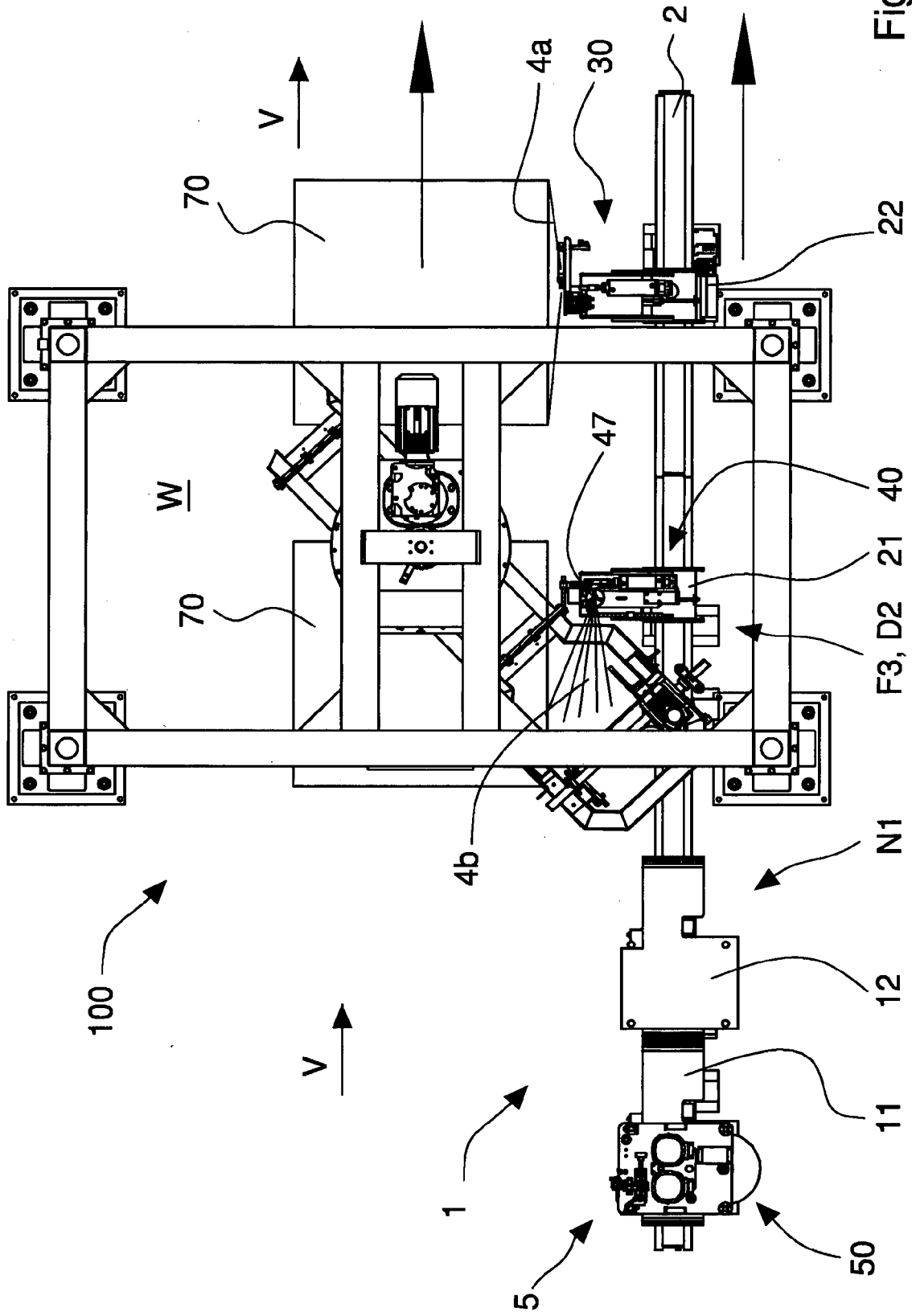
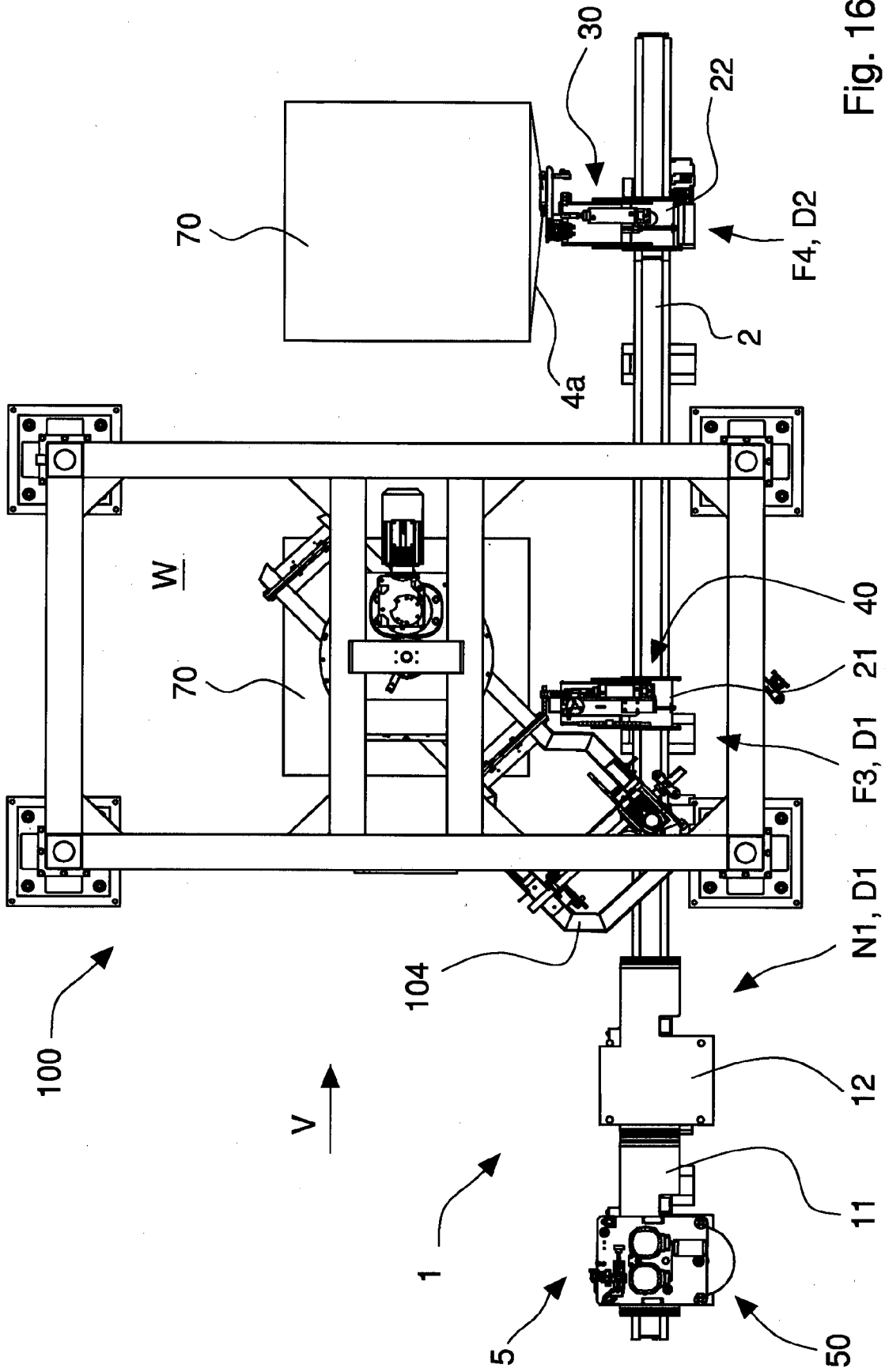

Fig. 14



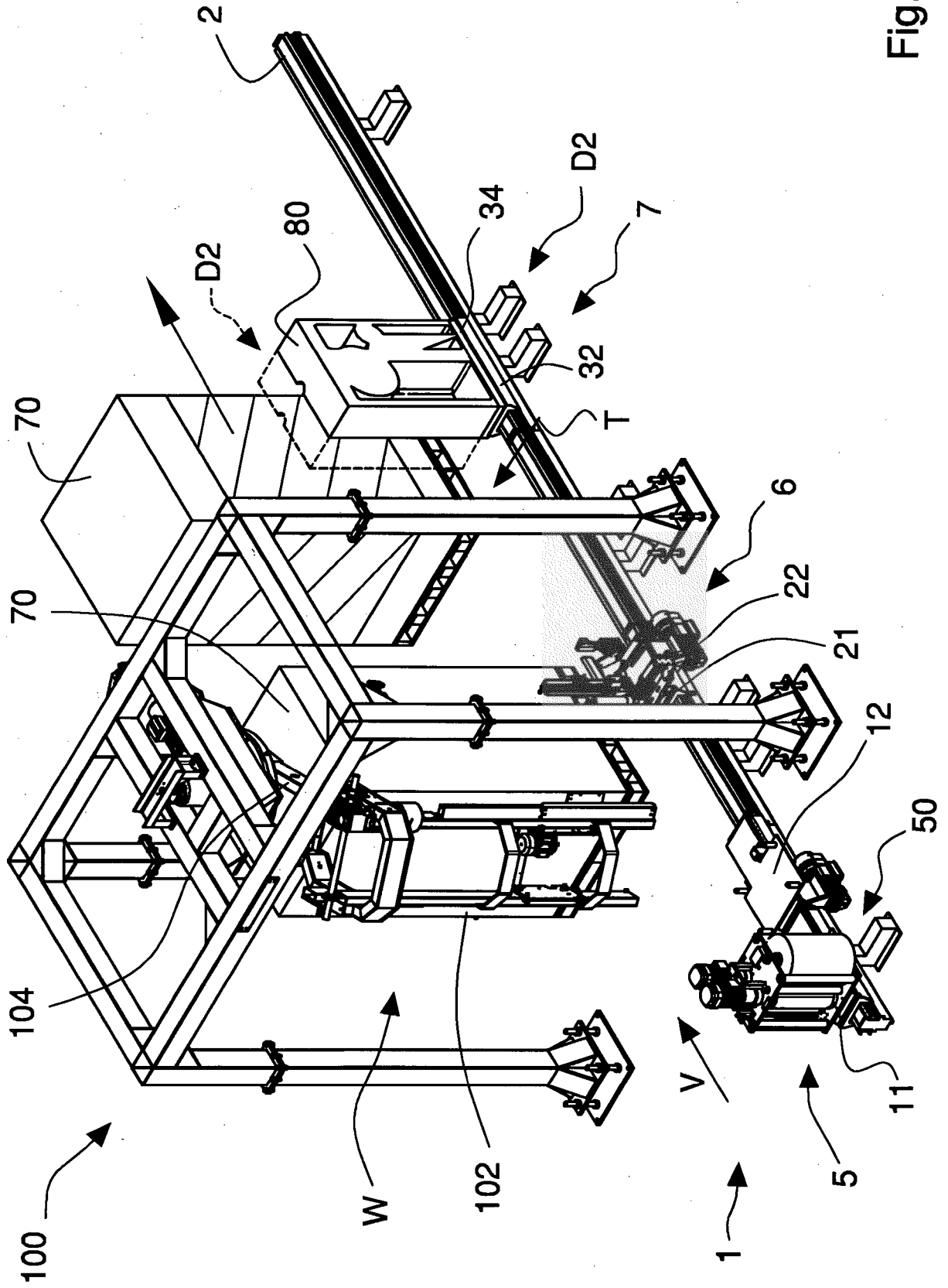

Fig. 17

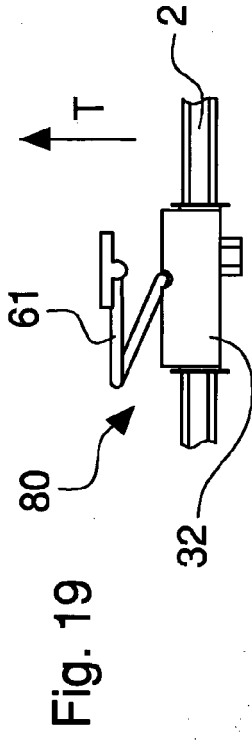

Fig. 19

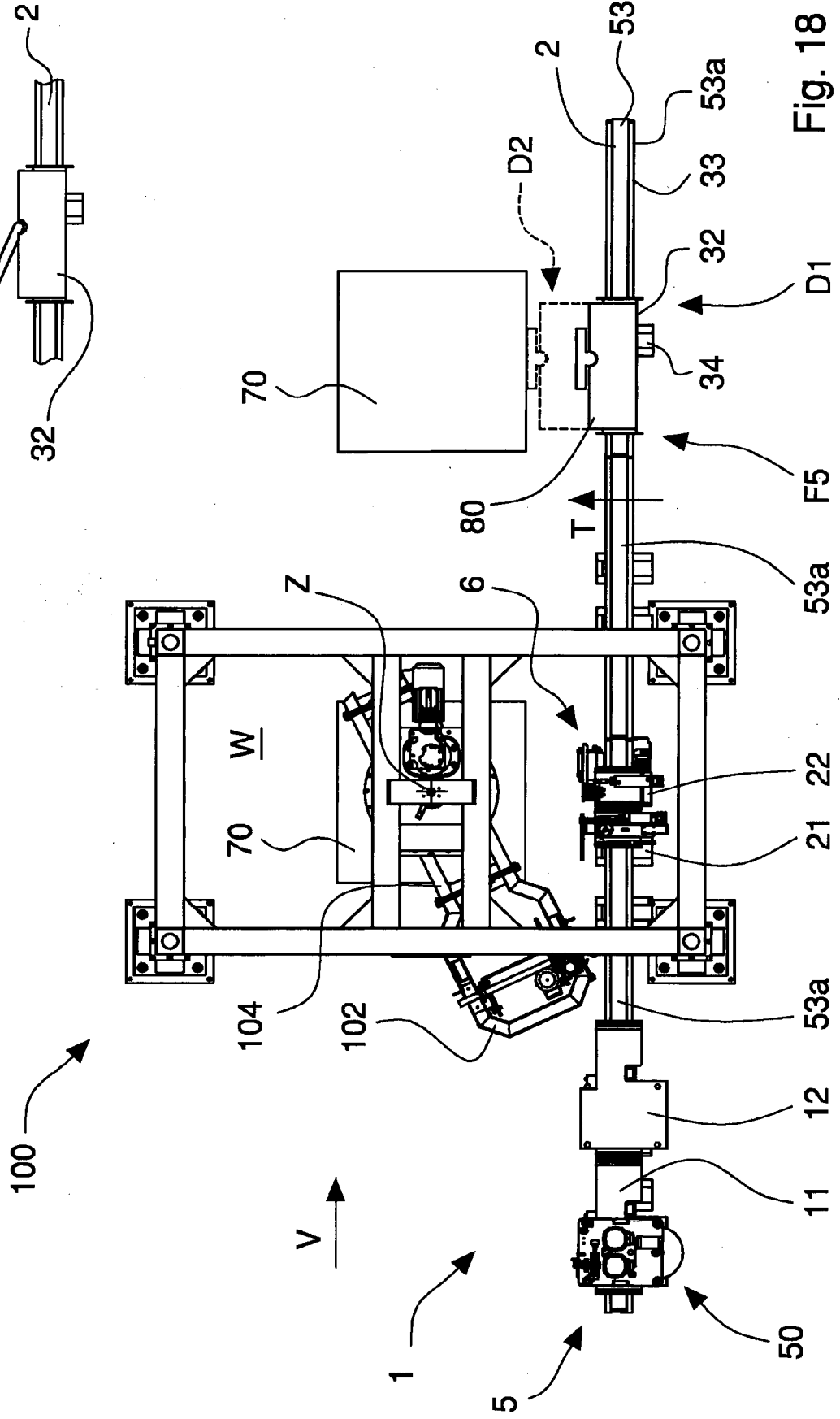

Fig. 18

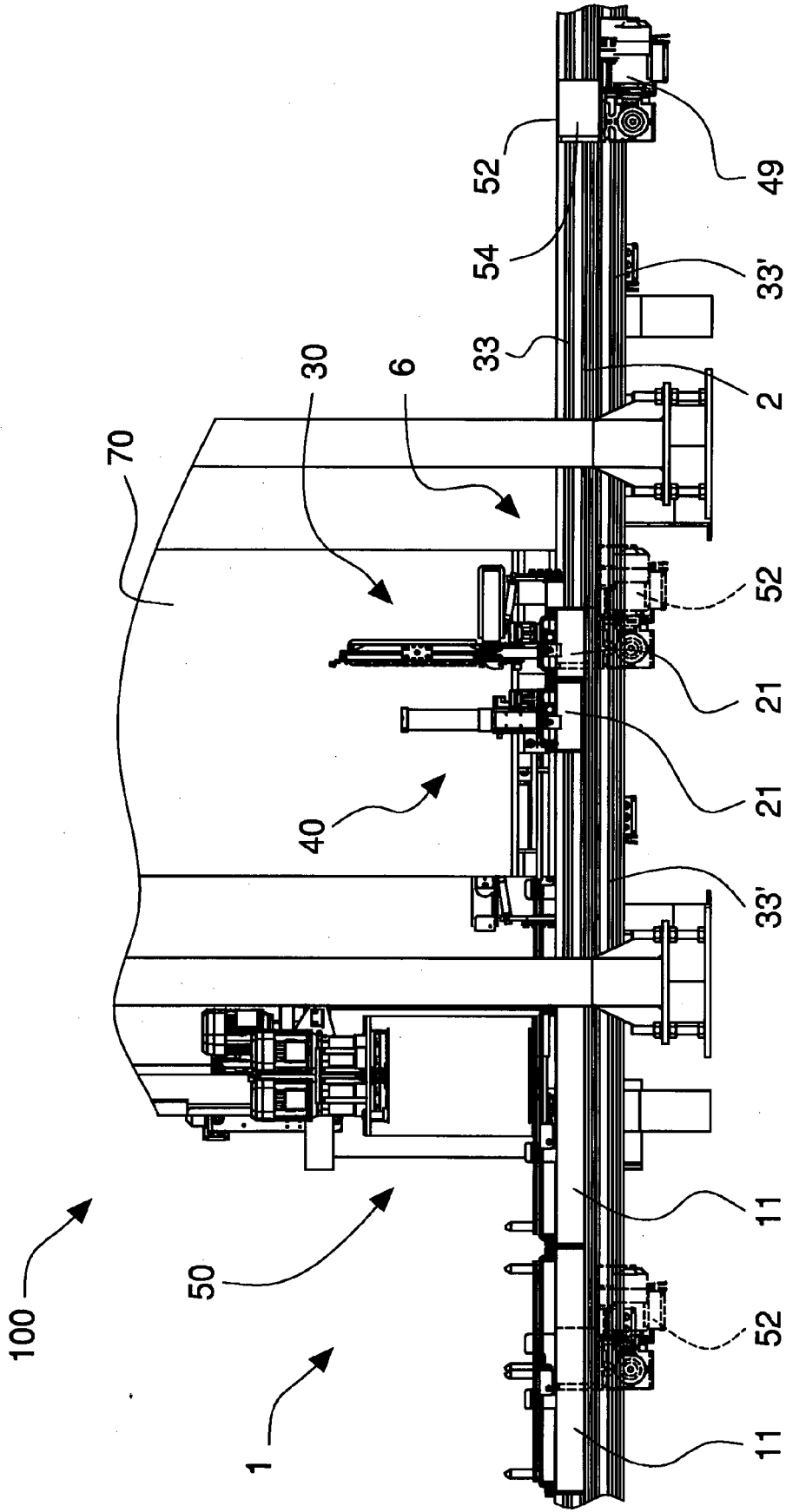

Fig. 22

REFERENCES CITED IN THE DESCRIPTION

This list of references cited by the applicant is for the reader's convenience only. It does not form part of the European patent document. Even though great care has been taken in compiling the references, errors or omissions cannot be excluded and the EPO disclaims all liability in this regard.

Patent documents cited in the description

- US 6553746 B1 [0002]