

(19)



(11)

EP 2 752 518 A1

(12)

EUROPEAN PATENT APPLICATION

(43) Date of publication:
09.07.2014 Bulletin 2014/28

(51) Int Cl.:
D06F 58/20 (2006.01)

(21) Application number: **13150538.0**

(22) Date of filing: **08.01.2013**

(84) Designated Contracting States:
**AL AT BE BG CH CY CZ DE DK EE ES FI FR GB
 GR HR HU IE IS IT LI LT LU LV MC MK MT NL NO
 PL PT RO RS SE SI SK SM TR**
 Designated Extension States:
BA ME

(72) Inventors:
 • **Dal Ben, Diego**
33080 Porcia (PN) (IT)
 • **Pillot, Sergio**
33080 Porcia (PN) (IT)
 • **Santarossa, Marco**
33080 Porcia (PN) (IT)

(71) Applicant: **Electrolux Home Products Corporation
 N.V.**
1130 Brussels (BE)

(74) Representative: **Petrucelli, Davide et al**
Electrolux Italia S.p.A.
Corso Lino Zanussi 30
33080 Porcia (PN) (IT)

(54) **Laundry dryer**

(57) The present invention relates to a household appliance intended for drying clothes comprising a laundry drying chamber rotatably mounted in a cabinet (2), an air inlet path (3) for conveying air inside the appliance (1), and an air outlet path (4) exhausting air from the appliance (1), the inlet path (3) and/or outlet path (4) communicating with the environment outside the appliance (1) through a bottom side (32) of the cabinet (2), the cabinet (2) resting on a support plane (10) by means of a plurality

of supports (17) which form a space between the bottom side (32) of the cabinet (2) and the support plane (10). The laundry dryer of the invention has a sealing which is formed between an air inlet flow (13), and an air outlet flow (14) by means of a gasket (5) placed between the support plane (10) and the lower edge (34) of a partition (6) separating the air inlet path (3) and the air outlet path (4).

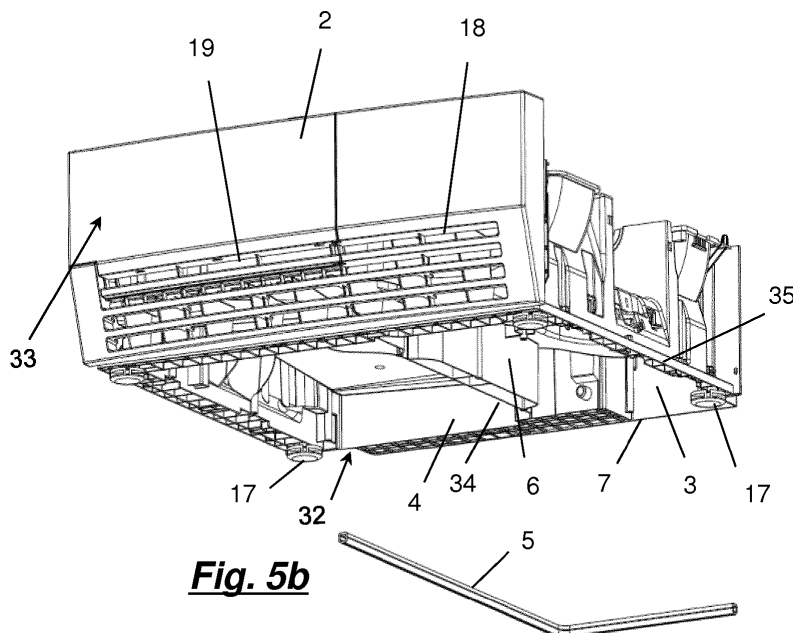

Fig. 5b

EP 2 752 518 A1

Description

Field of technology

[0001] The present invention relates to a household appliance, such as a laundry treating machine. In particular, the present invention relates to a household appliance suitable for drying clothes, i.e. a laundry dryer.

Background

[0002] A tumble dryer is an appliance intended for drying clothes, which has an article drying chamber where the clothes to be dried are introduced.

[0003] The drying chamber is rotatably supported within a cabinet and made to rotate by means of a driving motor, typically consisting of an electric motor connected to the drying chamber via a belt. Operation of the dryer is controlled by the user through a control panel, typically situated on the front or upper panels of the cabinet.

[0004] Generally, laundry drying machines may be divided in two categories according to the air circuit type implemented therein with the purpose of managing a flow of drying air (process air). Laundry machines of a first category are denoted as vented dryers. In operation, vented dryers draw air from the outside into the laundry machine, heat it, then blow the heated air through the laundry to be dried and finally exhaust back outside such air - together with moisture absorbed from the laundry. Laundry drying machines of the second category are denoted as condensation dryers. Condensation dryers are provided with a closed drying air circuit (process air circuit) comprising a moisture condensing unit - or simply, condensing unit - adapted to condense moisture dispersed in process air; therefore, there is no exhaustion of moisturized air from the laundry machines during operation.

[0005] Condensation dryers may be further subdivided in two subtypes, according to the device used for condensing moisture from process air. The condensation dryers of the first subtype are provided with an air-air heat exchanger, which cools and de-moisturizes the process air by taking, and then exhausting, air from/to outside the dryer thereby using such ambient air as a coolant. Conversely, the condensation dryers of the second subtype are provided with a heat pump system, which has a refrigerant fluid evaporator portion for cooling and de-moisturizing the process air.

[0006] In a condensation dryer, a drying air inlet path, e.g. a duct or a passage for drying air, is connected to the drying chamber on one side thereof, and a drying air exhaust path, e.g. another duct, starts from the other side of the drying chamber, while a fan draws air through the inlet path and forces it through the drying chamber, from which the air exits via the exhaust duct.

[0007] In a known condensation dryer provided with an air-air heat exchanger which is shown in Figures 1 and 2, a cooling air flow 13 is typically drawn into the

dryer through a grid 18 e.g. placed at the base of the front panel, and/or from a bottom side of the cabinet, through a grid 16 provided in the bottom closing panel 20, as can be seen in Figure 1.

[0008] Entrance of a cooling air flow 13, from the environment outside the appliance into the cabinet 2 thereof, can be seen in Figure 2, where the bottom closing panel 20 has been removed to better show the internal components of the dryer.

[0009] After having passed an air-air heat exchanger for cooling and de-moisturing the laundry drying air, the cooling air is discharged at a temperature higher than that of the ambient outside the appliance through a further grid 19 at the base of the cabinet 2 front panel, e.g. on the left side, as can be seen in Figure 1.

[0010] Exit of the cooling air from the cabinet 2 of the appliance is shown in Figure 1 and 2 by arrow 14.

[0011] At the lower corners of the appliance cabinet 2, supporting feet 17 are provided, whose height is normally adjustable to ensure accurate positioning and leveling of the cabinet 2, in case the floor on which the machine is installed is slightly uneven or somewhat slanted. For this reason, the bottom closing panel 20 does not rest directly on the floor of the room where the machine is installed, but it is raised from it. Moreover, a free space between the bottom closing panel 20 and the room floor is useful for allowing air to enter the bottom grid 16. Due to the presence of this free space and to the fact that the bottom closing panel 20 does not guarantee a perfect seal, leakages of the air outlet flow 14 can occur along the border of the cover 20, as indicated by the arrows 21 in Figure 1.

[0012] Therefore, mixing of the cooling air outlet flow 14 with cooling air inlet flow 13 is likely to happen.

[0013] The lack of a complete seal between the inlet and outlet flow of air that cools the air-air heat exchanger provided for condensing moisture in the drying air, affects negatively the performance of the dryer. In fact temperature of ambient air taken into the appliance for cooling the air-air heat exchanger is raised by an amount 21 of warmer air discharged from the appliance, and therefore the inlet flow cooling capacity is lowered.

[0014] Moreover, the cover 20 is a further part of the cabinet to be mounted, which requires time.

[0015] Patent application EP1092802 describes a washing and/or drying machine comprising a cabinet and electric components located within the cabinet. The cabinet has feet for standing on a plane thus determining the presence of a space between the lower end of the cabinet and the plane. To avoid water reaching the electric components within the cabinet, a protection element is associated to the lower edge all around the cabinet. Such protection element is however provided with passages for air circulation.

[0016] Japanese publication JP 5184515 describes a washing/drying machine in which a foamed packing is provided within a groove extending over almost the whole periphery of the bottom face plate. The task of the packing is to close the clearance between the bottom face and

the floor surface, so as to interrupt the leaking of noise from the bottom face of the frame. The packing is provided with an opening allowing air and water to pass through it.

[0017] Known systems are not suitable to provide efficient and easy to be mounted separation between incoming (cool) air flows and outgoing (hot) air flows, thus reducing the appliances performances.

Objects of the disclosure

[0018] It is an object of the present disclosure to overcome at least some of the problems associated with the prior art.

[0019] A further object of the present invention is to provide a laundry drying appliance, in which the air flow coming out from appliance is kept separated from the air flow entering the appliance.

[0020] Another object of the invention is to provide a laundry drying appliance in which, due to the fact that the air flow coming out from the appliance is not mixed with the air entering the appliance, an improved performance of the appliance can be obtained.

[0021] Still a further object of the invention is to achieve the objects mentioned above by means of a simple and cost-effective solution, which does not require changes to the structure of the appliance.

[0022] Another object of the invention is to provide a solution for separating an air flow entering an appliance having laundry drying function from a flow of air exhausted from the same appliance, such solution being applicable to any type of laundry dryer, i.e. a vented type laundry dryer, a condenser-type laundry dryer comprising a moisture condensing unit including an air-air heat exchanger or a heat-pump system.

Summary of the invention

[0023] According to the invention, the present disclosure provides a laundry dryer comprising a laundry drying chamber rotatably mounted in a cabinet, an air inlet path for conveying air inside the appliance, and an air outlet path exhausting air from the appliance, the inlet path and/or outlet path communicating with the environment outside the appliance through a bottom side of the cabinet, the cabinet resting on a support plane by means of a plurality of supports which form a space between the bottom side of the cabinet and the support plane, the laundry dryer has a sealing which is formed between an air inlet flow, and an air outlet flow by means of a gasket placed between the support plane and the lower edge of a partition separating the air inlet path and the air outlet path.

[0024] In one embodiment of the invention the gasket extends along a portion of the cabinet outer lower edge.

[0025] In an aspect of the invention, the partition extends from a front panel of the cabinet and a rear region of said cabinet.

[0026] In a further aspect of the invention, the gasket extends along a portion of the cabinet outer lower edge which is substantially perpendicular to the lower edge of the partition.

5 **[0027]** In another aspect of the invention the gasket extends along a portion of the cabinet outer lower edge which is substantially parallel to the lower edge of the partition.

[0028] In one embodiment of the invention the gasket is flexible so as to compensate for variation in the clearance between the lower edge of the partition and/or the cabinet and the support plane.

[0029] According to one aspect of the invention, the gasket is hollow.

15 **[0030]** In a further aspect of the invention, the gasket is square or rectangular in section. According to an embodiment of the invention, the air inlet path conveys ambient air towards the laundry drying chamber and the air outlet path exhausts air from the laundry drying chamber toward the environment outside the appliance.

[0031] In another embodiment of the invention, the laundry dryer comprises a drying air circuit recirculating drying air cyclically through the laundry drying chamber, a moisture condensing unit being provided in said drying air circuit for condensing moisture removed from laundry to be dried, wherein the air inlet path is connected to an inlet side of the moisture condensing unit and the air outlet path is connected to the outlet side of the moisture condensing unit.

20 **[0032]** In a further embodiment of the invention, the laundry dryer comprises a heat pump system which includes a compressor and heat exchangers for supplying heated dried air to the laundry drying chamber and for de-moisturizing drying air exiting said chamber, in which the air inlet path and the air outlet path respectively convey air towards/from said compressor.

25 **[0033]** The present invention offers a number of benefits. One of the advantages of the invention is that a complete sealing between a flow of air entering the appliance and a flow of air exhausted from the appliance is guaranteed by the presence of a gasket, which separates the air inlet path from the air outlet path. In other words, a complete separation between the two air paths is obtained.

30 **[0034]** This also prevents mixing of the inlet air flow and the outlet air flow.

[0035] Another advantage is that the cover at the bottom of the cabinet can be omitted. Yet a further advantage of the invention is that the section of the inlet air flow and air outlet flow can be enlarged.

35 **[0036]** Another advantage of the invention is that, as a result of the advantages mentioned above, the overall performance of the laundry dryer is improved.

55 Brief description of the drawings

[0037] Reference will now be made, by way of example, to the accompanying drawings, in which:

Figure 1 is a schematic bottom view of a prior art tumble dryer with a bottom cover plate;

Figure 2 is a bottom perspective view of the tumble dryer shown in Figure 1 where the bottom cover plate has been removed;

Figures 3a and 3b show a tumble dryer according to the invention in a front view and an enlarged perspective view respectively;

Figure 4a shows a bottom view of the tumble dryer of Figures 3a, 3b;

Figure 4b is a partial front sectional view of the bottom region of the tumble dryer of Figures 3a, 3b;

Figure 5a and 5b are bottom perspective views of the tumble dryer of Figures 3a, 3b.

Detailed description of preferred embodiment

[0038] While the invention has been described in connection with preferred embodiments, it is not intended to limit the scope of the invention to the particular form set forth, but on the contrary, it is intended to cover such alternatives, modifications, and equivalents as may be included within the scope of the invention as defined by the appended claims. Even if the invention will be described here below with reference to a condenser-type laundry dryer, the invention may be applied also in a vented-type laundry dryer.

[0039] Referring to Figures 3a and 3b, the household appliance being described is a tumble dryer 1 that has article laundry drying chamber where the clothes to be dried are introduced. The drying chamber is closed by a door 30 and it has not been shown in detail in the drawings.

[0040] The drying chamber is rotatably supported within a cabinet 2 and made to rotate by means of a driving means, typically consisting of an electric motor connected to the drying chamber via a belt. Also the driving means, as well as other operational means and components which are located within the cabinet 2 and are needed for carrying out a drying process on laundry, have not been shown in detail in the drawings.

[0041] The cabinet 2 rests on a support plane 10, typically the floor of a room where the appliance is installed. At the lower corners of the cabinet 2, supporting feet 17 are present, whose height is adjustable to ensure accurate positioning and leveling of the cabinet.

[0042] Operation of the dryer is controlled by the user by means of a control panel 11, situated on the front or upper panel of the cabinet 2.

[0043] The clothes to be dried are introduced into the drying chamber through an aperture 12 formed in the cabinet 2 and closed by the door 30. In the exemplary embodiment shown in the drawings, clothes are dried by a drying air flow that is recirculated cyclically through the drum. Drying air flow is de-moisturized before entering the drum by a moisture condensing unit that is cooled by a cooling air flow taken from the ambient outside the appliance 1. Such cooling air is exhausted from the appli-

ance 1 after having cooled the moisture condensing unit.

[0044] An air inlet path 3 is connected to an inlet side of the moisture condensing unit and an air outlet path 4 is connected to the outlet side of the moisture condensing unit. The air inlet path 3, the air outlet path 4 and the moisture condensing unit define a cooling air circuit. The moisture condensing unit is further in fluid communication with a drying air circuit where drying air circulates. A fan is provided both in the cooling air circuit both in the drying air circuit

[0045] A air inlet flow 13, passing through a gap left between the lower outer edge 7 of the appliance 1 and the floor 10, due to the presence of the feet 17, is drawn into the cabinet 2 from the environment outside the appliance 1 through a bottom side 32 of the cabinet 2. The air inlet flow 13 is further drawn into the cabinet 2 through a front inlet grid 18, made in the front panel 33 of the cabinet 2, e.g. at a bottom region of the front panel 33 close to the right side of the appliance 1.

[0046] A air outlet flow 14 exits the appliance 1 through a front outlet grid 19, made in the front panel 33 of the cabinet 2, e.g. at a bottom region of the front panel 33 close to the left side of the appliance 1. The air outlet flow 14 further exits the appliance 1 through the gap left between the lower outer edge 7 of the appliance 1 and the floor 10.

[0047] The air inlet flow 13 is guided into the appliance 1 by means of the air inlet path 3, and the air outlet flow 14 is guided outside the appliance 1 through the air outlet path 4.

[0048] In the bottom side 32 of the cabinet 2, as shown in Figures 4a to 5b, a partition 6 separates the air inlet path 3 and the air outlet path 4, along which the air inlet flow 13, and the air outlet flow 14 run. The partition 6 extends from the front panel 33 of the cabinet 2 to a rear side thereof.

[0049] According to the invention, a sealing is formed between the air inlet flow 13, and the air outlet flow 14 by means of a gasket 5 placed between the lower edge 34 of the partition 6 separating the air inlet path 3 and the air outlet path 4 and the support plane 10. In this way any mixing of the air inlet flow 13 with air outlet flow 14 is avoided.

[0050] In order to avoid that part of the air inlet flow 13 exits the appliance 1 instead of being directed towards the moisture condensing unit, the gasket 5 extends along a rear portion of the cabinet 2 outer lower edge 7. The outer lower edge 7 of the rear portion of the cabinet 2 extends substantially perpendicularly to the lower edge 34 of the partition 6. This can be easily seen in Figures 4a, 5a and 5b.

[0051] In Figure 5b the gasket 5 is shown detached from the partition 6 and lower edge 7 of the cabinet 2, to better illustrate the shape and extension of the gasket.

[0052] Accordingly, the gasket 5 extends along an "L"-shaped path as shown in Figure 5b. If desired, the gasket 5 may extend along a "U"-shaped path, i.e. along the lower edge 34 of the partition 6 separating the air inlet

path 3 and the air outlet path 4, the a rear portion of the cabinet 2 outer lower edge 7 and a side lower edge 35 extending from the rear to the front part of the appliance 1, i.e. substantially parallel to the lower edge 34 of the partition 6. In this way the air inlet flow is taken into the appliance 1 just from the front side thereof.

[0053] In a first aspect of the invention, the gasket 5 is flexible, so as to compensate for variation in the clearance between the lower edge 7, 34 of the partition 6 and/or the cabinet 2 and the support plane 10. These variations can occur due to the floor on which the machine is installed being slightly uneven or somewhat slanted of whether feet 17 are adjusted.

[0054] To better improve flexibility and sealing capacity, the gasket 5 has a hollow body. In a second aspect of the invention, the gasket 5 is square or rectangular in section.

[0055] Once the gasket 5 has been applied to the partition 6 and lower edge 7 of the cabinet 2, it closes the gap left between them and the floor 10, thus preventing the air inlet flow 13 and the air outlet flow 14 from being mixed up.

[0056] Moreover, the section of the inlet air flow 13 can be enlarged compared to the prior art laundry dryer having a bottom closing panel 20.

[0057] Also, the bottom closing panel 20 at the bottom of the cabinet is no longer necessary.

[0058] As a result of the advantages mentioned above, the overall performance of the tumble dryer is improved.

[0059] It will be understood that, while in the foregoing reference was mainly made to a household appliance embodied in the form of a condenser-type tumble dryer, the present invention is suitable any other apparatus intended for drying clothes. For example the invention described above may be applied to a vented-type laundry dryer wherein the air inlet path 3 conveys ambient air towards the drum and the air outlet path 4 exhausts air from the drum toward the environment outside the appliance 1. The invention may be further applied to a condenser-type tumble dryer having a heat pump system including a refrigerant fluid compressor and heat exchangers for supplying heated dried air to the laundry drying chamber and for de-moisturizing drying air exiting the drum, in which the air inlet path 3, an air outlet path 4 respectively conveys air towards/from an operating component of the laundry dryer provided for carrying out a drying process on laundry, such as the compressor of the heat pump system.

[0060] According to the invention, the air inlet path 3 for conveying air inside the appliance 1, and/or the air outlet path 4 exhausting air from the appliance 1 may communicate with the environment outside the appliance 1 through a bottom side 32 of the cabinet 2.

[0061] It will be appreciated that alterations and modifications may be made to the above without departing from the scope of the disclosure. Naturally, in order to satisfy local and specific requirements, a person skilled in the art may apply to the solution described above many

modifications and alterations. Particularly, although the present disclosure has been described with a certain degree of particularity with reference to preferred embodiment(s) thereof, it should be understood that various omissions, substitutions and changes in the form and details as well as other embodiments are possible; moreover, it is expressly intended that specific elements described in connection with any disclosed embodiment of the disclosure may be incorporated in any other embodiment as a general matter of design choice.

Claims

1. A laundry dryer (1) comprising a laundry drying chamber rotatably mounted in a cabinet (2), an air inlet path (3) for conveying air inside the appliance (1), and an air outlet path (4) exhausting air from the appliance (1), the inlet path (3) and/or outlet path (4) communicating with the environment outside the appliance (1) through a bottom side (32) of the cabinet (2), the cabinet (2) resting on a support plane (10) by means of a plurality of supports (17) which form a space between the bottom side (32) of the cabinet (2) and the support plane (10), **characterised in that** a sealing is formed between an air inlet flow (13), and an air outlet flow (14) by means of a gasket (5) placed between the support plane (10) and the lower edge (34) of a partition (6) separating the air inlet path (3) and the air outlet path (4).
2. A laundry dryer as in claim 1, wherein the gasket (5) extends along a portion of the cabinet outer lower edge (7, 35).
3. A laundry dryer as in claim 1 or 2, wherein the partition (6) extends from a front panel (33) of the cabinet (2) and a rear region of said cabinet (2).
4. A laundry dryer as in claim 2 or 3 wherein the gasket (5) extends along a portion of the cabinet outer lower edge (7, 35) which is substantially perpendicular to the lower edge (34) of the partition (6).
5. A laundry dryer as in any claim 2 to 4 wherein the gasket (5) extends along a portion of the cabinet outer lower edge (7, 35) which is substantially parallel to the lower edge (34) of the partition (6).
6. A laundry dryer as in any preceding claim, wherein the gasket (5) is flexible so as to compensate for variation in the clearance between the lower edge (7, 34) of the partition (6) and/or the cabinet (2) and the support plane (10).
7. A laundry dryer as in any preceding claim, wherein said gasket (5) is hollow.

8. A laundry dryer as in any preceding claim, wherein said gasket (5) is square or rectangular in section.
9. A laundry dryer as in any preceding claim, wherein the air inlet path (3) conveys ambient air towards the laundry drying chamber and the air outlet path (4) exhausts air from the laundry drying chamber toward the environment outside the appliance (1). 5
10. A laundry dryer as in any claim 1 to 8, comprising a drying air circuit recirculating drying air cyclically through the laundry drying chamber, a moisture condensing unit being provided in said drying air circuit for condensing moisture removed from laundry to be dried, wherein the air inlet path (3) is connected to an inlet side of the moisture condensing unit and the air outlet path (4) is connected to the outlet side of the moisture condensing unit. 10 15
11. A laundry dryer as in any claim 1 to 8, comprising a heat pump system which includes a compressor and heat exchangers for supplying heated dried air to the laundry drying chamber and for de-moisturizing drying air exiting said chamber, in which the air inlet path (3) and the air outlet path (4) respectively convey air towards/from said compressor. 20 25

30

35

40

45

50

55

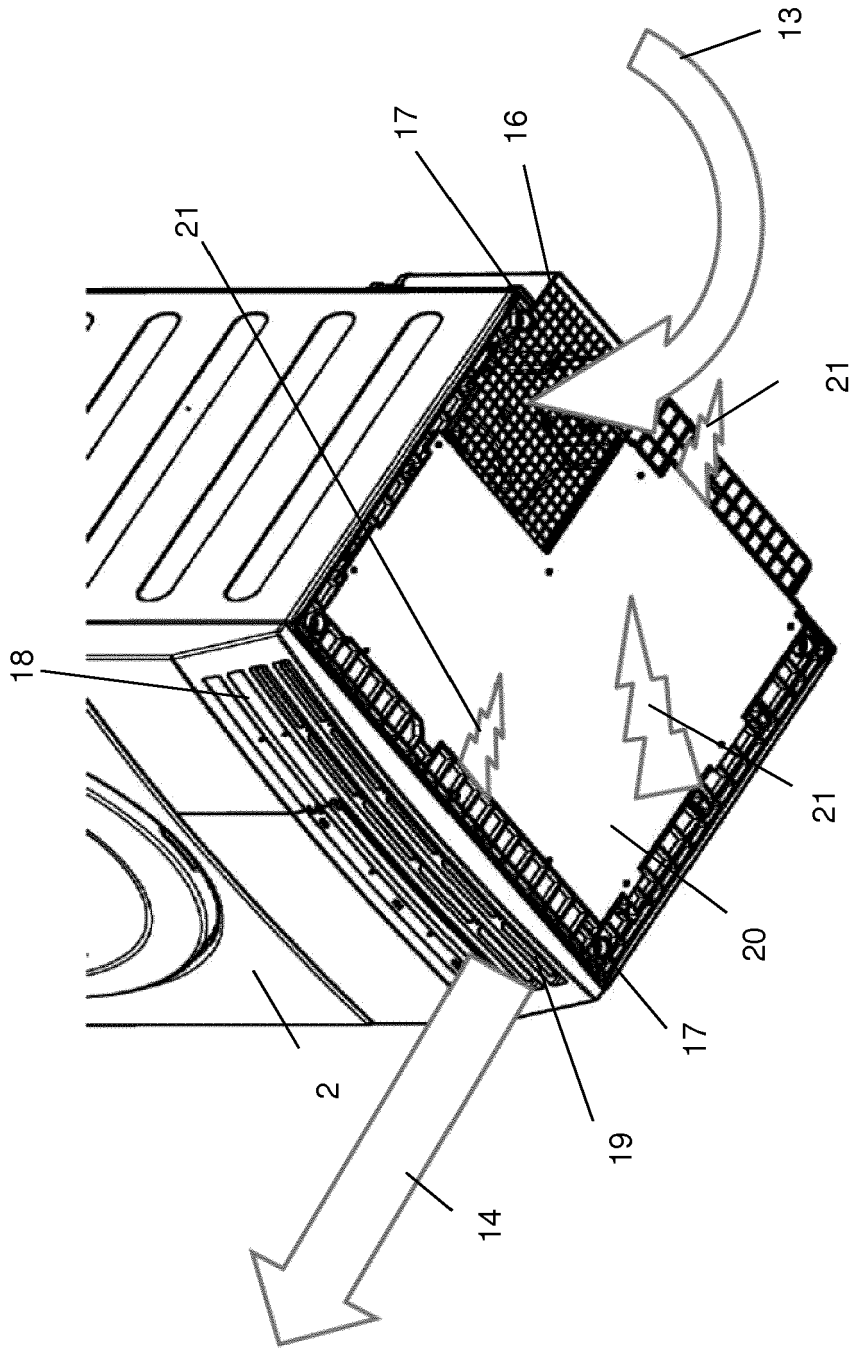

Fig. 1

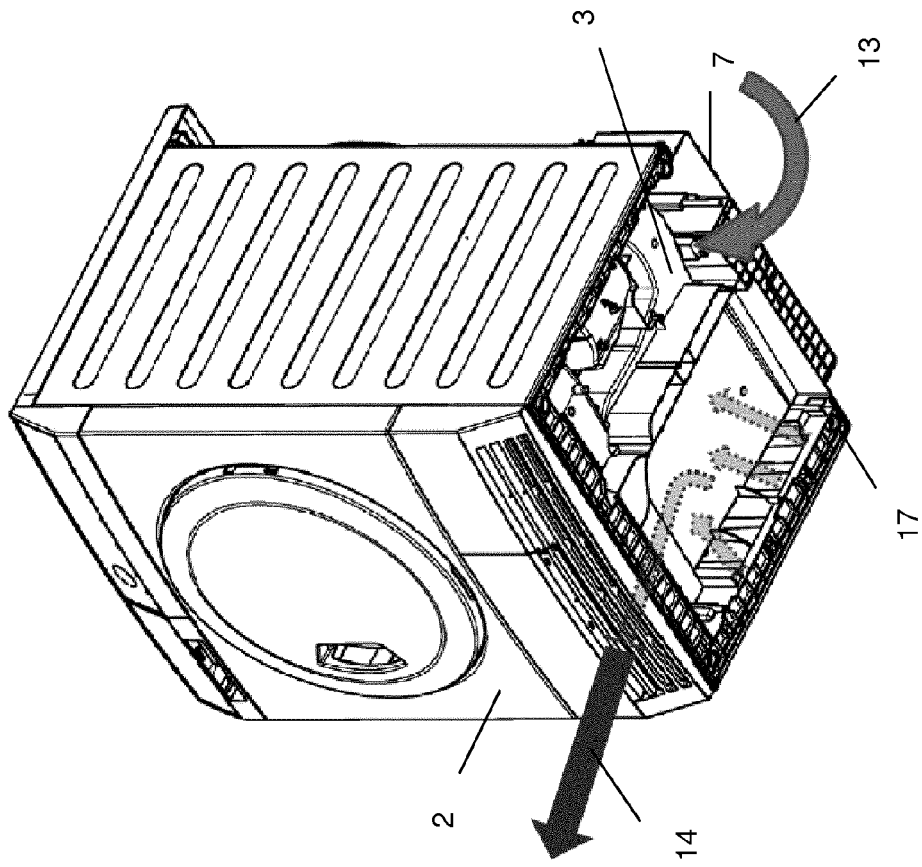
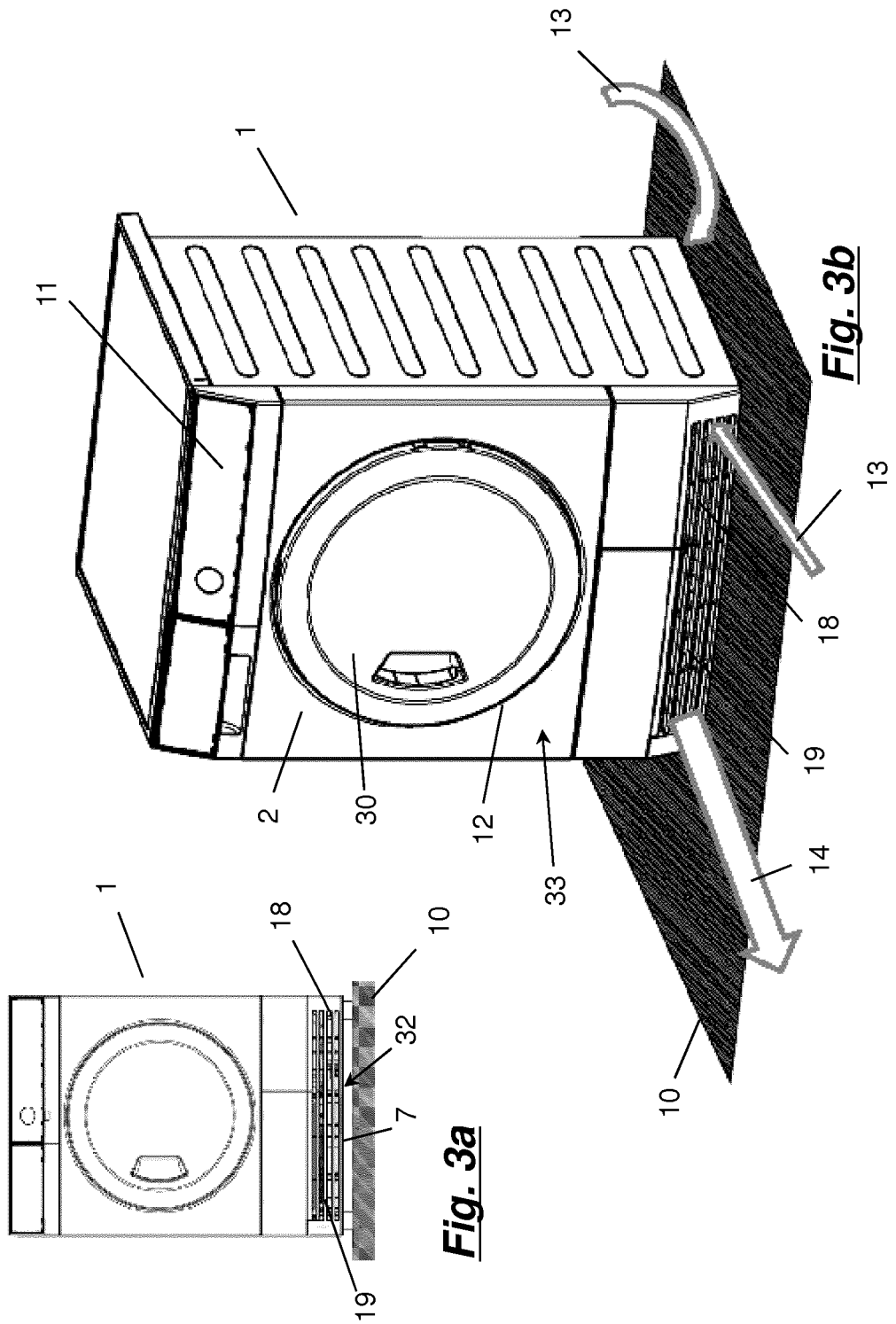
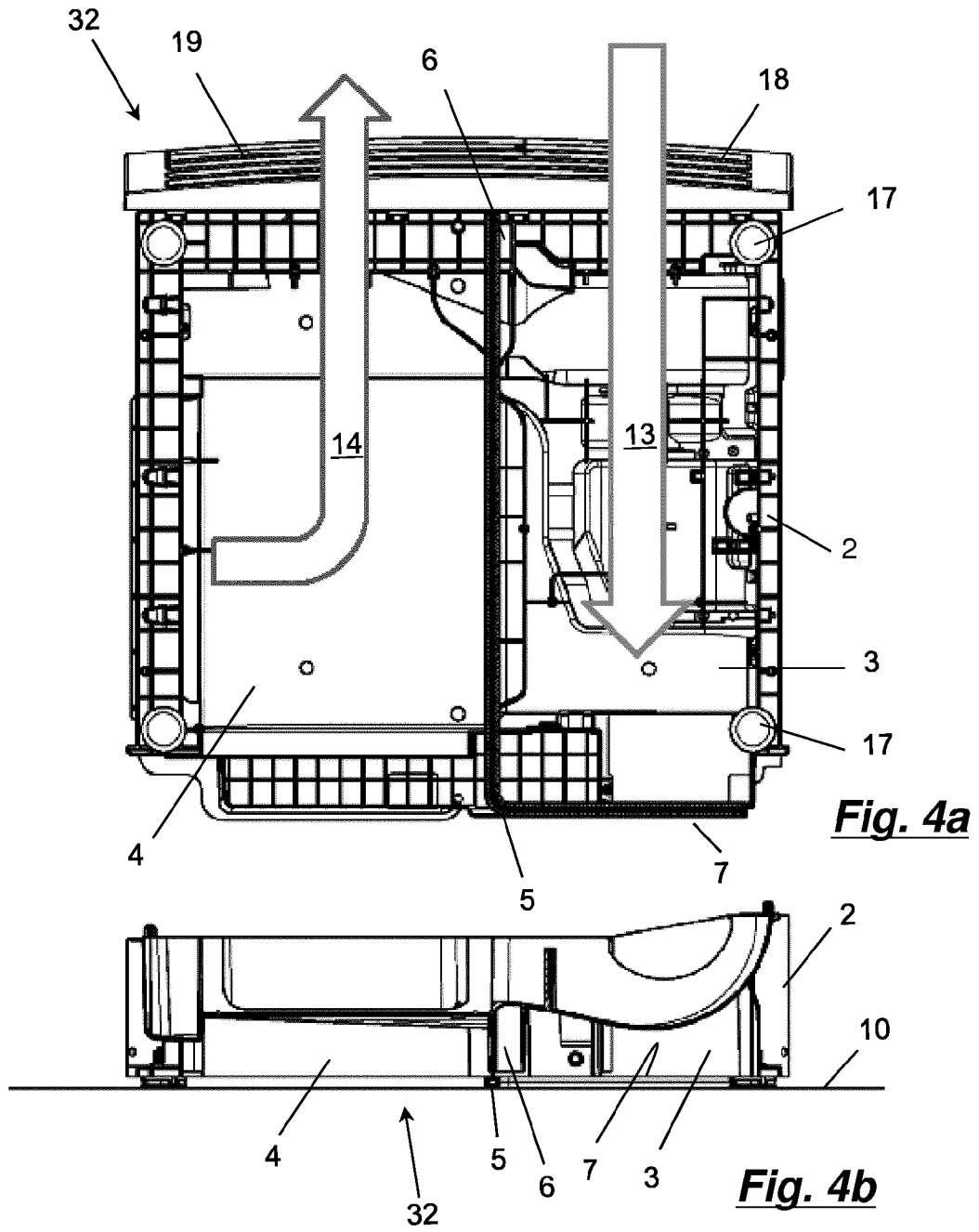

Fig. 2





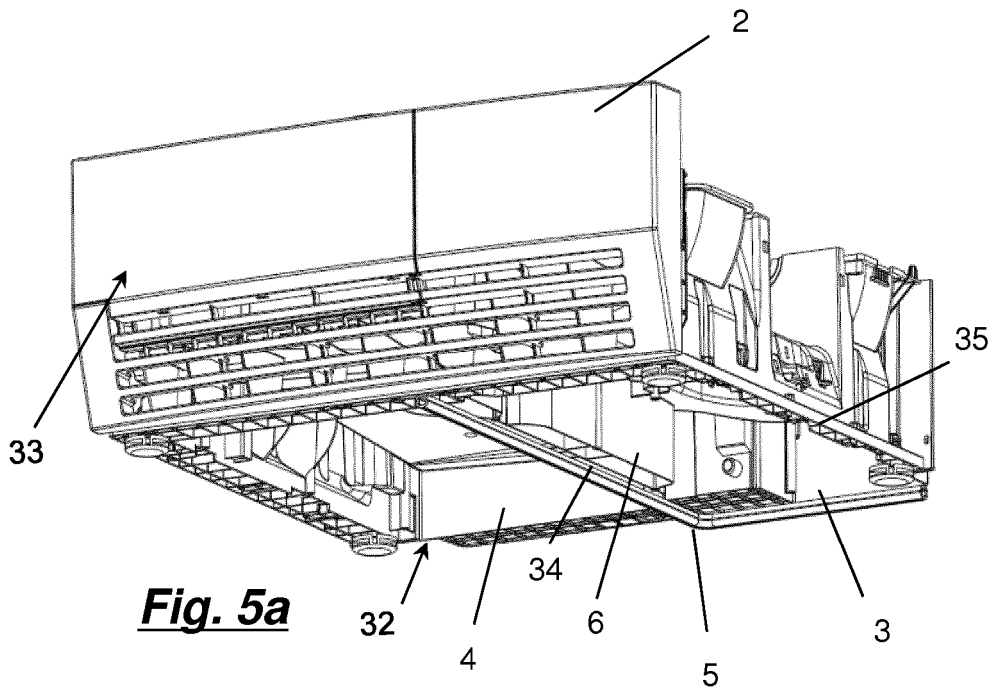

Fig. 5a

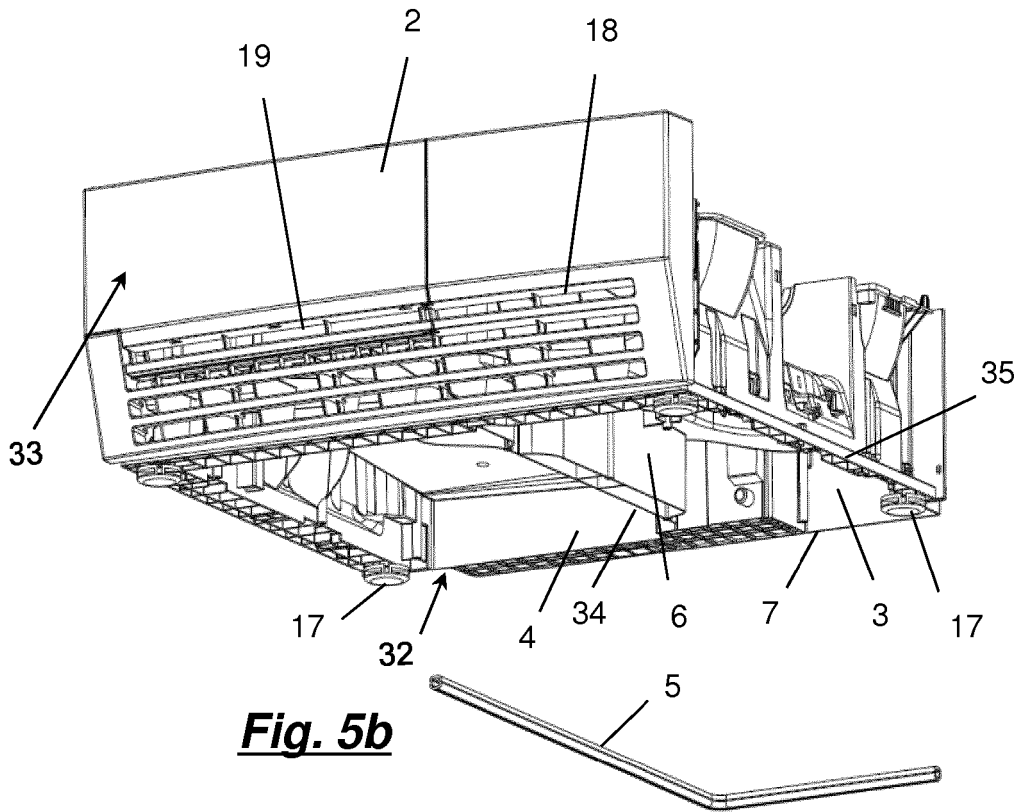

Fig. 5b



EUROPEAN SEARCH REPORT

Application Number
EP 13 15 0538

5

10

15

20

25

30

35

40

45

50

55

DOCUMENTS CONSIDERED TO BE RELEVANT			
Category	Citation of document with indication, where appropriate, of relevant passages	Relevant to claim	CLASSIFICATION OF THE APPLICATION (IPC)
A	EP 2 423 376 A1 (ELECTROLUX HOME PROD CORP [BE]) 29 February 2012 (2012-02-29) * paragraphs [0037] - [0041]; figures 1-5 *	1,10,11	INV. D06F58/20
A	DE 10 2005 013051 A1 (BSH BOSCH SIEMENS HAUSGERAETE [DE]) 21 September 2006 (2006-09-21) * paragraphs [0010], [0016]; figure 1 *	1,9	
A	DE 31 35 292 A1 (LICENTIA GMBH [DE]) 24 March 1983 (1983-03-24) * figure 4 *	1	
A	JP H04 187190 A (MATSUSHITA ELECTRIC IND CO LTD) 3 July 1992 (1992-07-03) * abstract; figures 2-5 *	1-6	
A	JP S62 183795 A (MATSUSHITA ELECTRIC IND CO LTD) 12 August 1987 (1987-08-12) * figures 1-3 *	1,6	
A	JP S61 272097 A (MATSUSHITA ELECTRIC IND CO LTD) 2 December 1986 (1986-12-02) * figures 1-3 *	1-3,6	
A	WO 2005/049910 A1 (ARCELIK AS [TR]; BAHADIR AYDIN [TR]) 2 June 2005 (2005-06-02) * figures 4-6 *	1,6,7	TECHNICAL FIELDS SEARCHED (IPC) D06F
The present search report has been drawn up for all claims			
Place of search Munich		Date of completion of the search 31 July 2013	Examiner Kising, Axel
CATEGORY OF CITED DOCUMENTS X : particularly relevant if taken alone Y : particularly relevant if combined with another document of the same category A : technological background O : non-written disclosure P : intermediate document		T : theory or principle underlying the invention E : earlier patent document, but published on, or after the filing date D : document cited in the application L : document cited for other reasons & : member of the same patent family, corresponding document	

1
EPO FORM 1503 03.02 (P04C01)

ANNEX TO THE EUROPEAN SEARCH REPORT
ON EUROPEAN PATENT APPLICATION NO.

EP 13 15 0538

5

This annex lists the patent family members relating to the patent documents cited in the above-mentioned European search report. The members are as contained in the European Patent Office EDP file on The European Patent Office is in no way liable for these particulars which are merely given for the purpose of information.

31-07-2013

10

Patent document cited in search report	Publication date	Patent family member(s)	Publication date
EP 2423376 A1	29-02-2012	BR P11104209 A2	25-12-2012
		CN 102383296 A	21-03-2012
		EP 2423376 A1	29-02-2012
		US 2012049705 A1	01-03-2012

DE 102005013051 A1	21-09-2006	DE 102005013051 A1	21-09-2006
		DE 202006021101 U1	04-02-2013
		EP 1871945 A1	02-01-2008
		US 2008189973 A1	14-08-2008
		WO 2006097369 A1	21-09-2006

DE 3135292 A1	24-03-1983	NONE	

JP H04187190 A	03-07-1992	NONE	

JP S62183795 A	12-08-1987	JP H0734840 B2	19-04-1995
		JP S62183795 A	12-08-1987

JP S61272097 A	02-12-1986	NONE	

WO 2005049910 A1	02-06-2005	AT 527405 T	15-10-2011
		CN 1882737 A	20-12-2006
		EP 1704275 A1	27-09-2006
		RU 2338020 C2	10-11-2008
		TR 200602289 T1	26-10-2006
		WO 2005049910 A1	02-06-2005

15

20

25

30

35

40

45

50

55

EPO FORM P0458

For more details about this annex : see Official Journal of the European Patent Office, No. 12/82

REFERENCES CITED IN THE DESCRIPTION

This list of references cited by the applicant is for the reader's convenience only. It does not form part of the European patent document. Even though great care has been taken in compiling the references, errors or omissions cannot be excluded and the EPO disclaims all liability in this regard.

Patent documents cited in the description

- EP 1092802 A [0015]
- JP 5184515 B [0016]