

(19)



(11)

EP 2 762 781 A1

(12)

EUROPEAN PATENT APPLICATION

(43) Date of publication:
06.08.2014 Bulletin 2014/32

(51) Int Cl.:
F23C 10/10 (2006.01) **F23C 10/26** (2006.01)
F23C 10/32 (2006.01)

(21) Application number: **13382033.2**

(22) Date of filing: **01.02.2013**

(84) Designated Contracting States:
AL AT BE BG CH CY CZ DE DK EE ES FI FR GB GR HR HU IE IS IT LI LT LU LV MC MK MT NL NO PL PT RO RS SE SI SK SM TR
Designated Extension States:
BA ME

(72) Inventors:
• **Abanades Garcia, Juan Carlos**
28006 Madrid (ES)
• **Arias Rozada, Borja**
28006 Madrid (ES)
• **Alvarez Criado, Yolanda**
28006 Madrid (ES)

(71) Applicant: **Consejo Superior De Investigaciones Cientificas (CSIC)**
28006 Madrid (ES)

(74) Representative: **Pons Ariño, Angel**
Glorieta Ruben Dario 4
28010 Madrid (ES)

(54) **System and method for energy storage using circulating fluidized bed combustors**

(57) This invention relates to a system and a method for large scale energy storage in power generation systems using circulating fluidized bed combustors wherein the system can be further interconnected with another reactor that captures CO₂ with CaO, thereby enhancing the energy storage density in the system by using the enthalpy of the reversible reaction of CO₂ with CaO, wherein the system and the method of this invention are characterized by a large flexibility between periods of

maximum power output and complementary periods of low power output, wherein at maximum power output, a circulation of solids from a high temperature silo to a low temperature silo is established through the system of the invention and at minimum power output, part of the thermal energy released in the circulating fluidized bed combustor is used to heat up solids from the low temperature silo and store them in the high temperature silo.

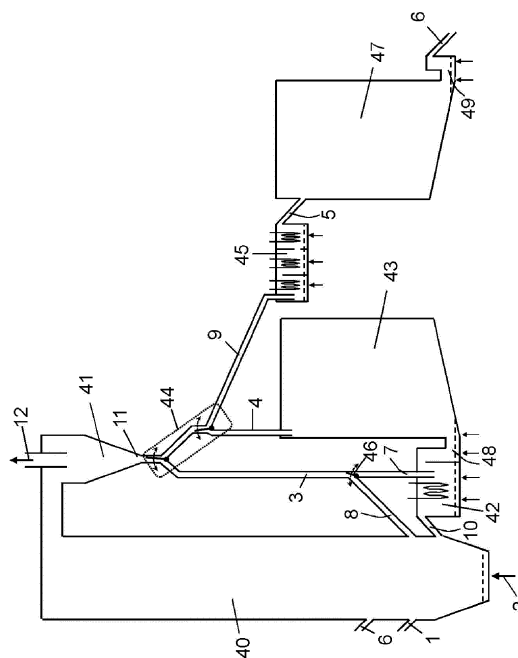

FIG. 1

EP 2 762 781 A1

Description**FIELD OF THE INVENTION**

[0001] This invention relates to a system and a method for large scale energy storage in power generation systems using circulating fluidized bed combustors fired with air, or fired with oxygen. This system can be further interconnected with another reactor that captures CO₂ with CaO, thereby enhancing the energy storage density in the system by using the enthalpy of the reversible reaction of CO₂ with CaO. The system and the method of this invention are characterized by a large flexibility between periods of maximum power output and complementary periods of low power output. At maximum power output, a circulation of solids from a high temperature silo to a low temperature silo is established through the system of the invention. At minimum power output, part of the thermal energy released in the circulating fluidized bed combustor is used to heat up solids from the low temperature silo and store them in the high temperature silo. In systems and methods capturing CO₂ with CaO, part of the thermal energy released during periods of maximum power output comes from the carbonation of CaO and in periods of low power output part of the thermal energy released during combustion is used to calcine CaCO₃ and store CaO.

DESCRIPTION OF THE PRIOR ART

[0002] According to the best science available, as reviewed by the Intergovernmental Panel of Climate Change, climate change is a physical reality and the signs of its negative consequences are increasingly obvious in many parts of the world. Aggressive climate change mitigation policies are needed to be able to decarbonising the global energy system and stabilize global warming below 2°C. All reasonable scenarios investigating possible paths to decarbonise the energy system with minimum cost predict a substantial penetration of renewable energy and CO₂ capture and storage technologies. The role of these options could be even more important when considering renewed difficulties to deploy nuclear in many countries.

[0003] Renewable energies still face large uncertainties on cost when deployed with a very high share of the total energy system, in particular when the energy product is electricity. One of the reasons for their high cost is that they are intermittent, and they need complex electricity transmission networks, electricity storage and/or back up infrastructures to adapt their supply curves to the demand curves. Although there is a major effort worldwide to develop technologies to store electricity at large scale, no economic solution has been generalized today. Therefore, in countries with a substantial contribution of renewables in the electricity mix, backup fossil power generation is used today to fill the time periods where renewable energy is not available. In these con-

ditions fossil energy has a lower priority to access the variable demand market of electricity and very rapid and drastic changes in power output are expected. Obviously, this scenario of low capacity factors of fossil power plants is far more expensive than an optimum situation where similar equipment operates in continuous or base-load mode of operation.

[0004] The previous problem will be exacerbated when considering the use of fossil fuels for power generation with CO₂ capture and permanent geological storage, CCS, which widely recognized as a major mitigation option of climate change. Power plants with CCS are complex, integrated systems that are inherently capital intensive, in particular when they are coal-based power generation. Therefore, for economic and technical reasons, power plants with CCS cannot be very flexible in their power output.

[0005] In this context, energy storage in fossil fuel power plants, with and without CCS, is an attractive technical option, as it would allow variability of the power outputs irrespective of the thermal power input. The idea of energy storage in fossil fuel power plants is not new. An early example in the state of the art of large scale energy storage in coal power plants is the report of Drost et al "Thermal energy storage for coal-fired power generation", MK Drost, S Somasundaram et al, Fossil Fuel Plant Cycling Conf. Washington, Dec 1990, where they describe a concept in which a coal-fired power plant heats a molten salt from 288°C to 566°C and store the salt in a high temperature tank during low electricity demand periods. During peak demand periods, the hot salt is withdrawn from the high temperature tank and used as a heat source for a steam generator returning the cold molten salt to a low temperature tank (at 288°C). This technology does not seem to have penetrated the market, probably because the cost associated to the thermal energy storage system is higher than the cost of the power plant equipment necessary to deliver the same variable thermal power.

[0006] It is a common practice in power plants to accommodate load changes, to as low as the combustion equipment allows from the maximum power output. However, the energy efficiency of the plant decreases drastically below a certain load level and the fugitive emissions of the plant deteriorate during these transient periods, as combustion is carried out away from optimum design conditions. If the demand of electricity is below this threshold, a shut down of the plant is necessary, followed by a hot start, a warm start or a cold start depending on the length of off line period of the plant (from a few hours to several days or weeks). Therefore, in today's power generation market, there is a substantial energy and economic penalty when the power generation equipment is forced to operate with load changes and offline periods. However, this economic penalty seems to be lower than the economic penalty associated to the investment on a large scale energy storage system in the power plant.

[0007] In new power generation systems incorporating CCS, the capital cost associated to the thermal power equipment is much higher than in the equivalent systems without CCS. Therefore, it is obvious that a wider economic window exist for the design of large scale energy storage systems in power plants incorporating CCS. This is already recognized in the state of the art, and all major technology options for CO₂ capture from power plants (postcombustion systems, oxy-combustion systems, or pre-combustion systems) are investigating process options that allow for large flexibility and drastic load changes (See for example: John Davison, "The need for flexibility in power plants with CCS", IEA Greenhouse Gas R&D Programme. Workshop on Operating Flexibility of Power Plants with CCS, London, 11th-12th Nov 2009). However, no cost-effective and generally accepted technical solution is yet available for the large scale energy storage in the different types of fossil power plants with or without a CO₂ capture system.

[0008] One particular type of large scale power plant makes use of Circulating fluidized bed combustors, CF-BC. These devices are widely deployed in the coal power sector and other large scale industries. They usually burn in their combustor chambers coal, biomass or other solid fuel with air. They are known to work at relatively large superficial velocities, which allow an effective transport of circulating solids through the combustor and a very intense mixing of solids that provides them with high heat transfer characteristics. One or several cyclones are usually installed at the exit of these combustors to separate the combustion flue gas from the circulating solids. Solids coming from the cyclone are recirculated in a large extent to the combustor. Heat released in the combustion can be partially recovered inside the combustion chamber (for example by transferring heat to water pipes that are part of a boiler of a steam cycle). It is also part of the state of the art to operate the combustor in adiabatic conditions and extract the excess heat from the combustor by using the circulating solids as heat carriers. In this case, an external fluidized bed heat exchanger is usually arranged in the return path of the circulating solids, to transfer part of their heat to a bank of tubes that is part of the steam cycle, and return the cooled solids to the combustion chamber. Circulating solids are typically fine ash and Ca-rich materials typically used for sulfur capture purposes. Equipment to handle and control solid flows (loop seals and other solid valves, equipment to divert falling flows of solid, etc) is also part of the state of the art of these and other large scale industries (i.e. power generation, cement, mineral roasting etc) that are familiar with the handling of flowing streams of solids at high temperatures.

[0009] Circulating fluidized bed combustor power plants using O₂ as a comburent, instead of air are also known in the state of the art. However, this is a technology still in the development stage, as related for example in patent application US20090293782 (A1).

[0010] It is also known a Ca-looping postcombustion

CO₂ capture system, where the flue gas from a power plant is first put in contact with CaO to absorb CO₂ and form CaCO₃ in a carbonator reactor, that emits a flue gas with a reduced content of CO₂. The stream of solids containing CaCO₃ is calcined in an oxyfired CFB combustor at a temperature around or above 900°C in an atmosphere of concentrated CO₂. The basic concept was described by T. Shimizu, et al "A twin bed reactor for removal of CO₂ from combustion processes", Trans I Chern E, 77A, 1999 and has experienced a fast development in recent years up to the MW scale (see for example Sanchez-Biezma et al, "Testing postcombustion CO₂ capture with CaO in a 1.7 MWt pilot facility", Energy Procedia 2013). Energy storage in these large scale CO₂ capture systems for power generation has never been considered in the state of the art. However, there is fundamental background in the state of the art (e.g. R. Barker, "The reversibility of the reaction CaCO₃ = CaO + CO₂", J. Appl. Chem. Biotechnol. 23 (1973) 733-742;) on the use of CaO/CaCO₃ reversible reaction to store energy from nuclear reactors. Newer schemes have been proposed for the storage of solar energy using the reversible carbonation-calcination reaction of the CaO/CaCO₃ chemical loop (S.E.B. Edwards, V. Materic, "Calcium looping in solar power generation plants", Volume 86, Issue 9, September 2012, Pages 2494-2503).

[0011] Silos allowing for storage of fine powdered solids at low temperature and at high temperature, and equipment to handle and control the solid streams coming in or out of the silo are also known.

[0012] Of particular interest for this invention are fluidized bed heat exchangers that extract heat from circulating solids at high temperature to a working fluid (for example water/steam mixture of a steam cycle for power generation). This kind of heat exchangers form part of CFBC power plants. These fluidized bed heat exchangers can be arranged in series for more efficient, counter-current flow heat transfer from the solids to the working fluid. A recent example of such an arrangement is a series of fluidized beds of sand to efficiently exchange heat from circulating sand at high temperature to a steam cycle (K. Schwaiger, M. Haider et al, sandTES - A novel Thermal Energy Storage System based on Sand, 21st international conference on Fluidized Bed Combustion, Naples, 2012).

[0013] Despite the commercial availability and existing prior art of specific systems and components for energy storage reviewed in the paragraphs above, there is today no system to efficiently and economically store large quantities of thermal and chemical energy in a large solid fuel power plant, with or without CCS. In particular, no technical solutions is available to exploit the energy storage potential of very high temperature solids abandoning a circulating fluidized bed combustor, an oxyfired circulating fluidized bed combustor or a Ca-looping system using high temperature solids coming from circulating fluidized bed combustors. The system of this invention provides a solution for this challenge and the methods

described in this invention allow for new coal based power generation systems with or without CO₂ capture that incorporate highly efficient means of large scale energy storage, making them much more economic and competitive in electricity markets where they are forced to operate with very high levels of flexibility and load changes.

SUMMARY OF THE INVENTION

[0014] This invention refers to a system and a method for large scale energy storage in power generation systems using circulating fluidized bed combustors fired with air, or fired with oxygen, to achieve novel power plant system configurations with a high flexibility to operate at different levels of thermal power output. The system and the method of this invention exploit the inherent thermodynamic benefits for efficient energy storage associated with the very high temperatures characteristic of the solids circulating in circulating fluidized bed combustion systems, CFBC. In addition, the system of this invention refers to CO₂ capture systems using a CaO/CaCO₃ chemical loop for CO₂ capture from flue gases that also uses high temperature circulating fluidized bed reactors. The use of the reversible CaO reaction with CO₂ to give CaCO₃, which has a very high enthalpy of reaction (-168 kJ/mol at normal conditions), allows for additional flexibility in the power output of the system presented in this invention.

[0015] The system is intended for the combustion of a fuel in a circulating fluidized bed combustor, preferably at typical temperatures of around 800-950°C (to allow for in situ SO₂ capture in the combustor), while incorporating large scale thermal energy storage comprising:

i) a circulating fluidized bed combustor with a first pipe for supplying a fuel and a second pipe for supplying a comburent through a gas distributor, the circulating fluidized bed combustor being connected to
 ii) a first cyclone for separating the resulting hot flue gas and the hot solids stream circulating to the circulating fluidized bed combustor,
 wherein the system further comprises;

iii) a first device for splitting solid streams falling by gravity from the first cyclone, directing the solids from the first cyclone

a) towards the circulating fluidized bed combustor through a third pipe,

b) towards a higher temperature silo that receives higher temperature solids through a fourth pipe, directing the solids from the higher temperature silo to a first fluidized bed heat exchanger, and

c) towards a lower temperature silo for storing lower temperature solids from a second fluidized bed heat exchanger, the lower temperature silo connected to the second fluidized bed heat ex-

changer by means of a fifth pipe and connected to the circulating fluidized bed combustor by means of a sixth pipe, and

iv) a first solid control device for controlling the feed of the higher temperature solids from the higher temperature silo.

v) a second control device for controlling the feed of the lower temperature solids from the lower temperature silo to the circulating fluidized bed combustor.

[0016] The system of the present invention exploits the high thermal energy content of the large solid circulation flow at high temperature characteristic of circulating fluidized bed combustors. The temperatures of the solids in the higher temperature silo are expected to be very close to those typical in the combustion chamber, between 800-950°C, preferably 850°C when the comburent is air. The higher temperature silo and/or the lower temperature silo are located between the minimum height of the cyclone and the lower point of the circulating fluidized bed combustion chamber, just above the gas distributor of such combustion chamber, so that circulation of the downwards part of the higher temperature circulation loop of the solids is facilitated by gravity and the upward part (riser) is simply carried out by the circulating fluidized bed combustion chamber.

[0017] The method of energy storage using circulating fluidized bed combustors of the present invention comprises the following stages:

i) feeding a flow of fuel and comburent to a circulating fluidized bed combustion chamber, separating the resulting hot flue gas and solids streams from the circulating fluidized bed combustion chamber, **characterized in that** the inputs of fuel, comburent and solid circulation through the circulating fluidized bed combustion chamber allow variable thermal power output by working between two operation modes:

a) a first operation mode of maximum power output with maximum flow of fuel and comburent to the circulating fluidized bed combustion chamber, where additional thermal power to the steam cycle is obtained extracting heat from the hot solids stream in a second fluidized bed heat exchanger directing the solids stream to a lower temperature silo where lower temperature solids are stored, by arranging higher temperature solids to flow from a higher temperature silo through the first fluidized bed heat exchanger cooling the higher temperature solids in a controlled way by means of a first solid control device disposed between the higher temperature silo and the first fluidized bed heat exchanger, and

b) a second operation mode of minimum power output with minimum flow of fuel and comburent to the circulating fluidized bed combustion

chamber where the thermal output from the first fluidized bed heat exchanger is zero and the lower temperature solids flow from the lower temperature silo towards the circulating fluidized bed combustion chamber in a controlled way by means of a second solid control device disposed between the lower temperature silo and the circulating fluidized bed combustion chamber so that the excess thermal power released in the circulating fluidized bed combustion chamber is transferred to the lower temperature solids so that the resulting higher temperature solids flow to the higher temperature silo, where the higher temperature solids are stored.

[0018] The previous method can be applied using circulating fluidized bed combustors that use air as a comburent. When integrated with a state of the art steam cycle, the resulting system would be a highly flexible CFBC power plant in which a fixed value of coal (or other fuel) could be set to enter the circulating fluidized bed combustor, and this power input could remain stable and unchanged following the method of this invention, despite large changes in the power output. Alternatively, in the second operation mode, minimum power output could be made even lower by reducing the flows of fuel and comburent within the normal limits of operation of the combustor, which can be about 50% of the maximum power output. The first operation mode of maximum power output from the power plant defines the scale of the steam cycle and associated power generation equipment. This can be freely chosen within certain limits that are governed by the mass and heat balances in the system, by the volume of the storing silos, by the bulk density and specific heat capacity of the solids, and by the temperature of the solids stored in the silos. In any case, the fraction of time per year operating at maximum power output, or alternatively, the fraction of energy generated during a certain period of time divided by the maximum possible energy generated during that period of time (called here the capacity factor) can vary greatly in this power plant without having to switch off the circulating fluidized bed combustor and associated components. When electricity market conditions request maximum power for relatively short periods of time (low capacity factors), the system and the method above described are able to supply with a relatively small circulating fluidized bed combustor the same maximum power output than a much higher combustor designed to supply the same maximum power output. This is achieved thanks to the boosting effect of the higher temperature solid storage system of the system of the present invention. Therefore, the application of the methods described so far in this invention will translate into economic savings respect to the standard CFBC systems when the capital cost of the additional elements required in the storage system (mainly the silos, the second heat exchanger, and associated auxiliary equipment) is lower than the difference

in capital cost between the standard CFBC to produce the same maximum power output and the system of the present invention. Further economic benefits in favour of the system of the present invention arise from the faster response expected in the system when fast load changes and/or pick demands of electricity need to be undertaken. This is because the circulating fluidized bed combustor in the present invention is always in operation at steady state conditions despite the large changes allowed in the power output. The stable conditions in the combustor will also lead to energy efficiency gains and environmental benefits as transient combustion conditions are avoided.

[0019] The previous benefits of the energy storage system disclosed in this invention are even more evident when applied to more capital intensive power generation systems. One of such systems can be an oxyfired Circulating Fluidized Bed Combustor power plant, designed to capture and store CO₂. These systems incorporate, among other elements, a costly Air Separation Unit to obtain a pure stream of O₂, auxiliary equipment for flue gas recycle and a Compression and Purification Unit to bring the CO₂ to supercritical conditions and allow transport and permanent geological storage, For these complex systems it is extremely difficult and/or expensive to operate in conditions different to full load operation and/or lower capacity factors. In these conditions, it will be a great cost advantage to make use of the system and method of this invention. Such system is similar to that represented in Figure 1, by making the comburent fed to circulating fluidized bed combustor a mixture of concentrated O₂ and CO₂. As discussed in previous paragraphs for the air-fired case, this new system will yield substantial capital savings and operational benefits from using a smaller and stable oxyfuel CFB combustor while being able to supply periods of maximum power output identical to those of a much large oxyfired CFBC system.

[0020] Another such a capital intensive system that can benefit from this invention because it also uses high temperature circulating fluidized bed reactors, is calcium looping systems that use CaO as a reversible sorbent to capture CO₂.

[0021] The previous descriptions and the associated examples are not restricted to operation modes of the system of this invention in extremes modes of operation only. Intermediate thermal power outputs can be obtained from the systems represented in Figure 1 by splitting the total flow of solids through the circulating fluidized bed combustor and the cyclone in different solid streams through the third, fourth and fifth pipes and allowing different flows of solids from the solid silos to the circulating fluidized bed combustor. In addition, a wide variability of temperatures can be considered in the silos depending of the number and efficiencies of the fluidized bed heat exchangers arranged in series. Many of these variants should be evident for a skilled person in the art attempting to attain a certain power output profile (power output at different times) among the extremes of maximum load of solids in the higher temperature silo and lower tem-

perature silo of the system of Figure 1.

[0022] The circulating solids can be a mixture of ash from the coal fed to the circulating fluidized bed combustor and calcium derived solids routinely used in CFBCs as a sorbents of SO₂ (the purge system of these ashes has been omitted for simplicity in Figure 1). However, in order to substantially minimize the volume of the silos, it will be beneficial to run the system of Figure 1 with a circulation of a low cost inert solid of high particle bulk densities. There could be many of these solids, stable at high temperatures and with suitable properties for fluidization, such as oxides of Al, Fe, Mn or Ti or mixed natural oxides like ilmenite or olivine. Ashes accumulated from the fuel combustion should be purged (not shown in the figure for simplicity) from these batch of dense solid circulating in the energy storage system of Figure 1.

BRIEF DESCRIPTION OF THE DRAWINGS

[0023] A set of drawings is attached wherein, with illustrative and non-limiting character, the following has been represented:

Figure 1: shows a general scheme of the first and second devices of this invention (air fired CFBC and oxyfired CFBC respectively) comprising the higher temperature and lower temperature silos, the fluidized bed heat exchangers and the solid control and splitting devices arranged in the characteristic manner of this invention.

Figure 2: shows a general scheme of the Calcium looping CO₂ capture system incorporating an energy storage system that can be operated in operating modes with different thermal power output without altering the combustion conditions in the oxyfired calciner.

Figure 3: shows a general scheme of the Calcium looping CO₂ capture system incorporating an energy storage system as in Figure 2, but with further operation modes, including an oxyfired calciner that can even operate as the device of Figure 1.

DETAILED DESCRIPTION OF THE PREFERRED EMBODIMENTS

[0024] This invention refers to a system and a method for large scale energy storage in power generation systems using circulating fluidized bed combustors fired with air, or fired with oxygen, to achieve novel power plant system configurations with a high flexibility to operate at different levels of thermal power output. The system and the method of this invention exploit the inherent thermodynamic benefits for efficient energy storage associated with the very high temperatures characteristic of the solids circulating in circulating fluidized bed combustion systems, CFBC. In addition, the system of this invention refers to CO₂ capture systems using a CaO/CaCO₃ chemical loop for CO₂ capture from flue gases that also uses

high temperature circulating fluidized bed reactors. The use of the reversible CaO reaction with CO₂ to give CaCO₃, which has a very high enthalpy of reaction (-168 kJ/mol at normal conditions) allows for additional flexibility in the power output of the system presented in this invention.

[0025] A first system disclosed in this invention is presented in Figure 1 and is intended for the combustion of a fuel in a circulating fluidized bed combustor at typical temperatures of around 800-950°C (usually 850°C to allow for in situ SO₂ capture in the combustor by CaO) while incorporating large scale thermal energy storage comprising:

- i) a circulating fluidized bed combustion chamber (40) with a first pipe (1) for supplying a fuel and a second pipe (2) for supplying a comburent through a gas distributor, the circulating fluidized bed combustion chamber (40) connected to a first cyclone (41) and a first fluidized bed heat exchanger (42) for receiving solids from the first cyclone (41) and/or from a higher temperature silo (43), wherein the first cyclone (41) separates the resulting hot flue gas (12) and hot solids stream (11) from the circulating fluidized bed combustion chamber (40),
- ii) a first device (44) for splitting solid streams falling by gravity from the first cyclone (41) directing the solids towards the first fluidized bed heat exchanger (42) that receives the high temperature solids through a third pipe (3), towards the higher temperature silo (43) that receives higher temperature solids through a fourth pipe (4), and towards a second fluidized bed exchanger (45) that receives higher temperature solids through a ninth pipe (9).

[0026] The solids from the first cyclone (41) may be directed to the first fluidized bed heat exchanger (42) connected to the circulating fluidized bed combustion chamber (40) by means of a second device (46) for splitting solid streams through a seventh pipe (7).

[0027] The system further comprises a bypass or eighth pipe (8) of the first fluidized bed heat exchanger (42) to be used during periods of low thermal load in the circulating fluidized bed combustion chamber (40), using the second device (46) for splitting solid streams (a diverter, a double loop seal or any other mechanical mean to divert solid flows).

[0028] The system further comprises:

- iii) at least a second fluidized bed heat exchanger (45) that can effectively transfer heat from the higher temperature solid stream to the steam cycle of the power plant, the second fluidized bed heat exchanger (45) connected to the first device (44) for splitting solid streams by means of a ninth pipe (9), and
- iv) a lower temperature silo (47) for storing lower temperature solids from the second fluidized bed heat exchanger (45), the lower temperature silo (47)

connected to the second fluidized bed heat exchanger (45) by means of a fifth pipe (5)

v) a first solid control device (48) to feed hot solids from the higher temperature silo (43) to the circulating fluidized bed combustion chamber (40) by means of a tenth pipe (10) that connects the first fluidized bed heat exchanger (42) to the circulating fluidized bed combustion chamber (40), and

vi) a second solid control device (49) to feed lower temperature solids from the lower temperature silo (47) to the circulating fluidized bed combustion chamber (40) by means of a sixth pipe (6).

[0029] The system of the present invention exploits the high thermal energy content of the large solid circulation flow at higher temperature characteristic of circulating fluidized bed combustors.

[0030] The arrangement of elements in the system of the present invention facilitates the handling and transport of large flows of very high temperature solid materials between silos. This is particularly relevant in the system of Figure 1, where temperatures of the solids in the higher temperature silo are expected to be very close to those typical in the combustion chamber (40), between 800-950°C, preferably 850°C to maximize the in situ SO₂ capture with CaO in the CFBC (40). The higher temperature silo (43) and/or the lower temperature silo (47) are located between the minimum height of the first cyclone (41) and the lower point of the circulating fluidized bed combustion chamber, just above the gas distributor of such combustion chamber (40), so that circulation of the downwards part of the higher temperature circulation loop of the solids is facilitated by gravity and the upward part (riser) is simply carried out by the circulating fluidized bed combustion chamber (40).

[0031] The method of energy storage using circulating fluidized bed combustors of the first system of present invention comprises the following stages:

i) feeding a maximum flow of fuel and comburent to a circulating fluidized bed combustion chamber (40), separating in a first cyclone (41) the resulting hot flue gas and solids streams from the circulating fluidized bed combustion chamber (40), and recovering part of the heat released in the fuel combustion by extracting heat from the hot solids stream in a first fluidized bed heat exchanger (42); or alternatively feeding a minimum flow of fuel and comburent to the circulating fluidized bed combustion chamber (40) and arranging for part or all of the circulating solids to bypass the first fluidized bed heat exchanger (42) wherein variable thermal power output is allowed while maintaining stable conditions in the circulating fluidized bed combustion chamber (40), by working between two operation modes:

a) a first operation mode of maximum power output with maximum flow of fuel and comburent to

the circulating fluidized bed combustion chamber (40), where additional thermal power to the steam cycle is obtained allowing all solids leaving the first cyclone (41) to flow through a second fluidized bed heat exchanger (45) directing the solids stream to a lower temperature silo (47), where lower temperature solids which heat is extracted are stored, while maintaining a flow of solids through the circulating fluidized bed combustion chamber (40) by arranging higher temperature solids to flow from a higher temperature silo (43) through the first fluidized bed heat exchanger (42) cooling the solids and feeding them to the circulating fluidized bed combustion chamber (40) in a controlled way by means of a first solid control device (48) disposed between the higher temperature silo (43) and the first fluidized bed heat exchanger (42), and

b) a second operation mode of minimum power output with minimum flow of fuel and comburent to the circulating fluidized bed combustion chamber (40) where the thermal output from the first fluidized bed heat exchanger (42) is zero by diverting solids through a bypass or eighth pipe (8) and the lower temperature solids are fed from a lower temperature silo (47) to the circulating fluidized bed combustion chamber (40) in a controlled way by means of a second solid control device (49) so that the excess thermal power released in the circulating fluidized bed combustion chamber (40) is transferred to the lower temperature solids so that the resulting higher temperature solids flow to the higher temperature silo (43), where the high temperature solids are stored.

[0032] A second system disclosed in this invention contains several common elements as those described above, but include several particular features that can make it even more economically attractive than those described above for large scale and flexible power generation from fossil fuels with CO₂ capture. The system concerned is represented in Figure 2 and is a system for CO₂ capture from a flue gas by calcium looping. As discussed in the state of the art, this is a CO₂ capture technology inherently more economic than the oxyfired CFB system that comprises:

i) a circulating fluidized bed carbonator (50) with a eleventh pipe (13) supplying a flue gas containing diluted CO₂, coming from an existing combustion power plant (not shown in Figure 2 for simplicity), just before this flue gas is sent to the stack. The carbonator reactor typically has a twelfth pipe (14) supplying solids rich in CaO from a circulating fluidized bed combustor (52) that is an oxyfired circulating fluidized bed calciner, (in order to increase the residence time and the total inventory of the solids in the

carbonator). The carbonator (50) is typically connected to a second cyclone (51) for separating the flue gas depleted in CO₂ (16) and the partially carbonated solid stream containing CaCO₃ (17) where-in part of the partially carbonated solids stream containing CaCO₃ (17) is recirculated to the circulating fluidized bed carbonator (50) through a thirteenth pipe (15) and the remaining stream of high temperature solids containing CaCO₃ is sent to the oxyfired circulating fluidized bed calciner (52),

ii) an oxyfired circulating fluidized bed combustor (52) operating as a calciner with a first pipe (18) supplying a fuel, a second pipe (19) supplying a mixture of O₂ and CO₂ through a gas distributor, a fourteenth pipe (20) supplying a stream of solids containing CaCO₃ that typically comes from the second cyclone (51). There is also a third pipe (21) supplying recirculated solids from the oxyfired circulating fluidized bed calciner (52) from a first cyclone (53) in order to increase the residence time and the inventory of solids in the oxyfired circulating fluidized bed calciner (52). The first cyclone (53) separates the CO₂ rich gas (22) from the calcined solid stream containing CaO (23). The CO₂ rich gas (22) coming from the oxyfired circulating fluidized bed calciner (52) will be connected downstream with all necessary equipment for efficient power generation and CO₂ conditioning and compression. Part of this CO₂ may be recycled to form part of the mixture of O₂ and CO₂ entering the gas distributor by means of the second pipe (19) together with the purified O₂ generated in an air separation unit (not shown in Figure 2 for simplicity),

iii) a first (55) and a third (54) devices for splitting the calcined solid stream containing CaO (23) and the partially carbonated solid stream containing CaCO₃ (17) respectively each into several solid streams. The third device (54) for splitting solid streams falling by gravity from the second cyclone (51) directs the solids

- a) towards the circulating fluidized bed carbonator (50) through the thirteenth pipe (15),
- b) towards the oxyfired circulating fluidized bed calciner (52) through the fourteenth pipe (20), and
- c) towards the lower temperature silo (57) for storing lower temperature solids through a fifth pipe (30) that connects a second fluidized bed heat exchanger (56) to the lower temperature silo (57).

The first device (55) for splitting the calcined solid stream containing CaO (23) falling by gravity from the first cyclone (53) directs the solids

- a) towards the oxyfired circulating fluidized bed calciner (52) through the third pipe (21),

b) towards a higher temperature silo (58) that receives high temperature solids through a fourth pipe (24), and

c) towards the circulating fluidized bed carbonator (50) by means of a fifteenth pipe (25),

iv) at least a third fluidized bed heat exchanger (59) to extract heat from the high temperature stream of solids containing CaO from the fifteenth pipe (25) before feeding them to the circulating fluidized bed carbonator (50) through the twelfth pipe (14). The working fluid extracting the heat from this fluidized bed will typically be part of a steam cycle of a power plant,

v) a sixteenth pipe (26) in the circulating fluidized bed carbonator (50) or in the oxyfired circulating fluidized bed calciner (52) to supply a CaCO₃ make up flow of fresh limestone that sustains the CO₂ carrying capacity of the CaO particles and compensate from CaO losses by attrition or sulfation. A seventeenth pipe (27) in the circulating fluidized bed carbonator (50) or in the oxyfired circulating fluidized bed calciner (52) is disposed to purge an equivalent flow of solids and avoid the accumulation of ashes and Calcium derived solids.

[0033] The device further comprises:

vi) a first solid control device (60) to feed higher temperature solids from the higher temperature silo (58) to a first fluidized bed heat exchanger (61) that discharges lower temperature solids rich in CaO to the circulating fluidized bed carbonator (50) through an eighteenth pipe (28), and

vii) a second solid control device (62) to feed solids from the lower temperature silo (57) to the oxyfired circulating fluidized bed calciner (52) through a sixth pipe (31).

[0034] The method of energy storage using circulating fluidized bed combustors, more preferably a method for CO₂ capture from a flue gas by calcium looping, using the second system described above as a calciner of CaCO₃ is disclosed in this invention, comprising the following stages:

i) feeding a flow of fuel and comburent to an oxyfired circulating fluidized bed calciner (52) to decompose CaCO₃ into a rich stream of CO₂ (22) and a calcined solid stream containing CaO (23),

ii) feeding a flow of flue gas containing CO₂ and a flow of solids containing CaO to a circulating fluidized bed carbonator (50) in conditions to allow an effective capture of CO₂ by CaO to form a partially carbonated solid stream containing CaCO₃ (17) and a flue gas with low concentration of CO₂ (16),

iii) recycling recirculated solids from the circulating fluidized bed carbonator (50) through the thirteenth

pipe (15), supplying a part of partially carbonated solid stream containing CaCO_3 (17) from the circulating fluidized bed carbonator (50), to increase residence time of solids in the circulating fluidized bed carbonator (50) and sending the remaining solid stream to the oxyfired circulating fluidized bed calciner (52) to decompose the CaCO_3 into a rich stream of CO_2 (22) and a calcined solid stream containing CaO (23),

iv) recycling recirculated solids from the oxyfired circulating fluidized bed calciner (52) through a third pipe (21) supplying part of the calcined solid stream containing CaO (23), to increase residence time of solids in the oxyfired circulating fluidized bed calciner (52) and sending the remaining stream of high temperature solids containing CaO by means of a fifteenth pipe (25) to a third fluidized bed heat exchanger (59) to cool the high temperature calcined solids containing CaO , and feeding these solids to the circulating fluidized bed carbonator (50), thereby starting again the CO_2 capture looping cycle.

[0035] As discussed in previous paragraphs for oxyfired CFBC power plants, the full CO_2 capture system is a complex and highly integrated system, and drastic changes in the power output are associated to technical and economic inefficiencies. It is particularly difficult to follow load changes with the oxy-fired circulating fluidized bed calciner (52), as this is connected to an air separation unit supplying pure O_2 and a full CO_2 purification and compression train of the CO_2 rich gas stream, part of which is recycled to the mixture stream of O_2 and CO_2 as part of the state of the art of oxyfired systems. The method of this invention provides a solution to uncouple the power output in the system from the operation conditions of the oxyfired circulating fluidized bed calciner of Figure 2 and be able to operate with different power outputs. The method is therefore **characterized in that** variable thermal power output is allowed while maintaining stable conditions in the circulating fluidized bed calciner (52), by working between the two extreme operation modes described for the first system and wherein:

a) the first operation mode of maximum power output further comprises the maximum flue gas flow to the circulating fluidized bed carbonator (50), where additional thermal power is obtained from the second fluidized bed heat exchanger (56) due to that the second fluidized bed heat exchanger (56) receives a higher temperature solids stream from a third device (54) for splitting the partially carbonated solids stream containing CaCO_3 (17) and delivers a lower temperature solid stream of carbonated solids through a fifth pipe (30) to the lower temperature silo (57) and additional thermal power is obtained from the first fluidized bed heat exchanger (61) that discharges lower temperature solids rich in CaO to the circulating fluidized bed carbonator (50) through a

eighteenth pipe (28).

[0036] In this situation, the CO_2 capture system is generating the thermal power of the fuel feed through the first pipe (18) plus the thermal power generated in the carbonation of the CaO reacting with the CO_2 or flue gas coming in the thirteenth pipe (13) plus the thermal power extracted from the high temperature solids flowing from the higher temperature silo (58) to the lower temperature silo (57). Obviously, this beneficial maximum power output scenario can only last until the high temperature CaO stored in the higher temperature silo (58) is depleted. In order to load the higher temperature silo (58) with high temperature calcined solids rich in CaO , it is necessary that during certain periods of time the system operates in conditions such that a surplus of thermal energy is available in the oxyfired circulating fluidized bed calciner to heat up and calcine an additional flow of solids respect to those coming after reacting with CO_2 in the circulating fluidized bed carbonator.

b) Therefore the second operation mode of minimum power output further comprises the minimum flue gas flow to the circulating fluidized bed carbonator (50) where the resulting excess in the thermal output in the oxyfired circulating fluidized bed calciner (52) is used to heat up and calcine an additional flow of cold and partially carbonated solids from the lower temperature silo (57), regulated with the second solid control device (62) and a CaCO_3 make up flow of fresh limestone through a sixteenth pipe (26), so that a flow of hot and CaO rich solids through a fourth pipe (24) is stored in the higher temperature silo (58).

[0037] A new device is disclosed (Figure 3) that is similar to the described for Figure 2 but wherein the second device (63) for splitting recirculated solids from the oxyfired circulating fluidized bed calciner (52) through third pipe (21) also connects the first cyclone (53) to a fourth heat exchanger (64) through a seventh pipe (32). This fourth heat exchanger (64) is further connected to the oxyfired circulating fluidized bed calciner (52).

[0038] The system further comprises a fourth device (65) for splitting solid streams that directs the solids abandoning the first fluidized bed heat exchanger (61) to the circulating fluidized bed combustor (52) or to the circulating fluidized bed carbonator (51).

[0039] This allows for a new method for CO_2 capture in this device further comprising the extraction of heat from the oxyfired circulating fluidized bed calciner (52) through a fourth heat exchanger (64) wherein different thermal power outputs are allowed between the following extremes while maintaining stable conditions in the oxyfired circulating fluidized bed calciner (52) by working between the two extreme operation modes described for the second system and wherein:

a) in the first operation mode of maximum power

output the oxyfired circulating fluidized bed calciner (52) operates as an oxyfired fluidized bed combustor re-circulating CaO solids from the oxyfired circulating fluidized bed calciner (52) through a seventh pipe (32) to maximize power output in a fourth heat exchanger (64) while allowing sufficient higher temperature CaO rich solids from the higher temperature silo (58) to flow through the first fluidized bed heat exchanger (61) in order to feed lower temperature solids rich in CaO to the circulating fluidized bed carbonator (50) through the eighteenth pipe (28) and partially carbonate the solids in the presence of the flue gas coming in the eleventh pipe (13), and directing the solids leaving the circulating fluidized bed carbonator (50) through the second fluidized bed heat exchanger (56) to be cooled and stored in the lower temperature silo (57);

[0040] In this situation, the CO₂ capture system is generating the thermal power of the fuel feed through the first pipe (18) of the oxyfired circulating fluidized bed calciner (52) plus the thermal power generated in the carbonation of the CaO reacting with the CO₂ coming in the eleventh pipe (13) plus the thermal power extracted from the high temperature solids flowing from the higher temperature silo (58) to the lower temperature silo (57). Obviously, this additional and beneficial maximum power output scenario is at the expense of larger silos and larger oxyfired circulating fluidized bed calciner (52) than when operating with the device of Figure 2. The maximum power output can only last until the high temperature CaO stored in the higher temperature silo (58) is depleted. In order to charge the higher temperature silo (58) with high temperature calcined solids rich in CaO, it is necessary to operate during certain periods of time in conditions such that a surplus of thermal energy is available in the calciner to heat up and calcine an additional flow of solids respect to those coming after reacting with CO₂ in the circulating fluidized bed carbonator, and

b) therefore, the second operation mode of minimum power output, further comprises a reduced flow of flue gas coming in the eleventh pipe (13) and a bypass of the fourth heat exchanger (64) through the eighth pipe (33) to the oxyfired circulating fluidized bed calciner (52) that allows for an excess thermal output in the an oxyfired circulating fluidized bed calciner (52) that is used to heat up and calcine an additional flow of cold and partially carbonated solids from the lower temperature silo (57), regulated with the second solid control device (62), so that a flow of hot and CaO rich solids through the fourth pipe (24) is stored in the higher temperature silo (58).

[0041] A further advantage of this method is that due to the larger oxyfired circulating fluidized bed calciner size, the time period required to operate at the second operation mode of minimum power output can be mini-

mized.

[0042] Example 3 illustrates other technical benefits of this method, related to the much higher flexibility in power outputs and wider choice of operation modes when the oxyfired circulating fluidized bed calciner (52) can be operated as an independent power plant not linked to the a circulating fluidized bed carbonator (50), or even as an independent power plant capable of operating as discussed above for the device of Figure 1. This refers to a scenario where the solids from the oxyfired circulating fluidized bed calciner (52) are all directed to the second fluidized bed heat exchanger (56) connected to the lower temperature silo (57) by means of the ninth pipe (34), and the solids abandoning the first fluidized bed heat exchanger (61) are directed to the oxyfired circulating fluidized bed calciner (52) instead of being directed to the circulating fluidized bed carbonator (50), by means of a fourth device (65) for splitting solid streams.

[0043] The previous methods best operate with the highest temperature difference between higher temperature silo and the lower temperature, leading to lower volume silos for the same quantity of energy stored. Temperatures close to the temperature in the combustion chambers 850-950° are suitable for the higher temperature silo, preferably around 850°C for the air-fired combustors and 900°C for the oxyfired combustors. The temperature of the cold solids depends on the number and efficiency of fluidized bed heat exchangers arranged in series, and will typically be between 150-400° C, preferably around 200°C.

[0044] The previous methods can further reduce their second operation mode of minimum power output and/or the time required to operate at this second operation mode of minimum power output by further transferring heat to the solids coming from the lower temperature silo, by using heat from the high temperature flue gas streams leaving the circulating fluidized bed reactors. This can be achieved with cyclones arranged in series such as those used in commercial precalciners of limestone in cement plants.

[0045] There will be other ways to operate the devices of this invention that will be obvious for the skilled in the art in view of the devices and methods disclosed in this invention. For example, it will be evident to a skilled in the art to connect device of Figure 1 with the devices of Figure 2 or 3 by making the flue gas stream (12) to be the stream of flue gas (13) in Figure 2 and 3. The resulting system will open a wider range of operating modes, that would add even more flexibility to power plants with CO₂ capture using the devices of this invention. Similar devices and principles can be designed following the teachings of this invention for precombustion CO₂ capture systems using CaO as a regenerable sorbent, systems where the calcination heat is coming from an exothermic reaction taking place in parallel to the calcination reaction or systems where the heat for calcination is coming from a solid heat carrier or a metallic wall connecting the calciner to a high temperature combustion chamber or to

other high temperature source of heat. Also, following the teaching of this invention, it is possible to adapt the devices and methods of this invention to other chemical looping systems that use circulating fluidized bed reactors at high temperatures and highly exothermic gas solid reactions, like for example the oxidation of a metal with air. Therefore, the description and examples provided in this invention are illustrative and of non-limiting character.

EXAMPLES

EXAMPLE 1. Design example of the device of Figure 1

[0046] A conceptual design of the device of Figure 1 is carried out below to illustrate its practical application and the flexibility to obtain a variety of power outputs. Let us first assume a maximum thermal power input by combustion in the fluidized bed combustion chamber (40) of 100 MWth and a typical temperature in the fluidized bed combustion chamber (40) of 850 °C when combustion is carried out with air (2). Let's also choose typical dimensions for a combustion chamber of this order of thermal power output in commercial equipment: a cross section of 20 m² and a height of 40 m. These fluidized bed combustion chambers usually have water heat exchangers in their interior, but it is better to adopt for the device of this invention an adiabatic design, that is also part of the state of the art. To simplify the mass and heat balances in the example, we are assuming here that 75% of the heat produced during the combustion of fuel in the fluidized bed combustion chamber (40) is extracted from the system in the first fluidized bed heat exchanger (42) and 25% abandons the system as sensitive heat in the flue gas (12) leaving the first cyclone (41). If we assume an average heat capacity of the solids circulating in the system of 1.3 kJ/kg°C and a typical solid circulation rate of solids through the combustion chamber of 10 kg/sm² (kg per second and per square meter of cross-sectional area of the fluidized bed combustion chamber (40)), the temperature drop of the solids in the first fluidized bed heat exchanger (42), required to close the heat balance is 288.5 °C. This is consistent with the state of the art operation of commercial CFBC power plants.

[0047] Let us now assume a reasonable size for the higher temperature silo (43) and the lower temperature silo (47) arranged as in Figure 1. Assuming they have a height of 20 meters and 40 m² of cross-section, which is the double of the cross-section of the fluidized bed combustion chamber (40) and yields an identical volume. Let us also assume a temperature of the higher temperature solids in the higher temperature silo (43) of 850 °C and 200 °C of the cold solids in the lower temperature silo (47), and a bulk density of the solids in the silos of 1500 kg/m³. This allows storing a maximum amount of solids of 1.2*10⁶ kg, with a total heat storage equivalent to 282 MWt. In principle, this quantity of heat could be extracted from these solids at a very high rate in their pass from the higher temperature silo (43) to the lower temperature

silo (47), for example by arranging an additional heat exchanger (not shown in Figure 1 for simplicity) between the higher temperature silo (43) and the lower temperature silo (47). This could yield a very large thermal power output by reducing the solid transfer time with a large circulation flow of solids between silos. However, this would require unrealistically large heat exchanger devices and associated power generation equipment operating only during very short periods of time. Therefore, more modest and realistic thermal power outputs are likely to be the target of design. These targets could be achieved allowing a direct circulation of solids from the higher temperature silo (43) to the lower temperature silo (47). But this would still require an additional heat exchanger (not shown in the Figure 1) between the higher temperature silo (43) and the lower temperature silo (47) and also require practical solutions to arrange a circulation of high temperature solids between the two silos. This solution could end up being also complex and costly. However, the device of this invention, makes use of the existing circulating fluidized bed combustor to facilitate the solid circulation between the higher temperature silo (43) and the lower temperature silo (47) in modes of maximum thermal output with reasonable circulation rates established between the higher temperature silo (43) and the lower temperature silo (47). To illustrate this, it is fixed in this example the solid circulation rate through the combustor at 10 kg/m²s allowing for a certain fraction of this solid circulation to come from the flow of solids established between the higher temperature silo (43) and the lower temperature silo (47). For example, if the power input from the fuel combustion remains at 100 MWt in the fluidized bed combustion chamber (40) and all the temperatures are to remain also constant, the total heat extraction in the first fluidized bed heat exchanger (42) must be also constant. In these conditions, the maximum power output mode, correspond to a flow of solids from the higher temperature silo (43) to the fluidized bed combustion chamber (40) and to the lower temperature silo (47) of 2.8 kg/m²s (55.6 kg/s in the example) and an additional power output 47 MWt is accomplished in the second fluidized bed heat exchanger (45) by cooling the solid stream from 850 to 200 °C. According to the size of the silos chosen for this example, this maximum power output mode can be maintained during 6 hours until all the hot solids stored in the higher temperature silo (43) are transferred to the lower temperature silo (47). Longer periods for this maximum can obviously be achieved with larger silos or larger differences in solid temperatures between the higher temperature silo (43) and the lower temperature silo (47). It is also evident that longer periods of operation at more modest values of the maximum power output can be achieved, by allowing larger changes in solid circulation rates (that can change typically between 1 to 20 kg/m²s in commercial CFBC without relevant design changes in the solid circulation system). A change in solid circulation rate of solids through the fluidized bed combustion chamber (40) may also require a change of

thermal output in the first fluidized bed heat exchanger (42), and this can be done by using commercial heat exchanger equipment available to operate with variable thermal loads or by using the split of solids that bypasses the first fluidized bed heat exchanger (42) to arrange for a certain direct recirculation of solids from the first cyclone (41) to the fluidized bed combustion chamber (40). For example, with the same total solid circulation in the fluidized bed combustion chamber (40) as above (10 kg/m²s or 200 kg/s), a split in the first device (44) for splitting solid streams of the solids falling by gravity from the first cyclone (41) of 144 kg/s towards the third pipe (3) and the first fluidized bed heat exchanger (42) allows for the required solid circulating from the higher temperature silo (43) to the lower temperature silo (47) while maintaining solid circulation rates and combustion conditions identical with and without energy storage. Therefore, designing the above system to deliver its maximum power output for 6 continuous hours, results into a maximum power output of 147 MWt (100 MWt from combustion and 47 MWt from the second fluidized bed heat exchanger (45) in the novel energy storage system).

[0048] The time at maximum power must be balance by a certain time at minimum power output, where the target is to fill up the silo of high temperature solids. Furthermore, conditions of minimum power output are likely to be associated with situations where the combustion chamber is working at minimum load (for example at night time). For circulating fluidized bed combustors this can be as low as 50%. Therefore, during the period of minimum power output of this particular example we assume 50 MWt as energy input from combustion in the fluidized bed combustion chamber (40). For simplicity we assume again that 25% of this power abandons the combustor in the flue gas leaving the first cyclone (41). This leaves 37.5 MWt available to heat up to 850°C the solids circulating from lower temperature silo (47) (at 200 °C) to the fluidized bed combustion chamber (40). This requires a control with the second control device (49) of a solid flow of 44.4 kg/s going through the sixth pipe (6) (or 2.2 kg/m²s in the fluidized bed combustion chamber (40)) and a split of the same solid flow of solids from the first cyclone (41) to the higher temperature silo (43) through the fourth pipe (4). If a higher solid circulation rate was required to maintain fluidization conditions and heat transfer within the fluidized bed combustion chamber (40), this additional circulation flow could be obtained by allowing a split of solids in the first device (44) for splitting solid streams falling by gravity from the first cyclone (41) and recirculating solids from the first cyclone (41) to the fluidized bed combustion chamber (40) through the third pipe (3) without passing through the first fluidized bed heat exchanger (42). For the size of the silos chosen for this example, the minimum operation mode has to be maintained during 7.5 hours, until all the lower temperature solids stored in the lower temperature silo (47) are transferred to the higher temperature silo (43). This time could be shortened by arranging an additional method to pre-

heat with the flue gas (12) leaving the first cyclone (41) the solids coming from the lower temperature silo (47) before they enter the fluidized bed combustion chamber (40). This could be carried out with commercial equipment to rise the lower temperature solids stored in the lower temperature silo (47) and put them in contact with the hot flue gas (12) leaving the first cyclone (41) in additional cyclones in series (not shown in the Figure for simplicity), as it is common practice in precalciners and preheaters of solids being fed to cement production plants.

[0049] The maximum time (6.0 h) at the maximum power output defined in this particular example and the minimum time at minimum power output (7.5 h) are values chosen for this particular example. Many intermediate values are possible and will be evident for the skilled in the art. The remaining hours (10.5 h) to complete a full day operation time could be used in this particular example at the reference conditions of 100 MWt. This would yield a capacity factor of the plant of 0.57. This capacity factor could be further reduced by operating a much longer time at low power output. For example, operating 6 h at maximum power output of 147 MWt and the remaining 18 h at a power output of 34 MWt, the capacity factor would be 0.43. Even lower capacity factor is possible by operating the fluidized bed combustion chamber (40) at minimum power input (50 MWt) in both the maximum and minimum power periods. This could be achieved by reducing the circulation flow from the lower temperature silo (47) to the higher temperature silo (43) and increasing accordingly (if necessary) the recycle of solids from the first cyclone (41) to fluidized bed combustion chamber (40) through the flue gas and the first fluidized bed heat exchanger (42). It can be estimated with simple mass and heat balances that for this particular example, any value of capacity factor between 0.34 and 0.68 is allowed without changing the dimension and operating conditions chosen for the example. Furthermore, it will be evident for the skilled in the art to define other volume of the storage silos, solid densities of the circulating solids, operating temperatures, or solid circulation rates, leading to different capacity factor intervals.

[0050] At this point, it is illustrative in this particular example of realization of the invention to compare the device and methods of the invention against a standard power plant giving the same maximum power outputs and with an identical capacity factor (measured here as a daily basis for simplicity). Such a power plant would have a thermal power from coal of 147 MWt and it is therefore 47% larger in every element of equipment related to the combustion chamber. Let's also assume that this plant is also requested to deliver during 6 hours a maximum power output of 147 MWt, that it is also allowed to go down by 50% in its thermal output and that it is requested by the market to operate with a particular capacity factor of 0.43 as in the paragraphs above. In these conditions, it will be evident for a skilled in the art that this power plant will be forced to be switched off (power

output equal zero) during at least 9.6 hours per day, in order to fulfil the maximum power requirements during a certain time and the low demand of power during other periods of time. The need to switch on and off the large combustion equipment of the fluidized bed combustion chamber (40), together with all the associated auxiliaries (coal and sorbent feeding systems, flue gas cleaning equipment etc are also switched off) is a clear disadvantage of the state of the art systems respect to the device and methods of this invention. As illustrated in this example, the device of this invention delivers the same maximum power and has the same capacity factor than the standard power plant, but it has a combustion chamber and associated auxiliaries to the combustion chamber that are about 50% smaller than in the standard plant. Furthermore, the device of this invention is operating the combustion chamber (40) with continuous flows of coal and air (the same at full load or at intermediate loads) as it does not require changes in such a combustion chamber (40) to accommodate low average capacity factors. These are both great advantages that are most likely going to compensate for the additional capital cost associated to the silos (43) (47) and the second fluidized bed heat exchanger (45), that are the most costly novel components in the device of this invention when compared to the standard power plant.

[0051] A skilled in the art will realize immediately than the previous example is also illustrative, with small modifications in the assumptions, to a reference zero emission power plant based on the oxy-fuel combustion in a circulating fluidized bed. However, the benefits of the device of this invention will be exacerbated because the reference plant contains in this case more complex and costly components (air separation unit, CO₂ purification, recycle and compression of CO₂ etc) that have dimensions proportional to the thermal combustion power released in (40). Also, these complex and integrated components make more difficult and expensive the operations of switching on and off the power plant.

EXAMPLE 2. Design example of the device of Figure 2

[0052] A conceptual design of the device of Figure 2 is carried out below to illustrate its practical application and the flexibility to obtain a variety of power outputs from the Calcium Looping system represented in the figure. Let us first assume a maximum thermal power input by combustion in the oxyfired circulating fluidized bed calciner (52) of 100 MWt and a temperature of 900 °C when combustion is carried out with a certain mixture of O₂ and CO₂. This temperature should be sufficient for calcination of CaCO₃, as the reactor is assumed to operate at atmospheric pressure and with a certain content of steam. Let's also assume a total solid circulation rate of solids entering the oxyfired circulating fluidized bed calciner (52) of 200 kg/s as in the combustion chamber (40) of Example 1. It is important that this oxyfired circulating fluidized bed calciner (52) is designed adiabatically to

maximize the use for calcination of the thermal input associated to the fuel combustion (and minimize the O₂ requirements and its associated energy and economic penalties). To simplify the mass and heat balances in this example, we are assuming here that 80% of the heat produced during the combustion of fuel introduced in the oxyfired circulating fluidized bed calciner (52) by means of the first pipe (18) is used for calcination and for heating up to calcination temperature the solid entering the oxyfired circulating fluidized bed calciner (52).

[0053] Let us now assume an identical volume of the lower temperature silo (57) and the higher temperature silo (58) as in Example 1 arranged as in Figure 2, identical bulk density of the solids (1500 kg/m³), and temperatures of the hot solids in the higher temperature silo (58) of 900 °C and 200 °C of the cold solids in lower temperature silo (57). Let's also assume a heat capacity of the solids of 1 kJ/kg as they are composed mainly of CaO. This allows a thermal energy heat storage equivalent to 233.3 MWt in the higher temperature silo (58). The solids in stored in the higher temperature silo (58) are assumed to be 90 weight % CaO in this particular example. This content in free CaO and its associated maximum activity or CO₂ carrying capacity will depend on many factors that are well known in the state of the art of Calcium looping systems. In the lower temperature silo (57), the solids are carbonated in a certain level of conversion X, that is defined as the carbonate conversion or mol fraction of CaO converted to CaCO₃. The enthalpy of the carbonation reaction is -168 kJ/mol. In the process to fill the lower temperature silo (57) with carbonated solids originally in the higher temperature silo (58), there has been a carbonation process in the circulating fluidized bed carbonator (50) releasing 900X MWt. For the purpose of the mass and heat balance in this example, this can be considered an additional energy stored in the higher temperature silo (58). The value of X is set by a mass balance on the circulating fluidized bed carbonator (50). We assume here a maximum flue gas rate containing 0.40 kmol/s of CO₂, which is equivalent to the flue gas emitted by a 180 MWt power plant. If we assume a target of 90% CO₂ capture efficiency a maximum flow of CaCO₃ leaving the circulating fluidized bed carbonator (50) is established at 0.36 kmol/s.

[0054] As discussed in Example 1, a very large thermal power output could be achieved from this system by reducing the solid transfer time (with a large circulation flow of solids between silos) between the higher temperature silo (58) to the circulating fluidized bed carbonator (50) and through the cyclone (51) and through the second fluidized bed heat exchanger (56) and through the lower temperature silo (57). This large solid circulation could be established simultaneously to the capture of 90% of the CO₂ in the flue gas in the eleventh pipe (13) set as a target, as the typical solid circulation rate set in the circulating fluidized bed carbonator (50) and oxyfired circulating fluidized bed calciner (52) is sufficient to capture all the necessary CO₂ in the circulating fluidized bed car-

bonator (50) with modest carbonate conversion values, X. However, this would require unrealistically large heat exchangers (56, 61), and associated power generation equipment to these heat exchange devices would be operating only during very short periods of time. Therefore, more modest and realistic thermal power outputs are likely to be the target of economic design. The device of this invention, makes use of the existing circulating fluidized bed calciner (52) and circulating fluidized bed carbonator (50) to facilitate the solid circulation between the higher temperature silo (58) and the lower temperature silo (57) in modes of maximum thermal output with reasonable circulation rates established between the higher temperature silo (58) and the lower temperature silo (57) through the circulating fluidized bed carbonator (50). To illustrate this, it is calculated from the mass and heat balances for the particular conditions chosen for this example, and searching for a 6 hours period at maximum power output, a total solid flow entering the carbonator of 192.3 kg/s, coming 136.7 kg/s from the calciner (52) and 55.6 kg/s from the higher temperature silo (58). In these conditions, the maximum power output is 155.5 MWt and the value of X is 0.117 for a 90% CO₂ capture efficiency. As noted above, for the size of the silos chosen for this example, this maximum power output mode can be maintained during 6.0 hours until all the hot CaO rich solids stored in the higher temperature silo (58) are transferred to the lower temperature silo (57) after carbonating to a conversion X. Longer periods for this maximum can obviously be achieved with larger silos or larger differences in solid temperatures between the higher temperature silo (58) and the lower temperature silo (57). It is also evident that longer periods of operation at more modest values of the maximum power output can be achieved, by allowing lower solid circulation rates. However, the reduction in this solid circulation rate is limited by the CO₂ carrying capacity of the CaO solids in the circulating fluidized bed carbonator (50). It does not seem reasonable from the state of the art on Ca-looping to expect carbonation conversions higher X=0.20. Therefore, a minimum flow of CaO rich solids of 112 kg/s is required to enter the circulating fluidized bed carbonator (50) in this particular example. When operating with this minimum solid circulation rate and activity of the solids, the power output is 118.3 MWt.

[0055] The time of 6 hours set at the maximum power in the previous paragraph must be balanced by a certain time at lower power output, where the target is to fill up the higher temperature silo (58) of high temperature solids, while maintaining the CO₂ capture efficiency at 90% in the circulating fluidized bed carbonator (50). A surplus of thermal power in the calciner (52) is required for this purpose. The higher the surplus of thermal power, the minimum time will be required to operate at minimum thermal output in the Ca-looping system. These conditions of minimum power output are likely to be associated with situations where the combustion chamber supplying the flue gas to the circulating fluidized bed carbonator

(50) is working at minimum load (for example at night time). Assuming again that this flue gas stream can go down as much as 50% in periods of low power output, the capture of 90% of the 0.20 kmol/s of CO₂ entering the circulating fluidized bed carbonator (50) requires a minimum circulation of 96.1 kg/s for a carbonation conversion of 0.117. This allows for a surplus of energy in the calciner of 43.7 MWt which can be used to heat up and calcine a solid flow of 48.8 kg/s from the lower temperature silo (57). Under these conditions, an operation time of 7.2 h is needed to fill the higher temperature silo (58) with hot calcined solids. When operating in these conditions, the power output of the device is 53.8 MWt. The maximum time (6.0 h) at the maximum power output defined in this particular example and the minimum time at minimum power output (7.2 h) are values chosen for this particular example. Many intermediate values are possible and will be evident for the skilled in the art. The remaining hours (10.8) to complete a full day operation time could be used in this particular example at the reference conditions of 100 MWt. This would yield a capacity factor of the plant of 0.64. Different average capacity factors can be calculated for this system following a similar methodology as the one explained in Example 1.

[0056] At this point, it is illustrative in this particular example of realization of the invention to compare the device and methods of the invention against a standard Ca-looping system giving the same maximum power and with identical capacity factor of 0.64. Such a Ca-looping system would have a calciner with a thermal power from coal of 155.5 MWt which is more than 55% larger than in the device of this invention. All equipment associated to the calciner (in particular the complex and costly air separation unit to supply O₂) would also be 55% larger. In addition, if this plant was requested to operate with a similar capacity factor of 0.64, for example delivering during at least 6 hours a maximum power output of 155.5 MWt, this could only be possible by going down by 50% in its thermal output during at least 15.4 hours. Clearly, the device of this invention does not require changes in the combustion conditions in the oxy-fuel fluidized bed calciner, even when the flow of flue gas entering the carbonator changes within certain limits. In contrast, the standard calcium looping configuration requires complex load changes in the oxyfired calciner to follow the required global changes in power output.

[0057] For simplicity in the description of this particular example, we have not discussed the opportunities that the device of Figure 2 provides to establish internal solid recycles in both reactors and the intermediate situations that can be achieved by modulating the split of solids in the third (54) and first (55) devices for splitting the solid streams falling by gravity from the first or second cyclone (53, 51) towards a lower and higher temperature silo (57, 58) respectively. It should be obvious for a skilled in the art, and from the discussion in the Example 1, how to take benefit from this possibility to split solid flows between reactors and silos in order to gain more flexibility

in the operation of the system without altering the conditions in the calciner (52) and associated O₂ generation equipment.

EXAMPLE 3. Design example of the device of Figure 3

[0058] A conceptual design of the device of Figure 3 is carried out below to illustrate its practical application and the flexibility to obtain a variety of power outputs from the Calcium Looping system represented in the figure. Since there is a clear similarity of this device respect to the one described in example 2, we focus in this example only on the key difference between devices, associated to the possibility to operate the device of Figure 3 in a maximum power output mode where the oxyfired calciner is operating as an oxyfired CFB power plant independently of the circulating fluidized bed carbonator (50), extracting combustion heat from the fourth heat exchanger (64) using the second device (63) for splitting recirculated solids from the oxyfired circulating fluidized bed calciner (52) while feeding the circulating fluidized bed carbonator (50) with stored CaO in the higher temperature silo (58). Let us assume a maximum thermal power input by combustion in the oxyfired circulating fluidized bed calciner (52) of 100 MWt and an identical power output that is the sum of the sensitive heat power in the CO₂ rich gas (22) leaving the first cyclone (53) and the thermal power extracted in the fourth heat exchanger (64) by diverting all the circulating solids leaving the oxyfired circulating fluidized bed calciner. Let's now assume a solid and flue gas flows through the circulating fluidized bed carbonator (50) and a conversion X of CaO in the circulating fluidized bed carbonator (50) and CO₂ capture efficiencies identical to the ones for Example 2. However, in this case, all the solids arriving to the carbonator are coming from the higher temperature silo (58) and being stored in the lower temperature silo (57) at identical temperatures and carbonate conversion as in Example 2. In these conditions, a total power output of 292 MWt is obtained, which is the sum of the thermal power obtained from the combustion of the coal (100 MWt) in the oxyfired circulating fluidized bed calciner (52), and the remaining 192 MWt are the thermal power output from the first fluidized bed heat exchanger (61), from the second fluidized bed heat exchanger (56) and from the flue gas leaving the circulating fluidized bed carbonator (16). This high level of power output could only be maintained during 1.7 hours for the dimension and solid properties given in Example 2. Longer times at lower maximum power output can be chosen for the design following the methodology of Example 1. Clearly, a skilled in the art will realize by conducting these preliminary designs that the device of Figure 3 offers more flexibility and variations in operation and in power outputs, thanks to the fourth heat exchanger (64) connecting the first cyclone (53) to the oxyfired circulating fluidized bed calciner (52) and the possibility to operate the oxyfired circulating fluidized bed calciner (52) in oxycalcination mode or in oxycombustion mode. However,

these favourable modes of operation require a larger calciner (52) for the same amount of flue gas to be treated in the circulating fluidized bed carbonator (50) during periods of maximum power output.

[0059] The device of Figure 3 also offers higher flexibility when requested to deliver minimum power outputs. For example, in an extreme but realistic scenario the carbonator reactor and the associated power plant feeding the flue gas to the circulating fluidized bed carbonator (50) could be switched off, while the oxyfired circulating fluidized bed calciner (52) could still be operating in minimum oxycombustion mode and by-passing the and feeding solids from the lower temperature silo (57) to the oxyfired circulating fluidized bed calciner (52) and storing the resulting calcined higher temperature solid stream in the higher temperature silo (58). The design methodology described in previous examples could be used to estimate these minimum modes of power output, that greatly increase the flexibility of the CO₂ capture system of Figure 3 in terms of power output while allowing stable combustion conditions in the oxyfired circulating fluidized bed calciner (52)

Claims

1. System for large scale energy storage in a power generation system comprising:

- i) a circulating fluidized bed combustor (40, 52) with a first pipe (1, 18) for supplying a fuel and a second pipe (2, 19) for supplying a comburent through a gas distributor, the circulating fluidized bed combustor (40, 52) being connected to
 ii) a first cyclone (41, 53) for separating the resulting hot flue gas (12, 22) and the hot solids stream (11, 23) circulating to the circulating fluidized bed combustor (40, 52)

characterized in that the system further comprises:

- iii) a first device (44, 55) for splitting solid streams falling by gravity from the first cyclone (41, 53) directing the solids from the first cyclone (41, 53)

- a) towards the circulating fluidized bed combustor (40, 52) through a third pipe (3, 21),
 b) towards a higher temperature silo (43, 58) that receives higher temperature solids through a fourth pipe (4, 24), directing the solids from the higher temperature silo (43, 58) to a first fluidized bed heat exchanger (42, 61), and
 c) towards a lower temperature silo (47, 57) for storing lower temperature solids from a second fluidized bed heat exchanger (45, 56), the lower temperature silo (47, 57) connected to the second fluidized bed heat exchanger (45, 56) by means of a fifth pipe (5,

- 30) and connected to the circulating fluidized bed combustor (40, 52) by means of a sixth pipe (6, 31), and
- iv) a first solid control device (48, 60) for controlling the feed of the higher temperature solids from the higher temperature silo (43, 58), and
- v) a second control device (49, 62) for controlling the feed of the lower temperature solids from the lower temperature silo (47, 57) to the circulating fluidized bed combustor (40, 52).
2. System for large scale energy storage in a power generation system according to claim 1 **characterized in that** further comprises a second device (46) for splitting the hot solids stream from the first cyclone (41) to the first fluidized bed heat exchanger (42) through a seventh pipe (7) or to a bypass or eighth pipe (8) to the circulating fluidized bed combustion chamber (40) during periods of low thermal load in the circulating fluidized bed combustion chamber (40).
 3. System for large scale energy storage in a power generation system according to any of the previous claims **characterized in that** the first device (44) for splitting solid streams falling by gravity from the first cyclone (41) directs the solids towards the second fluidized bed exchanger (45) through a ninth pipe (9).
 4. System for large scale energy storage in a power generation system according to any of the previous claims **characterized in that** the first solid control device (48) controls the feed of hot solids from the higher temperature silo (43) to the circulating fluidized bed combustion chamber (40) through the first fluidized bed heat exchanger (42) by means of a tenth pipe (10) that connects the first fluidized bed heat exchanger (42) to the circulating fluidized bed combustion chamber (40).
 5. System for large scale energy storage in a power generation system according to claim 1 wherein the system is a system for CO₂ capture from a flue gas by calcium looping **characterized in that** the system for large scale energy storage further comprises
 - i) a circulating fluidized bed carbonator (50) with a eleventh pipe (13) supplying a flue gas containing diluted CO₂ and a twelfth pipe (14) supplying solids rich in CaO from the circulating fluidized bed combustor (52) that is an oxyfired circulating fluidized bed combustor operating as a calciner being connected to
 - ii) a second cyclone (51) for separating the flue gas depleted in CO₂ (16) and the partially carbonated solids stream containing CaCO₃ (17) wherein part of the partially carbonated solids stream containing CaCO₃ (17) is recirculated to the circulating fluidized bed carbonator (50) through a thirteenth pipe (15) and the remaining stream of high temperature solids containing CaCO₃ is sent to the oxyfired circulating fluidized bed calciner (52)
 6. System for large scale energy storage in a power generation system according to claim 5 **characterized in that** the first pipe (18) of the oxyfired circulating fluidized bed calciner (52) supplies a fuel, the second pipe (19) supplies a mixture of O₂ and CO₂ comburent through the gas distributor and a fourteenth pipe (20) supplies the partially carbonated solid stream containing CaCO₃ (17) coming from the second cyclone (51).
 7. System for large scale energy storage in a power generation system according to claim 6 **characterized in that** further comprises a third device (54) for splitting the partially carbonated solids stream containing CaCO₃ (17) falling by gravity from the second cyclone (51) directing the solids from the second cyclone (51)
 - a) towards the circulating fluidized bed carbonator (50) through the thirteenth pipe (15),
 - b) towards the oxyfired circulating fluidized bed calciner (52) through the fourteenth pipe (20), and
 - c) towards the lower temperature silo (57) for storing lower temperature solids through the fifth pipe (30) that connects the second fluidized bed heat exchanger (56) to the lower temperature silo (57).
 8. System for large scale energy storage in a power generation system according to any of the claims 5-7 **characterized in that** the first device (55) for splitting the hot solids stream (23), that is calcined and contains CaO, towards the lower temperature silo (57), makes it through the circulating fluidized bed carbonator (50) by means of a fifteenth pipe (25).
 9. System for large scale energy storage in a power generation system according to claim 8 **characterized in that** further comprises at least a third fluidized bed heat exchanger (59) to extract heat from the calcined solids stream containing CaO from the fifteenth pipe (25) before feeding them to the circulating fluidized bed carbonator (50) through the twelfth pipe (14).
 10. System for large scale energy storage in a power generation system according to any of the claims 5-9 **characterized in that** further comprises a sixteenth pipe (26) in the circulating fluidized bed carbonator (50) or in the oxyfired circulating fluidized bed cal-

- ciner (52) to supply a CaCO₃ make up flow of fresh limestone.
11. System for large scale energy storage in a power generation system according to any of the claims 5-10 **characterized in that** further comprises a seventeenth pipe (27) disposed in the circulating fluidized bed carbonator (50) or in the oxyfired circulating fluidized bed calciner (52) to purge an equivalent flow of solids and avoid the accumulation of ashes and Calcium derived solids. 5
 12. System for large scale energy storage in a power generation system according to any of the claims 5-11 **characterized in that** the first fluidized bed heat exchanger (61) discharges lower temperature solids rich in CaO to the circulating fluidized bed carbonator (50) through a eighteenth pipe (28). 10
 13. System for large scale energy storage in a power generation system according to any of claims 5-12 **characterized in that** further comprises a second device (63) for splitting recirculated solids from the oxyfired circulating fluidized bed calciner (52) through the third pipe (21) connecting the first cyclone (53) to a fourth heat exchanger (64) through a seventh pipe (32), fourth heat exchanger (64) further connected to the the oxyfired circulating fluidized bed calciner (52). 15
 14. System for large scale energy storage in a power generation system according to any of claims 5-13 **characterized in that** further comprises a fourth device (65) for splitting solid streams that directs the solids abandoning the first fluidized bed heat exchanger (61) to the circulating fluidized bed combustor (52) or to the circulating fluidized bed carbonator (50). 20
 15. System for large scale energy storage in a power generation system according to any of claims 5-14 **characterized in that** comburent (19) is a mixture of O₂ and recycled CO₂. 25
 16. Method of energy storage using circulating fluidized bed combustors comprising the following stages: 30
 - i) feeding a flow of fuel and comburent to a circulating fluidized bed combustion chamber (40, 52), separating the resulting hot flue gas (12, 22) and solid streams (11, 23) from the circulating fluidized bed combustion chamber (40, 52), **characterized in that** the inputs of fuel, comburent and solid circulation through the circulating fluidized bed combustion chamber (40, 52) allow variable thermal power output by working between two operation modes: 35
 17. Method of energy storage using circulating fluidized bed combustors according to claim 16 wherein the method is a method for CO₂ capture from a flue gas by calcium looping, **characterized in that** the method of energy storage further comprises the following stages; 40
 - a. a first operation mode of maximum power output with maximum flow of fuel and comburent to the circulating fluidized bed combustion chamber (40, 52), where additional thermal power to the steam cycle is obtained extracting heat from the hot solids stream in a second fluidized bed heat exchanger (45, 56) directing the solids stream to a lower temperature silo (47, 57) where lower temperature solids are stored, by arranging higher temperature solids to flow from a higher temperature silo (43, 58) through a first fluidized bed heat exchanger (42, 61) cooling the higher temperature solids in a controlled way by means of a first solid control device (48, 60) disposed between the higher temperature silo (43, 58) and the first fluidized bed heat exchanger (42, 61), and 45
 - b. a second operation mode of minimum power output with minimum flow of fuel and comburent to the circulating fluidized bed combustion chamber (40, 52) where the thermal output from the first fluidized bed heat exchanger (42, 61) is zero and the lower temperature solids flow from the lower temperature silo (47, 57) towards the circulating fluidized bed combustion chamber (40, 52) in a controlled way by means of a second solid control device (49, 62) disposed between the lower temperature silo (47, 57) and the circulating fluidized bed combustion chamber (40, 52) so that the excess thermal power released in the circulating fluidized bed combustion chamber (40, 52) is transferred to the lower temperature solids so that the resulting higher temperature solids flow to the higher temperature silo (43, 58), where the higher temperature solids are stored. 50
 17. Method of energy storage using circulating fluidized bed combustors according to claim 16 wherein the method is a method for CO₂ capture from a flue gas by calcium looping, **characterized in that** the method of energy storage further comprises the following stages; 55
 - i) feeding a flow of flue gas containing CO₂ and a flow of solids containing CaO to a circulating fluidized bed carbonator (50) in conditions to allow an effective capture of CO₂ by CaO to form a partially carbonated solid stream containing CaCO₃ (17) and a flue gas with low concentration of CO₂ (16),
 - ii) recycling recirculated solids from the circulating fluidized bed carbonator (50) through the thirteenth pipe (15), supplying a part of partially

carbonated solid stream containing CaCO_3 (17) from the circulating fluidized bed carbonator (50), to increase residence time of solids in the circulating fluidized bed carbonator (50) and sending the remaining solid stream to the oxy-fired circulating fluidized bed calciner (52) to decompose the CaCO_3 into a rich stream of CO_2 (22) and a calcined solid stream containing CaO (23),

iii) recycling recirculated solids from the oxy-fired circulating fluidized bed calciner (52) through a third pipe (21) supplying part of the calcined solid stream containing CaO (23), to increase residence time of solids in the oxy-fired circulating fluidized bed calciner (52) and sending the remaining stream of high temperature solids containing CaO by means of a fifteenth pipe (25) to a third fluidized bed heat exchanger (59) to cool the high temperature calcined solids containing CaO , and feeding these solids to the circulating fluidized bed carbonator (50), thereby starting again the CO_2 capture looping cycle, wherein the circulating fluidized bed combustor (52) is an oxy-fired circulating fluidized bed calciner and wherein

a. the first operation mode of maximum power output further comprises the maximum flue gas flow to the circulating fluidized bed carbonator (50), where additional thermal power is obtained from the second fluidized bed heat exchanger (56) due to that the second fluidized bed heat exchanger (56) receives a higher temperature solids stream from a third device (54) for splitting the partially carbonated solids stream containing CaCO_3 (17) and delivers a lower temperature solid stream of carbonated solids through a fifth pipe (30) to the lower temperature silo (57) and additional thermal power is obtained from the first fluidized bed heat exchanger (61) that discharges lower temperature solids rich in CaO to the circulating fluidized bed carbonator (50) through an eighteenth pipe (28), and

b. the second operation mode of minimum power output further comprises the minimum flue gas flow to the circulating fluidized bed carbonator (50) where the resulting excess in the thermal output in the oxy-fired circulating fluidized bed calciner (52) is used to heat up and calcine an additional flow of cold and partially carbonated solids from the lower temperature silo (57), regulated with the second solid control device (62) and a CaCO_3 make up flow of fresh limestone through a sixteenth pipe (26), so that a flow of hot and CaO rich solids through

a fourth pipe (24) is stored in the higher temperature silo (58).

18. Method of energy storage using circulating fluidized bed combustors according to claim 17 **characterized in that** it further comprises the stage of extraction of heat from the oxy-fired circulating fluidized bed calciner (52) through a fourth heat exchanger (64), and wherein

a. in the first operation mode of maximum power output the oxy-fired circulating fluidized bed calciner (52) operates as an oxy-fired fluidized bed combustor re-circulating CaO solids from the oxy-fired circulating fluidized bed calciner (52) through seventh pipe (32) to maximize power output in a fourth heat exchanger (64) while allowing sufficient higher temperature CaO rich solids from the higher temperature silo (58) to flow through the first fluidized bed heat exchanger (61) in order to feed lower temperature solids rich in CaO to the circulating fluidized bed carbonator (50) through the eighteenth pipe (28) and partially carbonate the solids in the presence of the flue gas coming in the eleventh pipe (13), and directing the solids leaving the circulating fluidized bed carbonator (50) through the second fluidized bed heat exchanger (56) to be cooled and stored in the lower temperature silo (57), and

b. the second operation mode of minimum power output further comprises a reduced flow of flue gas coming in the eleventh pipe (13) and a bypass of the fourth heat exchanger (64) through the eighth pipe (33) to the oxy-fired circulating fluidized bed calciner (52) that allows for an excess thermal output in the an oxy-fired circulating fluidized bed calciner (52) that is used to heat up and calcine an additional flow of cold and partially carbonated solids from the lower temperature silo (57), regulated with the second solid control device (62), so that a flow of hot and CaO rich solids through the fourth pipe (24) is stored in the higher temperature silo (58).

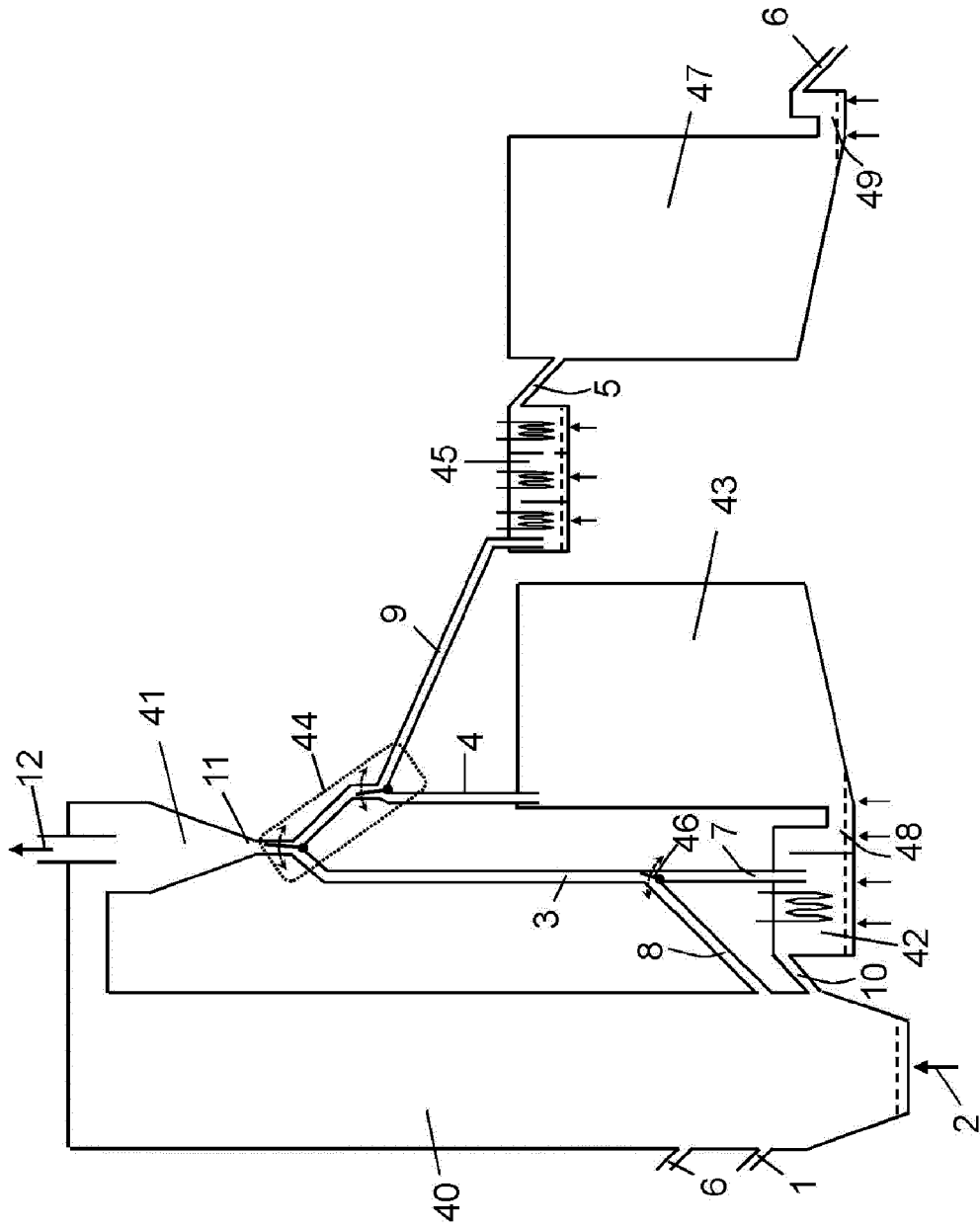
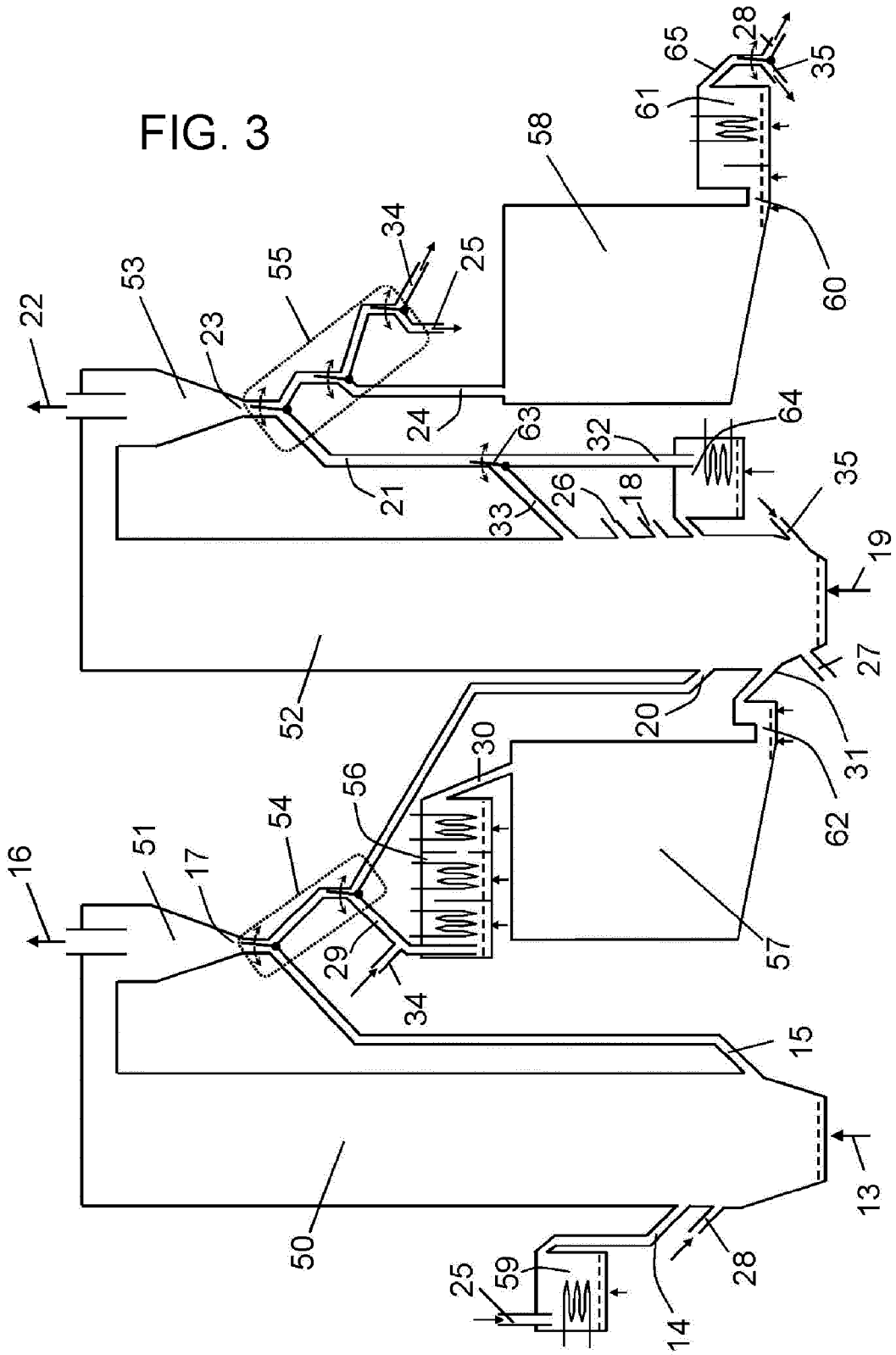

FIG. 1

FIG. 3





EUROPEAN SEARCH REPORT

Application Number
EP 13 38 2033

5

10

15

20

25

30

35

40

45

50

55

DOCUMENTS CONSIDERED TO BE RELEVANT			
Category	Citation of document with indication, where appropriate, of relevant passages	Relevant to claim	CLASSIFICATION OF THE APPLICATION (IPC)
A	WO 98/28570 A1 (COMBUSTION ENG [US]) 2 July 1998 (1998-07-02) * page 21, line 16 - line 26 * * page 22, line 20 - page 25, line 2 * * figure 1 *	1,16	INV. F23C10/10 F23C10/26 F23C10/32
A	EP 0 118 931 A1 (METALLGESELLSCHAFT AG [DE]) 19 September 1984 (1984-09-19) * page 9, paragraph 2 - paragraph 2 * * figure 1 *	1,16	
A	US 4 716 856 A (BEISSWENGER HANS [US] ET AL) 5 January 1988 (1988-01-05) * column 7, line 10 - column 8, line 42 * * figure 1 *	1,16	
A	US 5 069 170 A (GORZEGNO WALTER P [US] ET AL) 3 December 1991 (1991-12-03) * column 4, line 32 - column 5, line 25 * * figure 1 *	1,16	
A	US 2009/151902 A1 (JACOBS ROBERT V [US] ET AL) 18 June 2009 (2009-06-18) * page 3, paragraph 31 - page 4, paragraph 36 * * figure 1 *	1,16	TECHNICAL FIELDS SEARCHED (IPC) F23C
A	US 2009/211500 A1 (ANDRUS JR HERBERT E [US] ET AL) 27 August 2009 (2009-08-27) * page 3, paragraph 31 - page 5, paragraph 57 * * figure 1 *	1,16	
A	WO 2012/150987 A1 (SOUTHERN COMPANY [US]; VIMALCHAND PANNALAL [US]; LIU GUOHAI [US]; PENG) 8 November 2012 (2012-11-08) * page 19, line 27 - page 20, line 22 * * figure 2 *	1,16	
The present search report has been drawn up for all claims		-/--	
Place of search Munich		Date of completion of the search 19 April 2013	Examiner Gavriliu, Costin
CATEGORY OF CITED DOCUMENTS X : particularly relevant if taken alone Y : particularly relevant if combined with another document of the same category A : technological background O : non-written disclosure P : intermediate document		T : theory or principle underlying the invention E : earlier patent document, but published on, or after the filing date D : document cited in the application L : document cited for other reasons & : member of the same patent family, corresponding document	

EPO FORM 1503 03.82 (P04C01)



EUROPEAN SEARCH REPORT

Application Number
EP 13 38 2033

5

10

15

20

25

30

35

40

45

50

55

DOCUMENTS CONSIDERED TO BE RELEVANT			
Category	Citation of document with indication, where appropriate, of relevant passages	Relevant to claim	CLASSIFICATION OF THE APPLICATION (IPC)
A	WO 2004/097297 A1 (CANADA NATURAL RESOURCES [CA]; CONSEJO SUPERIOR INVESTIGACION [ES]; AN) 11 November 2004 (2004-11-11) * page 7, line 23 - page 10, line 12 * * figure 1 * -----	1,16	
			TECHNICAL FIELDS SEARCHED (IPC)
The present search report has been drawn up for all claims			
Place of search Munich		Date of completion of the search 19 April 2013	Examiner Gavriliu, Costin
CATEGORY OF CITED DOCUMENTS X : particularly relevant if taken alone Y : particularly relevant if combined with another document of the same category A : technological background O : non-written disclosure P : intermediate document		T : theory or principle underlying the invention E : earlier patent document, but published on, or after the filing date D : document cited in the application L : document cited for other reasons & : member of the same patent family, corresponding document	

EPO FORM 1503 03.82 (PC/MC01)

ANNEX TO THE EUROPEAN SEARCH REPORT
ON EUROPEAN PATENT APPLICATION NO.

EP 13 38 2033

5

This annex lists the patent family members relating to the patent documents cited in the above-mentioned European search report. The members are as contained in the European Patent Office EDP file on
The European Patent Office is in no way liable for these particulars which are merely given for the purpose of information.

19-04-2013

10

15

20

25

30

35

40

45

50

55

Patent document cited in search report	Publication date	Patent family member(s)	Publication date
WO 9828570 A1	02-07-1998	AU 5590398 A	17-07-1998
		CZ 9902266 A3	14-03-2001
		HU 0000417 A2	28-05-2000
		ID 24756 A	03-08-2000
		PL 334227 A1	14-02-2000
		RO 119162 B1	30-04-2004
		US 5784975 A	28-07-1998
		WO 9828570 A1	02-07-1998
EP 0118931 A1	19-09-1984	AU 561208 B2	30-04-1987
		BR 8400848 A	09-10-1984
		CA 1204274 A1	13-05-1986
		DE 3307848 A1	06-09-1984
		EP 0118931 A1	19-09-1984
		GR 79825 A1	31-10-1984
		IN 160853 A1	08-08-1987
		JP H0341729 B2	25-06-1991
		JP S59197724 A	09-11-1984
		US 4539188 A	03-09-1985
		ZA 8401593 A	30-10-1985
		US 4716856 A	05-01-1988
DE 3688007 D1	22-04-1993		
EP 0206066 A2	30-12-1986		
US 4716856 A	05-01-1988		
US 5069170 A	03-12-1991	CA 2037251 A1	02-09-1991
		EP 0444926 A2	04-09-1991
		ES 2096620 T3	16-03-1997
		JP 2657854 B2	30-09-1997
		JP H05231614 A	07-09-1993
		MX 171753 B	11-11-1993
US 5069170 A	03-12-1991		
US 2009151902 A1	18-06-2009	CN 101896770 A	24-11-2010
		EP 2217856 A1	18-08-2010
		TW 200938772 A	16-09-2009
		US 2009151902 A1	18-06-2009
		WO 2009076046 A1	18-06-2009
US 2009211500 A1	27-08-2009	AU 2009219351 A1	03-09-2009
		CA 2712870 A1	03-09-2009
		CN 101960218 A	26-01-2011
		CN 102159888 A	17-08-2011
		EP 2268974 A2	05-01-2011
		JP 2011513689 A	28-04-2011

EPO FORM P0459

For more details about this annex : see Official Journal of the European Patent Office, No. 12/82

ANNEX TO THE EUROPEAN SEARCH REPORT
ON EUROPEAN PATENT APPLICATION NO.

EP 13 38 2033

5

This annex lists the patent family members relating to the patent documents cited in the above-mentioned European search report. The members are as contained in the European Patent Office EDP file on
The European Patent Office is in no way liable for these particulars which are merely given for the purpose of information.

19-04-2013

10

Patent document cited in search report	Publication date	Patent family member(s)	Publication date
		JP 2011513690 A	28-04-2011
		US 2009211500 A1	27-08-2009
		US 2009211503 A1	27-08-2009
		WO 2009108737 A2	03-09-2009
		WO 2009108739 A2	03-09-2009

WO 2012150987 A1	08-11-2012	US 2013055936 A1	07-03-2013
		WO 2012150987 A1	08-11-2012

WO 2004097297 A1	11-11-2004	AU 2003222696 A1	23-11-2004
		CA 2522461 A1	11-11-2004
		EP 1618335 A1	25-01-2006
		JP 4355661 B2	04-11-2009
		JP 2006524790 A	02-11-2006
		US 2007056487 A1	15-03-2007
		WO 2004097297 A1	11-11-2004

15

20

25

30

35

40

45

50

55

EPO FORM P0459

For more details about this annex : see Official Journal of the European Patent Office, No. 12/82

REFERENCES CITED IN THE DESCRIPTION

This list of references cited by the applicant is for the reader's convenience only. It does not form part of the European patent document. Even though great care has been taken in compiling the references, errors or omissions cannot be excluded and the EPO disclaims all liability in this regard.

Patent documents cited in the description

- US 20090293782 A1 [0009]

Non-patent literature cited in the description

- **DROST ; MK DROST ; S SOMASUNDARAM et al.** Thermal energy storage for coal-fired power generation. *Fossil Fuel Plant Cycling Conf.*, 1990 [0005]
- **T. SHIMIZU et al.** A twin bed reactor for removal of CO₂ from combustion processes. *Trans I Chem E*, 1999, 77A [0010]
- **SANCHEZ-BIEZMA et al.** Testing postcombustion CO₂ capture with CaO in a 1.7 MWt pilot facility. *Energy Procedia*, 2013 [0010]
- **R. BARKER.** The reversibility of the reaction $\text{CaCO}_3 = \text{CaO} + \text{CO}$. *J. Appl. Chem. Biotechnol.*, 1973, vol. 23, 733-742 [0010]
- **S.E.B. EDWARDS ; V. MATERIC.** Calcium looping in solar power generation plants, September 2012, vol. 86 (9), 2494-2503 [0010]
- **K. SCHWAIGER ; M. HAIDER et al.** sandTES - A novel Thermal Energy Storage System based on Sand. *21st international conference on Fluidized Bed Combustion*, 2012 [0012]