

(19)



(11)

**EP 2 807 307 B1**

(12)

**EUROPEAN PATENT SPECIFICATION**

(45) Date of publication and mention of the grant of the patent:  
**13.07.2016 Bulletin 2016/28**

(51) Int Cl.:  
**E02D 27/42<sup>(2006.01)</sup>**

(21) Application number: **13703907.9**

(86) International application number:  
**PCT/NL2013/050037**

(22) Date of filing: **24.01.2013**

(87) International publication number:  
**WO 2013/112049 (01.08.2013 Gazette 2013/31)**

(54) **PILE FOR A WIND MOTOR**

PFAHL FÜR WINDGENERATOR

PIEUX POUR UNE ÉOLIÈNNE

(84) Designated Contracting States:  
**AL AT BE BG CH CY CZ DE DK EE ES FI FR GB GR HR HU IE IS IT LI LT LU LV MC MK MT NL NO PL PT RO RS SE SI SK SM TR**

(30) Priority: **24.01.2012 NL 2008169**

(43) Date of publication of application:  
**03.12.2014 Bulletin 2014/49**

(73) Proprietor: **Fistuca B.V.**  
**1018 VV Amsterdam (NL)**

(72) Inventor: **WINKES, Jasper Stefan**  
**NL-1018 VV Amsterdam (NL)**

(74) Representative: **Haan, Raimond et al**  
**Arnold & Siedsma**  
**Bezuidenhoutseweg 57**  
**2594 AC The Hague (NL)**

(56) References cited:  
**DE-U1-202007 009 474 US-A- 1 746 848**

**EP 2 807 307 B1**

Note: Within nine months of the publication of the mention of the grant of the European patent in the European Patent Bulletin, any person may give notice to the European Patent Office of opposition to that patent, in accordance with the Implementing Regulations. Notice of opposition shall not be deemed to have been filed until the opposition fee has been paid. (Art. 99(1) European Patent Convention).

## Description

**[0001]** The invention relates to a pile-driver, and more particularly to a pile-driver suitable for offshore operations such as generally known from US 1746848 A1.

**[0002]** In addition, the invention relates to a method for driving a pile downward into the ground using such a pile-driver.

**[0003]** Drawbacks of existing pile-drivers, particularly for offshore pile-driving, lie in the fact that such pile-drivers are very heavy structures. In offshore applications they are operated by large vessels with heavy cranes provided thereon. The piles are driven one by one into the ground.

**[0004]** The pile-driving itself usually takes place by dropping a ram forming part of a pile hammer onto the pile from some height via a striker plate. Typical properties of such a pile hammer for striking a monopile for the purpose of offshore wind turbines are a length of about 15 m and a mass of about 140 tons (with a drop block of 60 tons), as well as an associated striker plate of about 150-200 tons. The impact of the falling drop block drives a pile into the ground but is accompanied by a considerable noise production. This noise production is particularly undesirable in offshore operations, since sound carries very far in water and may thereby disrupt marine life a great distance away from the pile-driving location.

**[0005]** An object of the present invention is to provide a pile-driver and method for applying thereof, wherein said drawbacks do not occur, or do so to at least lesser extent.

**[0006]** Said objective is achieved with the pile-driver according to the invention, comprising:

- a support member arranged or arrangeable in transverse direction at or on a pile;
- at least one flexible member situated above and close to the support member and enclosing a combustion space of variable volume;
- an ignition mechanism adapted to ignite a fuel present in the combustion space; and
- wherein the combustion space is adapted to expand during combustion such that a medium located above the support member is displaced at least in upward direction away therefrom and a downward force is thereby exerted on the pile via the support member.

**[0007]** The operating principle is based on Newton's third law: "action = reaction". In other words: when an object A exerts a force on an object B, this force is accompanied by an equal but opposite force of B on A. During expansion the combustion space (object A) exerts a force on the medium located thereabove (reaction mass B). According to Newton's third law, the reaction mass (B) exerts an equal but opposite (so downward) force on the combustion space (A). Because the combustion space is located above and close to the support

member, the reaction force exerted by the reaction mass on the combustion space will be transmitted via the support member to the pile. The pile hereby undergoes a downward force via the support member, which is utilized according to the invention for the purpose of driving the pile downward into the ground.

**[0008]** In addition, the medium displaced upward during expansion of the combustion space will drop downward again and collide with the support member, where it once again exerts a downward force on the pile via the support member. This operating principle corresponds to the operation of conventional pile-drivers, wherein a drop block is dropped from some height onto the pile.

**[0009]** Because a conventional pile-driver is not required according to the invention, it is possible to drive a plurality of piles substantially simultaneously. Driving a plurality of piles for a wind farm at sea can hereby take place in a significantly reduced period of time, this being particularly advantageous for marine life, which is exposed to noise nuisance resulting from the pile-driving for a much shorter period of time.

**[0010]** In contrast to the typical steel-on-steel impact sound of conventional pile-driving, the pile-driving process according to the invention is accompanied by another type of sound which is less harmful to marine life.

**[0011]** A further advantage of a conventional pile-driver being unnecessary is that such a heavy structure with correspondingly suitable vessel is unnecessary. It suffices to place a pile using a crane suitable for the purpose and correspondingly suitable vessel, and to drive the pile only partially into the ground, after which the vessel with the crane can be replaced by a smaller vessel. This is particularly advantageous, since operation of such a large vessel with conventional pile-driver involves considerable cost.

**[0012]** Excessive groundwater pressure may occur after pile-driving. This needs time to even out, after which further driving can take place in order to impart sufficient load-bearing capacity to the pile. Where, with a conventional pile-driving technique, a large vessel has to wait for the excessive groundwater pressure to even out, this is unnecessary in the pile-driving system according to the invention. If desired, a small vessel remains behind in order to generate a number of further combustion cycles via the operating principle of the invention, although it is also possible to envisage this taking place wholly autonomously after some time. It is sufficient that enough fuel is present for this purpose.

**[0013]** The support member arranged according to the invention in transverse direction on the pile imparts an increased load-bearing capacity to the pile-driver when this support member is driven onto the underlying ground. This high load-bearing capacity is derived from the support member which under downward load - in addition to the point resistance and shaft friction resistance present for each pile - encounters an additional resistance from the ground being compressed.

**[0014]** According to a preferred embodiment, the flex-

ible member located above the support member comprises a flexible membrane which, together with the support member, encloses the combustion space of variable volume.

**[0015]** Although it is possible to envisage the flexible member located above the support member per se enclosing a combustion space of variable volume, such as a submersible, bag-like body, this combustion space is preferably enclosed by the support member and the flexible member together.

**[0016]** According to a further preferred embodiment, the medium present above the support member is separated from the surrounding area by a separating wall. Because the medium is located in the pile and thereby closed off at least by the wall of the pile from the water present outside the pile, only this medium is displaced as a result of the expansion of the combustion space. Because the displaced medium is isolated from the surrounding area, a shockwave in the surrounding water is prevented. Shockwaves harmful to marine life are thus prevented during the pile-driving operations.

**[0017]** According to a further preferred embodiment, the pile-driver is integrated into the pile, and the separating wall separating the medium present above the support member from the surrounding area is the wall of the pile. Because the pile-driver is integrated into the pile, a plurality of piles can be driven substantially simultaneously, whereby marine life is exposed for a much shorter period of time to noise nuisance resulting from the pile-driving.

**[0018]** According to an alternative preferred embodiment, the pile is received extendably in a post of a framework construction and the support member arranged on the pile is mounted in or on the pile, wherein the separating wall separating the medium present above the support member from the surrounding area is the wall of the pile and/or the wall of the post of the framework construction.

**[0019]** For locations with a water depth of more than 25 metres it is usual to apply special frames, also referred to as space frames. These framework constructions transmit the forces via a number of piles to the seabed in order to minimize the mass/stiffness ratio. A drawback of such frameworks is that each pile has to be driven individually or each pile is anchored separately, which, with the conventional pile-drivers, takes a number of working hours proportional to the number of piles. Arranging the pile extendably in a post of the framework construction (or space frame) as according to the invention enables this framework to be submerged to the seabed, after which the pile can be driven downward from the framework into the seabed. Because a conventional pile-driver is not required, according to the invention the different piles can be driven substantially simultaneously into the ground. In the system according to the invention the number of working hours is not therefore proportional to the number of piles: the driving of three piles takes almost the same amount of time as driving a single pile.

This is particularly advantageous for marine life, which is exposed for a much shorter period of time to noise nuisance resulting from the pile-driving.

**[0020]** The system according to the invention is therefore able to pile-drive preassembled constructions, wherein the foundation is, if desired, already attached to the wind turbine. Such a construction can be shipped in and submerged before the construction is driven into place.

**[0021]** According to yet another preferred embodiment, the medium present above the support member is water. Water is present in abundance particularly in the case of offshore pile-driving, whereby transport of an alternative medium to the location is unnecessary. A further advantage of water is the high heat transfer coefficient thereof, whereby there is rapid discharge and distribution of the heat released during combustion.

**[0022]** According to yet another preferred embodiment, the flexible membrane is manufactured from rubber. Rubber can impart the desired stretchability to the flexible membrane and is surprisingly able to withstand the temperatures occurring during combustion when a medium with sufficiently high heat transfer coefficient, such as water, is utilized as reaction mass.

**[0023]** According to yet another preferred embodiment, the pile-driver further comprises a fuel supply channel for carrying fuel into the combustion space, and a combustion product discharge channel for discharging combustion products after combustion. Because the combustion space can be filled with fuel and emptied of combustion products in a short time, the system is suitable for a series of successive combustions in a relatively short period of time.

**[0024]** According to yet another preferred embodiment, at least a closure is provided which, together with the support member and the separating wall, encloses a substantially gas-tight volume, and wherein a pump is further provided for the purpose of thereby carrying a fluid into and/or out of the substantially gas-tight volume.

**[0025]** The fluid is preferably air and/or water, wherein using the fluid air a pre-pressure can be applied in the substantially gas-tight closed space, and the fluid water provides a reaction mass.

**[0026]** A pile which is driven into the ground encounters a total driving resistance which is the sum of the point resistance and the shaft friction resistance. Depending on parameters such as the soil type, length of the pile and the shape of the pile, both resistances and therefore the total driving resistance vary. Influencing the quantity of water and air present in the substantially gas-tight volume by using the pump makes it possible to optimize the pressure build-up profile in accordance with the driving force desired at that moment. Control means which determine the desired driving force for a specific set of parameters can control the pump accordingly. Tests have shown that, when a pre-pressure is applied, only 5 metres water column can already realize a peak pressure of 10-15 bar. Higher peak pressures can be achieved with

a higher water column.

**[0027]** The further the pile has already been driven into the ground, the more rigid it is. The shaft friction resistance in particular also increases as the underground length increases. However, because the pile becomes increasingly more rigid, an increasingly larger amount of reaction mass in the form of water column can also be supported therein. The increase in the rigidity of the pile allows a higher centre of gravity of the pile, without the stability being adversely affected.

**[0028]** The point resistance and/or the shaft friction resistance can also be reduced by introducing a liquid during driving of the pile, for instance at the head of the pile or along the wall of the pile. An example of such a liquid is grout, a mixture of cement and water. When this grout later cures, a better attachment of the pile to the soil is also achieved, whereby the load-bearing capacity is finally higher than if this pile were to be driven without this liquid.

**[0029]** According to yet another preferred embodiment, a plurality of combustion spaces of variable volume are enclosed between the support member and one or more flexible membranes. The system can be applied more flexibly by using a plurality of combustion spaces. It is thus possible for instance to coordinate successive combustions with each other in optimal manner. It is possible on the one hand to envisage a subsequent combustion space already being filled with fuel while a combustion space which has just been ignited still has to be emptied of the combustion products present therein. The subsequent combustion can on the other hand take place during the descent of the reaction mass displaced upward in a previous combustion such that the pressure build-up is optimized in accordance with the driving resistance to be overcome at that moment.

**[0030]** According to yet another preferred embodiment, at least two ignition mechanisms are provided which are adapted to selectively ignite the fuel in one or more predetermined combustion spaces. Selective ignition of one or more predetermined combustion spaces enables the pile to be exposed to an asymmetric load. This makes it possible to control the pile such that a possible misalignment can be corrected.

**[0031]** According to yet another preferred embodiment, the plurality of combustion spaces are arranged rotation-symmetrically relative to the central longitudinal axis of the pile. Such a disposition provides the option - depending on whether the combustion spaces are ignited simultaneously or selectively - of exerting a symmetrical as well as asymmetrical load on the pile.

**[0032]** According to yet another preferred embodiment, control means are provided which are adapted to inject extra fuel into a combustion space during the combustion of the fuel and/or to vary the moment of ignition. The pressure build-up profile can hereby be optimized in accordance with the driving force desired at that moment. Control means which determine the desired driving force for a specific set of parameters can control injection of

extra fuel accordingly.

**[0033]** According to yet another preferred embodiment, there is provided on both the upper and underside of the support member a flexible membrane which, together with the support member, encloses a combustion space of variable volume. When a support member is arranged in the pile, this can likewise be employed for the purpose of driving the pile out of the ground when the supported structure is dismantled. By also providing the underside as well as the upper side of the support member with a flexible membrane which, together with the support member, encloses a combustion space of variable volume, the pile can be driven out of the ground using the same principle with which it has been driven into the ground. When there is a substantially gas-tight connection of the support member to the inner wall of the pile, this driving out can for instance take place or be supported by means of a pressure build-up in the volume enclosed by the inner wall of the pile, the support member and the seabed.

**[0034]** According to yet another preferred embodiment, an opening is arranged in the wall of the pile under the support member. It is noted that 'under' refers to the orientation during the pile-driving process, i.e. the opening is arranged in the wall part between the support member and the ground into which the pile is driven. Arranging a hole of determined (optionally variable) size under the support member makes it possible to regulate the outflow speed of the liquid present under the support member. The descent speed of the pile as a result of an impact can hereby also be limited. The pile can hereby be placed more easily using a crane since there is a risk in normal pile-driving of cable overload. Cable overload refers to a situation in which the pile overshoots by an unexpectedly great distance such that all the available play is exceeded and a high shock load can be transmitted to the hoisting means of the crane. Such a shock load is undesirable and may cause serious damage to the crane.

**[0035]** According to yet another preferred embodiment, the opening is variable and control means are provided with which the size of the opening can be controlled. The descent speed of the pile can hereby be even better controlled.

**[0036]** According to yet another preferred embodiment, the combustion space is in gas connection with an underpressure space which is adapted to suction combustion products released during combustion out of the combustion space. By means of an underpressure the combustion products released during combustion are suctioned out of the combustion space in a very short time. The combustion products can hereby be removed before the medium displaced in upward direction by the combustion drops back and collides once again with the support member. Because the falling medium does not drop onto a 'gas spring' but actually 'strikes' the support member, the downward force exerted on the support member by this falling medium can be used substantially wholly to drive the pile downward into the ground.

**[0037]** The invention further relates to a method for driving a pile downward into the ground, comprising the steps of:

- combusting a fuel above a support member arranged or arrangeable in transverse direction at or on a pile;
- wherein this fuel is situated in a flexible member which is located above the support member and encloses a combustion space of variable volume, and which expands during combustion;
- displacing a medium located above the support member in upward direction away therefrom through expansion of the combustion space; and
- driving the pile downward into the ground with the downward reaction force exerted on the pile.

**[0038]** According to a preferred embodiment, the method further comprises the steps of:

- carrying fuel into the combustion space of the flexible member through a fuel supply channel;
- combusting the fuel in the flexible member using the ignition mechanism;
- discharging combustion products through a combustion product discharge channel after combustion; and
- repeating these steps in order to drive the pile stepwise into the ground.

**[0039]** According to a preferred embodiment, the method further comprises the step of injecting extra fuel into the combustion space during combustion of the fuel. The pressure build-up profile can hereby be optimized in accordance with the pile-driving force desired at that moment. If desired, control means which determine the desired driving force for a specific set of parameters control the injection of extra fuel accordingly.

**[0040]** According to a preferred embodiment of the method, at least a closure is provided which, together with the support member and a separating wall, encloses a substantially gas-tight volume, and the method comprises the step of carrying a fluid into and/or out of the substantially gas-tight volume using a pump. Influencing the quantity of water and air present in the substantially gas-tight volume using the pump enables the pressure build-up profile to be optimized in accordance with the driving force desired at that moment.

**[0041]** According to a further preferred embodiment, the fluid is air which brings about a pre-pressure.

**[0042]** According to a further preferred embodiment, the fluid is water which provides a reaction mass.

**[0043]** According to a further preferred embodiment, a plurality of combustion spaces of variable volume are enclosed between the flexible membrane and the support member, and the method comprises the step of selectively igniting the fuel in one or more predetermined combustion spaces. The system can be applied more flexibly by using a plurality of combustion spaces.

**[0044]** According to a further preferred embodiment, the pile is arranged extendably in a post of a framework construction, and the method further comprises the steps of:

- placing the framework construction at a desired location; and
- driving the pile stepwise out of the post of the framework construction and into the ground in order to anchor the framework construction relative to the ground.

**[0045]** According to yet another preferred embodiment, the pile is driven to a depth into the ground such that the support member exerts a pressure on the ground enclosed by the pile. In addition to the point resistance and shaft friction resistance present for each pile, the pile encounters an additional resistance in downward direction from the ground being compressed. This increases the load-bearing capacity of this pile.

**[0046]** According to yet another preferred embodiment, the combustion space is in gas connection with an underpressure space and the method comprises the step, almost immediately after a combustion, of suctioning out of the combustion space the combustion products formed therein, so that these combustion products are at least substantially removed from the combustion space before the medium displaced in upward direction by the combustion drops back and collides once again with the support member.

**[0047]** Preferred embodiments of the present invention are further elucidated in the following description with reference to the drawing, in which:

Figure 1 shows a view of an offshore wind turbine on a monopile construction;

Figure 2 shows a schematic view of the operating principle;

Figure 3 is a detailed cross-sectional view of the support member of the device shown in figure 2;

Figure 4 is a schematic view of four successive stages of the pile-driving process of the construction shown in figures 1 and 2;

Figure 5 shows a schematic view of an alternative embodiment of the pile-driver according to the invention;

Figure 6 shows a view of an offshore wind turbine on a space frame construction;

Figure 7 is a detailed cross-sectional view of the device shown in figure 6, wherein the pile is arranged extendably in the space frame;

Figure 8 is a schematic view of four successive stages of the pile-driving process of the construction shown in figures 6 and 7;

Figure 9 is a detailed perspective view of the device shown in figure 7;

Figure 10 is a cut-away perspective view of the device shown in figure 9;

Figure 11 shows a schematic top view of a preferred arrangement of a plurality of combustion spaces; Figure 12 shows a schematic view of four successive stages of the pile-driving process with a further preferred embodiment of a pile-driver according to the invention; and Figure 13 shows a schematic view of four successive stages of the pile-driving process with yet another preferred embodiment of a pile-driver according to the invention.

**[0048]** The offshore wind turbine 26 shown in figure 1 is a so-called monopile construction and comprises a pile 2 which is driven fixedly into the ground 30 below water level 28.

**[0049]** The operating principle of fixedly driving the wind turbine construction 26 of figure 1 is shown schematically in figure 2 using stages A, B and C. Arranged in pile 2 is a support member 4, directly above which is located a flexible member 6.

**[0050]** Flexible member 6 encloses a combustion space 8 which is filled with a fuel. When this fuel combusts, flexible member 6 will expand in a very short time, whereby the medium 32 present above support member 4 and flexible member 6 will be moved in upward direction away from support member 4. Although other media are likewise suitable, use is preferably made of the medium water, which is available in abundance offshore. In stage B water column 32 is displaced in upward direction by the expansion of flexible member 6.

**[0051]** It is noted that the operating principle in figure 2 is shown on enlarged scale. According to Newton's third law the upward displacement of water column 32 is accompanied by an equal and opposite reaction force, which displaces pile 2 in downward direction.

**[0052]** The upward driven water column 32 will then drop back again onto support member 4, where it exerts a further downward force on pile 2. In stage C pile 2 has already been driven over some downward distance into ground 30.

**[0053]** Although it is possible to envisage a fuel being submerged each time onto or close to support member 4 in a flexible member 6 suitable for this purpose, it is particularly advantageous to have flexible member 6 and support member 4 enclose combustion space 8 together.

**[0054]** Obtained by means of a fuel supply channel 12, an oxygen supply channel 13 and a combustion product discharge channel 14 is a device which is suitable for bringing about a series of successive combustions. It will be apparent that the fuel supply channel 12 and the oxygen supply channel 13 can, if desired, be integrated into a single channel supplying a combustible mixture.

**[0055]** The fuel in combustion space 8 can be brought to combustion by means of an ignition mechanism 10, after which flexible member 6 expands and drives pile 2 into the ground in accordance with the operating principle shown in figure 2. An optimal force transmission to pile 2 is guaranteed by embodying support member 4 as a

plate part which supports on the underside on pile 2 via shoring plates 34 (figure 3).

**[0056]** Arranged in the wall of pile 2 under support member 4 is an opening 42 through which overpressure created under support member 4 during pile-driving can escape to the surrounding area. Opening 42 provides a restrictive passage with which the outflow speed of the liquid present under support member 4 to the surrounding area can be regulated. The descent speed of pile 2 as a result of an impact can hereby also be limited, whereby opening 42 reduces the chance of undesired shock load on the crane. The cable overload occurring during normal pile-driving can hereby be prevented.

**[0057]** Figure 3 further shows an optional underpressure space 44 which is in gas connection with combustion space 8 via a valve 36. By opening valve 36 immediately after a combustion the combustion products released during the combustion are suctioned in a very short time out of combustion space 8 to underpressure space 44, in which a lower pressure prevails than in combustion space 8. The combustion products are removed from combustion space 8 before the medium displaced in upward direction by the combustion drops back and once again collides with the support member. The falling medium hereby does not drop onto a 'gas spring' but collides with support member 4. The downward force exerted by this falling medium on support member 4 can hereby be utilized almost completely for the purpose of driving pile 2 downward into the ground.

**[0058]** As a pile 2 is driven deeper into ground 30, pile 2 will obtain more stability and be able to bear more mass. The total pile-driving resistance encountered by pile 2 is the sum of the point resistance and the shaft friction resistance. The shaft friction resistance increases as a greater part of pile 2 is driven into ground 30. Since this situation is also associated with a pile 2 which has already obtained some stability, water column 32 can be increased - see the transition from stage A to stage B and the transition from stage B to stage C in figure 4.

**[0059]** Water column 32 is separated from the surrounding area by a separating wall 5. In the embodiment in which the pile-driver is integrated into pile 2, inner wall 3 of pile 2 forms this separating wall 5 (figures 2-5).

**[0060]** As shown in stages C and D, support member 4 is driven some distance into the underlying ground enclosed by pile 2. Because support member 4 makes contact with this ground, pile 2 has an increased load-bearing capacity.

**[0061]** Provided according to a further preferred embodiment is a closure 16 which, together with support member 4 and the inner wall of pile 2, encloses a volume sealed in substantially gas-tight manner (figure 5). With a pump 20 air and/or water can be introduced into this sealed volume, whereby the pressure build-up profile resulting from the combustion of fuel in combustion space 8 of flexible member 6 can be optimized for driving pile 2 downward into ground 30.

**[0062]** As shown in figure 5, water column 32 is higher

in stage B than in stage A. The desired pre-pressure resulting from the quantity of air present in the sealed volume can also be adjusted so as to optimize the desired pressure build-up.

**[0063]** From a greater water depth of about 25 metres it is usual to apply a framework construction, or space frame. Such a framework construction 24 has posts 22, wherein in the shown embodiment a pile 2 is arranged extendably in such a post 22.

**[0064]** In accordance with the same operating principle as already elucidated above, pile 2 can be moved downward relative to post 22, whereby pile 2 is driven into ground 30 and framework construction 24 is anchored to the seabed.

**[0065]** As shown in figure 7, a seal 38 is preferably situated between the inner wall of post 22 and the outer wall of support member 4 so that the pressure build-up above support member 4 can be prevented from flowing partially away between the outer wall of pile 2 and the inner wall of post 22.

**[0066]** Water column 32 is once again separated from the surrounding area by a separating wall 5, which is formed in the embodiment shown in figure 7 by inner wall 23 of post 2 in which pile 2 is slidably received.

**[0067]** It is noted that in an embodiment (not shown) in which support member 4 is not arranged at the end of pile 2, inner wall 3 of pile 2 can form separating wall 5 together with inner wall 23.

**[0068]** The schematic view of figure 8 shows how a pile 2 is driven out of post 22 into ground 30 in different stages A-D. Water column 32 can once again be raised as pile 2 moves deeper into ground 30 (see stages B and C).

**[0069]** Since pile 2 is extendable relative to post 22, according to a preferred embodiment supply channels 12, 13 for the fuel and the oxygen are supplied centrally from above, from where they debouch into an annular combustion space 8. Combustion space 8 is enclosed by a flexible member 6 and support member 4. After ignition mechanism 10 has ignited the fuel present in combustion space 8, the combustion products can escape from combustion space 8 via the valve 36 in the space under support member 4.

**[0070]** An opening (not shown) in the inner wall under support member 4 makes it possible for these combustion products to then escape from pile 2 to the surrounding area. This opening (not shown) in the wall is also necessary so as to prevent a pressure build-up under support member 4 during downward driving of pile 2.

**[0071]** The schematic top view of figure 11 shows a possible configuration of combustion spaces, which are preferably arranged rotation-symmetrically relative to the central longitudinal axis 40 of pile 2. Successive pairwise or selective ignition of fuel in one or more of the shown combustion spaces 8 enables optimizing of the pressure build-up profile and, if desired, correction of pile 2 for a possible small misalignment. It is thus possible for instance to envisage the fuel in combustion space 8a being

brought to combustion and, during the descent of the water column 32 which has thereby been displaced upward, a pair-wise ignition of combustion spaces, for instance 8b and 8e, taking place simultaneously. Because combustion spaces 8b and 8e are located rotation-symmetrically relative to the central longitudinal axis 40 of pile 2, a symmetrical downward force will be exerted on pile 2. When however it is the wish to correct pile 2 for some misalignment, it is possible for instance for the fuel present in a single combustion space, such as for instance 8c, to be brought to combustion.

**[0072]** The pressure build-up profile can likewise be optimized by injecting extra fuel into a combustion space as desired during the combustion.

**[0073]** According to the further preferred embodiments shown in figures 12 and 13, pile-driver 1 is placed on top of a pile 2 in order to thereby drive pile 2 downward into ground 30. The pile-driver comprises for this purpose a support member 4 which can be arranged on a pile 2.

**[0074]** The embodiment shown in figure 12 is a pile-driver 1 in telescopic form, wherein tube segments 50, 52 and 54 together form separating wall 5. Tube segment 50 of pile-driver 1 is connected with a support arm 48 to a vessel (not shown).

**[0075]** When pile 2 is driven further into the ground 30, third segment 54 slides out of first segment 50 and second segment 52 (stage B).

**[0076]** When pile 2 is driven still further into ground 30, second segment 52 also slides out of first segment 50 (stage C).

**[0077]** Because segments 52, 54 of pile-driver 1 slide out of segment 50 in telescopic manner, the length of pile-driver 1 increases. Extra water column 32 (not shown) can hereby be arranged above support member 4. This water column 32 (not shown) is separated from the surrounding area here by separating wall 5 formed by the wall of segments 50, 52, 54.

**[0078]** In stage D pile 2 has reached the desired depth in the ground and pile-driver 1 is in a retracted position.

**[0079]** The embodiment shown in figure 13 operates almost identically to the embodiment of figure 12, with the difference that the pile-driver consists of a single segment 50 which slides through an encasing guide part 46. This encasing guide part 46 is connected with a support arm 48 to a vessel (not shown).

**[0080]** It is particularly noted that the skilled person can combine technical measures of the different embodiments, such as for instance the embodiments shown in figures 12 and 13 provided with a closing plate part 16 as described with reference to figure 5. The described rights are defined by the following claims, within the scope of which many modifications can be envisaged.

## 55 Claims

1. Pile-driver, comprising:

- a support member (4) arranged or arrangeable in transverse direction at or on a pile;  
 - at least one flexible member (6) situated above and close to the support member and enclosing a combustion space (8) of variable volume;  
 - an ignition mechanism (10) adapted to ignite a fuel present in the combustion space; and  
 - wherein the combustion space (8) is adapted to expand during combustion such that a medium located above the support member (4) is displaced at least in upward direction away therefrom and a downward force is thereby exerted on the pile (2) via the support member.
2. Pile-driver as claimed in claim 1, wherein the flexible member (6) located above the support member (4) comprises a flexible membrane which, together with the support member, encloses the combustion space of variable volume.
3. Pile-driver as claimed in claim 2, wherein the medium present above the support member (4) is separated from the surrounding area by a separating wall.
4. Pile-driver as claimed in claim 3, wherein:
- the pile-driver is integrated into the pile (2), and wherein the separating wall separating the medium present above the support member from the surrounding area is the wall of the pile (2); or
  - wherein the pile is received extendably in a post of a framework construction and the support member (4) arranged on the pile is mounted in or on the pile, and wherein the separating wall separating the medium present above the support member from the surrounding area is the wall of the pile and/or the wall of the post of the framework construction.
5. Pile-driver as claimed in any of the claims 2-4, further comprising:
- a fuel supply channel (12) for carrying fuel into the combustion space (8); and
  - a combustion product discharge channel for discharging combustion products after combustion.
6. Pile-driver as claimed in any of the foregoing claims, wherein:
- at least a closure (16) is provided which, together with the support member and the separating wall (5), encloses a substantially gas-tight volume; and
  - a pump (20) is provided for the purpose of thereby carrying a fluid into and/or out of the substantially gas-tight volume.
7. Pile-driver as claimed in any of the claims 2-6, wherein:
- a plurality of combustion spaces (8) of variable volume are enclosed between the support member (4) and one or more flexible membranes;
  - wherein preferably at least two ignition mechanisms are provided which are adapted to selectively ignite the fuel in one or more predetermined combustion spaces (8); and
  - wherein preferably the plurality of combustion spaces are arranged rotation-symmetrically relative to the central longitudinal axis of the pile (2).
8. Pile-driver as claimed in any of the claims 2-7, wherein:
- control means are provided which are adapted to inject extra fuel into a combustion space (8) during the combustion of the fuel and/or to vary the moment of ignition; and/or
  - wherein there is provided on both the upper and underside of the support member (4) a flexible membrane which, together with the support member, encloses a combustion space (8) of variable volume.
9. Pile-driver as claimed in any of the foregoing claims, wherein:
- an opening is arranged in the wall of the pile (2) under the support member (4); and
  - wherein preferably the opening is variable and control means are provided with which the size of the opening can be controlled.
10. Pile-driver as claimed in any of the foregoing claims, wherein the combustion space (8) is in gas connection with an underpressure space which is adapted to suction combustion products released during combustion out of the combustion space (8).
11. Method for driving a pile downward into the ground, comprising the steps of:
- combusting a fuel above a support member (4) arranged or arrangeable in transverse direction at or on a pile (2);
  - wherein this fuel is situated in a flexible member which is located above the support member (4) and encloses a combustion space (8) of variable volume, and which expands during combustion;
  - displacing a medium located above the support member in upward direction away therefrom through expansion of the combustion space (8); and
  - driving the pile (2) downward into the ground

with the downward reaction force exerted on the pile.

12. Method as claimed in claim 11, further comprising the steps of:

- carrying fuel into the combustion space of the flexible member through a fuel supply channel (12);
- combusting the fuel in the flexible member using the ignition mechanism (10);
- discharging combustion products through a combustion product discharge channel after combustion; and
- repeating these steps in order to drive the pile stepwise into the ground.

13. Method as claimed in claim 11 or 12, wherein:

- at least a closure (16) is provided which, together with a separating wall, encloses a substantially gas-tight volume, and comprising the step of carrying a fluid into and/or out of the substantially gas-tight volume using a pump (20);
- wherein preferably the fluid is air and brings about a pre-pressure; and
- wherein preferably the fluid is water and provides a reaction mass.

14. Method as claimed in any of the claims 11-13, wherein a plurality of combustion spaces (8) of variable volume are enclosed between the flexible membrane and the support member (4), and comprising the step of selectively igniting the fuel in one or more predetermined combustion spaces (8).

15. Method as claimed in any of the claims 11-14, wherein:

- the pile (2) is arranged extendably in a post of a framework construction, and comprising the steps of:

- placing the framework construction at a desired location; and
- driving the pile stepwise out of the post of the framework construction and into the ground in order to anchor the framework construction relative to the ground;

- wherein preferably the pile is driven to a depth into the ground such that the support member (4) exerts a pressure on the ground enclosed by the pile; and

- wherein preferably the combustion space (8) is in gas connection with an underpressure space and the method comprises the step, almost immediately after a combustion, of suction-

ing out of the combustion space the combustion products formed therein, so that these combustion products are at least substantially removed from the combustion space before the medium displaced in upward direction by the combustion drops back and collides once again with the support member (4).

## 10 Patentansprüche

1. Pfahlramme, enthaltend:

- ein in Querrichtung an oder auf einem Pfahl angeordnetes oder anordenbares Unte stützelement (4);
- zumindest ein oberhalb des und nahe dem Unterstützelement befindliches und einen Verbrennungsraum (8) mit veränderbarem Volumen umschließendes flexibles Element (6);
- einen zum Zünden eines in dem Verbrennungsraum vorhandenen Brennstoffs ausgebildeten Zündmechanismus (10); und
- wobei der Verbrennungsraum (8) ausgebildet ist, sich während der Verbrennung auszudehnen, so dass ein Medium, das sich oberhalb des Unterstützelements (4) befindet, zumindest in Aufwärtsrichtung von diesem weg verschoben wird und dabei eine abwärtsgerichtete Kraft über das Unterstützelement auf den Pfahl (2) ausgeübt wird.

2. Pfahlramme gemäß Anspruch 1, wobei das oberhalb des Unterstützelements (4) befindliche flexible Element (6) eine flexible Membran, welche gemeinsam mit dem Unterstützelement den Verbrennungsraum mit veränderbarem Volumen umschließt, enthält.

3. Pfahlramme gemäß Anspruch 2, wobei das oberhalb des Unterstützelements (4) befindliche Medium vom Umgebungsbereich durch eine Trennwand getrennt ist.

4. Pfahlramme gemäß Anspruch 3, wobei:

- die Pfahlramme in den Pfahl (2) integriert ist, und wobei die das oberhalb des Unterstützelements befindliche Medium vom Umgebungsbereich trennende Trennwand die Wand des Pfahls (2) ist; oder

- wobei der Pfahl verlängerbar in einem Pfosten eines Gerüstbaus aufgenommen ist und das auf dem Pfahl angeordnete Unterstützelement (4) in oder auf dem Pfahl angebracht ist, und wobei die das oberhalb des Unterstützelements befindliche Medium vom Umgebungsbereich trennende Trennwand die Wand

- des Pfahls und/oder die Wand des Pfostens des Gerüstaufbaus ist.
5. Pfahlramme gemäß einem der Ansprüche 2 bis 4, weiter enthaltend: 5
- einen Brennstoffversorgungs kanal (12) zum Leiten von Brennstoff in den Verbrennungsraum (8); und
  - einen Verbrennungsproduktauslasskanal zum Auslassen von Verbrennungsprodukten nach der Verbrennung. 10
6. Pfahlramme gemäß einem der vorstehenden Ansprüche, wobei: 15
- zumindest ein Verschluss (16) vorgesehen ist, der gemeinsam mit dem Unterstützungselement und der Trennwand (5) einen im Wesentlichen gasdichten Raum umschließt; und 20
  - eine Pumpe (20) zu dem Zweck, um damit ein Fluid in den und/oder aus dem im Wesentlichen gasdichten Raum zu leiten, vorgesehen ist.
7. Pfahlramme gemäß einem der Ansprüche 2 bis 6, wobei: 25
- mehrere Verbrennungsräume (8) mit veränderbarem Volumen zwischen dem Unterstützungselement (4) und einer oder mehreren flexiblen Membranen eingeschlossen sind; 30
  - wobei bevorzugt zumindest zwei Zündmechanismen, welche ausgebildet sind, den Brennstoff in einem oder mehreren vorbestimmten Verbrennungsräumen (8) gezielt zu zünden, vorgesehen sind; und 35
  - wobei die mehreren Verbrennungsräume bevorzugt rotationssymmetrisch bezüglich der zentralen Längsachse des Pfahls (2) angeordnet sind. 40
8. Pfahlramme gemäß einem der Ansprüche 2 bis 7, wobei: 45
- Regulierungsmittel, welche ausgebildet sind, während der Verbrennung des Brennstoffs zusätzlicher Brennstoff in einen Verbrennungsraum (8) einzuspritzen und/oder den Zeitpunkt der Zündung zu verändern, vorgesehen sind; und/oder 50
  - wobei sowohl auf der Ober- als auch auf der Unterseite des Unterstützungselements (4) eine flexible Membran, welche gemeinsam mit dem Unterstützungselement einen Verbrennungsraum (8) mit veränderbarem Volumen umschließt, vorgesehen ist. 55
9. Pfahlramme gemäß einem der vorstehenden Ansprüche, wobei: 60
- in der Wand des Pfahls (2) unter dem Unterstützungselement (4) eine Öffnung angeordnet ist; und
  - wobei die Öffnung bevorzugt veränderbar ist und Regulierungsmittel, mit denen die Größe der Öffnung reguliert werden kann, vorgesehen sind. 65
10. Pfahlramme gemäß einem der vorstehenden Ansprüche, wobei der Verbrennungsraum (8) in gasdurchlässiger Verbindung mit einem Unterdruckraum, der ausgebildet ist, während der Verbrennung aus dem Verbrennungsraum (8) heraus abgegebene Verbrennungsprodukte abzusaugen, steht.
11. Verfahren zum Abwärts-Rammen eines Pfahls in den Grund, enthaltend die Schritte: 70
- Verbrennen eines Brennstoffs oberhalb eines in Querrichtung an oder auf einem Pfahl (2) angeordneten oder anordenbaren Unterstützungselements (4);
  - wobei sich dieser Brennstoff in einem flexiblen Element, welches sich oberhalb des Unterstützungselements (4) befindet und einen Verbrennungsraum (8) mit veränderbarem Volumen umschließt und welches sich während der Verbrennung ausdehnt, befindet;
  - Verschieben eines Mediums, das sich oberhalb des Unterstützungselements befindet, in Aufwärtsrichtung von diesem weg durch Ausdehnung des Verbrennungsraums (8); und
  - Abwärts-Rammen des Pfahls (2) in den Grund mittels der abwärtsgerichteten auf den Pfahl ausgeübten Gegenkraft.
12. Verfahren gemäß Anspruch 11, weiter enthaltend die Schritte: 75
- Leiten von Brennstoff in den Verbrennungsraum des flexiblen Elements durch einen Brennstoffversorgungs kanal (12);
  - Verbrennen des Brennstoffs im flexiblen Element unter Verwendung des Zündmechanismus (10);
  - Auslassen von Verbrennungsprodukten durch einen Verbrennungsproduktauslasskanal nach der Verbrennung; und
  - Wiederholen dieser Schritte, um den Pfahl schrittweise in den Grund zu rammen.
13. Verfahren gemäß einem der Ansprüche 11 oder 12, wobei: 80
- zumindest ein Verschluss (16), welcher zusammen mit einer Trennwand einen im Wesent-

lichen gasdichten Raum umschließt, vorgesehen ist, und enthaltend den Schritt des Leitens eines Fluids in den und/oder aus dem im Wesentlichen gasdichten Raum unter Verwendung einer Pumpe (20);

- wobei das Fluid bevorzugt Luft ist und einen Vordruck verursacht; und

- wobei das Fluid bevorzugt Wasser ist und eine Gegenkraftmasse bereitstellt.

14. Verfahren gemäß einem der Ansprüche 11 bis 13, wobei mehrere Verbrennungsräume (8) mit veränderbarem Volumen zwischen der flexiblen Membran und dem Unterstützungselement (4) eingeschlossen sind, und enthaltend den Schritt des gezielten Zündens des Brennstoffs in einem oder mehreren vorbestimmten Verbrennungsräumen (8).

15. Verfahren gemäß einem der Ansprüche 11 bis 14, wobei:

- der Pfahl (2) verlängerbar in einem Pfosten eines Gerüstaufbaus angeordnet ist, und enthaltend die Schritte:

- Platzieren des Gerüstaufbaus an einer gewünschten Stelle; und

- schrittweises Rammen des Pfahls aus dem Pfosten des Gerüstaufbaus heraus und in den Grund hinein, um die Gerüstkonstruktion relativ zum Grund zu verankern;

- wobei der Pfahl bevorzugt bis zu einer Tiefe in den Grund gerammt wird, so dass das Unterstützungselement (4) einen Druck auf den vom Pfahl umschlossenen Grund ausübt; und

- wobei der Verbrennungsraum (8) bevorzugt in einer gasdurchlässigen Verbindung mit einem Unterdruckraum steht und das Verfahren den Schritt, beinahe unmittelbar nach der Verbrennung aus dem Verbrennungsraum die darin geformten Verbrennungsprodukte abzusaugen, enthält, so dass diese Verbrennungsprodukte zumindest im Wesentlichen aus dem Verbrennungsraum entfernt sind, bevor das durch die Verbrennung in Aufwärtsrichtung verschobene Medium zurück fällt und erneut mit dem Unterstützungselement (4) zusammenstößt.

## Revendications

1. Sonnette de battage, qui comprend :

- un élément de support (4) placé ou qui peut être placé dans une direction transversale au niveau de ou sur une colonne ;

- au moins un élément flexible (6) situé au-dessus et près de l'élément de support et qui renferme un espace de combustion (8) à volume

variable ;

- un mécanisme d'allumage (10) adapté pour allumer un combustible présent dans l'espace de combustion ; et

- dans laquelle l'espace de combustion (8) est adapté pour se dilater pendant la combustion de sorte qu'un milieu qui se trouve au-dessus de l'élément de support (4) soit déplacé au moins vers le haut à l'écart de celui-ci, et qu'une force descendante soit ainsi exercée sur la colonne (2) par le biais de l'élément de support.

2. Sonnette de battage selon la revendication 1, dans laquelle l'élément flexible (6) situé au-dessus de l'élément de support (4) comprend une membrane flexible qui, avec l'élément de support, renferme l'espace de combustion à volume variable.

3. Sonnette de battage selon la revendication 2, dans laquelle le milieu présent au-dessus de l'élément de support (4) est séparé de la zone située autour par une paroi de séparation.

4. Sonnette de battage selon la revendication 3, dans laquelle :

- la sonnette de battage est intégrée à la colonne (2), et dans laquelle la paroi de séparation qui sépare le milieu présent au-dessus de l'élément de support de la zone située autour est la paroi de la colonne (2) ; ou

- dans laquelle la colonne est reçue de manière extensible dans un poteau d'une armature et l'élément de support (4) placé sur la colonne est monté dans ou sur la colonne, et dans laquelle la paroi de séparation qui sépare le milieu présent au-dessus de l'élément de support de la zone située autour est la paroi de la colonne et/ou la paroi de l'armature.

5. Sonnette de battage selon l'une quelconque des revendications 2 à 4, qui comprend en outre :

- un canal d'alimentation en combustible (12) destiné à acheminer un combustible vers l'espace de combustion (8) ; et

- un canal d'évacuation de produit de combustion destiné à évacuer les produits de combustion après la combustion.

6. Sonnette de battage selon l'une quelconque des revendications précédentes, dans laquelle :

- au moins une fermeture (16) est prévue et, avec l'élément de support et la paroi de séparation (5), renferme un volume sensiblement étanche au gaz ; et

- une pompe (20) est prévue afin d'acheminer

- un fluide vers et/ou depuis le volume sensiblement étanche au gaz.
7. Sonnette de battage selon l'une quelconque des revendications 2 à 6, dans laquelle :
- une pluralité d'espaces de combustion (8) à volume variable est enfermée entre l'élément de support (4) et une ou plusieurs membrane(s) flexible(s) ;
  - dans laquelle, de préférence, au moins deux mécanismes d'allumage sont prévus, et sont adaptés pour allumer sélectivement le combustible dans un ou plusieurs espace(s) de combustion prédéterminé(s) (8) ; et
  - dans laquelle, de préférence, la pluralité d'espaces de combustion est disposée de manière symétrique, par rotation, par rapport à l'axe longitudinal central de la colonne (2).
8. Sonnette de battage selon l'une quelconque des revendications 2 à 7, dans laquelle :
- un moyen de commande est prévu, et est adapté pour injecter davantage de combustible dans un espace de combustion (8) pendant la combustion du combustible et/ou pour faire varier le moment d'allumage ; et/ou
  - dans laquelle une membrane flexible est prévue sur la face supérieure et la sous-face de l'élément de support (4), et, avec l'élément de support, renferme un espace de combustion (8) à volume variable.
9. Sonnette de battage selon l'une quelconque des revendications précédentes, dans laquelle :
- une ouverture est prévue dans la paroi de la colonne (2) sous l'élément de support (4) ; et
  - dans laquelle, de préférence, l'ouverture est variable et un moyen de commande est prévu afin de contrôler la taille de l'ouverture.
10. Sonnette de battage selon l'une quelconque des revendications précédentes, dans laquelle l'espace de combustion (8) est en liaison gazeuse avec un espace en sous-pression qui est adapté pour aspirer les produits de combustion dégagés pendant la combustion dans l'espace de combustion (8).
11. Procédé d'enfoncement d'une colonne dans le sol, qui comprend les étapes qui consistent à :
- faire brûler un combustible au-dessus d'un élément de support (4) placé ou qui peut être placé dans une direction transversale au niveau de ou sur une colonne (2) ;
  - dans lequel ce combustible est situé dans un élément flexible qui se trouve au-dessus de l'élément de support (4) et renferme un espace de combustion (8) à volume variable, et qui se dilate pendant la combustion ;
  - déplacer un milieu situé au-dessus de l'élément de support, vers le haut, à l'écart de celui-ci, par la dilatation de l'espace de combustion (8) ; et
  - enfoncer la colonne (2) dans le sol avec la force de réaction descendante exercée sur la colonne.
12. Procédé selon la revendication 11, qui comprend en outre les étapes qui consistent à :
- acheminer un combustible vers l'espace de combustion de l'élément flexible par le biais d'un canal d'alimentation en combustible (12) ;
  - brûler le combustible dans l'élément flexible à l'aide du mécanisme d'allumage (10) ;
  - évacuer les produits de combustion par le biais d'un canal d'évacuation des produits de combustion après la combustion ; et
  - répéter ces étapes afin d'enfoncer progressivement la colonne dans le sol.
13. Procédé selon la revendication 11 ou 12, dans lequel :
- au moins une fermeture (16) est prévue et, avec une paroi de séparation, renferme un volume sensiblement étanche au gaz, et qui comprend l'étape d'acheminement d'un fluide vers et/ou depuis le volume sensiblement étanche au gaz à l'aide d'une pompe (20) ;
  - dans lequel, de préférence, le fluide est de l'air et provoque une pré-pression ; et
  - dans lequel, de préférence, le fluide est de l'eau et assure une masse de réaction.
14. Procédé selon l'une quelconque des revendications 11 à 13, dans lequel une pluralité d'espaces de combustion (8) à volume variable est enfermée entre la membrane flexible et l'élément de support (4), et qui comprend l'étape qui consiste à allumer sélectivement le combustible dans un ou plusieurs espace(s) de combustion prédéterminé(s) (8).
15. Procédé selon l'une quelconque des revendications 11 à 14, dans lequel :
- la colonne (2) est placée de manière extensible dans un poteau d'une armature, et qui comprend les étapes qui consistent à :
    - placer l'armature à un emplacement souhaité ; et

- sortir progressivement la colonne du poteau de l'armature et l'enfoncer dans le sol afin d'ancrer l'armature par rapport au sol ;
- dans lequel, de préférence, la colonne est enfoncée à une profondeur dans le sol de sorte que l'élément de support (4) exerce une pression sur le sol enfermé par la colonne ; et
- dans lequel, de préférence, l'espace de combustion (8) est en liaison gazeuse avec un espace en sous-pression, et le procédé comprend l'étape, quasiment juste après une combustion, qui consiste à aspirer dans l'espace de combustion les produits de combustion formés à l'intérieur, de sorte que ces produits de combustion soient au moins sensiblement retirés de l'espace de combustion avant que le milieu déplacé vers le haut par la combustion retombe et entre à nouveau en collision avec l'élément de support (4).

5

10

15

20

25

30

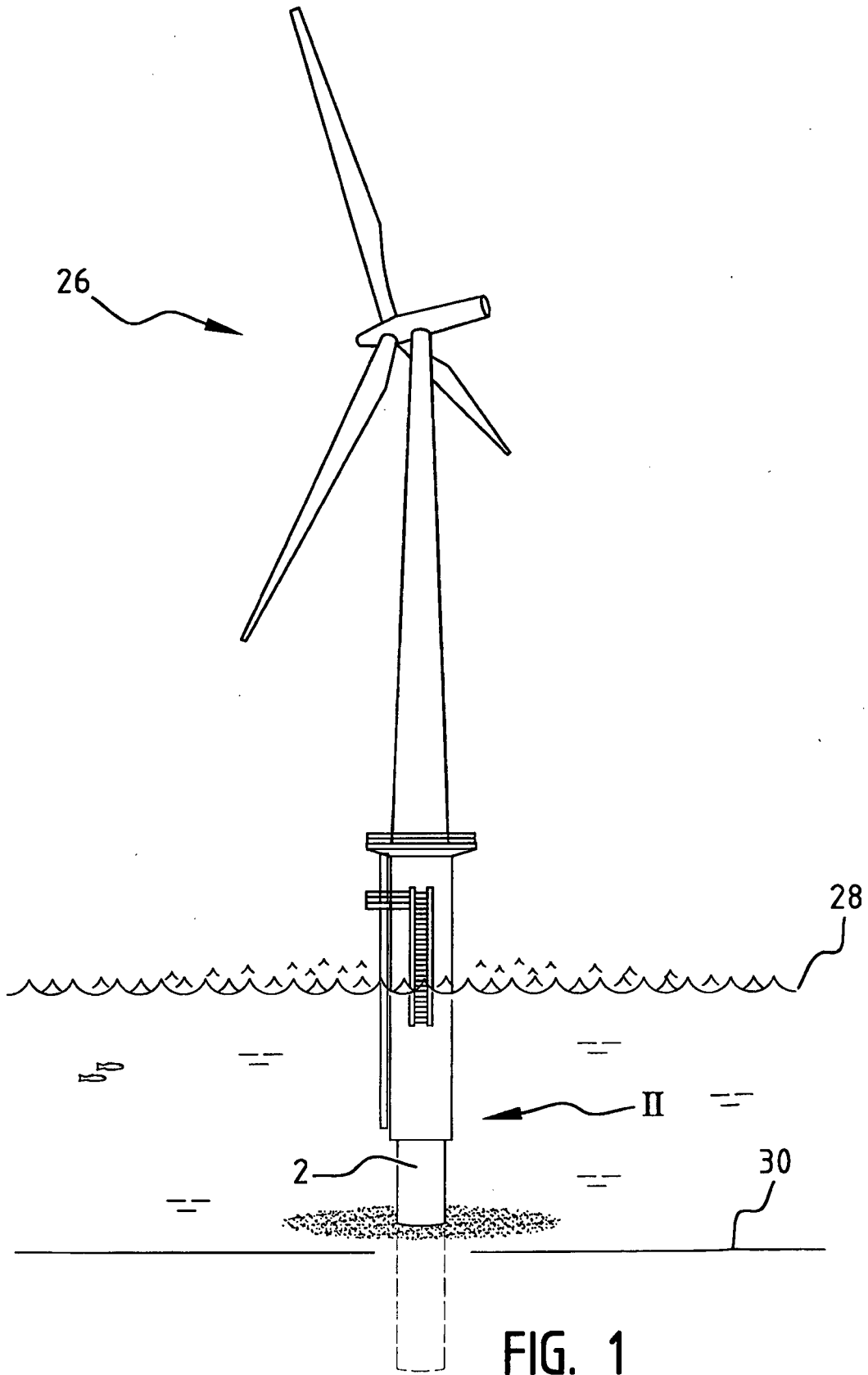
35

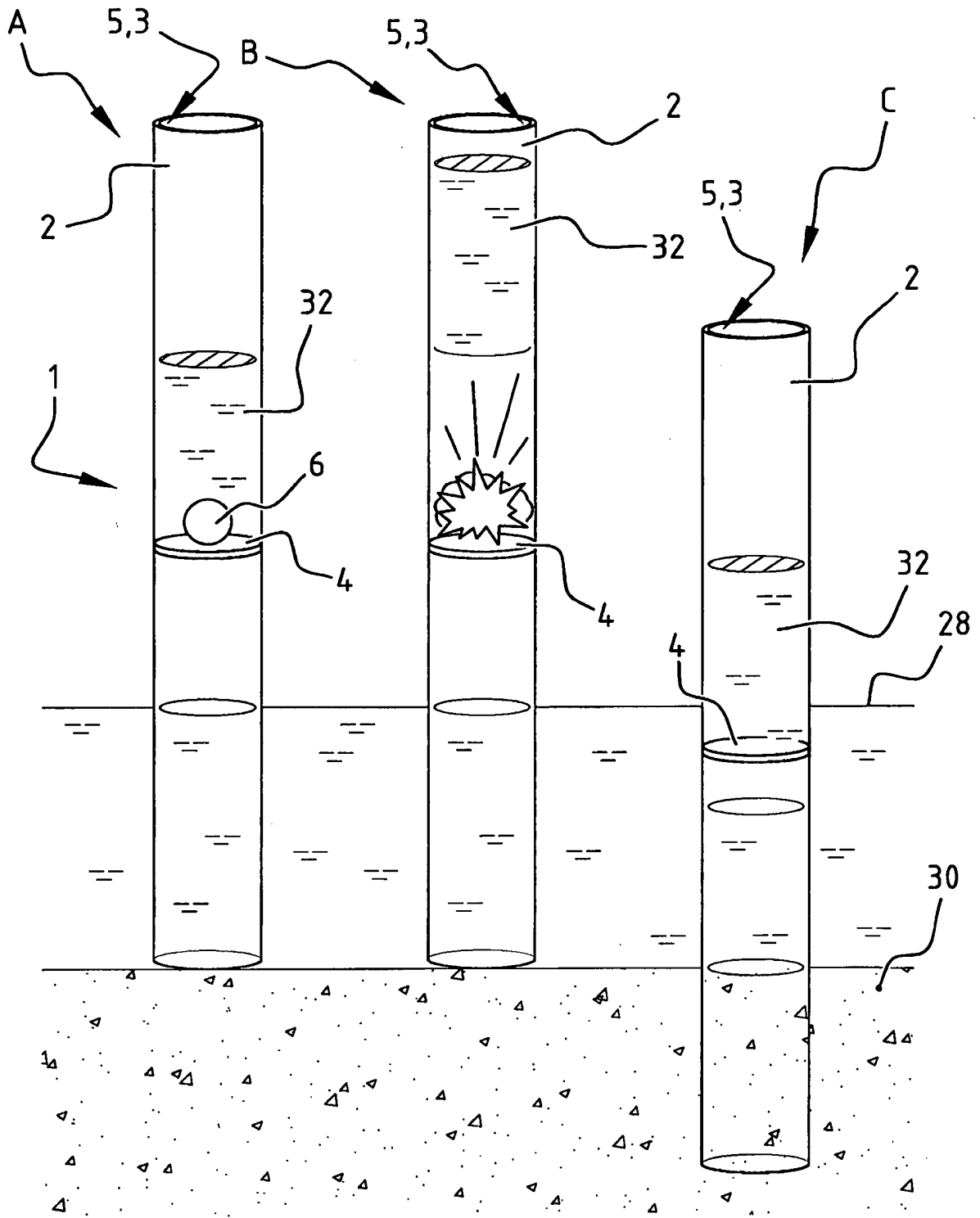
40

45

50

55





**FIG. 2**

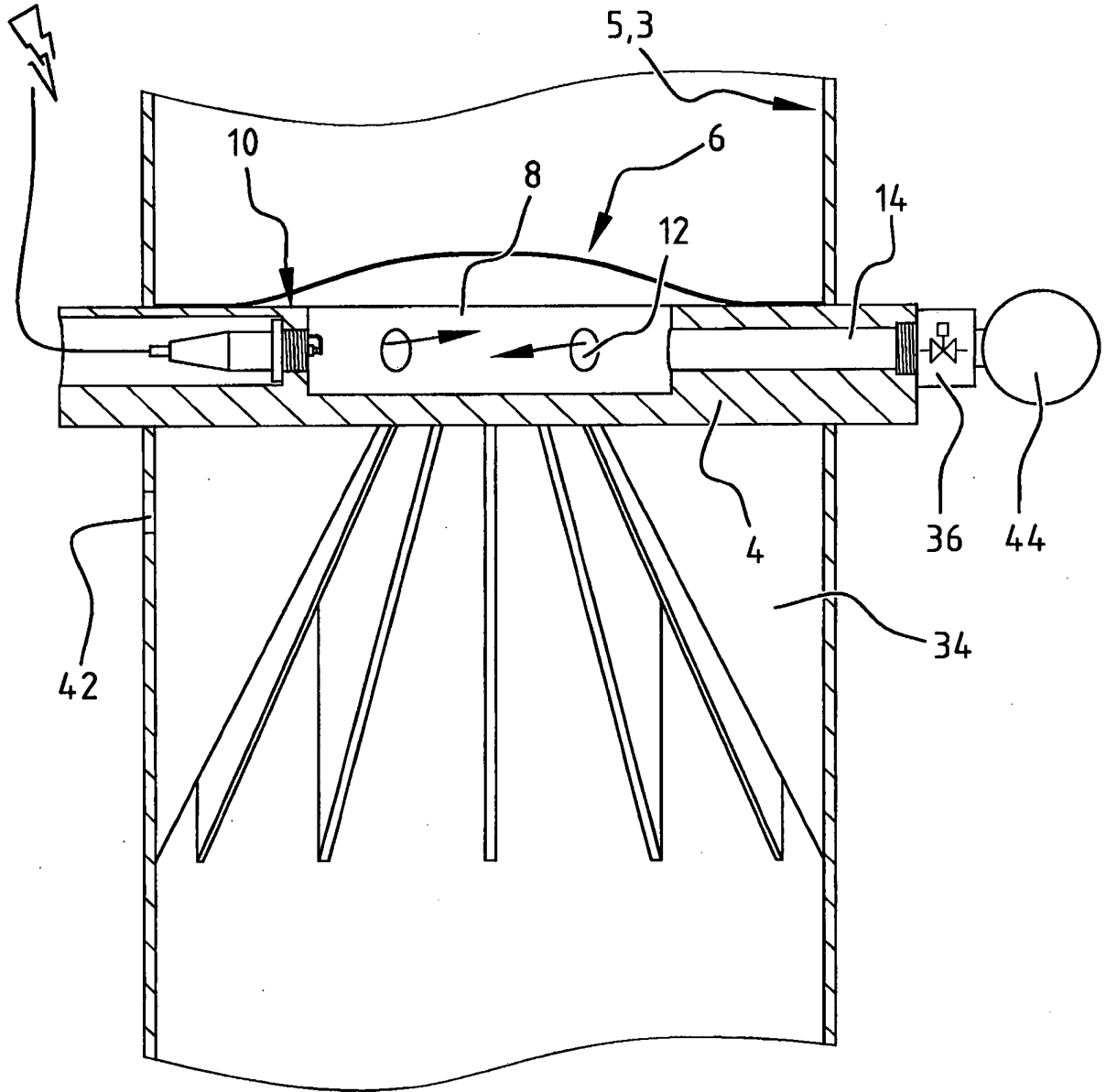
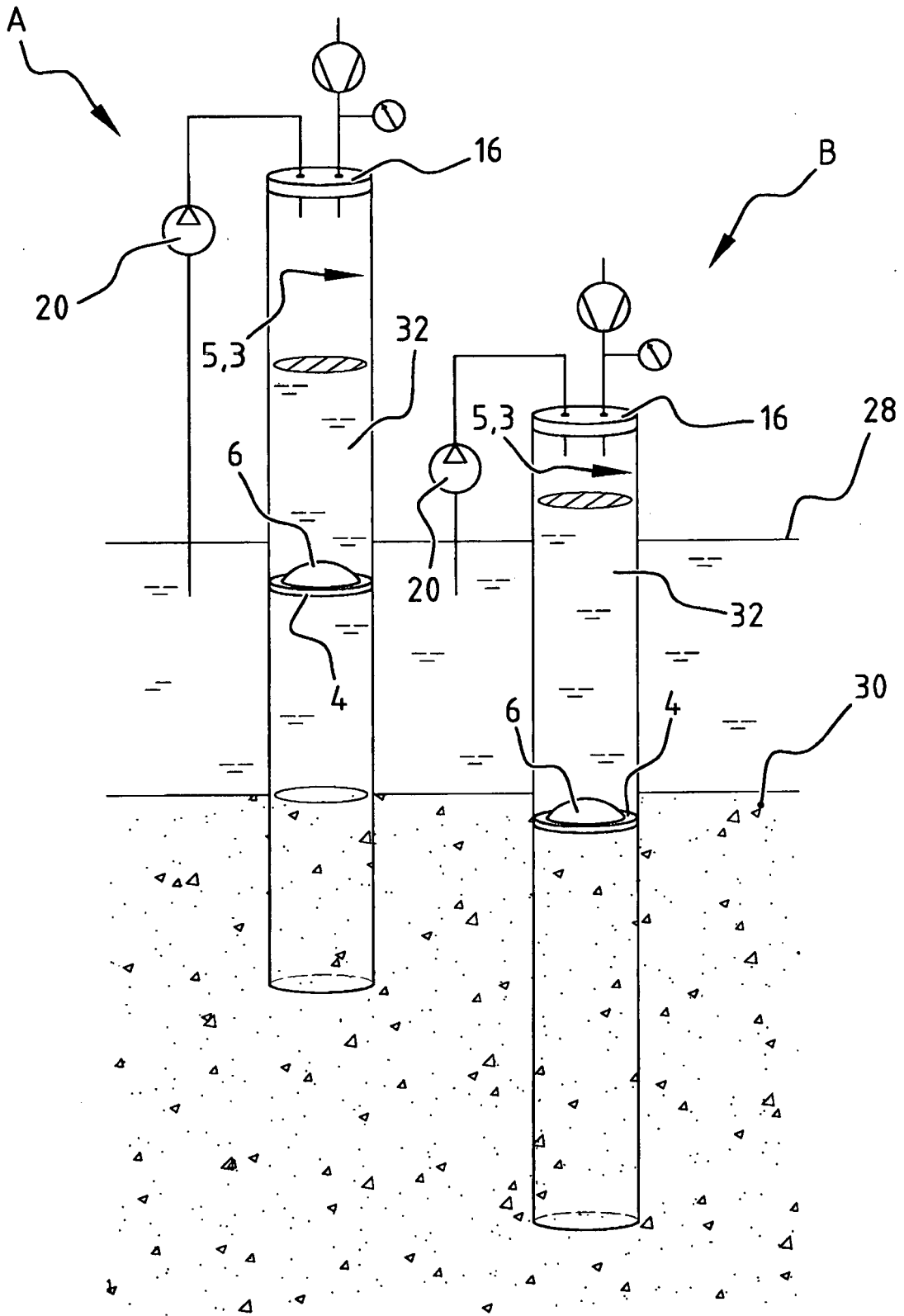


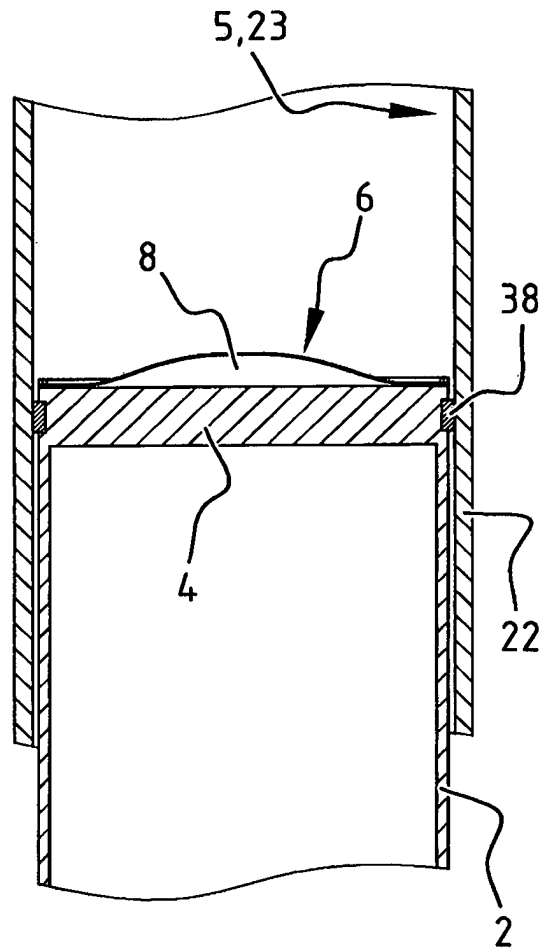
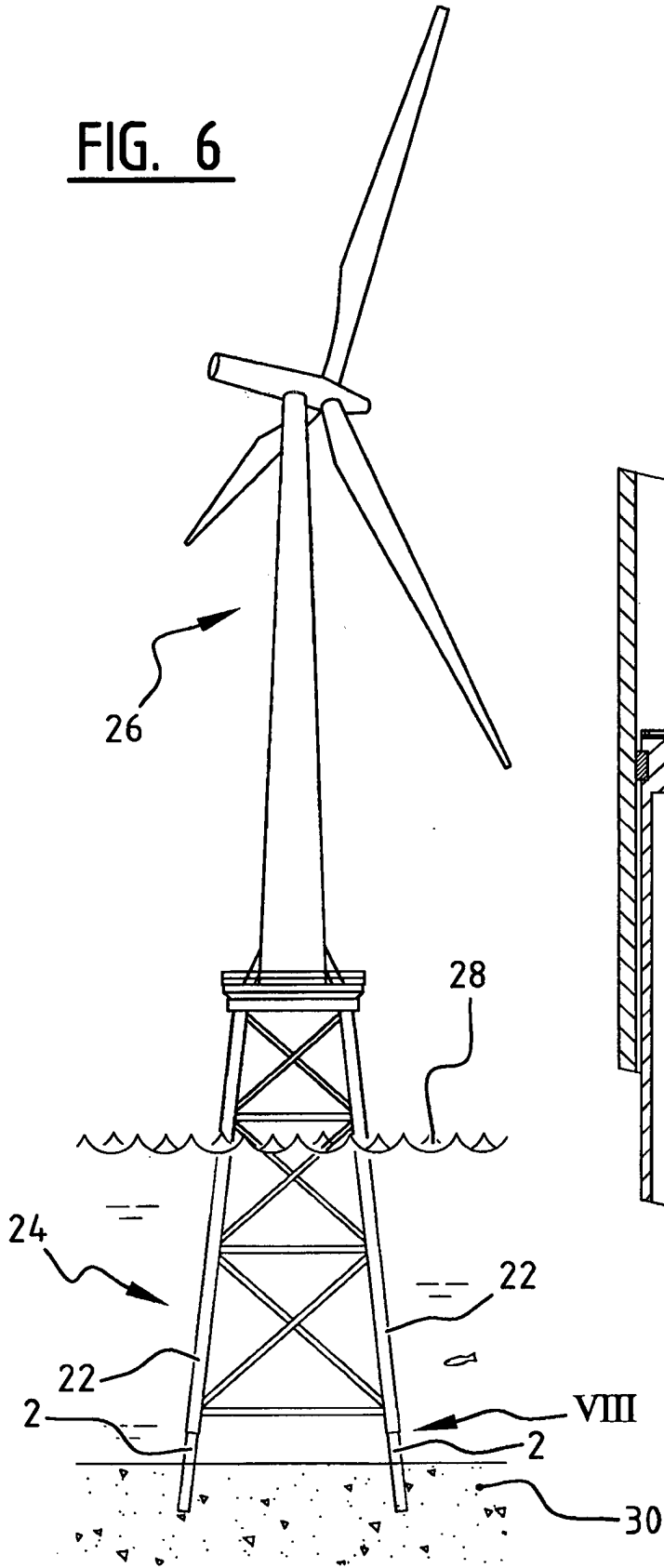
FIG. 3



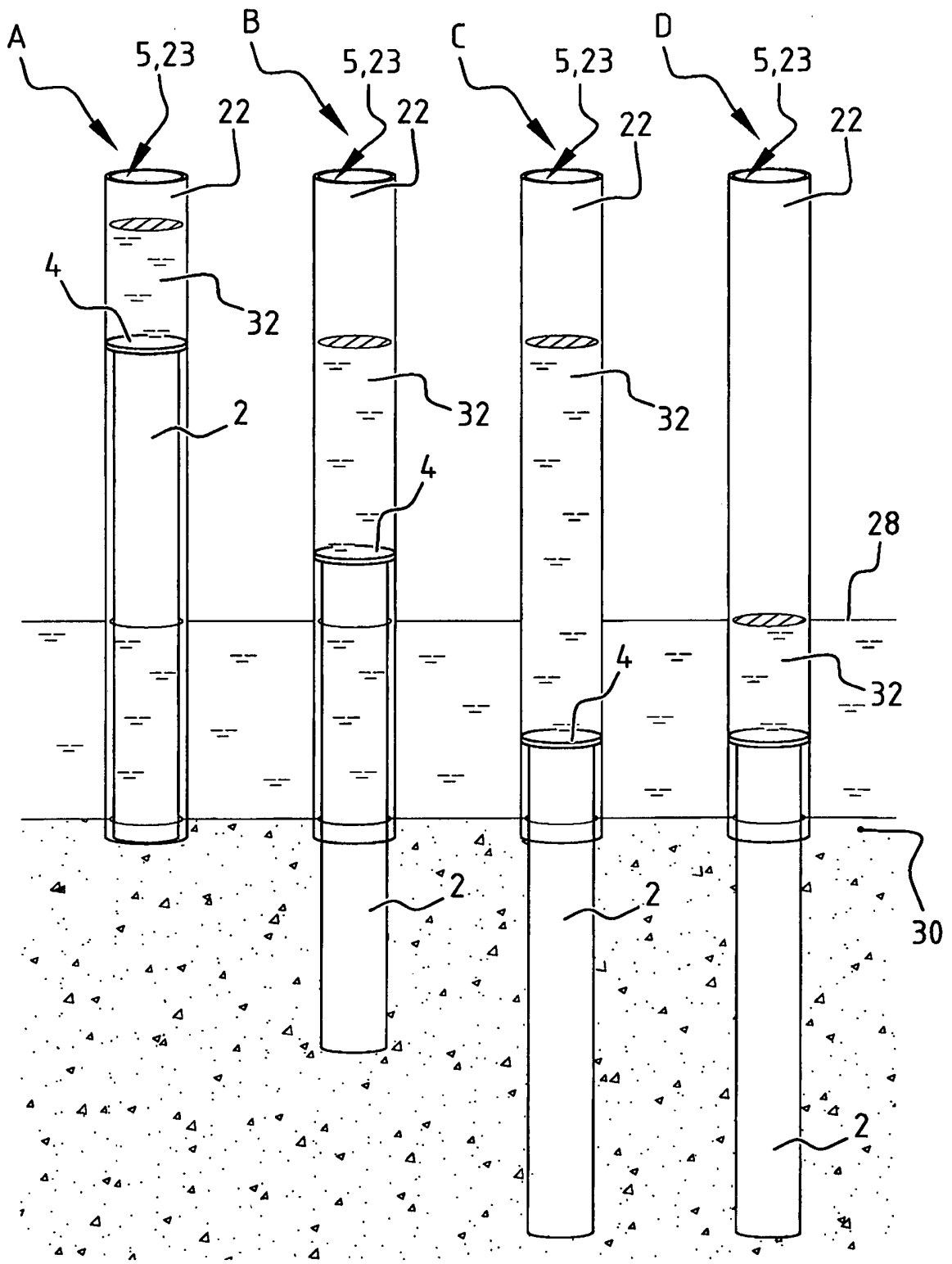


**FIG. 5**

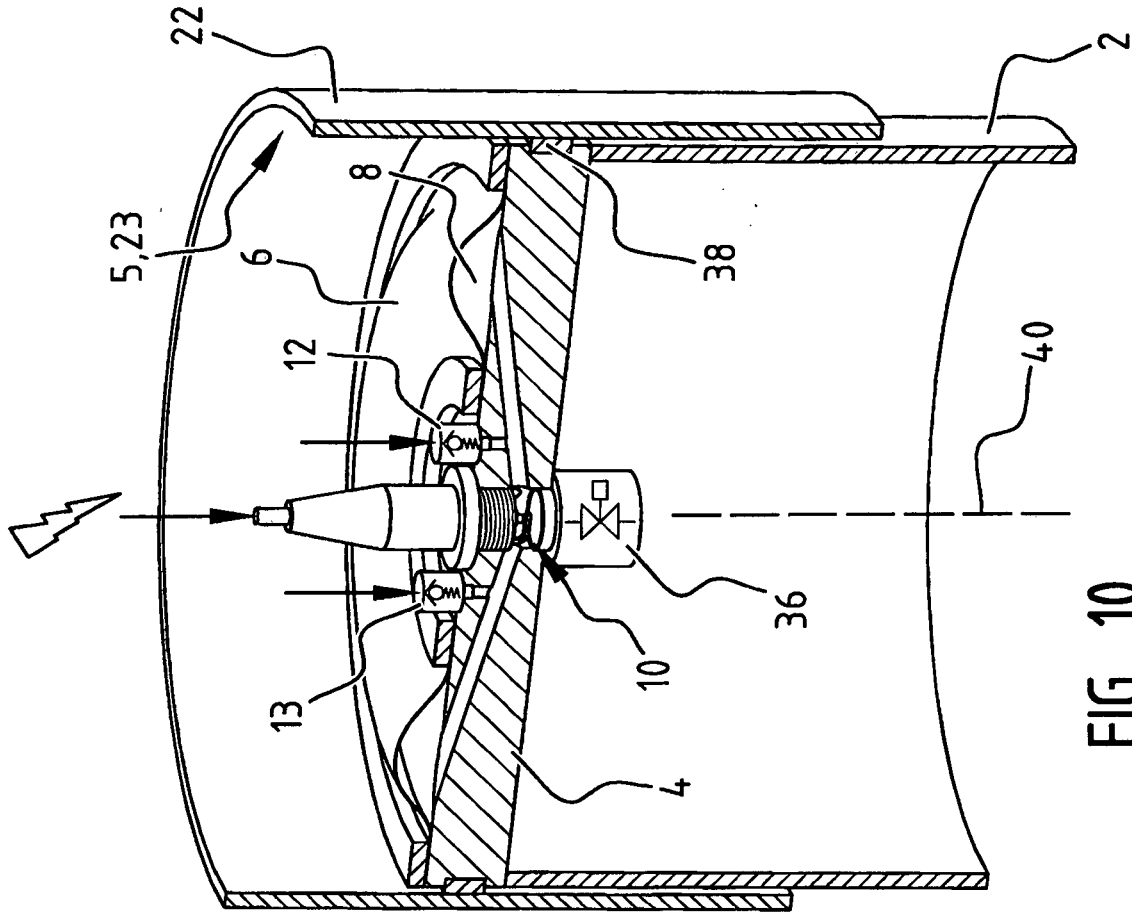
**FIG. 6**



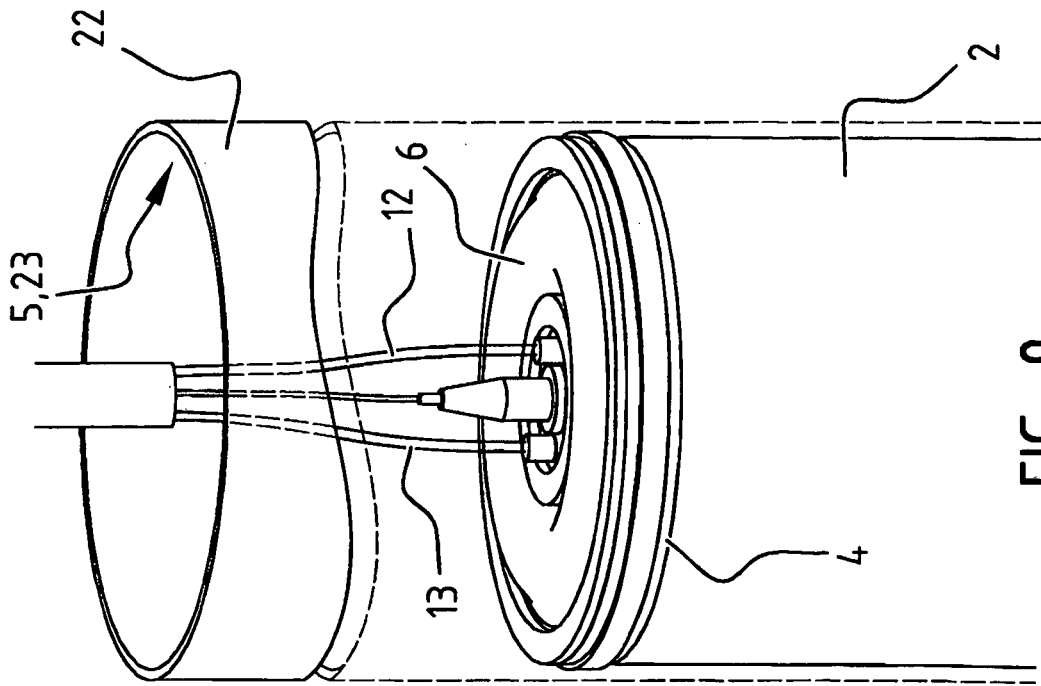
**FIG. 7**



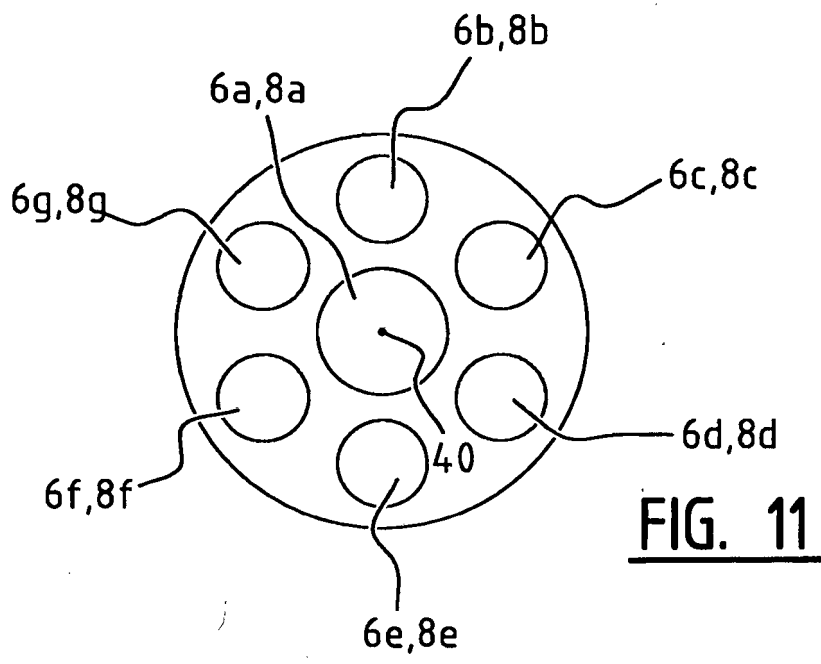
**FIG. 8**

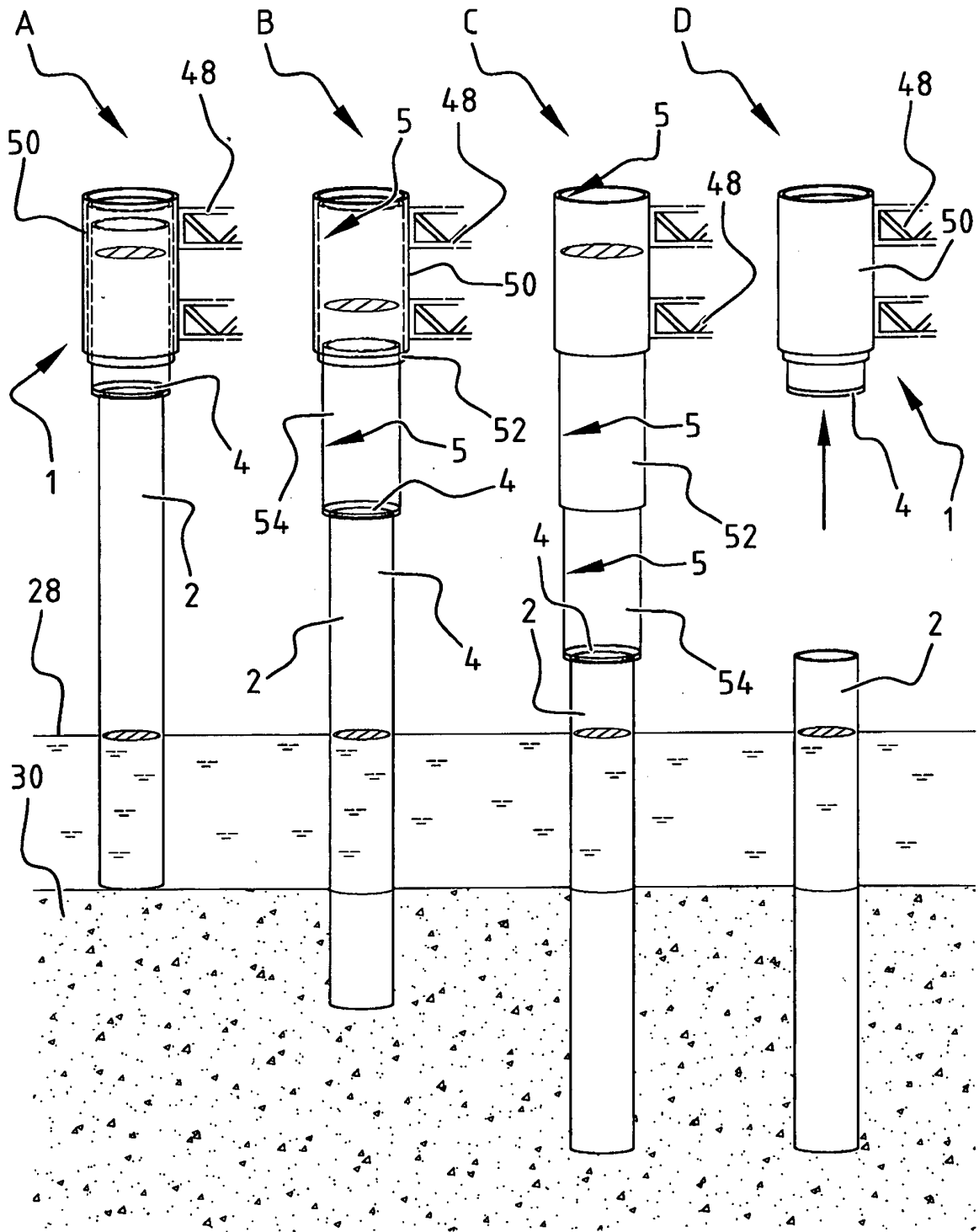


**FIG. 10**

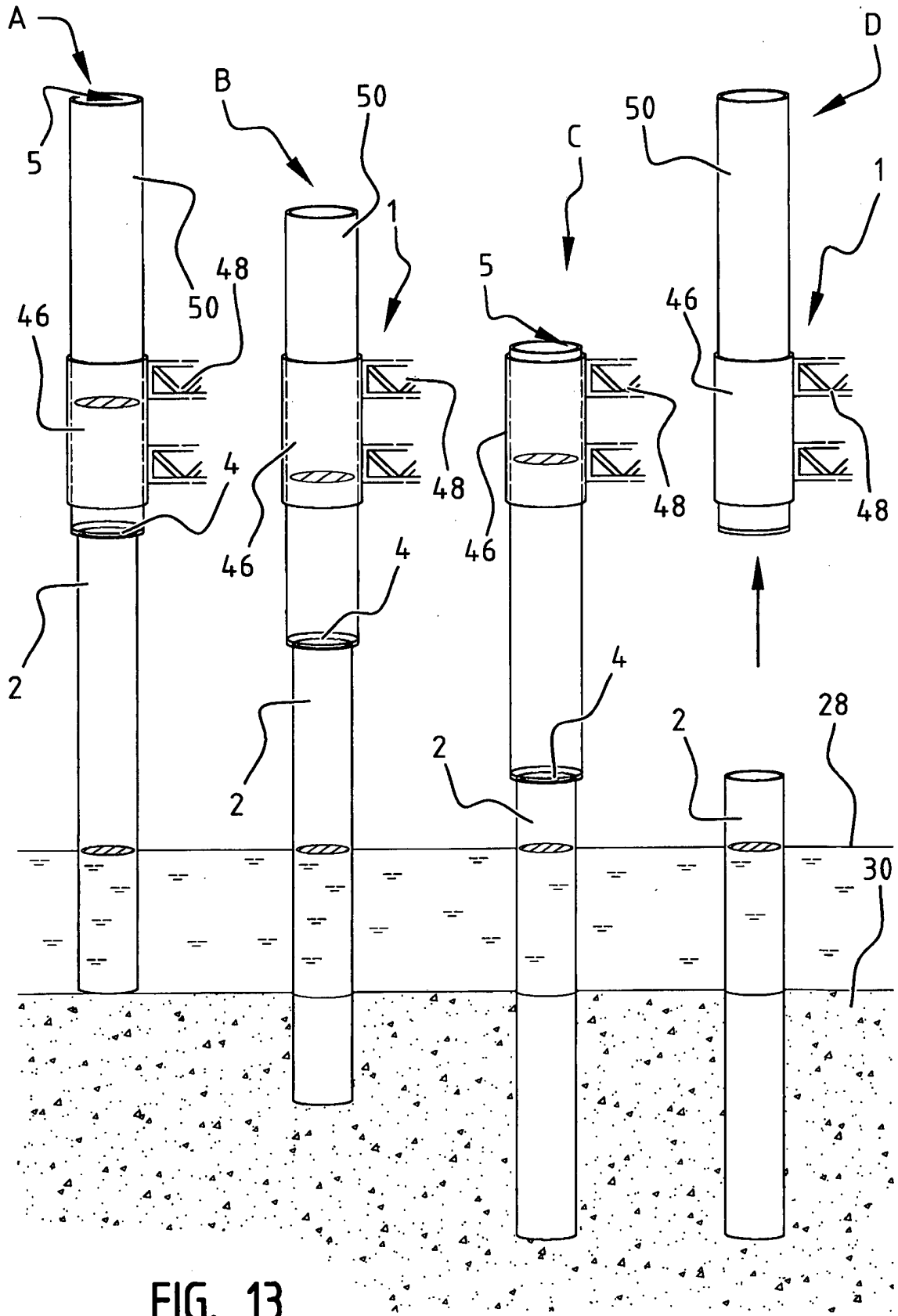


**FIG. 9**





**FIG. 12**



**REFERENCES CITED IN THE DESCRIPTION**

*This list of references cited by the applicant is for the reader's convenience only. It does not form part of the European patent document. Even though great care has been taken in compiling the references, errors or omissions cannot be excluded and the EPO disclaims all liability in this regard.*

**Patent documents cited in the description**

- US 1746848 A1 [0001]