



(12) **EUROPEAN PATENT APPLICATION**

(43) Date of publication:
31.12.2014 Bulletin 2015/01

(51) Int Cl.:
A47L 9/32^(2006.01)

(21) Application number: **13184516.6**

(22) Date of filing: **16.09.2013**

(84) Designated Contracting States:
AL AT BE BG CH CY CZ DE DK EE ES FI FR GB GR HR HU IE IS IT LI LT LU LV MC MK MT NL NO PL PT RO RS SE SI SK SM TR
Designated Extension States:
BA ME

(71) Applicant: **Bukang Sems Co., Ltd. Incheon (KR)**

(72) Inventor: **Lee, Sungjin Incheon (KR)**

(74) Representative: **Gulde & Partner Patent- und Rechtsanwaltskanzlei mbB Wallstraße 58/59 10179 Berlin (DE)**

(30) Priority: **24.06.2013 KR 20130005088 U**

(54) **Vacuum cleaner**

(57) A vacuum cleaner (100), in which a handle (150) installed at a main body (110) is rotated and is folded, and the direction and the length of the handle (150) are adjusted according to a user's physical condition or a cleaning environment so that the vacuum cleaner (100) can be conveniently used, the vacuum cleaner (100) including: a main body (110); a first support part (130) and a second support part (140) that are installed at an outer

side of the main body (110) and are spaced apart from each other by a predetermined distance; and a handle (150) combined between the first support part (130) and the second support part (140) part, wherein one end of the handle (150) is pivotably installed at the first support part (130), and the other end of the handle (150) is detachably installed at the second support part (140).

FIG. 1

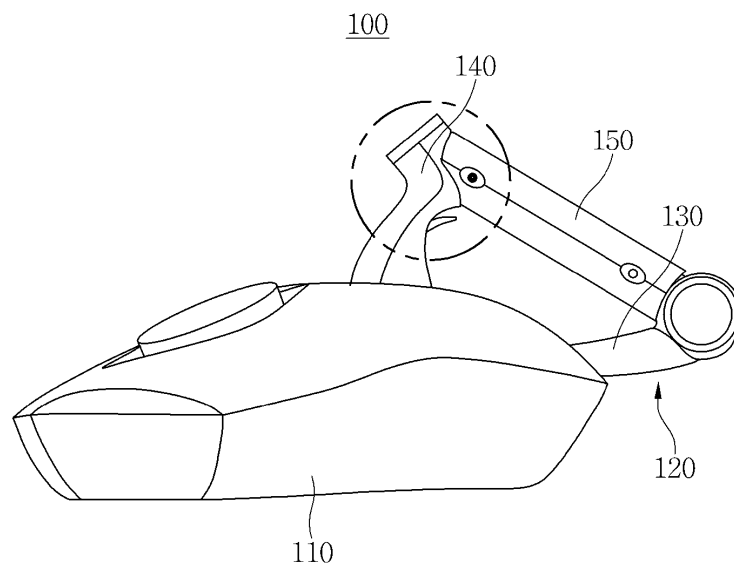

Description

BACKGROUND

1. Field of the Invention

[0001] The present invention relates to a vacuum cleaner, and more particularly, to a handy type vacuum cleaner, in which a handle installed at a main body is rotated and is folded, and the direction and the length of the handle are adjusted according to a user's physical condition or a cleaning environment so that the handle can be conveniently grasped and the vacuum cleaner can be conveniently used according to the cleaning environment.

2. Discussion of Related Art

[0002] Vacuum cleaners are cleaning devices in which a suction force is generated by driving a fan embedded in a main body, air containing foreign substances such as dust and the like is absorbed by the suction force and is dust-collected and clean air that is filtered by an embedded filter is discharged again to the outside.

[0003] These vacuum cleaners are classified into a canister type vacuum cleaner, an upright type vacuum cleaner, and a handy type vacuum cleaner according to their shapes.

[0004] Among them, in the handy type vacuum cleaner, a handle is installed at an outer side of a main body so that a user can easily grasp the handle with his or her hand, and the handle generally includes a rod that is grasped by a user's hand and a support part that fixes one end of the rod to the main body.

[0005] In this way, the handy type vacuum cleaner according to the related art in which the handle is fixed to the support part of the main body, is disclosed in Korean Utility-model Registration No. 20-0447957.

[0006] Also, a handy type vacuum cleaner including a handle that is combined with a main body and is rotated according to the related art is disclosed in Korean Patent Registration No. 10-0389289.

[0007] However, when the handle is fixed to the support part of the main body or is only rotated as mentioned above, the direction and the length of the handle considering a user's physical condition or a cleaning environment cannot be adjusted.

[0008] Thus, in the handy type vacuum cleaner according to the related art, the user must extremely twist a body and a wrist during the usage of the handy type vacuum cleaner. Thus, user fatigue increases when the handy type vacuum cleaner is used for a long time.

[0009] Also, since the length of the handy type vacuum cleaner according to the related art is fixed, a cleaning range in a state in which the user grasps the handle is small and thus it is very inconvenient to clean the house from cellar to rafter.

SUMMARY OF THE INVENTION

[0010] The present invention is directed to a handy type vacuum cleaner that is capable of solving a problem that the direction and the length of a handle provided at a main body cannot be adjusted according to a user's physical condition or a cleaning environment, which causes inconveniences of usage.

[0011] According to an aspect of the present invention, there is provided a vacuum cleaner including: a main body; a first support part and a second support part that are installed at an outer side of the main body and are spaced apart from each other by a predetermined distance; and a handle combined between the first support part and the second support part, wherein one end of the handle is pivotably installed at the first support part, and the other end of the handle is detachably installed at the second support part.

[0012] The handle may include: an inner rod having one end that is pivotably installed at the first support part; and an outer rod that slides along an outer circumferential surface of a lengthwise direction of the inner rod.

[0013] A guide hole may be formed in an outer surface of one side of the inner rod of the handle and may extend in a lengthwise direction of the inner rod of the handle, and a guide protrusion that moves along the guide hole may be provided at the outer rod.

[0014] A fixing protrusion may be installed at the other end of the inner rod and may come into an inner side of the inner rod as an external force is applied to one side of the fixing protrusion, and the fixing protrusion may return to its original state as the external force is removed from the fixing protrusion.

[0015] On the other hand, an inner groove may be formed in the other end of the inner rod of the handle, and an auxiliary protrusion may be formed at an inner side of the other end of the outer rod.

[0016] In addition, a guide protrusion that moves along the guide hole of the inner rod may be formed at an inner side of the outer rod, and a plurality of length adjustment holes in which the fixing protrusions of the inner rod are inserted, may be formed in one side of the outer rod.

[0017] Therefore, as the fixing protrusion of the inner rod is inserted in the plurality of length adjustment holes formed in one side of the outer rod while sliding along the lengthwise direction of the inner rod, the length of the handle may be subdivided at multiple stages and may be adjusted.

[0018] The second support part may include a stopper having a top end on which a hanging part is formed, a prop part that supports one side of the stopper, and a detachment unit configured of a button that is hinge-coupled to the stopper.

BRIEF DESCRIPTION OF THE DRAWINGS

[0019] The above and other objects, features and advantages of the present invention will become more ap-

parent to those of ordinary skill in the art by describing in detail exemplary embodiments thereof with reference to the accompanying drawings, in which:

FIG. 1 is a view illustrating a state in which a handle of a vacuum cleaner according to the present invention is folded;

FIG. 2 is a view for describing the relationship in which the handle of the vacuum cleaner according to the present invention is unfolded;

FIGS. 3A and 3B are views for describing the relationship in which the handle of the vacuum cleaner according to the present invention is locked or unlocked; and

FIGS. 4A and 4B are views for describing adjustment of the length of the handle of the vacuum cleaner according to the present invention.

DETAILED DESCRIPTION OF EXEMPLARY EMBODIMENTS

[0020] Exemplary embodiments of the present invention will be described in detail below with reference to the accompanying drawings. While the present invention is shown and described in connection with exemplary embodiments thereof, it will be apparent to those skilled in the art that various modifications can be made without departing from the spirit and scope of the invention.

[0021] As illustrated in FIG. 1, a vacuum cleaner 100 according to the present invention includes a main body 110, a first support part 130, a second support part 140, and a handle 150.

[0022] The main body 110 includes an upper housing (of which reference numeral is not indicated) and a lower housing (of which reference numeral is not indicated) so as to divide the main body 110 in a vertical direction.

[0023] An air inlet (not shown) for absorbing air is installed on a bottom of the main body 110, i.e., on a bottom of the lower housing, and a plurality of adsorption prevention paths (not shown) are formed at the front of the air inlet along a lengthwise direction of the main body 110 from a front end of the main body 110.

[0024] Here, a plurality of ribs (not shown) for reinforcement are installed on the bottom of the main body 110, and the plurality of adsorption prevention paths are formed between the plurality of ribs provided on the bottom of the main body 110.

[0025] A fan (not shown) that generates a suction force of air and a filter unit (not shown) that filters foreign substances in the air are respectively installed in the main body 110.

[0026] The fan and the filter unit are the same as those of a general vacuum cleaner and thus, detailed descriptions thereof will be omitted.

[0027] A handle assembly according to the present invention has a structure in which the length of a handle 150 extends and contracts while the handle 150 is pivoted. The handle assembly 120 includes a first support part

130, a second support part 140, and the handle 150.

[0028] One end of the first support part 130 is installed at the rear of the main body 110, and a groove 131 in which one end of the handle 150 is inserted, is formed in the other end of the first support part 130.

[0029] When a hinge 132 is inserted into the groove 131 so as to penetrate the groove 131 and to be orthogonal to the handle 150 in a state in which one end of the handle 150 is inserted in the groove 131, the handle 150 and the groove 131 are fastened to each other.

[0030] Thus, the handle 150 fastened to the groove 131 is pivoted toward the front or rear of the main body 110 based on the hinge 132.

[0031] One end of the second support part 140 is fixed to a top surface of the main body 110, and a mounting groove 141 on which the other end of the handle 150 is mounted, is formed in the other end of the second support part 140.

[0032] A detachment unit (of which reference numeral is not indicated) that locks or unlocks the handle 150 mounted on the mounting groove 141, is installed at the second support part 140.

[0033] The detachment unit includes a stopper 142, a hinge 143, a prop part 145, and a button 144.

[0034] The stopper 142 is disposed in the second support part 140, one end of the stopper 142 is pivotably installed by the hinge 143, and a hanging part 142a having a hook shape is installed at the other end of the stopper 142.

[0035] The hanging part 142a is exposed to the outside of the mounting groove 141 of the second support part 140 and is inserted in a hanging groove 155a provided in an outer rod 155 of the handle 150 that closely contacts the mounting groove 141 so that the handle 150 can be locked.

[0036] The button 144 is exposed to the outside of the second support part 140, is connected to one end of the stopper 142, and unlocks the hanging part 142a combined with the hanging groove 155a.

[0037] The detachment unit according to the present invention has been described to lock or unlock the handle 150 using the stopper 142 and the button 144. However, aspects of the present invention are not limited thereto, and any detachment unit that may lock or unlock the handle 150 using the second support part 140 may be used.

[0038] The prop part 145 supports the rear of one end of the stopper 142 and prevents one end of the stopper 142 from being pushed toward the rear of the main body 110 when a user manipulates the button 144.

[0039] The handle 150 includes an inner rod 151 and the outer rod 155.

[0040] One end of the inner rod 151 is fastened to the groove 131 of the first support part 130, and a guide hole 152 is formed to penetrate the inner rod 151 in a lengthwise direction of the inner rod 151.

[0041] When a guide protrusion 156 of the outer rod 155 that will be described below is inserted in the guide hole 152, the guide protrusion 156 is caught in one end

of the guide hole 152 when the user pulls the outer rod 155 combined with an outer side of the inner rod 151. Thus, pulling of the outer rod 155 on the inner rod 151 is limited.

[0042] A fixing protrusion 153 is installed at the other end of the inner rod 151 and comes into an inner side of the inner rod 151 as an external force is applied to one side of the fixing protrusion 153, and the fixing protrusion 153 returns to its original state as the external force is removed from the fixing protrusion 153.

[0043] When the fixing protrusion 153 is inserted into any one of a first length adjustment hole 158 and a second length adjustment hole 159 of the outer rod 155 that will be described below, the outer rod 155 is fixed onto the inner rod 151.

[0044] An inner groove 154 is further provided in the other end of the inner rod 151.

[0045] An auxiliary protrusion 157 of the outer rod 155 that will be described below is inserted into the inner groove 154 of the inner rod 151, movement of the outer rod 155 can be minimized in a state in which the outer rod 155 is combined with the inner rod 151.

[0046] Also, the outer rod 155 of the handle 150 extends in the lengthwise direction of the inner rod 151, and the guide protrusion 156 is installed at an inner surface of one side of the outer rod 155.

[0047] Thus, the guide protrusion 156 is caught in any one end of the guide hole 152 of the inner rod 151 so that pulling of the outer rod 155 on the inner rod 151 is limited.

[0048] Also, the first length adjustment hole 158 and the second length adjustment hole 159 are formed in one side of the outer rod 155.

[0049] The fixing protrusion 153 of the inner rod 151 is inserted into any one of the first length adjustment hole 158 and the second length adjustment hole 159 so that the outer rod 155 can be fixed onto the inner rod 151.

[0050] In the present invention, two of the first length adjustment hole 158 and the second length adjustment hole 159 have been described. However, the number of length adjustment holes is not limited thereto, and when the length of the handle 150 can be further subdivided, more length adjustment holes may be formed.

[0051] On the other hand, the auxiliary protrusion 157 is further formed at an inner side of the other end of the outer rod 155. When the auxiliary protrusion 157 is inserted into the inner groove 154 of the inner rod 151, movement of the outer rod 155 can be minimized in a state in which the outer rod 155 is combined with the inner rod 151.

[0052] The usage of the vacuum cleaner 100 having the above configuration according to the present invention will now be described in detail.

[0053] First, the vacuum cleaner 100 according to the present invention may be used in a state in which the handle 150 between the first support part 130 and the second support part 140 is folded, i.e., is locked.

[0054] In the present invention, the hanging part 142a

of the stopper 142 is exposed to the mounting groove 141 of the second support part 140 on which a rear front end of the outer rod 155 is mounted, and the hanging part 142a of the stopper 142 exposed to the outside of the mounting groove 141 is inserted into the hanging groove 155a of the outer rod 155 mounted on the mounting groove 141, as illustrated in FIG. 3A.

[0055] In this way, as the hanging part 142a of the stopper 142 is hung in the hanging groove 155a of the outer rod 155, the outer rod 155 is combined with and is fixed to the second support part 140 so that the handle 150 between the first support part 130 and the second support part 140 can be maintained in a folded state, i.e., in a locked state.

[0056] Thus, when the movement range of the main body 110 does not need to be increased, like in the case in which the user cleans the vicinity of a place where the user sits, if the handle 150 between the first support part 130 and the second support part 140 is locked, the user easily grasps the handle 150, and the vacuum cleaner 100 can be conveniently used.

[0057] Next, the vacuum cleaner 100 according to the present invention can be used in a state in which the handle 150 between the first support part 130 and the second support part 140 is unfolded, i.e., is unlocked, as illustrated in FIG. 2.

[0058] In the present invention, the hanging part 142a of the stopper 142 provided at the second support part 140 is separated from the hanging groove 155a of the outer rod 155 due to an operation of the button 144.

[0059] That is, as illustrated in FIG. 3B, when the hanging part 142a of the stopper 142 is separated from the hanging groove 155a of the outer rod 155 by pressing the button 144, the other end of the outer rod 155 may be unlocked from the mounting groove 141 of the second support part 140 and may be lifted upwardly.

[0060] In this case, one end of the inner rod 151 according to the present invention is fastened to the groove 131 of the first support part 130 using the hinge 132, and as the other end of the outer rod 155 is lifted upwardly, the handle 150 can be rotated toward the rear of the main body 110 based on the hinge 132.

[0061] Here, when the outer rod 155 is pulled backwardly in a state in which the fixing protrusion 153 inserted into the first length adjustment hole 158 of the outer rod 155 is pressurized, the outer rod 155 moves backwardly on the inner rod 151.

[0062] Thus, a state in which the inner rod 151 and the outer rod 155 overlap in the entire section, as illustrated in FIG. 4A, is changed to a state in which the outer rod 155 overlaps only a part of the inner rod 151, as illustrated in FIG. 4B so that the length of the handle 150 can be increased.

[0063] Also, since the fixing protrusion 153 of the inner rod 151 is inserted into the second length adjustment hole 159 of the outer rod 155, the outer rod 155 may be fixed to the inner rod 151 in a pulled state.

[0064] In this way, when a cleaning range is wide and

the movement range of the main body 110 needs to be increased, as illustrated in FIG. 2, the locked state of the handle 150 is released from the second support part 140 so as to adjust the direction and the length of the handle 150 so that the usage range of the vacuum cleaner 100 can be increased and the vacuum cleaner 100 can be conveniently used.

[0065] As described above, in the vacuum cleaner 100 according to the present invention, as one end of the handle 150 is pivotably installed at the first support part 130 and the other end of the handle 150 is detachably installed at the second support part 140, the direction and the length of the handle 150 can be adjusted according to a user's physical condition and a cleaning environment so that the handle 150 can be easily grasped, the usage range of the vacuum cleaner 100 can be further increased in a state in which the handle 150 is grasped and the vacuum cleaner 100 can be easily used while relieving user fatigue.

[0066] A handle of a vacuum cleaner according to the present invention has one end that is pivotably installed at a first support part and the other end that is detachably installed at a second support part so that the handle can be pivoted and folded between the first support part and the second support part. Thus, the handle can be pivoted and folded according to a user's physical condition or a cleaning environment.

[0067] Furthermore, since the direction and the length of the handle can be adjusted, it is easy to grasp the handle so that user fatigue can be relieved, and the length of the handle can be adjusted so that the usage range of the vacuum cleaner can be increased and the vacuum cleaner can be easily used.

[0068] It will be apparent to those skilled in the art that various modifications can be made to the above-described exemplary embodiments of the present invention without departing from the spirit or scope of the invention. Thus, it is intended that the present invention covers all such modifications provided they come within the scope of the appended claims and their equivalents.

Claims

1. A vacuum cleaner comprising:
 - a main body;
 - a first support part and a second support part that are installed at an outer side of the main body and are spaced apart from each other by a predetermined distance; and
 - a handle combined between the first support part and the second support part, wherein one end of the handle is pivotably installed at the first support part, and the other end of the handle is detachably installed at the second support part.

2. The vacuum cleaner of claim 1, wherein the handle comprises:
 - an inner rod having one end that is pivotably installed at the first support part; and
 - an outer rod that slides along an outer circumferential surface of a lengthwise direction of the inner rod.

3. The vacuum cleaner of claim 2, wherein a guide hole is formed in an outer surface of one side of the inner rod of the handle and extends in a lengthwise direction of the inner rod of the handle, and a fixing protrusion is installed at the other end of the inner rod and comes in an inner side of the inner rod as an external force is applied to one side of the fixing protrusion, and the fixing protrusion returns to its original state as the external force is removed from the fixing protrusion.

4. The vacuum cleaner of claim 2, wherein an inner groove is formed in the inner rod, and an auxiliary protrusion is formed at the outer rod.

5. The vacuum cleaner of claim 2 or 3, wherein a plurality of length adjustment holes in which the fixing protrusions of the inner rod are inserted, are formed in one side of the outer rod, and the length of the handle is adjusted at multiple stages while sliding along the lengthwise direction of the inner rod.

6. The vacuum cleaner of claim 2, wherein a guide protrusion that moves along the guide hole of the inner rod is formed at an inner surface of one side of the outer rod.

7. The vacuum cleaner of claim 1, wherein the second support part comprises a stopper having a top end on which a hanging part is formed, a prop part that supports one side of the stopper, and a detachment unit configured of a button that is hinge-coupled to the stopper.

FIG. 1

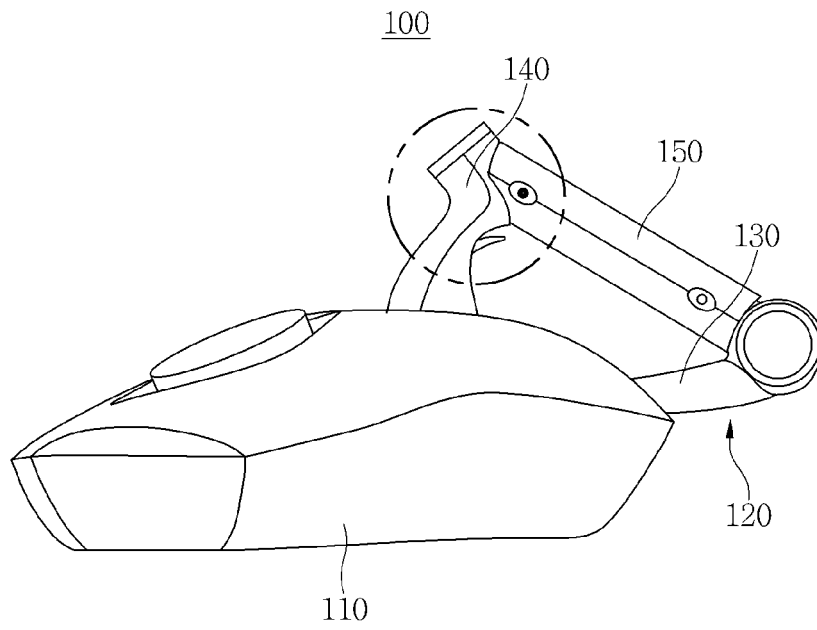

FIG. 2

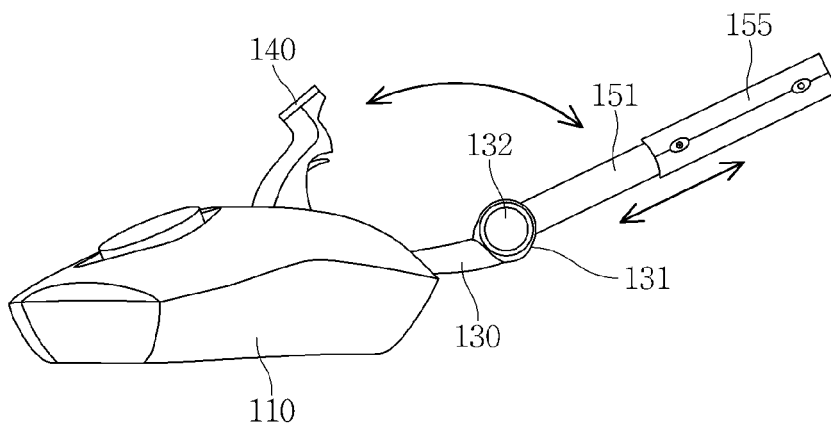

FIG. 3A

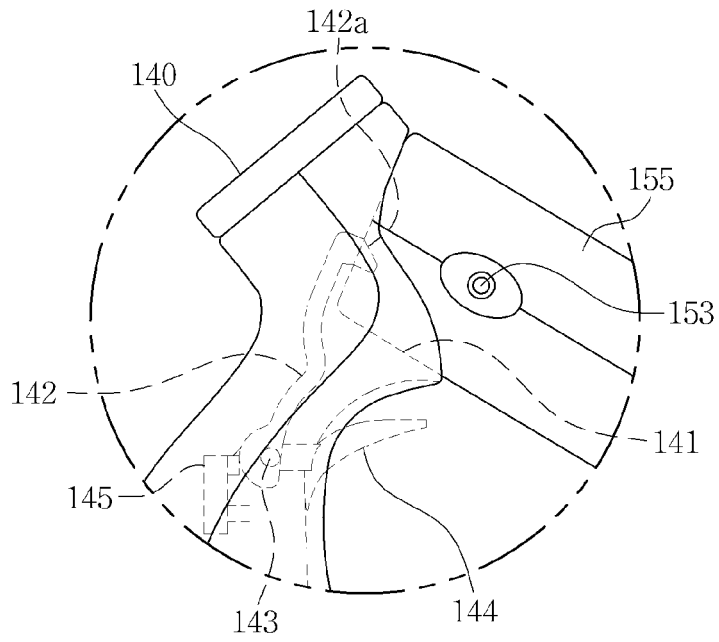

FIG. 3B

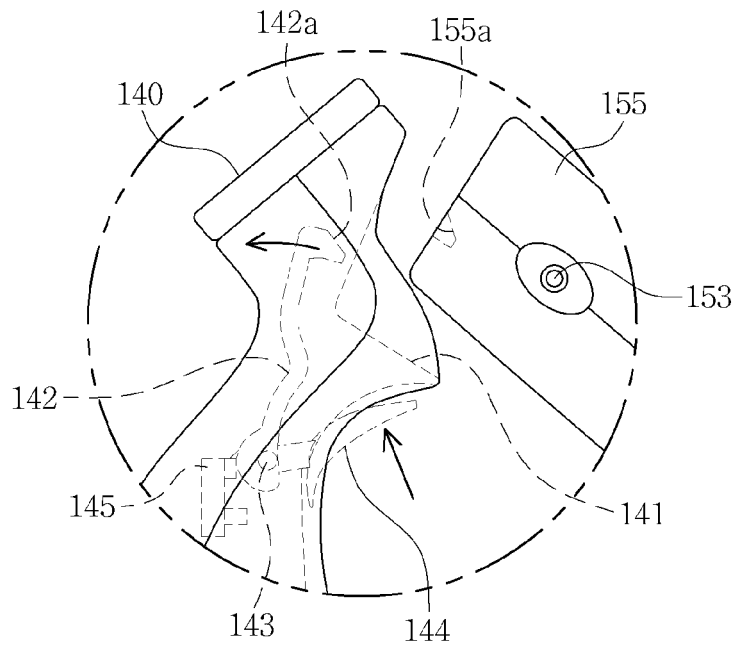

FIG. 4A

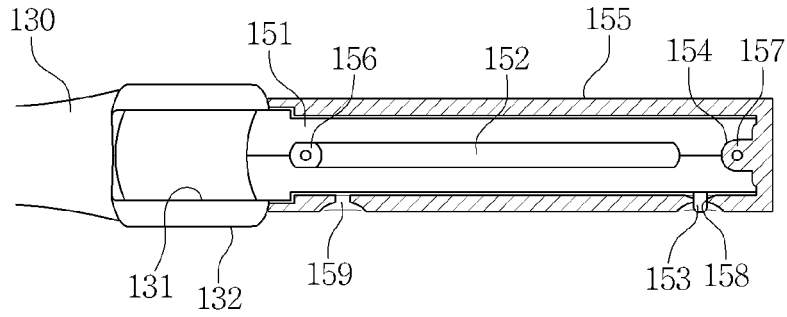
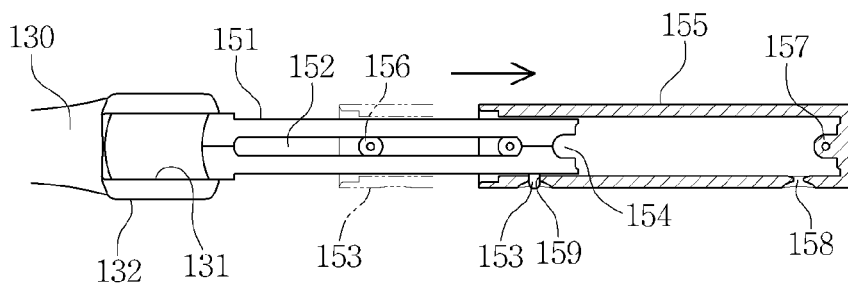

FIG. 4B





EUROPEAN SEARCH REPORT

Application Number
EP 13 18 4516

5

10

15

20

25

30

35

40

45

50

55

DOCUMENTS CONSIDERED TO BE RELEVANT			
Category	Citation of document with indication, where appropriate, of relevant passages	Relevant to claim	CLASSIFICATION OF THE APPLICATION (IPC)
X	EP 1 190 660 A2 (DAEWOO ELECTRONICS CO LTD [KR] DAEWOO ELECTRONICS CORP [KR]) 27 March 2002 (2002-03-27)	1,7	INV. A47L9/32
Y	* paragraphs [0033], [0087] - [0094]; figures 4,18,19,26-30 *	2-6	
Y	US 4 662 026 A (SUMERAU WILLIAM R [US] ET AL) 5 May 1987 (1987-05-05) * the whole document *	2-6	
X	DE 10 35 330 B (BAUMGARTEN K G) 31 July 1958 (1958-07-31) * the whole document *	1	
X	US 4 644 605 A (JOSS MICHAEL S [US] ET AL) 24 February 1987 (1987-02-24) * columns 1-3 *	1	
X	DE 34 35 878 A1 (LICENTIA GMBH [DE]) 10 April 1986 (1986-04-10) * the whole document *	1	
			TECHNICAL FIELDS SEARCHED (IPC)
A	CN 201 398 936 Y (SUZHOU CLEANPLUS ELECTRIC APPLIANCE CO LTD) 10 February 2010 (2010-02-10) * the whole document *	1-7	A47L
A	EP 2 529 652 A1 (BLACK & DECKER INC [US]) 5 December 2012 (2012-12-05) * the whole document *	1-7	
The present search report has been drawn up for all claims			
Place of search Munich		Date of completion of the search 3 November 2014	Examiner Martin Gonzalez, G
CATEGORY OF CITED DOCUMENTS X : particularly relevant if taken alone Y : particularly relevant if combined with another document of the same category A : technological background O : non-written disclosure P : intermediate document		T : theory or principle underlying the invention E : earlier patent document, but published on, or after the filing date D : document cited in the application L : document cited for other reasons & : member of the same patent family, corresponding document	

EPO FORM 1503 03/82 (P04/C01)

ANNEX TO THE EUROPEAN SEARCH REPORT
ON EUROPEAN PATENT APPLICATION NO.

EP 13 18 4516

This annex lists the patent family members relating to the patent documents cited in the above-mentioned European search report.
The members are as contained in the European Patent Office EDP file on
The European Patent Office is in no way liable for these particulars which are merely given for the purpose of information.

03-11-2014

Patent document cited in search report	Publication date	Patent family member(s)	Publication date
EP 1190660 A2	27-03-2002	DE 60123725 T2 EP 1190660 A2 ES 2273799 T3 KR 20020023474 A US 2004006842 A1	23-08-2007 27-03-2002 16-05-2007 29-03-2002 15-01-2004
US 4662026 A	05-05-1987	CA 1271904 A1 US 4662026 A	24-07-1990 05-05-1987
DE 1035330 B	31-07-1958	NONE	
US 4644605 A	24-02-1987	CA 1261560 A1 US 4644605 A	26-09-1989 24-02-1987
DE 3435878 A1	10-04-1986	NONE	
CN 201398936 Y	10-02-2010	NONE	
EP 2529652 A1	05-12-2012	AU 2012203208 A1 CA 2778511 A1 CN 102805593 A EP 2529652 A1 JP 2012250036 A US 2012304417 A1	20-12-2012 01-12-2012 05-12-2012 05-12-2012 20-12-2012 06-12-2012

EPO FORM P0459

For more details about this annex : see Official Journal of the European Patent Office, No. 12/82

REFERENCES CITED IN THE DESCRIPTION

This list of references cited by the applicant is for the reader's convenience only. It does not form part of the European patent document. Even though great care has been taken in compiling the references, errors or omissions cannot be excluded and the EPO disclaims all liability in this regard.

Patent documents cited in the description

- KR 200447957 [0005]
- KR 100389289 [0006]