



(11) **EP 2 837 881 A1**

(12) **EUROPEAN PATENT APPLICATION**

(43) Date of publication:
18.02.2015 Bulletin 2015/08

(51) Int Cl.:
F21V 29/00 (2015.01) F21K 99/00 (2010.01)
F21Y 101/02 (2006.01) F21Y 105/00 (2006.01)

(21) Application number: **14160690.5**

(22) Date of filing: **19.03.2014**

(84) Designated Contracting States:
AL AT BE BG CH CY CZ DE DK EE ES FI FR GB GR HR HU IE IS IT LI LT LU LV MC MK MT NL NO PL PT RO RS SE SI SK SM TR
Designated Extension States:
BA ME

(72) Inventors:
• **Lan, Hai**
New Tapei City, (TW)
• **Yang, Li-Chang**
Jhonghe City, Taipei County (TW)

(30) Priority: **16.08.2013 TW 102215504 U**

(74) Representative: **Viering, Jentschura & Partner**
Patent- und Rechtsanwälte
Kennedydamm 55 / Roßstrasse
40476 Düsseldorf (DE)

(71) Applicant: **ARC Solid-State Lighting Corporation**
Jhonghe, New Taipei City (TW)

(54) **Light module and light assembly using the same**

(57) A light module (10) includes a luminous component (12) and a heat dissipating component (14). One side of the heat dissipating component (14) is in thermal contact with the luminous component (12). The heat dissipating component (14) has a first chamber (145), a second chamber (146) and two channels (148) connecting the first chamber (145) and the second chamber (146). The distance from the second chamber (146) to the luminous component (12) is greater than that from the first chamber (145) to the luminous component (12), and a working fluid (19) is filled in the first chamber (145). When the working liquid (19) absorbs heat generated from the luminous component (12), the working liquid (19) vaporizes from the liquid state to the gaseous state and flows into the second chamber (146) via one of the two channels (148) for the heat dissipation. After the working liquid (19) in the second chamber (146) condenses from the gaseous state to the liquid state, it flows back to the first chamber (145) via the other channel.

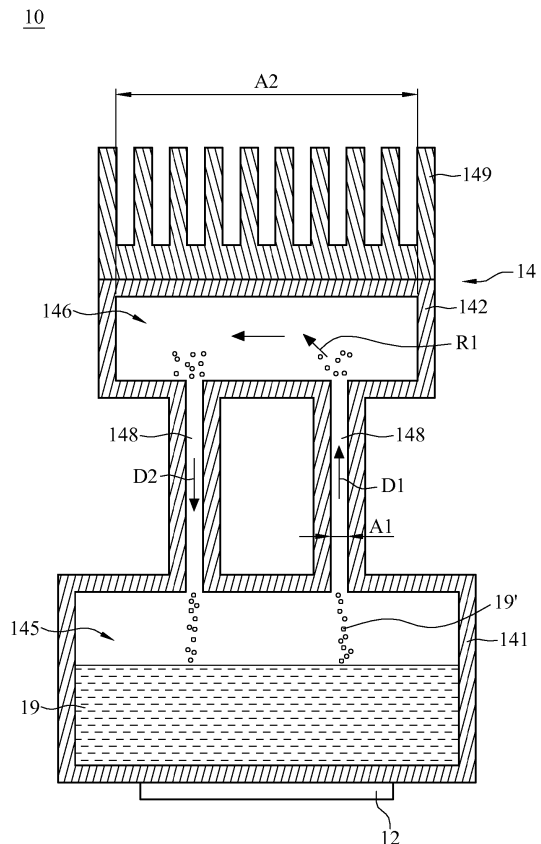

FIG.2

EP 2 837 881 A1

Description

Technical Field

[0001] The disclosure relates to a light module and a light assembly using the same, more particularly to a light module utilizing a phase-change cooling loop and a light assembly using the light module.

Background

[0002] Although having not replaced all of the traditional incandescent lamps, light-emitting diodes (LEDs) have become popular lighting devices. LEDs have advantages of being environmentally friendly and energy saving. In addition, LEDs have longer lifespan than the incandescent lamps. A plurality of LEDs together can be a light source with high-power and high-brightness, thereby being capable of replacing indoor and outdoor incandescent lamps. Since LEDs are eco-friendly, they are expected to be the future of the lighting industry.

[0003] Nevertheless, today's heat dissipation process of the LED is applied by thermal conduction and the results thereof are not satisfactory. Moreover, the fins need to be disposed near the LED so the space allocation of components of the LED is not flexible. Therefore, it is crucial to design a heat dissipation system for the LED which can overcome these problems.

SUMMARY

[0004] The disclosure is a light module for solving the unsatisfactory heat dissipation performance and a light assembly using the same.

[0005] A light module comprises a luminous component and a heat dissipating component. One side of the heat dissipating component is in thermal contact with the luminous component. The heat dissipating component has a first chamber, a second chamber and two channels connecting the first chamber and the second chamber. The distance from the second chamber to the luminous component is greater than that from the first chamber to the luminous component, and a working fluid is filled in the first chamber. When the working liquid absorbs heat generated from the luminous component, the working liquid vaporizes from the liquid state to the gaseous state and flows into the second chamber via one of the two channels for the heat dissipation. After the working liquid in the second chamber condenses from the gaseous state to the liquid state, it flows back to the first chamber via the other channel.

[0006] A light assembly comprises a canopy and a plurality of light modules 10 disposed on one side of the canopy. Each of the light modules comprises a luminous component and a heat dissipating component. One side of the heat dissipating component is in thermal contact with the luminous component. The heat dissipating component has a first chamber, a second chamber and two

channels connecting the first chamber and the second chamber. The distance from the second chamber to the luminous component is greater than that from the first chamber to the luminous component, and a working fluid is filled in the first chamber. When the working liquid absorbs heat generated from the luminous component, the working liquid vaporizes from the liquid state to the gaseous state and flows into the second chamber via one of the two channels for the heat dissipation. After the working liquid in the second chamber condenses from the gaseous state to the liquid state, it flows back to the first chamber via the other channel.

[0007] Therefore, a cyclic close-loop is formed by the arrangement of the two channels, and the convection of the working liquid as well as the working gas accelerates the heat conduction. This structure design may omit the active heat dissipating component and can significantly improve the heat dissipation effect.

BRIEF DESCRIPTION OF THE DRAWINGS

[0008] The present disclosure will become more fully understood from the detailed description given hereinbelow, along with the accompanying drawings which are for illustration only, thus are not limitative of the present disclosure, and wherein:

FIG. 1 is a perspective view of a light module according to the first embodiment of the disclosure;

FIG. 2 is a sectional view of FIG. 1;

FIG. 3 is a perspective view of a light module according to the second embodiment of the disclosure;

FIG. 4 is a sectional view of FIG. 3; and

FIG. 5 is a perspective view of a light assembly according to an embodiment of the disclosure.

DETAILED DESCRIPTION

[0009] In the following detailed description, for purposes of explanation, numerous specific details are set forth in order to provide a thorough understanding of the disclosed embodiments. It will be apparent, however, that one or more embodiments may be practiced without these specific details. In other instances, well-known structures and devices are schematically shown in order to simplify the drawing.

[0010] FIG. 1 is a perspective view of a light module according to the first embodiment of the disclosure; FIG. 2 is a sectional view of FIG. 1. As seen in FIGs. 1 and 2, in this embodiment, the light module 10 comprises a luminous component 12 and a heat dissipating component 14. The luminous component 12 of the disclosure is a solid-state light-emitting element. In this embodiment, the luminous component 12 is a light-emitting diode, but

it is not limited thereto. The heat dissipating component 14 has a first main body 141, a second main body 142, a first chamber 145, a second chamber 146, two channels 148, a fin group 149 and a working liquid 19.

[0011] One side of the first main body 141 is in thermal contact with the luminous component 12. The first chamber 145 is located inside the first main body 141, while the second chamber 146 is located inside the second main body 142. The fin group 149 is disposed on the second main body 142. The two channels 148 are located between the first chamber 145 and the second chamber 146 and connect them. In this embodiment, the number of the channels is two, but the disclosure is not limited thereto. In other embodiments, the number of the channels can be adjusted if needed. The distance from the second chamber 146 to the luminous component 12 is greater than that from the first chamber 145 to the luminous component 12, and a working fluid 19 is filled in the first chamber 145. In this embodiment, the working liquid 19 is water, but it is not limited thereto. In other embodiments, the working liquid 19 may be refrigerant, methanol, ethanol, diethyl ether or any liquid which can facilitate heat conduction. Furthermore, in this embodiment, the cross-sectional area A1 of each of the two channels 148 is much smaller than the cross-sectional area A2 of the second chamber 146.

[0012] Now the heat dissipation process of the heat dissipating component 14 dissipating the heat generated by the luminous component 12 will be illustrated. When the luminous component 12 generates heat, it is transferred to the first chamber 145 in the first main body 141. After the working liquid 19 in the first chamber 145 absorbs the heat generated by the luminous component 12, it vaporizes, from the liquid state, into the working gas 19'. The working gas 19' rises and flows into the second chamber 146 of the second main body 142 along a first direction D1 (as shown in FIG. 2). In this embodiment, since the fin group 149 is disposed on the second main body 142, the heat of the working gas 19' can be dissipated via the fin group 149. However, the disclosure is not limited thereto. In other embodiments, the heat of the working gas 19' can be directly dissipated to the external environment by the second main body 142. Since the heat is dissipated after the working gas 19' enters the second chamber 146, the working gas 19' gradually condenses into the working liquid 19. Subsequently, the working liquid 19 flows back to the first chamber via the other channel 148 along a second direction D2. Furthermore, in other embodiments, since the cross-sectional area A1 of the channel 148 is much smaller than the cross-sectional area A2 of the second chamber 146, a great pressure difference exists between them. Therefore, the working liquid 19' flows into the second chamber 146' as a high-speed airflow R1 along the first direction D1, which accelerates the heat conduction and the convection.

[0013] In the light module 10 of the first embodiment, the working liquid 19 vaporizes into the working gas 19'

for accelerating the heat conduction, and the working gas 19' flows into the second chamber 146 via one of the two channels 148 for heat dissipation. After the working gas 19' condenses into the working liquid 19, it flows back to the first chamber 145 via the other channel 148. In this way, a cyclic close-loop is created and it can contribute to a better cooling effect due to the convection. Moreover, in this way, the disposition of an active heat dissipating component is omitted. By the arrangement of the two channels, the light module 10 can perform remote heat dissipation. That is, the part of the structure for heat conduction is separated from the part of the structure for heat dissipation. Thus, the interior space allocation of the whole structure is flexible. Additionally, in this embodiment, the working liquid 19' flows into the second chamber 146' as a high-speed airflow R1 along the first direction D1 which accelerates the heat conduction and the convection.

[0014] Moreover, a light module with a different structural design is provided. Referring to FIG. 3 and FIG. 4, FIG. 3 is a perspective view of a light module according to the second embodiment of the disclosure; FIG. 4 is a sectional view of FIG. 3. In the second embodiment, a light module 20 comprises a luminous component 22 and a heat dissipating component 24. In this embodiment, the luminous component 22 is a light-emitting diode, but it is not limited thereto. The heat dissipating component 24 has a main body 241, a first chamber 245, a second chamber 246, two channels 248, a fin group 249 and a working liquid 29.

[0015] One side of the main body 241 is in thermal contact with the luminous component 22. The first chamber 245, the second chamber 246 and the two channels 248 are located inside the main body 241. The fin group 249 is disposed on one side of the main body 242 away from the luminous component 22. The two channels 248 connect the first chamber 245 and the second chamber 246. In this embodiment, the number of the channels 248 is two, but it is not limited thereto. In other embodiments, the number of the channels can be adjusted if needed. The distance from the second chamber 246 to the luminous component 22 is greater than that from the first chamber 245 to the luminous component 22, and a working fluid 29 is filled in the first chamber 245. In this embodiment, the working liquid 29 is water, but it is not limited thereto. In other embodiments, the working liquid 29 may be refrigerant, methanol, ethanol, diethyl ether or any liquid which can facilitate heat conduction. Furthermore, in this embodiment, the cross-sectional area A1 of each of the two channels 248 is much smaller than the cross-sectional area A2 of the second chamber 246.

[0016] The heat dissipation process of the light module 20 of the second embodiment is similar to the light module 10 of the first embodiment, so it is not illustrated again.

[0017] Furthermore, a light assembly is provided. FIG. 5 is a perspective view of a light assembly according to an embodiment of the disclosure. As seen in FIG. 5, the light assembly 30 comprises a canopy 40 and a plurality

of light modules 10 of the first embodiment. The light modules 10 are disposed on one side of the canopy 40, thereby forming a canopy LED device. However, in other embodiments, the light assembly 30 may comprise a canopy 40 and a plurality of light modules 20 of the second embodiment. That is, both the light module 10 and the light module 20 may be applied to the canopy LED device.

[0018] To sum up, the cyclic close-loop is formed by the arrangement of the two channels, and the convection of the working liquid as well as the working gas accelerates the heat conduction. This structure design may omit the active heat dissipating component and can significantly improve the heat dissipation effect.

[0019] Additionally, the cross-sectional area of each of the two channels is much smaller than the cross-sectional area of the second chamber so that the great pressure difference exists between them. Thereby, the working gas can flow into the second chamber as a high-speed airflow, thereby accelerating the heat conduction and convection. Consequently, the heat dissipation performance is improved considerably.

Claims

1. A light module 10 comprising:

a luminous component 12 ; and
a heat dissipating component 14, wherein one side of the heat dissipating component 14 is in thermal contact with the luminous component 12, the heat dissipating component 14 has a first chamber 145, a second chamber 146 and two channels 148 connecting the first chamber 145 and the second chamber 146, the distance from the second chamber 146 to the luminous component 12 is greater than that from the first chamber 145 to the luminous component 12, and a working fluid 19 is filled in the first chamber 145,

wherein, when the working liquid 19 absorbs heat generated from the luminous component 12, the working liquid 19 vaporizes from the liquid state to the gaseous state and flows into the second chamber 146 via one of the two channels 148 for the heat dissipation, and after the working liquid 19 in the second chamber 146 condenses from the gaseous state to the liquid state, it flows back to the first chamber 145 via the other channel.

2. The light module 10 according to claim 1, wherein the cross-sectional area of each of the two channels 148 is smaller than that of the second chamber 146, so that the working liquid 19 flows into the second chamber 146 in a high speed, via one of the two channels 148.

3. The light module 10 according to claim 1, wherein the heat dissipating component further comprises a main body 241 and a fin group 149, one side of the main body is in thermal contact with the luminous component 12, the fin group 149 is disposed on one side of the main body 241 away from the luminous component 12, and the first chamber 145, the second chamber 146 as well as the two channels 148 are located inside the main body 241.

4. The light module 10 according to claim 1, wherein the heat dissipating component further comprises a first main body 141, a second main body 142 and a fin group 149, one side of the first main body 141 is in thermal contact with the luminous component 12, the first chamber 145 is inside the first main body 141, the second chamber 146 is inside the second main body 142, the fin group 149 is disposed on the second main body 142, and the two channels 148 are located between the first main body 141 and the second main body 142.

5. The light module 10 according to claim 1, wherein the working liquid 19 is water, methanol, ethanol or diethyl ether.

6. The light module 10 according to claim 1, wherein the luminous component 12 is a light-emitting diode.

7. A light assembly 30 comprising:

a canopy 40; and
a plurality of light modules 10 disposed on one side of the canopy 40, each of the light modules 10 comprising:

a luminous component 12; and
a heat dissipating component, wherein one side of the heat dissipating component is in thermal contact with the luminous component 12, the heat dissipating component has a first chamber 145, a second chamber 146 and two channels 148 connecting the first chamber 145 and the second chamber 146, the distance from the second chamber 146 to the luminous component 12 is greater than that from the first chamber 145 to the luminous component 12, and a working liquid 19 is filled in the first chamber 145, wherein, when the working liquid 19 absorbs heat generated from the luminous component 12, the working liquid 19 vaporizes from the liquid state to the gaseous state and flows into the second chamber 146 via one of the two channels 148 for the heat dissipation, and after the working liquid 19 in the second chamber 146 condenses from the gaseous state to the liquid state, it

flows back to the first chamber 145 via the other channel.

8. The light assembly 30 according to claim 7, wherein the cross-sectional area of each of the two channels 148 is smaller than that of the second chamber 146, so that the working liquid 19 flows into the second chamber 146 in a high speed, via one of the two channels 148.

5

10

9. The light assembly 30 according to claim 7, wherein the heat dissipating component further comprises a main body 241 and a fin group 149, one side of the main body 241 is in thermal contact with the luminous component 12, the fin group 149 is disposed on one side of the main body 241 away from the luminous component 12, and the first chamber 145, the second chamber 146 as well as the two channels 148 are located inside the main body 241.

15

20

10. The light assembly 30 according to claim 7, wherein the heat dissipating component further comprises a first main body 141, a second main body 142 and a fin group 149, one side of the first main body 141 is in thermal contact with the luminous component 12, the first chamber 145 is inside the first main body 141, the second chamber 146 is inside the second main body 142, the fin group 149 is disposed on the second main body 142, and the two channels 148 are located between the first main body 141 and the second main body 142.

25

30

11. The light assembly 30 according to claim 7, wherein the working liquid 19 is water, methanol, ethanol or diethyl ether.

35

12. The light assembly 30 according to claim 7, wherein the luminous component 12 is a light-emitting diode.

40

45

50

55

10

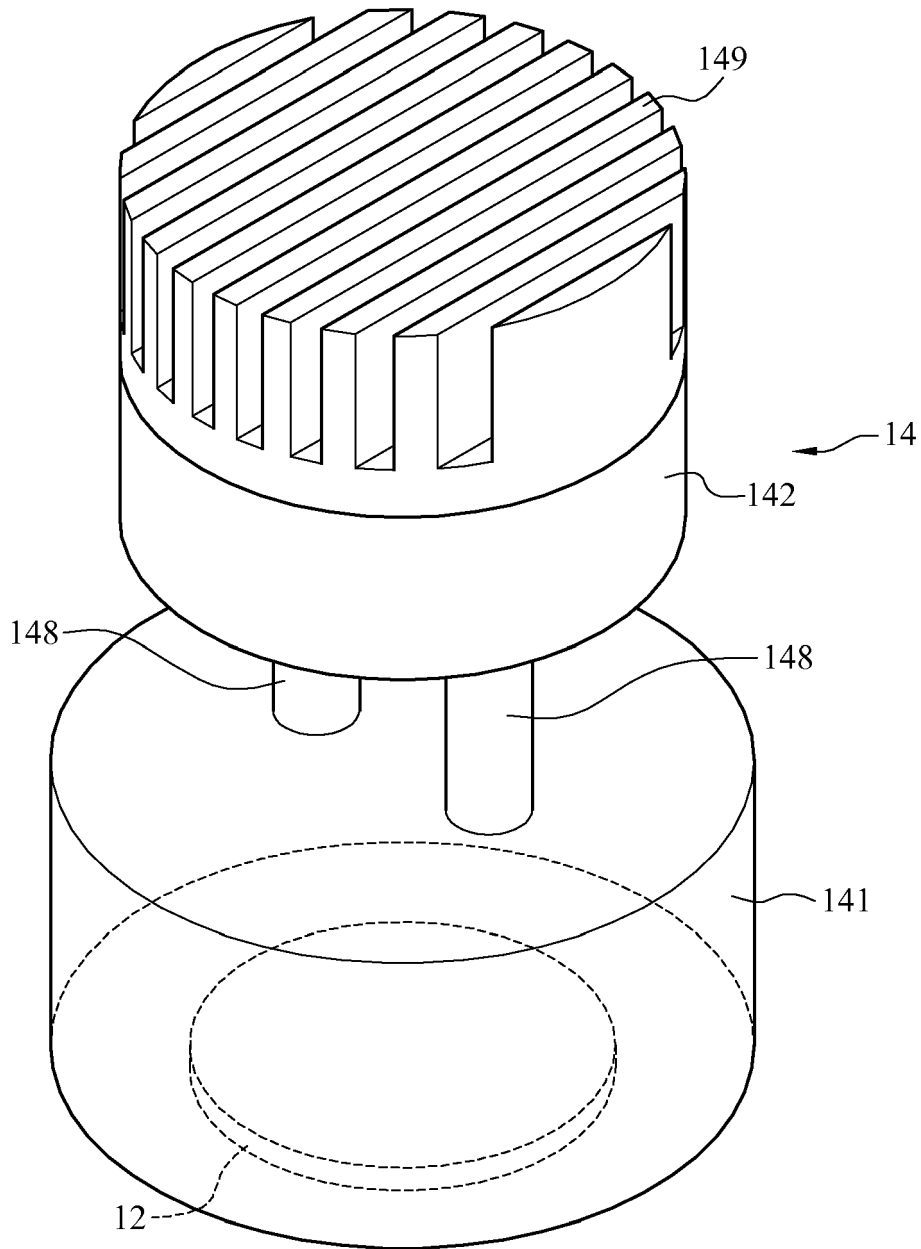

FIG.1

10

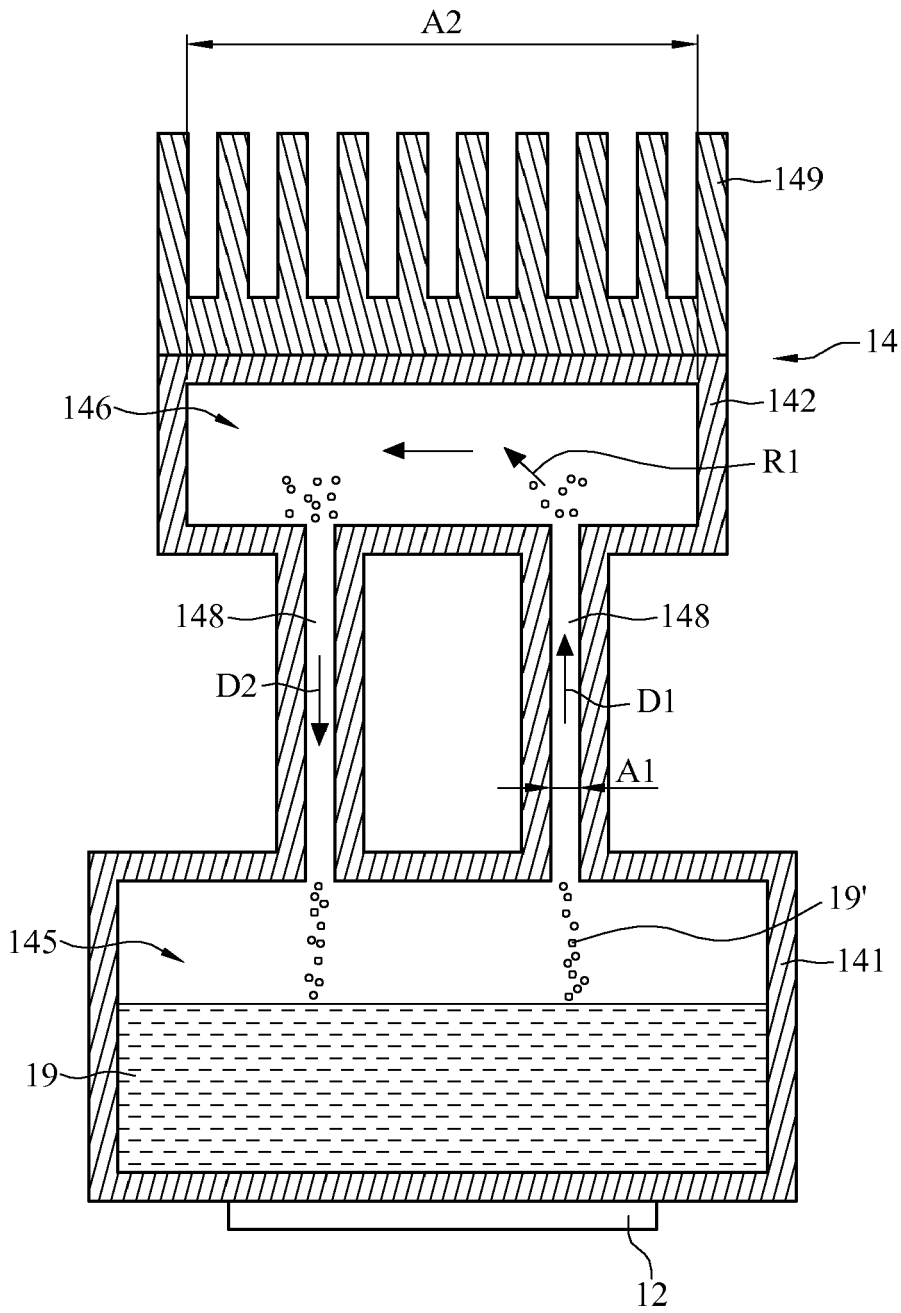

FIG.2

20

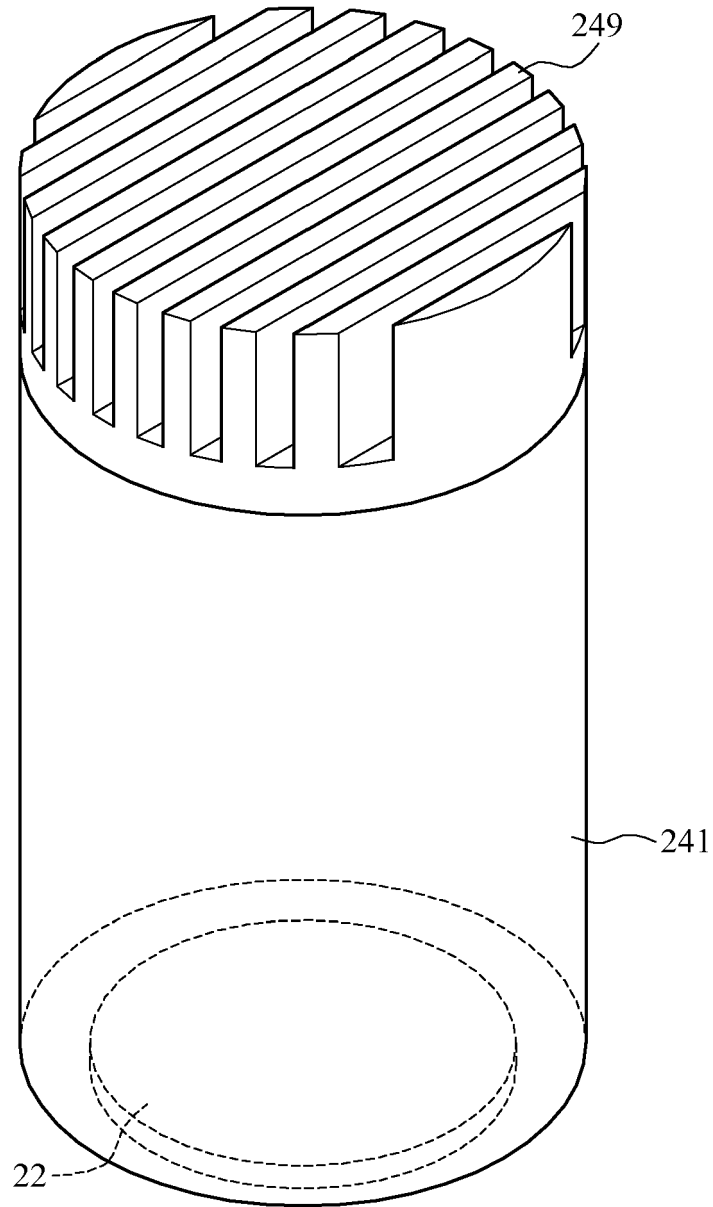

FIG. 3

20

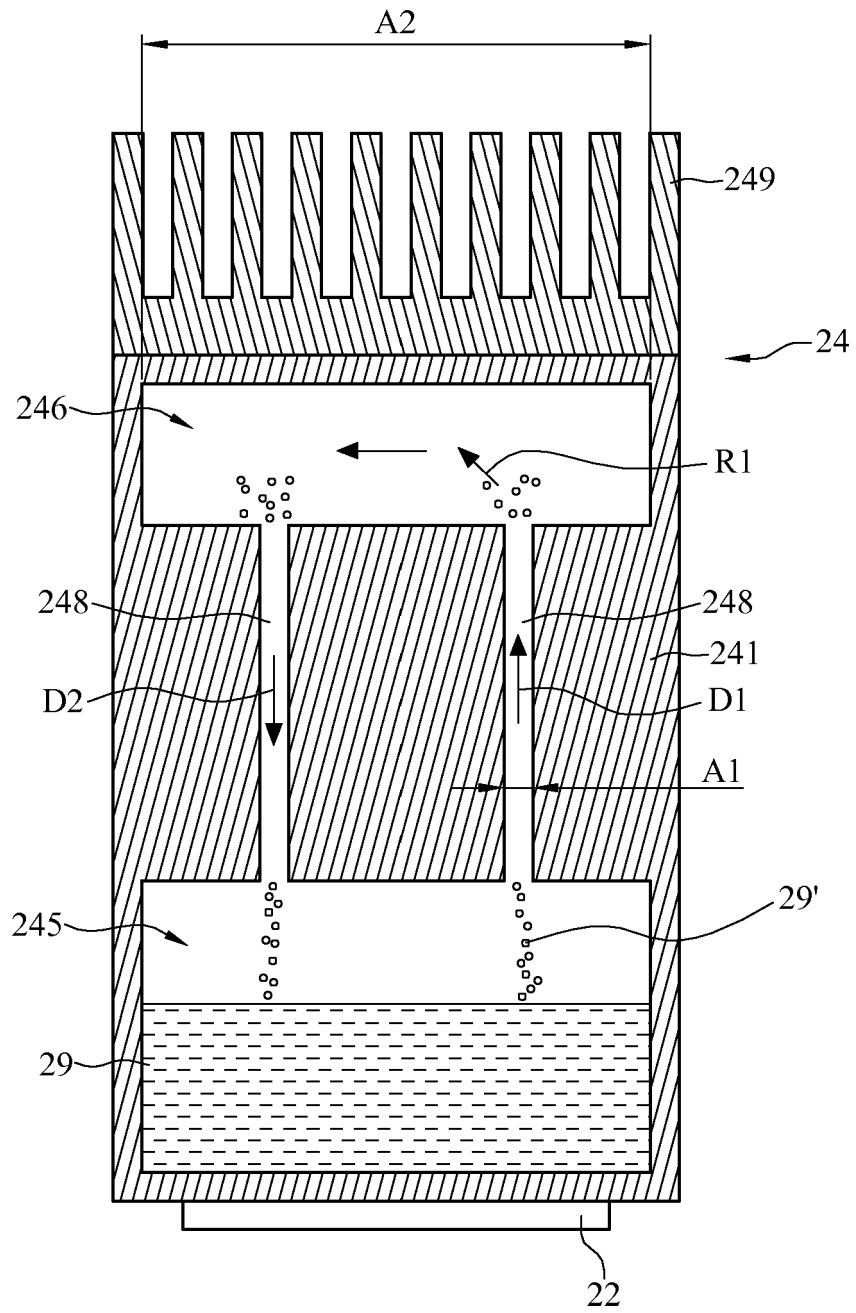

FIG.4

30

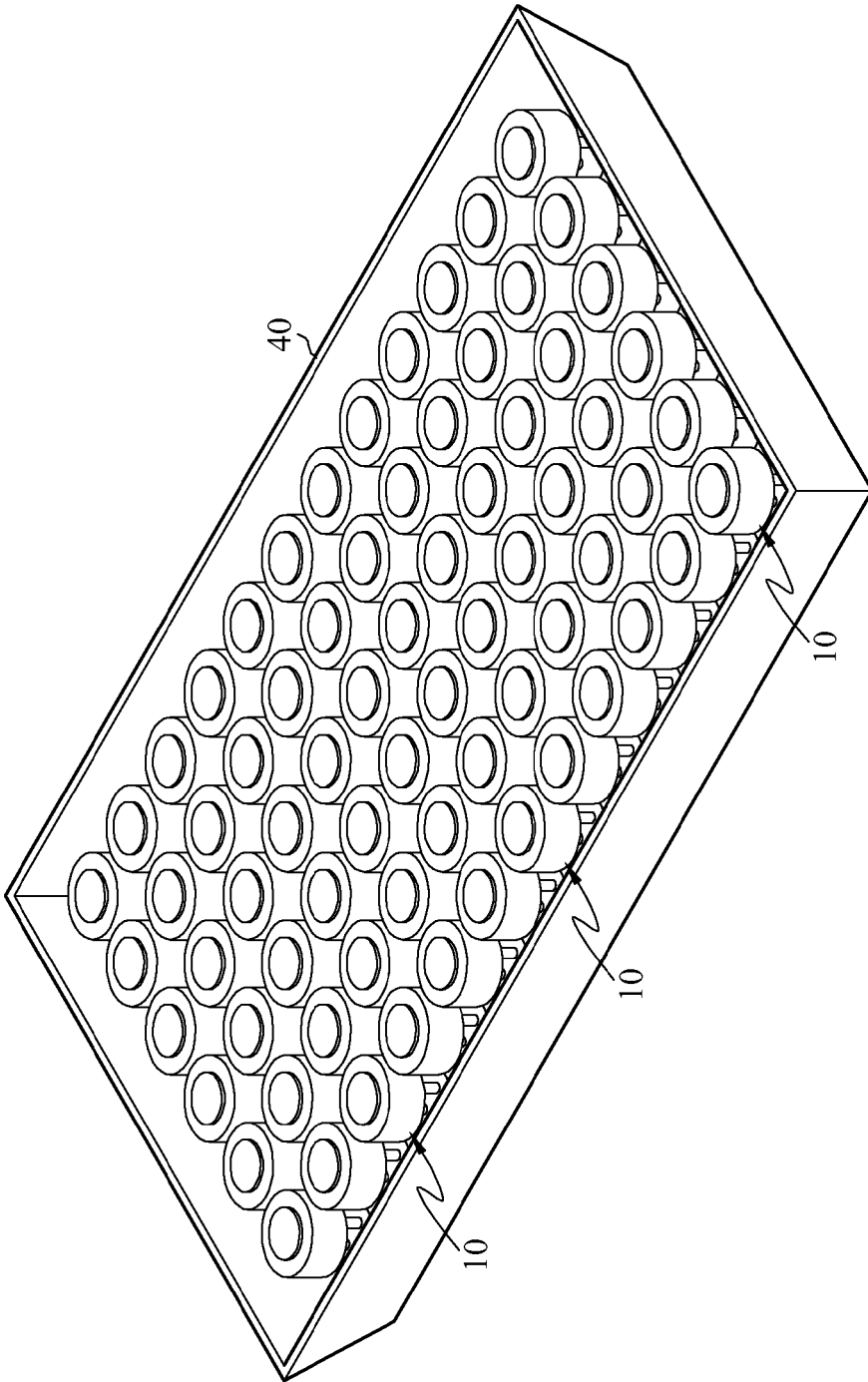

FIG.5



EUROPEAN SEARCH REPORT

Application Number
EP 14 16 0690

5

10

15

20

25

30

35

40

45

50

55

DOCUMENTS CONSIDERED TO BE RELEVANT			
Category	Citation of document with indication, where appropriate, of relevant passages	Relevant to claim	CLASSIFICATION OF THE APPLICATION (IPC)
X	US 2011/267815 A1 (GHIU CAMIL-DANIEL [US] ET AL) 3 November 2011 (2011-11-03) * figures 1, 3, 4 * * paragraphs [0021] - [0024] * * paragraphs [0009] - [0013], [0035] - [0040] * -----	1,2,5-12	INV. F21V29/00 F21K99/00 ADD. F21Y101/02 F21Y105/00
X	US 2010/172144 A1 (LIU TAY-JIAN [TW]) 8 July 2010 (2010-07-08) * figures 1, 2 * * paragraphs [0020] - [0025], [0028] - [0031] * -----	1-3,5,6	
X	US 2010/038660 A1 (SHUJA AHMED [US]) 18 February 2010 (2010-02-18) * figures 5A, 5B, 6 * * paragraphs [0072] - [0080] * -----	1,2,4-6	
			TECHNICAL FIELDS SEARCHED (IPC)
			F21V F21K F21Y
The present search report has been drawn up for all claims			
Place of search		Date of completion of the search	Examiner
The Hague		19 September 2014	Vida, Gyorgy
CATEGORY OF CITED DOCUMENTS		T : theory or principle underlying the invention E : earlier patent document, but published on, or after the filing date D : document cited in the application L : document cited for other reasons & : member of the same patent family, corresponding document	
X : particularly relevant if taken alone Y : particularly relevant if combined with another document of the same category A : technological background O : non-written disclosure P : intermediate document			

1
EPO FORM 1503 03.82 (P04C01)

**ANNEX TO THE EUROPEAN SEARCH REPORT
ON EUROPEAN PATENT APPLICATION NO.**

EP 14 16 0690

5

This annex lists the patent family members relating to the patent documents cited in the above-mentioned European search report. The members are as contained in the European Patent Office EDP file on The European Patent Office is in no way liable for these particulars which are merely given for the purpose of information.

19-09-2014

10

Patent document cited in search report	Publication date	Patent family member(s)	Publication date
US 2011267815 A1	03-11-2011	CA 2797993 A1	10-11-2011
		CN 102859275 A	02-01-2013
		EP 2567150 A1	13-03-2013
		KR 20130063508 A	14-06-2013
		US 2011267815 A1	03-11-2011
		US 2014071688 A1	13-03-2014
		WO 2011140157 A1	10-11-2011

US 2010172144 A1	08-07-2010	CN 101769458 A	07-07-2010
		US 2010172144 A1	08-07-2010

US 2010038660 A1	18-02-2010	US 2010038660 A1	18-02-2010
		US 2012205706 A1	16-08-2012

15

20

25

30

35

40

45

50

55

EPO FORM P0459

For more details about this annex : see Official Journal of the European Patent Office, No. 12/82