

(19)



(11)

EP 2 842 452 B1

(12)

EUROPEAN PATENT SPECIFICATION

(45) Date of publication and mention of the grant of the patent:
20.02.2019 Bulletin 2019/08

(51) Int Cl.:
A45D 27/46^(2006.01) B26B 19/44^(2006.01)

(21) Application number: **13781281.4**

(86) International application number:
PCT/JP2013/001557

(22) Date of filing: **11.03.2013**

(87) International publication number:
WO 2013/161161 (31.10.2013 Gazette 2013/44)

(54) CLEANING DEVICE FOR ELECTRICAL APPLIANCE

REINIGUNGSVORRICHTUNG FÜR ELEKTRISCHE VORRICHTUNG

DISPOSITIF DE NETTOYAGE D'APPAREIL ÉLECTROMÉNAGER

(84) Designated Contracting States:
AL AT BE BG CH CY CZ DE DK EE ES FI FR GB GR HR HU IE IS IT LI LT LU LV MC MK MT NL NO PL PT RO RS SE SI SK SM TR

- **TANIGUCHI, Fumio**
Chuo-ku, Osaka 540-6207 (JP)
- **IKUTA, Toshio**
Chuo-ku, Osaka 540-6207 (JP)
- **UEDA, Yasunori**
Chuo-ku, Osaka 540-6207 (JP)

(30) Priority: **27.04.2012 JP 2012103401**

(43) Date of publication of application:
04.03.2015 Bulletin 2015/10

(74) Representative: **Grünecker Patent- und Rechtsanwälte PartG mbB Leopoldstraße 4 80802 München (DE)**

(73) Proprietor: **Panasonic Corporation Kadoma-shi, Osaka 571-8501 (JP)**

(72) Inventors:
• **SONE, Daisuke**
Chuo-ku, Osaka 540-6207 (JP)

(56) References cited:
EP-A1- 1 992 248 EP-A1- 2 233 032
WO-A1-01/10262 WO-A1-2004/064569
JP-B2- 3 652 393

EP 2 842 452 B1

Note: Within nine months of the publication of the mention of the grant of the European patent in the European Patent Bulletin, any person may give notice to the European Patent Office of opposition to that patent, in accordance with the Implementing Regulations. Notice of opposition shall not be deemed to have been filed until the opposition fee has been paid. (Art. 99(1) European Patent Convention).

Description

Technical Field

[0001] The invention relates to a cleaning device for an electrical appliance such as an electric razor or a depilator, which needs to be regularly cleaned.

Background Art

[0002] For example, JP Pat. No. 3652393 (US Pat. No. 5,711,328) discloses a cleaning device. The cleaning device includes a cradle structure for receiving a shaving head of a shaving apparatus, a cleaning fluid container, and a feed device for feeding cleaning fluid from the cleaning fluid container to the cradle structure. The cradle structure is arranged above a fluid level of the cleaning fluid in the cleaning fluid container during the feeding of the cleaning fluid to the cradle structure. The cradle structure is connected to the cleaning fluid container through an overflow device and/or an outlet port.

[0003] In this kind of cleaning device, if a cradle structure is made from, for example, synthetic resin, vibration of a shaving apparatus is transmitted from the cradle structure to the cleaning device in case the shaving apparatus is activated during cleaning in order to enhance a cleaning effect. There is accordingly a problem of a large vibration and sound generated from the cleaning device per se.

WO2004064569 A1 discloses a cleaning device according to the preamble of claim 1.

Summary of Invention

[0004] The present invention has been achieved in view of the above circumstances, and an object thereof is to provide a cleaning device for an electrical appliance, capable of reducing vibration and sound.

[0005] A cleaning device (1) for an electrical appliance of the present invention includes a cleaning bowl (5) for receiving a part needing to be cleaned (Ea) of the electrical appliance (E), a container (7) for storing a cleaning liquid to be fed into the cleaning bowl (5), a cleaning liquid feeder (P) configured to feed the cleaning liquid in the container (7) into the cleaning bowl (5), a discharge passage (C1) for returning the cleaning liquid in the cleaning bowl (5) into the container (7), and a support frame (13) for supporting the cleaning bowl (5). The cleaning bowl (5) has elastic modulus smaller than the support frame (13), and an upper periphery (50) of the cleaning bowl (5) is supported by the support frame (13), and the cleaning bowl (5) is suspended from the support frame (13).

[0006] In an embodiment, the cleaning device (1) further includes a support member (12) for receiving a lower surface of the cleaning bowl.

[0007] In an embodiment, the cleaning bowl (5) includes a watertight connector (56) that is directly connected to the discharge passage (C1, 126).

[0008] In an embodiment, the cleaning bowl (5) includes an overflow outlet (57) for returning cleaning liquid overflowed from the cleaning bowl (5) into the container (7), and an inclined plane (53a) that is led to the overflow outlet (57), and a discharge channel (510). One end of the discharge channel (510) is connected to the inclined plane (53a), and an other end of the discharge channel (510) communicates with an outside of the cleaning device (1).

[0009] In an embodiment, a supported part (50) of the cleaning bowl (5) by the support frame (13) is fixed and made watertight between a member (2) disposed above the cleaning bowl (5) and the support frame (13). The member (2) has elastic modulus larger than the cleaning bowl (5). In an embodiment, the member (2, 22) disposed above the cleaning bowl (5) is in contact with or in the proximity of the cleaning bowl (5, 51) in a horizontal direction. In an embodiment, the member (2, 22) disposed above the cleaning bowl (5) is in contact with the cleaning bowl (5, 51) in a vertical direction.

[0010] In the present invention, since the cleaning bowl has elastic modulus smaller than the support frame for supporting the cleaning bowl, vibration transmitted from the electrical appliance can be reduced even if the electrical appliance is operated during cleaning. Damaging can be prevented when the electrical appliance is attached to the cleaning device.

Brief Description of Drawings

[0011] Preferred embodiments of the invention will now be described in further details. Other features and advantages of the present invention will become better understood with regard to the following detailed description and accompanying drawings where:

FIG. 1 is a cross sectional view of a cleaning device for an electrical appliance with side covers thereof detached, in accordance with an embodiment of the present invention;

FIG. 2 is a perspective view of the cleaning device that receives a part needing to be cleaned of the electrical appliance;

FIG. 3 is a longitudinal sectional view of the embodiment;

FIG. 4 is a perspective view of the cleaning device with a body side thereof lifted;

FIG. 5 is an exploded perspective view of main parts of the cleaning device;

FIG. 6 is an exploded perspective view of main parts of the cleaning device;

FIG. 7 is a sectional view of parts of the cleaning device;

FIG. 8 is an enlarged sectional view of parts of the cleaning device;

FIG. 9 is a perspective view of the cleaning device with a top-face cover, a support mount, the side covers and a front cover detached;

FIG. 10 is a plan view of the cleaning device with the top-face cover and the support mount detached;
 FIG. 11 is a sectional view taken along an N-N line in FIG. 10;
 FIG. 12 is a sectional view taken along an L-L line in FIG. 10;
 FIG. 13 is a side view of a cleaning bowl of the cleaning device;
 FIG. 14 is a plan view of the cleaning bowl;
 FIG. 15 is a perspective view of the cleaning bowl;
 FIG. 16 is an exploded perspective view of a container and a filter frame of the cleaning device;
 FIG. 17 is a perspective view of the container and the filter frame;
 FIG. 18A is a cross sectional view of the container and the filter frame, and FIG. 18B is a longitudinal sectional view of the container and the filter frame; and
 FIGS. 19A to 19D show the filter frame, FIG. 19A is a plan view thereof, FIG. 19B is a back view thereof, FIG. 19C is a side view thereof and FIG. 19D is a bottom view thereof.

Description of Embodiments

[0012] Hereinafter, an embodiment of the present invention is explained in detail with reference to drawings. As shown in FIGS. 1 and 2, a cleaning device 1 is a device for cleaning a part needing to be cleaned (e.g., a blade head Ea) of an electrical appliance (a small electrical appliance) E that is a personal care appliance such as an electric razor (e.g., a reciprocating type electric razor) and the like. The cleaning device 1 is provided at a top face thereof with an opening 20 into which the blade head Ea is inserted with the electrical appliance E made upside down. As shown in FIG. 3, the opening 20 is arranged on a first side in a first direction of the cleaning device 1 (a left side in a crosswise direction in FIG. 3). For example, the first direction defines a front-back direction of the cleaning device 1, and the first side in the first direction defines a front side of the cleaning device 1.

[0013] As shown in FIG. 3, the cleaning device 1 is provided therein with a cleaning bowl 5 (FIG. 6), a container 7 for storing a cleaning liquid (FIGS. 4 and 17), a pump P for circulating the cleaning liquid between the container 7 and the cleaning bowl 5, and a heater unit H and a motor fan F for drying the blade head Ea after it is cleaned (FIGS. 5 and 12). The cleaning device is further provided at an upper back side thereof with a supporting portion S including a connector for electrical connection with the electrical appliance E.

[0014] As shown in FIGS. 3 and 4, the cleaning liquid in the container 7 can be fed into the cleaning bowl 5 through the pump P by setting the container 7 storing the cleaning liquid to the cleaning device 1, electrically connecting the electrical appliance E and the cleaning device 1 through the connector of the supporting portion S while placing the blade head Ea of the electrical appliance E

in the cleaning bowl 5 from the opening 20, and activating the pump P in this state. Specifically, as shown in FIGS. 5 and 9, a base board 12 (a support member) is disposed on an upper opening of the container 7. As shown in FIG. 3, the pump P includes a connecting pipe 126 that protrudes downward from the base board 12 toward an inside of the container 7 and communicates with a side of a bottom of the cleaning bowl 5 and a side of a bottom of the container 7. The cleaning liquid in the container 7 is fed into the cleaning bowl 5 through the connecting pipe 126 of the pump P. The cleaning liquid going over an overflow dam 54 provided in the cleaning bowl 5 is to return into the container 7 located below the cleaning bowl 5. As shown in FIGS. 5, 10 and 17, connecting pipes 127 and 128 protrude downward from the base board 12 toward the inside of the container 7, and the cleaning liquid going over the overflow dam 54 is to return into the container 7 through the connecting pipes 127 and 128. The blade head Ea of the electrical appliance E can be cleaned more quickly and effectively by supplying electric power and transmitting a signal via the aforementioned connector to activate the blade head Ea during cleaning.

[0015] Each component of the cleaning device 1 is explained in detail with reference to FIGS. 5 and 6. The cleaning device 1 is formed of a bottom plate 11, the base board 12 configured to vertically move with respect to the bottom plate 11, a support frame 13 disposed on the base board 12, the cleaning bowl 5 of which periphery of four upper edges is supported by an upper edge of the support frame 13, a top-face cover 2 including the opening 20, a support mount 6 to which the connector is attached, side covers 15 covering sides of the cleaning device, a front cover 16 disposed at a front face of the cleaning device, and the like. In the embodiment, each of the bottom plate 11, the base board 12, the support frame 13, the top-face cover 2, the support mount 6, the side covers 15 and front cover 16 is made from, for example, resin such as ABS (acrylonitrile-butadiene-styrene).

[0016] The bottom plate 11 is provided with guide supports 110 and 110 standing on right and left sides thereof, and the base board 12 is configured to vertically move along the guide supports 110. The guide supports 110 and 110 are provided therein with uplift rods 111 and 111 respectively including springs 112 and 112, which exert an upward force on the base board 12.

[0017] A switch plate 31 is disposed on the base board 12 so as to free to slide from side to side. A spring 32 exerts a force on the switch plate 31 in one direction, and one end of the switch plate 31 is exposed outside from a side cover 15. The switch plate 31 includes engagement parts for engaging with hooks 115 and 115 formed at upper ends of the guide supports 110 and 110. If the switch plate 31 is pressed in while compressing the spring 32, the engagement between the switch plate 31 and the hooks 115 and 115 is released. Accordingly, the base board 12 can move upward by receiving the force which the springs 112 and 112 exert. If the base board 12 is

pressed downward, the switch plate 31 engages with the hooks 115 and 115 again. Accordingly, the base board 12 is kept in the pressed down state.

[0018] As shown in FIGS. 3 and 5, the base board 12 includes a motor cover 120 that is shaped like a cylinder protruding downward, and a motor M is housed in the motor cover 120 through a motor case 121. As shown in FIG. 12 as well, an impeller 123 is attached to an output shaft of the motor, which protrudes downward from a bottom face of the motor cover 120 through an M-shaped seal 122. A pump cover 124 has an opening in central part of a bottom thereof, and is disposed around the impeller 123. When the impeller 123 is rotated, the cleaning liquid sucked from the opening of the pump cover 124 is sent to an inlet and outlet port 56 to be described later in the cleaning bowl 5 through the connecting pipe 126 with which the motor cover 120 is integrally provided. In the embodiment, the motor M, the motor cover 120, the motor case 121, the seal 122, the impeller 123, the pump cover 124 and the connecting pipe 126 constitute the pump P (a cleaning liquid feeder).

[0019] As shown in FIGS. 3 and 5, three liquid level detecting pins 24, 25 and 26 are disposed at an outer side (a back side) of the motor cover 120. The three liquid level detecting pins 24, 25 and 26 to be soaked in the cleaning liquid in the container 7 are adapted to measure a liquid level of the cleaning liquid by electric resistance values between them. That is, the cleaning liquid has electrical conductivity, and accordingly the liquid level is detected based on an electric resistance value between the liquid level detecting pins 24 and 25 and an electric resistance value between the liquid level detecting pins 24 and 26 becoming larger than a prescribed value in the absence of cleaning liquid.

[0020] In the embodiment, a lower end of the liquid level detecting pin 24 is disposed at a lowest position within the liquid level detecting pins 24, 25 and 26, and a lower end of the liquid level detecting pin 25 is different in height from that of the liquid level detecting pin 26. It is accordingly possible to detect liquid level of the cleaning liquid in two stages, for example, a stage in which residual amount of the cleaning liquid is small and a stage in which the residual amount of the cleaning liquid is smaller than an amount that is required for a cleaning operation for circulating the cleaning liquid (cleaning is impossible). In order to secure a detection margin when the cleaning device 1 is put on an inclined plane, the lower end of the liquid level detecting pin 24 is located at a position lower than those of the other two liquid level detecting pins 25 and 26.

[0021] As shown in FIGS. 5, 9 and 15, the cleaning bowl 5 is disposed on the base board 12 through the support frame 13. The cleaning bowl 5 is formed of soft material of which elastic modulus is smaller than that of the support frame 13, for example, rubber. The cleaning bowl 5 includes a folded part 50 (an upper periphery, a supported part) that protrudes sideways from an upper edge of the cleaning bowl 5 and a tip of the folded part

50 is folded downward. As shown in FIG. 8, if the folded part 50 is capped on the upper edge of the support frame 13 and the top-face cover 2 is installed in the cleaning bowl 5, a rib 22 provided on a lower edge of the top-face cover 2 is fit in a groove 51 provided on an end face of the upper edge of the cleaning bowl 5. The upper edge of the cleaning bowl 5 is pressed between the top-face cover 2 and the support frame 13 in a vertical direction, and the rib 22 is in contact with an inner wall of the groove 51 in a horizontal direction, in which waterproof is secured.

[0022] In a case where an upper edge of the cleaning bowl 5 suspended from the support frame 13 is waterproofed only by pressing in the vertical direction, a high accuracy is unnecessary but a force for pressing becomes larger as an area to be waterproofed becomes wider. In a case of the waterproof by contact in the horizontal direction, a large force is unnecessary but positional accuracy in the horizontal direction becomes important. Accordingly, in the embodiment, the waterproof can be easily secured by using both of them.

[0023] As shown in FIGS. 13 to 15, the cleaning bowl 5 includes an overflow dam 54 that divides an inside of the cleaning bowl 5 into two parts (for example, a front cavity and a back cavity). In the embodiment, the cleaning bowl 5 has a cleaning part 52 as the front cavity in front of the overflow dam 54, and an overflow part 53 as the back cavity in back of the overflow dam 54. As shown in FIGS. 3 and 14, the cleaning part 52 is a part for housing the blade head Ea of the electrical appliance E, and determines the position in the front-back direction of the blade head Ea, between a rib 55 integrally provided on a wall surface thereof on a side of the overflow dam 54 and a support part 36 of a head guide 35 disposed on an inner face of the cleaning bowl 5. As shown in FIG. 15, protruded belts 59 are provided on a bottom face of the cleaning bowl 5, and the blade head Ea is supported by the belts 59 with the blade head slightly floated from the bottom face.

[0024] As shown in FIGS. 3, 13 and 14, the cleaning bowl 5 is provided with the inlet and outlet port 56 at a lowest part of the cleaning part 52, and two outlets 57 and 58 in the overflow part 53. As shown in FIGS. 5, 12 and 14, the inlet and outlet port 56 is connected to the pump P through the connecting pipe 126 of the base board 12. Thus, the inlet and outlet port 56 and the pump P (specifically, the connecting pipe 126, the pump cover 124 and the opening of the pump cover 124) constitute a single passage C1. In other words, a feed passage for feeding the cleaning liquid in the container 7 into the cleaning bowl 5 (a passage from the opening to the inlet and outlet port 56) and a discharge passage for discharging the cleaning liquid in the cleaning bowl 5 into the container 7 (a passage from the inlet and outlet port 56 to the opening) constitute the single passage C1. As shown in FIG. 5, a control circuit board 21 and the like constitute a controller that is configured to rotate the impeller 123 in a first rotation direction through the motor

M so that the cleaning liquid in the container 7 flows from the opening of the pump cover 124 to the inlet and outlet port 56 when feeding the cleaning liquid in the container 7 into the cleaning bowl 5.

[0025] As shown in FIGS. 5, 10 and 11, the outlets 57 and 58 are connected to the connecting pipes 127 and 128 of the base board 12, respectively. The connecting pipes 127 and 128 are located just above the container 7 for storing the cleaning liquid. Drainage passing through the outlet 57 is returned into the container 7 through the connecting pipe 127, and drainage passing through the outlet 58 is returned into the container 7 through the connecting pipe 128. As shown in FIGS. 10 and 17, drainage passing through the outlet 57 (the overflow outlet) is returned into the container 7 (a space 7b) via a side of a diversion 82. Drainage passing through the outlet 58 is directly returned into the container 7 (the space 7b). Since the cleaning bowl 5 is formed of rubber, it is possible to easily secure waterproof just by performing direct connection with respect to a connection between the inlet and outlet port 56 (a watertight connector) and the connecting pipe 126 and a connection between the outlets 57 and 58 and the connecting pipes 127 and 128.

[0026] As shown in FIGS. 14 and 15, the outlet 57 has a top opening lower within the two outlets 57 and 58, and carries out discharge for circulating the cleaning liquid. The outlet 58 has a higher top opening and is located at a position farther than the outlet 57 from the overflow dam 54 and is used for emergency in a case where the outlet 57 is clogged up with some cause to lose a function thereof. As shown in FIGS. 7 and 15, a bottom face of the overflow part 53 is shaped into an inclined plane 53a that declines to the outlet 57 at one side. As shown in FIGS. 5 and 14, the overflow dam 54, the overflow part 53, the outlet 57 and the connecting pipe 127 constitute a first overflow passage C2. The overflow dam 54, the overflow part 53, the outlet 58 and the connecting pipe 128 constitute a second overflow passage C3.

[0027] As shown in FIG. 7, a discharge channel 510 is provided adjacent to the overflow part 53. The discharge channel 510 has one end to the inclined plane 53a and the other end communicating with an outside of the cleaning device. The discharge channel 510 is configured to prevent malfunction of internal electronic parts and the like by water immersion by discharging the cleaning liquid outside the cleaning device 1 before the cleaning liquid overflows in the overflow part 53 as a result of the occurrence of clogging.

[0028] As shown in FIGS. 2 and 6, a part surrounded by a wall 500 is shaped like a package and provided at one side in a front edge of the cleaning bowl 5 and used for arrangement of a select button 29 for operation instruction. The select button 29 is exposed from the top-face cover 2 and is configured to drive a switch on a switch board 27 (see FIG. 5) through a switch bar 290 in response to operation thereto. Accordingly, the operation of the cleaning device 1 can be instructed with the select

button 29. At this time, indicator lamps for operation indication provided on the switch board 27 are configured to conduct display in response to the instruction on the top-face cover 2 through a light guide plate 28. The indicator lamps include a lamp for displaying liquid amount in the container 7.

[0029] As shown in FIG. 6, a back cover 23 of the top-face cover 2 and the support mount 6 constitute the supporting portion S. The back cover 23 covers a back side of the support mount 6. The support mount 6 includes contacts 39 on which springs 37 exert individual forward forces through contact supporting members 38. The contacts 39 are exposed on a front face of the support mount 6 without protruding from the front face of the support mount 6.

[0030] A magnet 43 and a yoke 44 for attracting the electrical appliance E are disposed above the contacts 39. As shown in FIG. 3, when the blade head Ea is fit in the cleaning bowl 5, the supporting portion S attracts the electrical appliance E by the magnetic attraction of the magnet 43 to make the contacts 39 come into contact with a terminal Eb of the electrical appliance E. The terminal Eb presses the contacts 39 while compressing the spring 37, thereby securing and keeping a contact pressure. The contact between the contacts 39 and the terminal Eb allows power supply to the electrical appliance E and signal transmission from the cleaning device 1 to the electrical appliance E.

[0031] As shown in FIG. 6, a body sensing plate 42 is disposed in the supporting portion S so as to come into contact with the contacts 39 and configured to be separated from the contacts 39 when the contacts 39 are moved backward as a result of attachment of the electrical appliance E, thereby detecting that the electrical appliance E is attached to the cleaning device 1.

[0032] An air outlet 66 is provided in a lower part of the support mount 6 and the motor fan F is attached at a side of the back thereof. A lower edge of the air outlet 66 is put on an upper edge of a back part of the cleaning bowl 5. As shown in FIG. 12, the motor fan F draws in air from an intake 150 disposed at a back face of the cleaning device 1 and sends the air to the blade head Ea of the electrical appliance E from the air outlet 66. The air outlet 66 for the motor fan F faces diagonally downward so as to send air toward the blade head Ea from upside. Current plates 67 are further provided in order to efficiently change the direction of the air.

[0033] As shown in FIGS. 5 and 12, the heater unit H for heating is installed at a back (a lower surface) side of the cleaning part 52 of the cleaning bowl 5. The heater unit H includes a heater wire, a heater plate, a heater base, a temperature sensor for temperature control and protection component from aberrant heating (not shown). The heater unit H is configured to transmit heat from the heater wire to the blade head Ea through the heater plate, the cleaning bowl 5 and the belts 59 of the cleaning bowl 5 to dry the blade head Ea after cleaning.

[0034] As shown in FIGS. 9 and 12, the cleaning bowl

5 and the top-face cover 2 are installed on the base board 12 through the support frame 13. As shown in FIG. 2, the side covers 15 and the front cover 16 are attached so as to surround parts shown in FIG. 9. Therefore, when the base board 12 is moved in the vertical direction with respect to the bottom plate 11, all components other than the bottom plate 11 and the container 7 detachably placed on the bottom plate 11 are moved in the vertical direction along with the base board 12. The vertical movement allows the container 7 placed on the bottom plate 11 to be detachably attached.

[0035] The container 7 and a filter frame 8 detachably placed in the container 7 are explained with reference to FIGS. 16 to 19. The container 7 placed on the bottom plate 11 has the upper opening and is shaped like a cup of which width at a back side thereof is narrower than that at a front side thereof. A feed-liquid line 70 is formed on an inner wall of the container 7. Protrusions 76 are provided on a lower surface of the container 7. As a result, when the container 7 is put outside the cleaning device 1, the stability of the container 7 can be secured. Even if water drop is adhered to the lower surface of the container 7 by washing or the like, the water drop can be prevented from being adhered to a place where the container 7 is put.

[0036] As shown in FIGS. 16 and 17, the filter frame 8 includes a bottom plate 80 almost covering a bottom face of the container 7, and a partition wall 81 which extends upward from a back part of the bottom plate 80 and of which both side edges are in contact with an inner wall face of the container 7. Projection pieces 74 and 74 for positioning are provided on the inner wall face of the container 7 and determine the position of the filter frame 8. As shown in FIGS. 17, 18A and 18B, an inside of the container 7 is divided by the filter frame 8 into three spaces in total which includes two spaces 7a and 7b partitioned with the partition wall 81, and a space 7c between the bottom face of the container 7 and the bottom plate 80 slightly floated from the bottom face of the container 7. As shown in FIGS. 19A to 19D, the bottom plate 80 includes ribs 85 shaped like a grid on a lower surface thereof, and a recess 88 at part of an upper surface of the back part facing the space 7b. As shown in FIG. 17, when the filter frame 8 is placed in the container 7, a front edge of a periphery thereof is separated by a space from the inner wall face of the container 7.

[0037] As shown in FIGS. 16, 18A and 18B, the diversion 82 is provided at an upper side of the partition wall 81. The diversion 82 includes outlets 84 and 84 provided on an inclined plane 83 that is formed at the upper side of the partition wall 81, and an inclined plane 86 that is just under the outlets 84 and 84 and has an inverse inclination to the inclined plane 83. As shown in FIGS. 16 and 17, a filter 89 is formed of mesh smaller than body hair or the like and is detachably placed on the inclined plane 83 of the diversion 82.

[0038] As shown in FIGS. 17 and 18B, some of the cleaning liquid returned into the partition wall 81 may en-

ter the space 7a partitioned between the partition wall 81 and the inner wall face of the container 7 without passing through the filter 89 and the outlets 84 and 84. The cleaning liquid flows from the space 7a to the space 7b at a side of an upper surface of the bottom plate 80 through the space 7c between the bottom plate 80 and the bottom face of the container 7 and the space (see FIG. 18A) between the front edge of the bottom plate 80 and the inner wall face of the container 7. The cleaning liquid passing through the filter 89 and the outlets 84 enters the space 7b along the inclined plane 86. Opening areas of the outlets 84 are set so that more cleaning liquid passes through the filter 89 and the outlets 84 than the cleaning liquid entering the space 7c through the space 7a without passing therethrough.

[0039] As shown in FIGS. 4 and 5, for cleaning the blade head Ea of the electrical appliance E, cleaning liquid is stored in the container 7 including the filter frame 8 and the container 7 is then placed on the bottom plate 11 with the body side of the cleaning device 1 floated with respect to the bottom plate 11 by operating the switch plate 31. At this time, the container 7 is guided by guide plates 117 and 117 provided on the bottom plate 11 and further positioned by positioning projections 116. The positioning projection 116 is fit into a locking recess 77 (see FIG. 18B) provided in an outer wall face of the container 7, thereby preventing floating of the container 7.

[0040] If the body side of the cleaning device 1 is pushed down, a lower part of the pump P with which the base board 12 is provided is soaked in the cleaning liquid in the container 7. As shown in FIGS. 5, 9 and 19, a packing 17 is attached to an outer part of a lower surface of the base board 12 by an attachment frame 18, and is held between the lower surface of the base board 12 and a flange 72 that protrudes sideways from an upper edge of the container 7. Therefore, the part is waterproofed.

[0041] As stated above, after the container 7 storing the cleaning liquid is set in the cleaning device 1, if the blade head Ea of the electrical appliance E is housed in the cleaning bowl 5 from the opening 20 thereof, the terminal Eb of the electrical appliance E comes into contact with the contacts 39 of the supporting portion S.

[0042] If cleaning is then started by operating the select button 29 of the cleaning device 1 connected to an external power supply, the pump P is activated to feed the cleaning liquid in the container 7 into the cleaning part 52 of the cleaning bowl 5 through the connecting pipe 126 and the inlet and outlet port 56. The cleaning liquid going over the overflow dam 54 of the cleaning bowl 5 is returned into the container 7 through the outlet 57 and the connecting pipe 127. Therefore, the cleaning liquid circulates between the container 7 and the cleaning bowl 5.

[0043] For the cleaning, it is preferable that blades in the blade head Ea of the electrical appliance E be driven through the supporting portion S. The blade head Ea can be cleaned effectively and quickly. In addition, since the cleaning bowl 5 is made of rubber having small elastic

modulus and supported in suspension, vibration and sound are reduced even if the blades of the blade head Ea are driven because vibration of the blade head Ea is hardly transmitted to outer shells and the like of the cleaning device 1. The base board 12 receives a lower surface of the cleaning bowl 5 through the heater unit H, and it is accordingly possible to prevent excessive deformation of the cleaning bowl 5.

[0044] The cleaning liquid in the cleaning bowl 5 goes over the overflow dam 54 and then enters the overflow part 53 to return into the container 7 through the outlet 57 and the connecting pipe 127. The connecting pipe 127 is located just above the filter 89 disposed in the space 7a in the container 7. Therefore, the cleaning liquid with body hair or the like enters the space 7c in a bottom part of the container 7 while flowing through the space 7a along with part of the cleaning liquid without passing through the filter 89. The cleaning liquid without body hair or the like by passing through the filter 89 and the outlets 84 flows to a side of the recess 88 in the space 7b via the inclined plane 86. The opening of the pump P is located at the side of the recess 88, and accordingly the cleaning liquid is again fed into the cleaning bowl 5 through the pump P.

[0045] On the other hand, if body hair and the cleaning liquid enter the space 7c between the lower surface of the filter frame 8 and the bottom face of the container 7 from the space 7a located at one side of a back part of the container 7, they spread along the bottom face of the container 7 and flow into the space 7b from the space between the front edge of the bottom plate 80 of the filter frame 8 and the inner wall face of a front part of the container 7. In this case, the cleaning liquid entering the space 7c spreads as mentioned above and the cleaning liquid fed into the cleaning bowl 5 through the pump P is mainly cleaning liquid without body hair and the like after passing through the filter 89 and the outlets 84. A flow rate of the cleaning liquid passing through the space 7c is considerably small and a flow velocity thereof is also considerably low. Moreover, retention occurs at many places in ribs 85 that are shaped like a grid and disposed on the lower surface of the bottom plate 80 of the filter frame 8. Accordingly, body hair and the like included in the cleaning liquid are deposited and accumulated in the space 7c.

[0046] The cleaning liquid passing through the space 7c flows through a side of the front part of the container 7 and above the bottom plate 80 of the filter frame 8 to reach the recess 88 facing the opening of the pump P on a side of the back part of the container 7. Moreover, the bottom plate 80 intervenes between the deposited and accumulated body hair and the like and the opening of the pump P. Accordingly, the body hair and the like are hardly returned into the cleaning bowl 5 after the pump P sucks them again.

[0047] The space 7c may have a capacity for securing accumulation amount of body hair corresponding to about 10s cleaning operations. If taking the container 7

out from the cleaning device 1 and detaching the filter frame 8 therefrom, a user can wash away the accumulated body hair, and then store new cleaning liquid therein to recover initial cleaning capability. The flange 72 is provided at the upper edge of the container 7 and formed to protrude sideways. It is accordingly possible to smoothly discharge the cleaning liquid (and body hair and the like) with a side of the opening of the container 7 down in order to discard the cleaning liquid in the container 7. The flange 72 is provided for securing hardness for water stop, but the flange 72 is unnecessary in a case where the hardness can be secured by a thickness of a side wall of the container 7.

[0048] If the pump P is stopped after the cleaning is finished, the cleaning liquid in the cleaning part 52 of the cleaning bowl 5 is returned into the container 7 by natural drop from the inlet and outlet port 56 via the connecting pipe 126 and the pump P (a space between the impeller 123 and the pump cover 124). The impeller 123 is soaked in the cleaning liquid in the container 7 and body hair and the like are hardly included in the cleaning liquid in the cleaning part 52 after the cleaning is finished. Therefore, clogging hardly occurs even if the cleaning liquid passes through the pump P. Even if the outlet 57 in the overflow part 53 is clogged during cleaning operation, the cleaning liquid can be prevented from overflowing from the cleaning bowl 5 because another outlet 58 is provided.

[0049] At a point in time the cleaning liquid is collected into the container 7 after the cleaning is finished, the motor fan F and a heater of the heater unit H are energized and then the blade head Ea is dried.

Claims

1. A cleaning device (1) for an electrical appliance (E), comprising
 - a cleaning bowl (5) for receiving a part (Ea), needing to be cleaned, of the electrical appliance (E),
 - a container (7) for storing a cleaning liquid to be fed into the cleaning bowl (5),
 - a cleaning liquid feeder (P) configured to feed the cleaning liquid in the container (7) into the cleaning bowl (5),
 - a discharge passage (C1) for returning the cleaning liquid in the cleaning bowl (5) into the container (7), and
 - a support frame (13) for supporting the cleaning bowl (5),

characterized in that

 - the cleaning bowl (5) has elastic modulus smaller than the support frame (13),
 - an upper periphery of the cleaning bowl (5) is supported by the support frame (13), and the cleaning bowl (5) is suspended from the support frame (13).
2. The cleaning device (1) for the electrical appliance (E), of claim 1, further comprising a support member

- (12) for receiving a lower surface of the cleaning bowl (5).
3. The cleaning device (1) for the electrical appliance (E), of claim 1 or 2, wherein the cleaning bowl (5) comprises a watertight connector (56) that is directly connected to the discharge passage (C1).
 4. The cleaning device (1) for the electrical appliance (E), of any one of claims 1 to 3, wherein the cleaning bowl (5) comprises an overflow outlet (57) for returning cleaning liquid overflowed from the cleaning bowl (5) into the container (7), an inclined plane (53a) that is led to the overflow outlet (57), and a discharge channel (510), and one end of the discharge channel (510) is connected to the inclined plane (53a), and an other end of the discharge channel (510) communicates with an outside of the cleaning device (1).
 5. The cleaning device (1) for the electrical appliance (E), of any one of claims 1 to 4, wherein the cleaning bowl (5) includes a folded part (50) that protrudes sideways from an upper edge of the cleaning bowl (5), if the folded part (50) is capped on the upper edge of the support frame (13) and a top-face cover (2) is installed in the cleaning bowl (5), a rib (22) provided on a lower edge of the top-face cover (2) is fit in a groove (51) provided on an end face of the upper edge of the cleaning bowl (5), elastic module of the cleaning bowl (5) is smaller than that of the support frame (13).
 6. The cleaning device (1) for the electrical appliance (E), of claim 5, wherein the rib (22) is in contact with an inner wall of the groove (51) in a horizontal direction, in which waterproof is secured.
 7. The cleaning device (1) for the electrical appliance (E), of claim 5 or 6, wherein the upper edge of the cleaning bowl (5) is pressed between the top-face cover (2) and the support frame (13) in a vertical direction.
- Patentansprüche**
1. Reinigungsvorrichtung (1) für ein elektrisches Gerät (E), umfassend eine Reinigungsschale (5) zum Aufnehmen eines Teils (Ea), das gereinigt werden muss, des elektrischen Geräts (E), einen Behälter (7) zum Speichern einer Reinigungsflüssigkeit, die in die Reinigungsschale (5) eingeleitet werden soll, eine Reinigungsflüssigkeitszuführung (P), die dazu ausgelegt ist, die Reinigungsflüssigkeit in dem Behälter (7) in die Reinigungsschale (5) zu leiten, einen Auslasskanal (C1) zum Zurückführen der Reinigungsflüssigkeit in der Reinigungsschale (5) in den Behälter (7), und einen Stützrahmen (13) zum Halten der Reinigungsschale (5), **dadurch gekennzeichnet, dass** die Reinigungsschale (5) einen kleineren Elastizitätsmodul als der Stützrahmen (13) aufweist, ein oberer Rand der Reinigungsschale (5) von dem Stützrahmen (13) getragen wird, und die Reinigungsschale (5) an dem Stützrahmen (13) aufgehängt ist.
 2. Reinigungsvorrichtung (1) für das elektrische Gerät (E) nach Anspruch 1, des Weiteren umfassend ein Halteelement (12) zum Aufnehmen einer Unterseite der Reinigungsschale 5.
 3. Reinigungsvorrichtung (1) für das elektrische Gerät (E) nach Anspruch 1 oder 2, wobei die Reinigungsschale (5) einen wasserdichten Verbinder (56) umfasst, der direkt mit dem Auslasskanal (C1) verbunden ist.
 4. Reinigungsvorrichtung (1) für das elektrische Gerät nach einem der Ansprüche 1 bis 3, wobei die Reinigungsschale (5) umfasst einen Überlaufauslass (57) zum Zurückführen von Reinigungsflüssigkeit, die aus der Reinigungsschale (5) übergelaufen ist, in den Behälter (7), eine schiefe Ebene (53a), die zu dem Überlaufauslass (57) führt, und einen Auslasskanal (510), und wobei ein Ende des Auslasskanals (510) mit der schiefen Ebene (53a) verbunden ist, und ein anderes Ende des Auslasskanals (510) mit einer Außenseite der Reinigungsvorrichtung (1) in Verbindung steht.
 5. Reinigungsvorrichtung (1) für das elektrische Gerät nach einem der Ansprüche 1 bis 4, wobei die Reinigungsschale (5) einen gefalteten Teil (50) beinhaltet, der seitlich von einem oberen Rand der Reinigungsschale (5) vorsteht, wenn der gefaltete Teil (50) an dem oberen Rand des Stützrahmens (13) abgedeckt ist und eine oberseitige Abdeckung (2) in der Reinigungsschale (5) installiert ist, eine Rippe (22), die an einem unteren Rand der oberseitigen Abdeckung (2) vorgesehen ist, in eine Nut (51) einrückt, die auf einer Endseite des oberen Randes der Reinigungsschale (5) ausgebildet ist, der Elastizitätsmodul der Reinigungsschale (5) kleiner als derjenige des Stützrahmens (13) ist.

6. Reinigungsvorrichtung (1) für das elektrische Gerät (E) nach Anspruch 5, wobei die Rippe (22) mit einer Innenwand der Nut (51) in einer horizontalen Richtung in Kontakt steht, in der die Wasserdichtigkeit sichergestellt ist.

7. Reinigungsvorrichtung (1) für das elektrische Gerät (E) nach Anspruch 5 oder 6, wobei der obere Rand der Reinigungsschale (5) zwischen der oberseitigen Abdeckung (2) und dem Stützrahmen (13) in einer vertikalen Richtung gepresst wird.

Revendications

1. Dispositif de nettoyage (1) d'appareil électrique (E), comprenant
un bol de nettoyage (5) pour recevoir une pièce (Ea), ayant besoin d'être nettoyée, de l'appareil électrique (E),
un récipient (7) pour stocker un liquide de nettoyage à alimenter dans le bol de nettoyage (5),
un dispositif d'alimentation de liquide de nettoyage (P) configuré pour alimenter le liquide de nettoyage dans le récipient (7) dans le bol de nettoyage (5),
un passage d'évacuation (C1) pour renvoyer le liquide de nettoyage dans le bol de nettoyage (5) dans le récipient (7), et
un cadre de support (13) pour soutenir le bol de nettoyage (5),
caractérisé en ce que
le bol de nettoyage (5) présente un module élastique inférieur au cadre de support (13),
une périphérie supérieure du bol de nettoyage (5) est supportée par le cadre de support (13), et le bol de nettoyage (5) est placé en suspension depuis le cadre de support (13).

2. Dispositif de nettoyage (1) pour appareil électrique (E), selon la revendication 1, comprenant en outre un élément de support (12) pour recevoir une surface inférieure du bol de nettoyage (5).

3. Dispositif de nettoyage (1) pour appareil électrique (E), selon la revendication 1 ou 2, le bol de nettoyage (5) comprenant un connecteur étanche à l'eau (56) qui est directement relié au passage d'évacuation (C1).

4. Dispositif de nettoyage (1) pour appareil électrique (E), selon l'une quelconque des revendications 1 à 3, où
le bol de nettoyage (5) comprend
un orifice de trop-plein (57) pour renvoyer le liquide de nettoyage qui déborde du bol de nettoyage (5) dans le récipient (7),
un plan incliné (53a) qui est dirigé vers l'orifice de trop-plein (57), et

un canal d'évacuation (510), et
une extrémité du canal d'évacuation (510) est reliée au plan incliné (53a), et une autre extrémité du canal d'évacuation (510) communique avec un extérieur du dispositif de nettoyage (1).

5. Dispositif de nettoyage (1) pour appareil électrique (E), selon l'une quelconque des revendications 1 à 4, dans lequel
le bol de nettoyage (5) comprend une partie pliée (50) qui fait saillie de côté depuis un bord supérieur du bol de nettoyage (5),
si la partie pliée (50) est coiffée sur le bord supérieur du cadre de support (13) et qu'un couvercle de face supérieure (2) est installé dans le bol de nettoyage (5), une nervure (22) disposée sur un bord inférieur du couvercle de face supérieure (2) est ajustée dans une rainure (51) disposée sur une face d'extrémité du bord supérieur du bol de nettoyage (5),
le module élastique du bol de nettoyage (5) est inférieur à celui du cadre de support (13).

6. Dispositif de nettoyage (1) pour appareil électrique (E), selon la revendication 5, la nervure (22) se trouvant en contact avec une paroi interne de la rainure (51) dans un sens horizontal, dans lequel l'étanchéité à l'eau est solidement fixée.

7. Dispositif de nettoyage (1) pour appareil électrique (E), selon la revendication 5 ou 6, dans lequel le bord supérieur du bol de nettoyage (5) est pressé entre le couvercle de face supérieure (2) et le cadre de support (13) dans un sens vertical.

FIG. 1

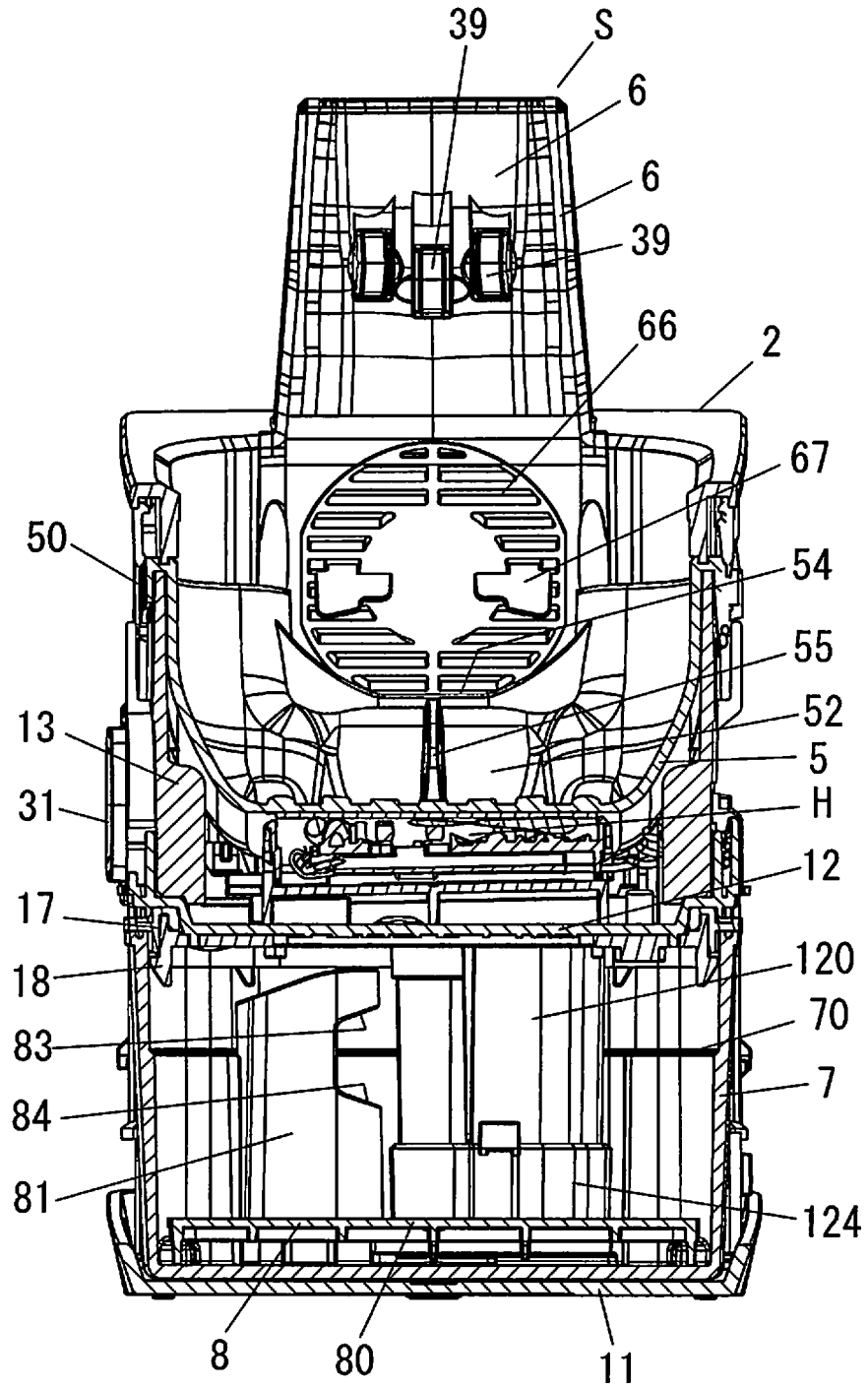

FIG. 2

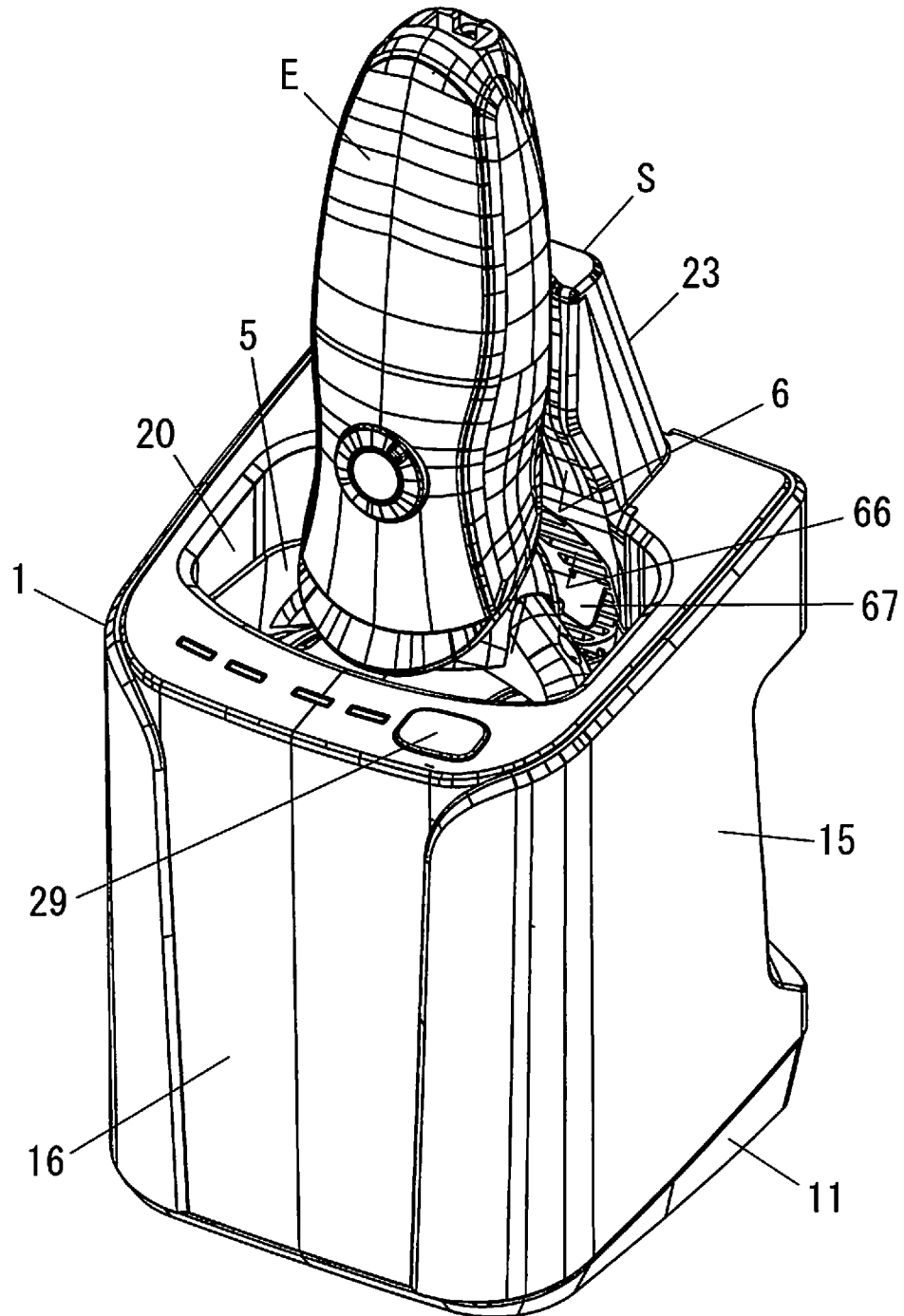

FIG. 3

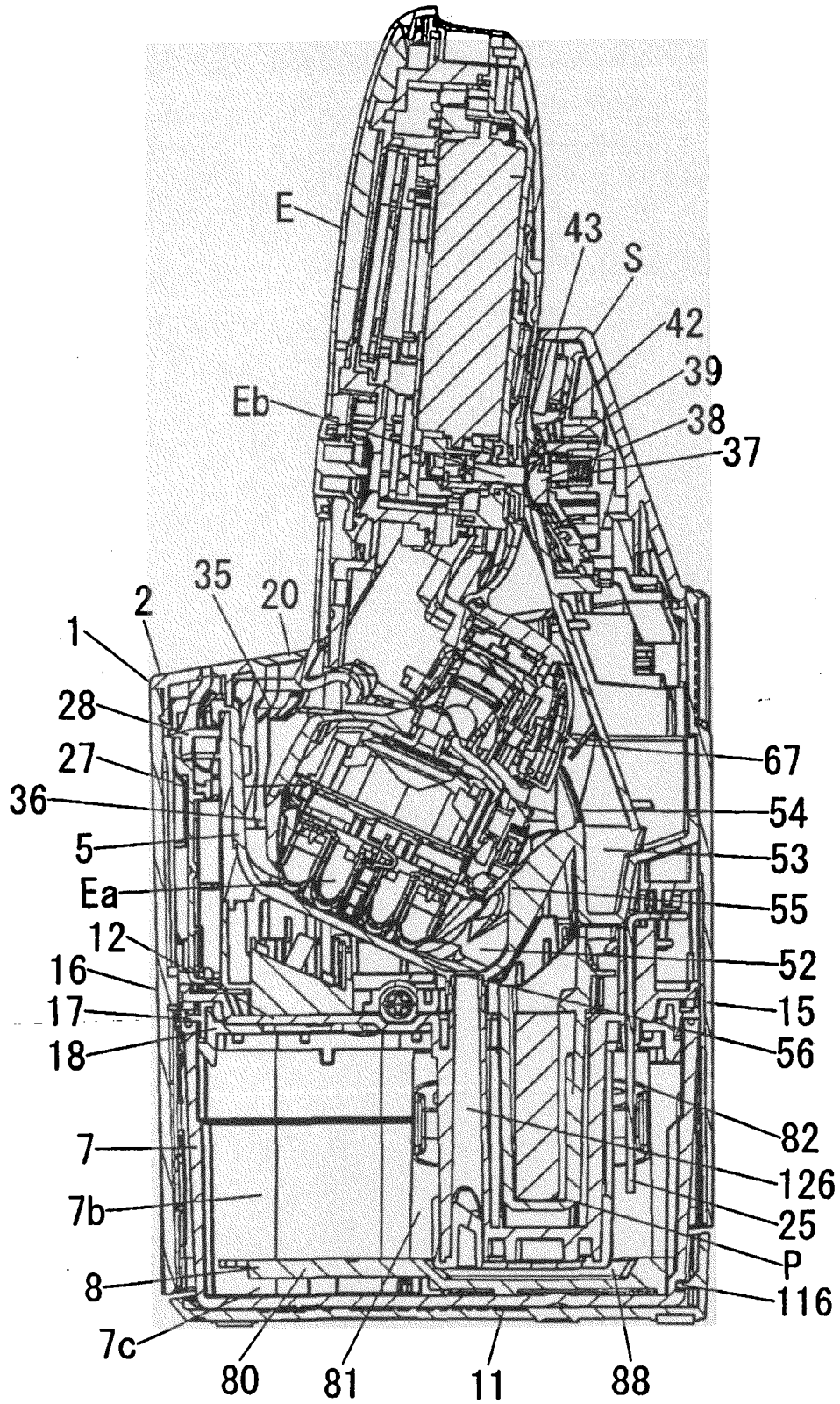

FIG. 4

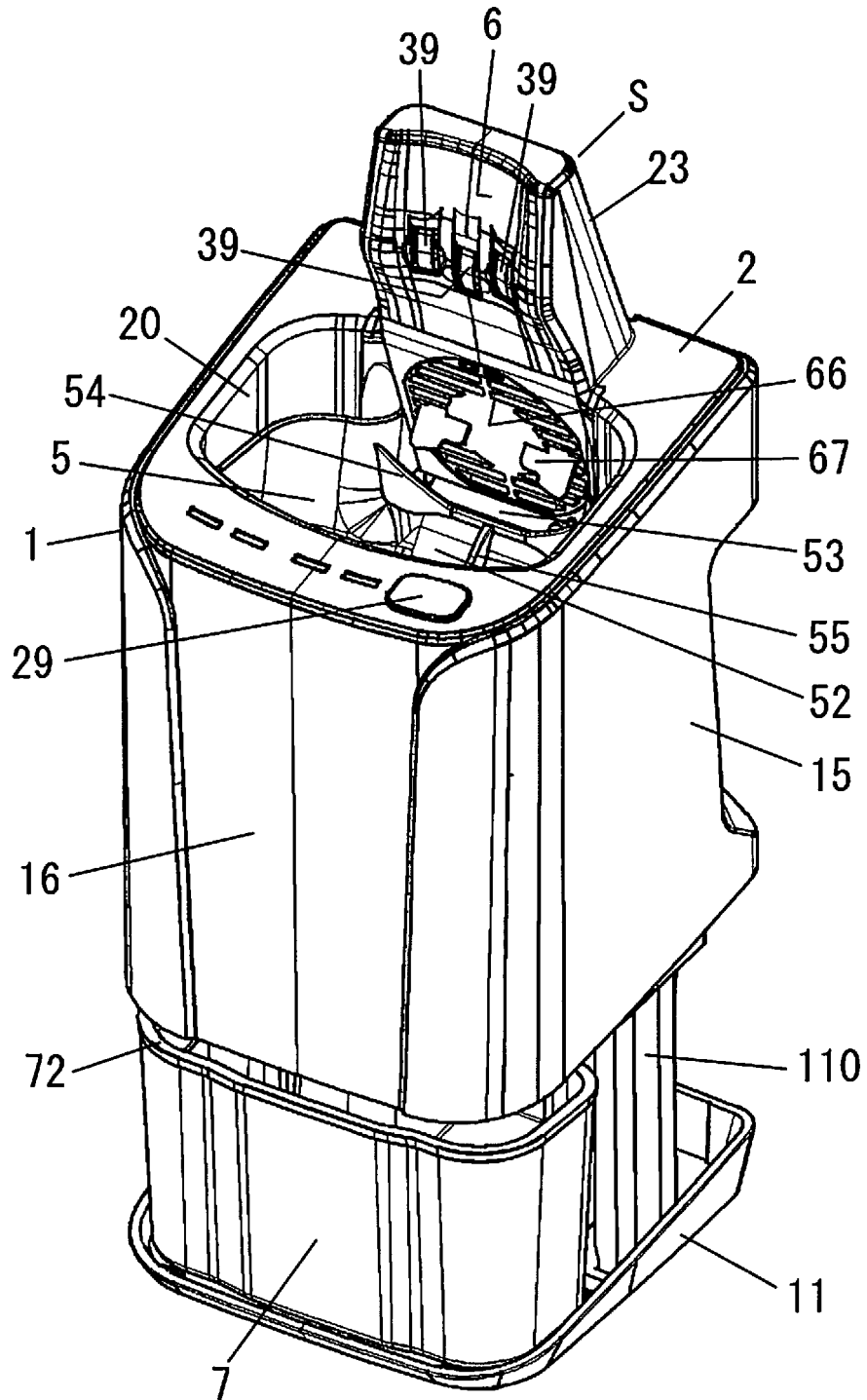

FIG. 5

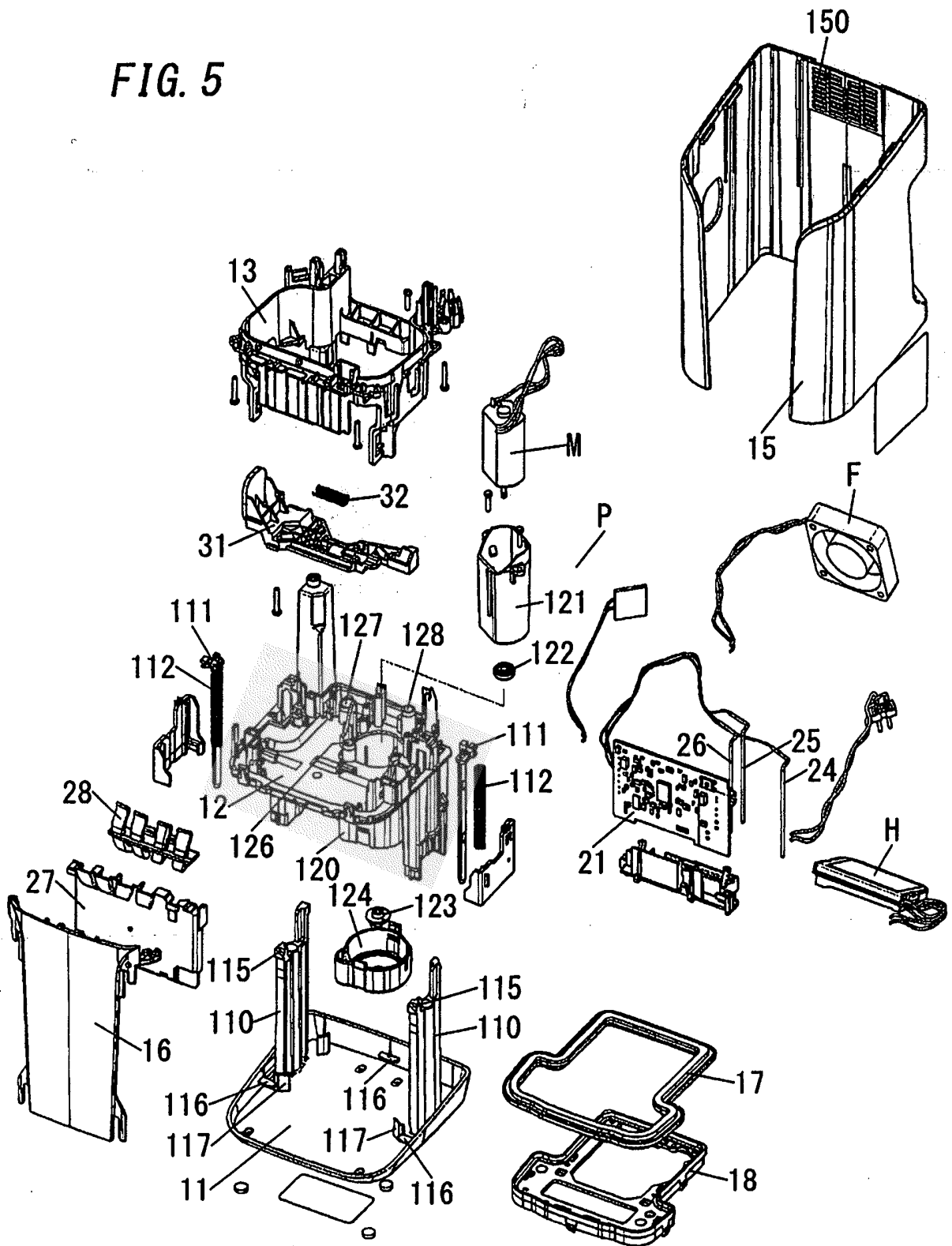

FIG. 6

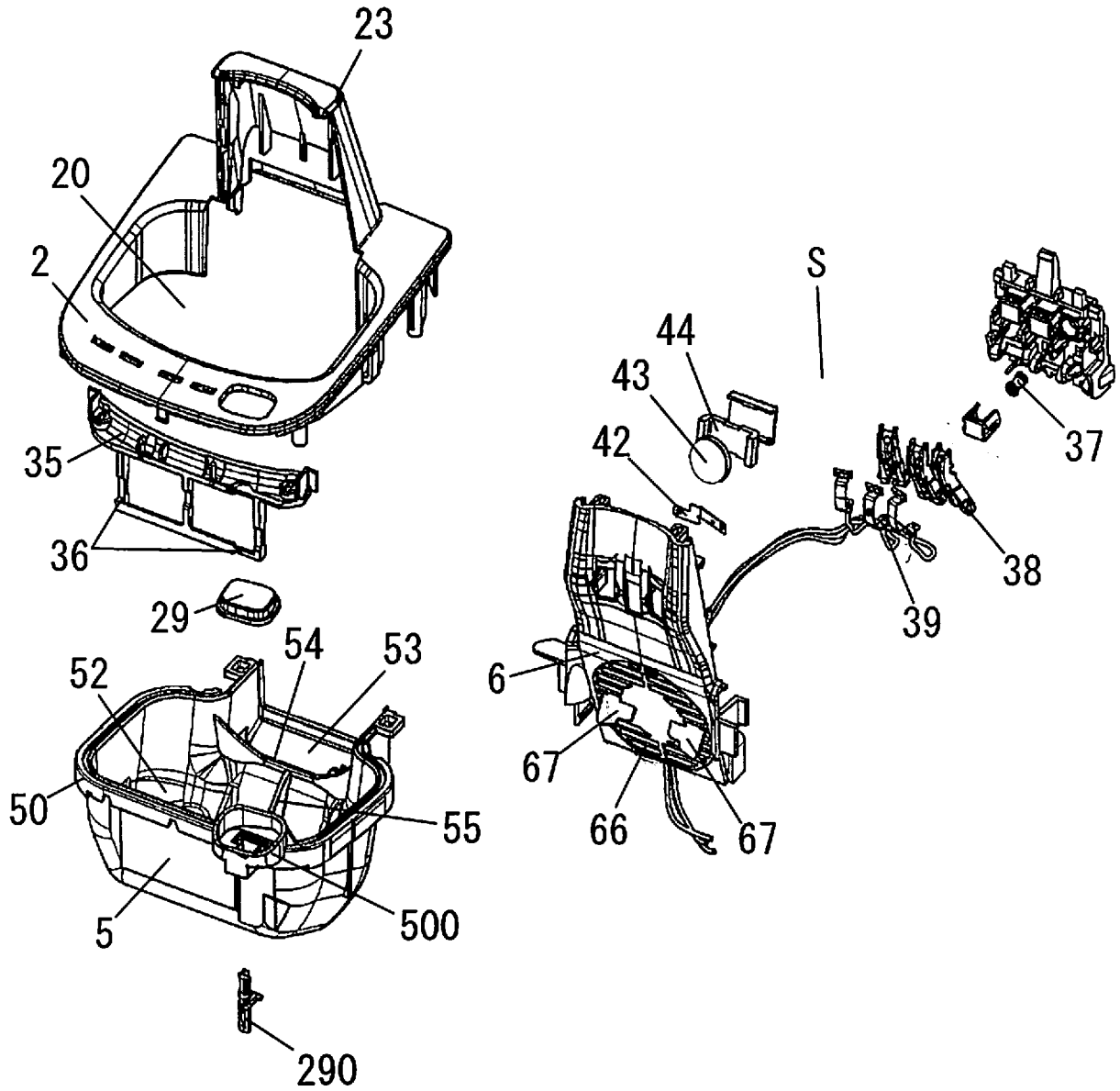

FIG. 7

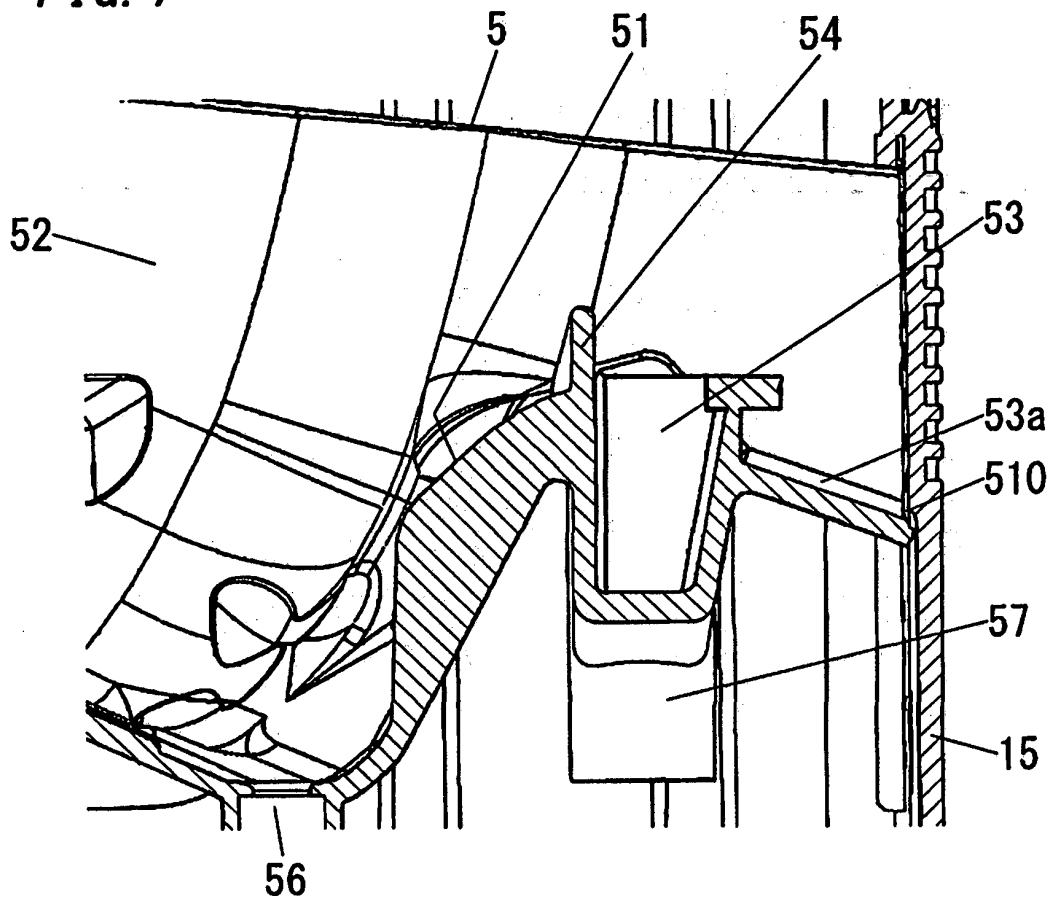

FIG. 8

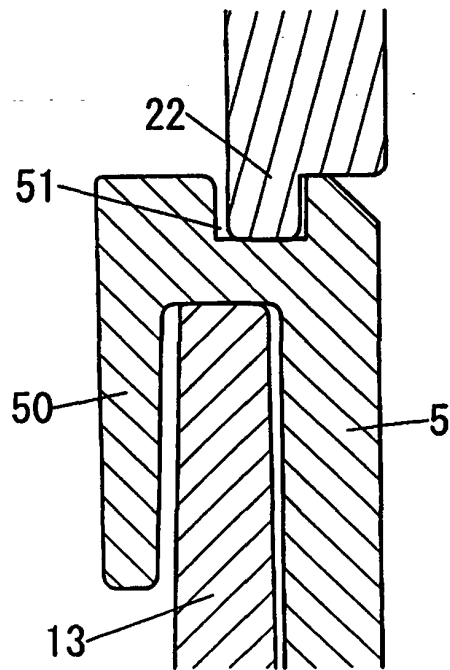

FIG. 9

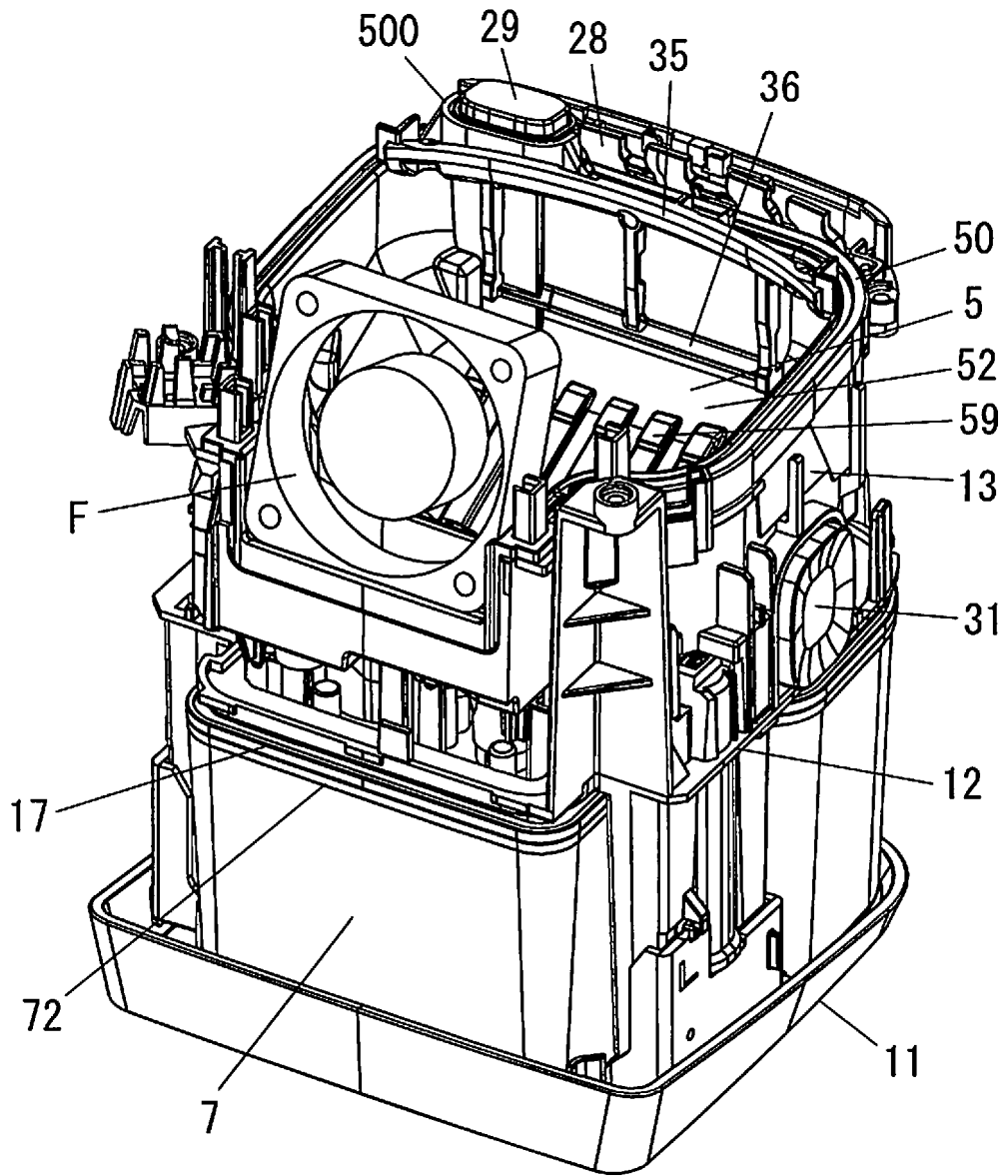

FIG. 10

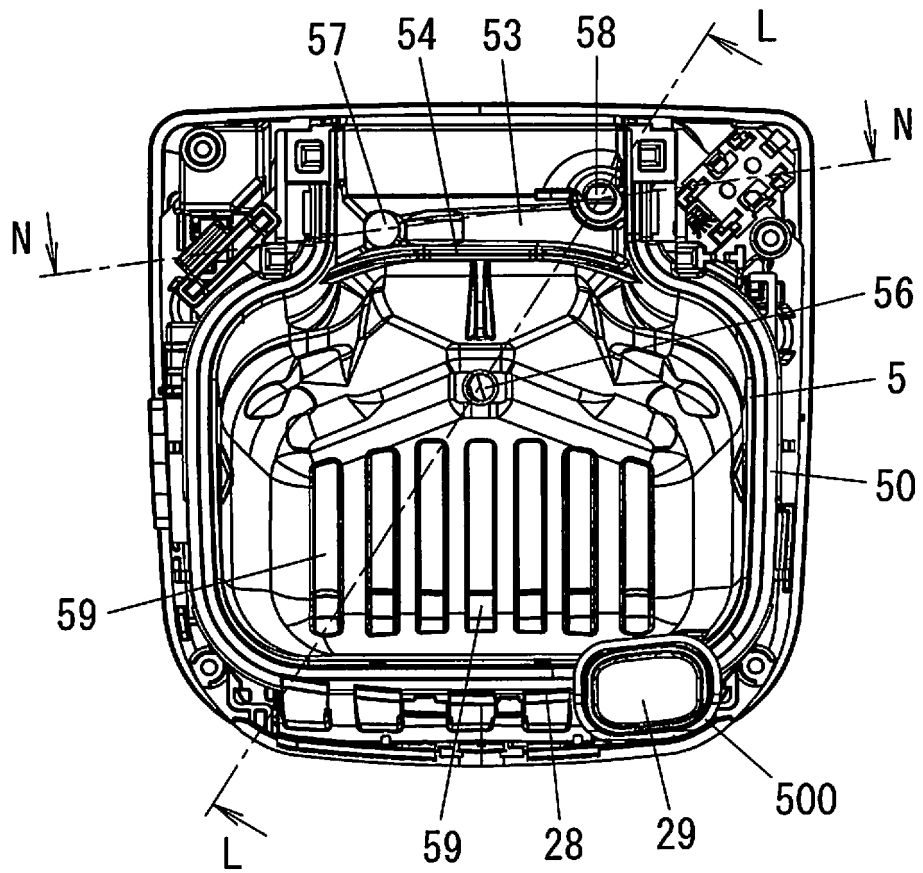

FIG. 11

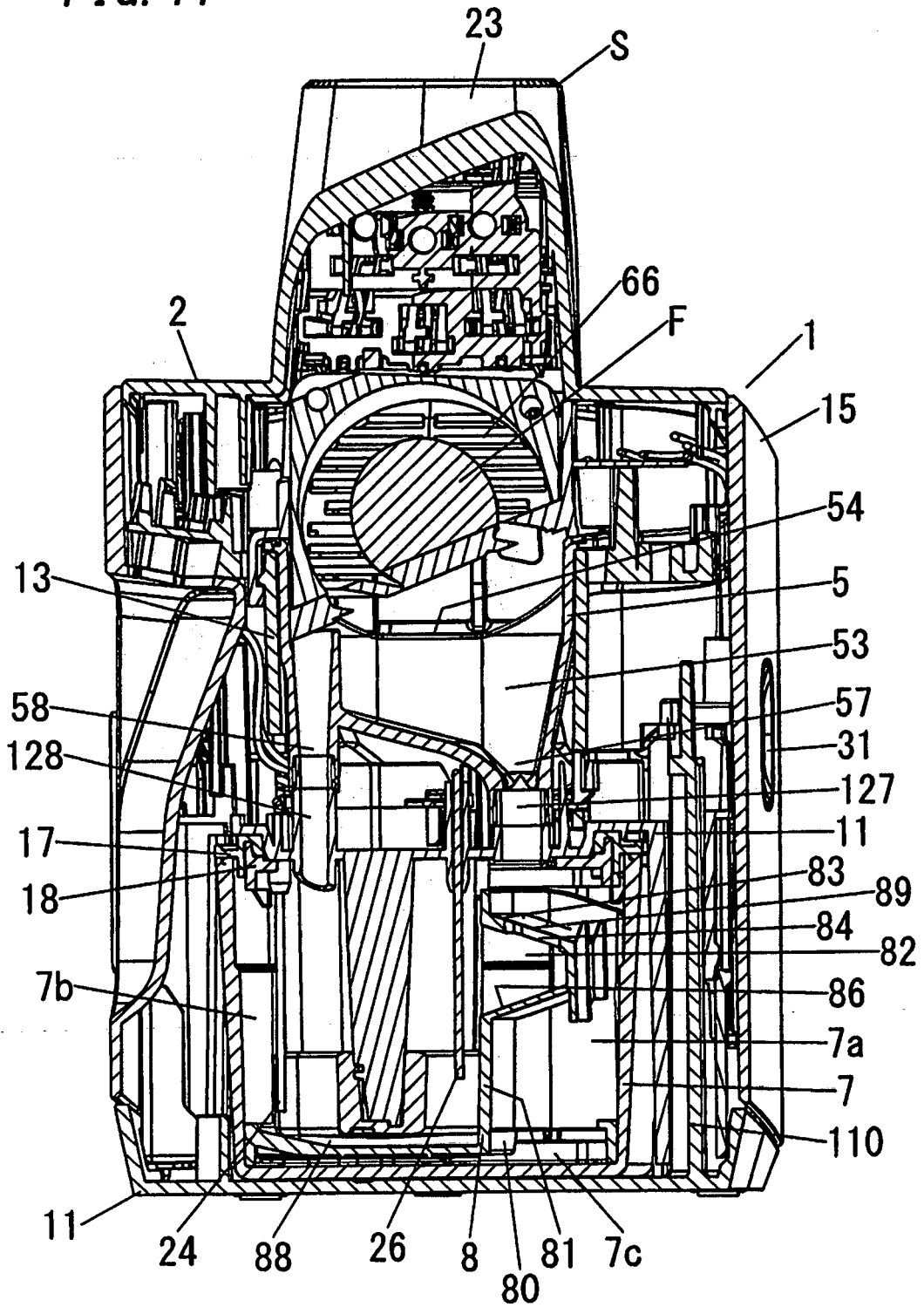

FIG. 12

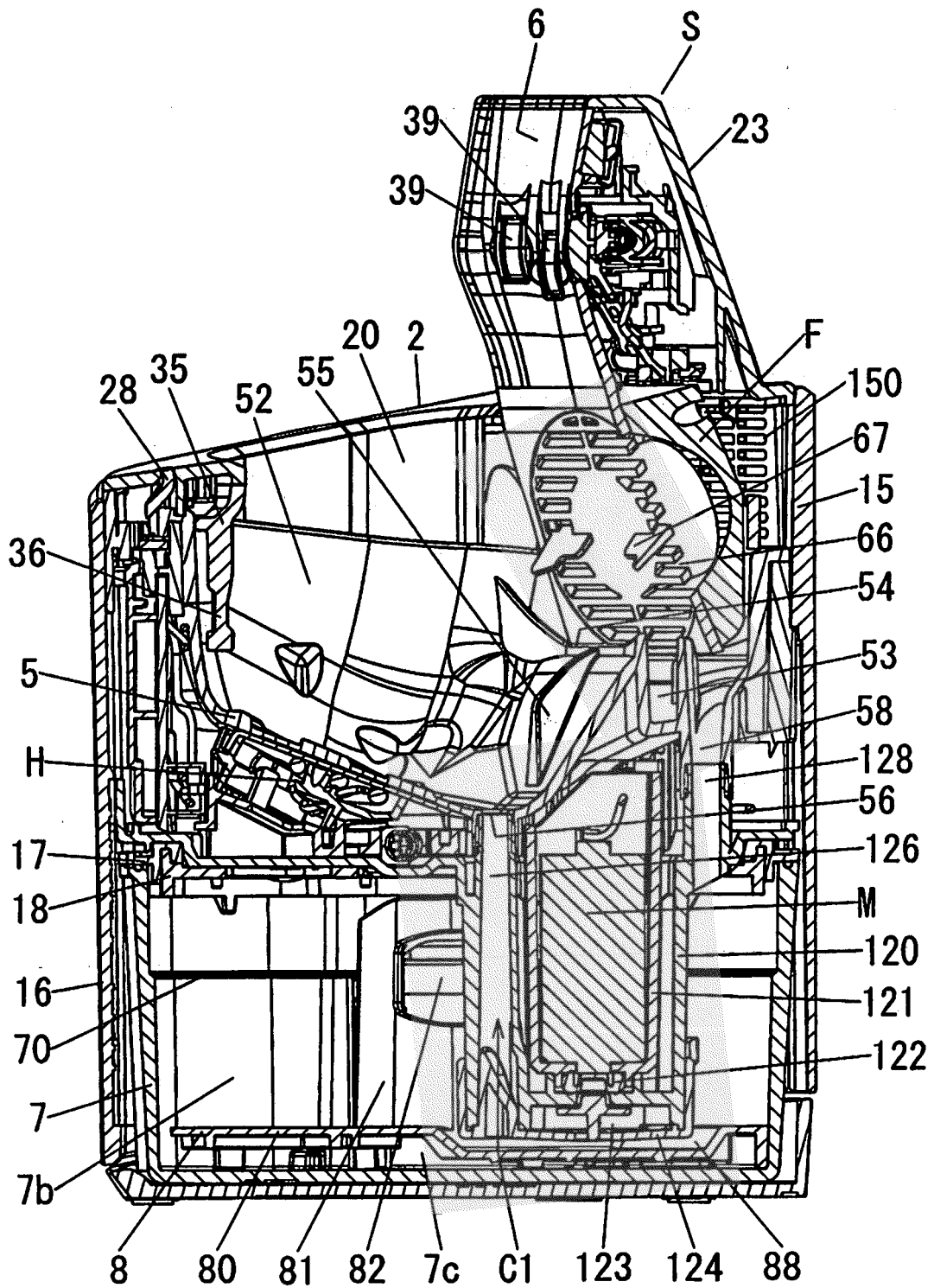

FIG. 13

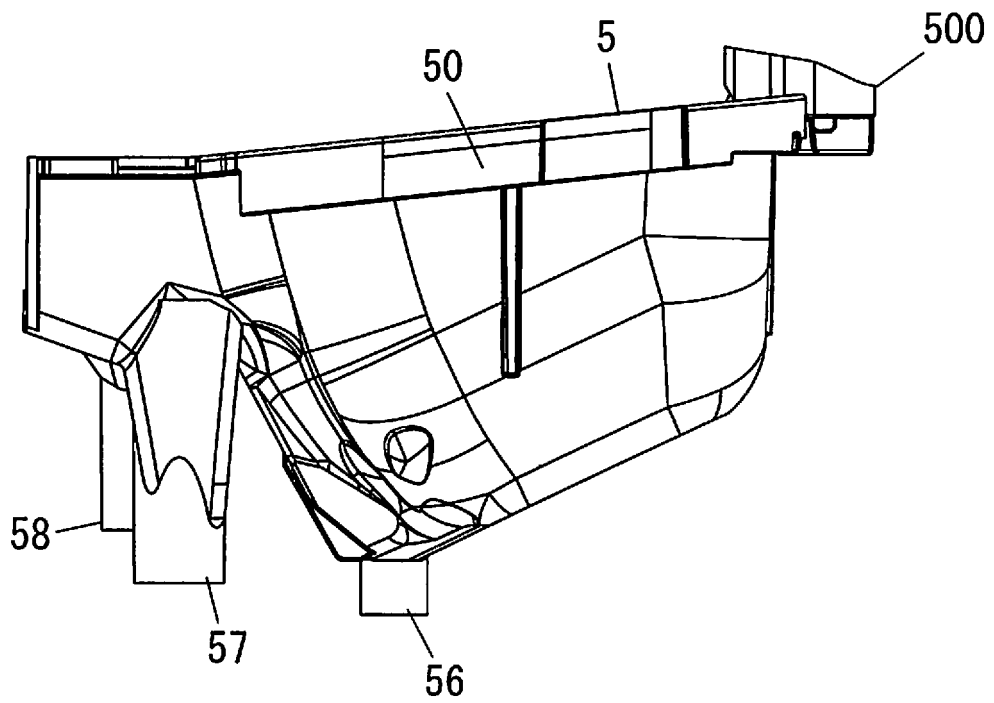

FIG. 14

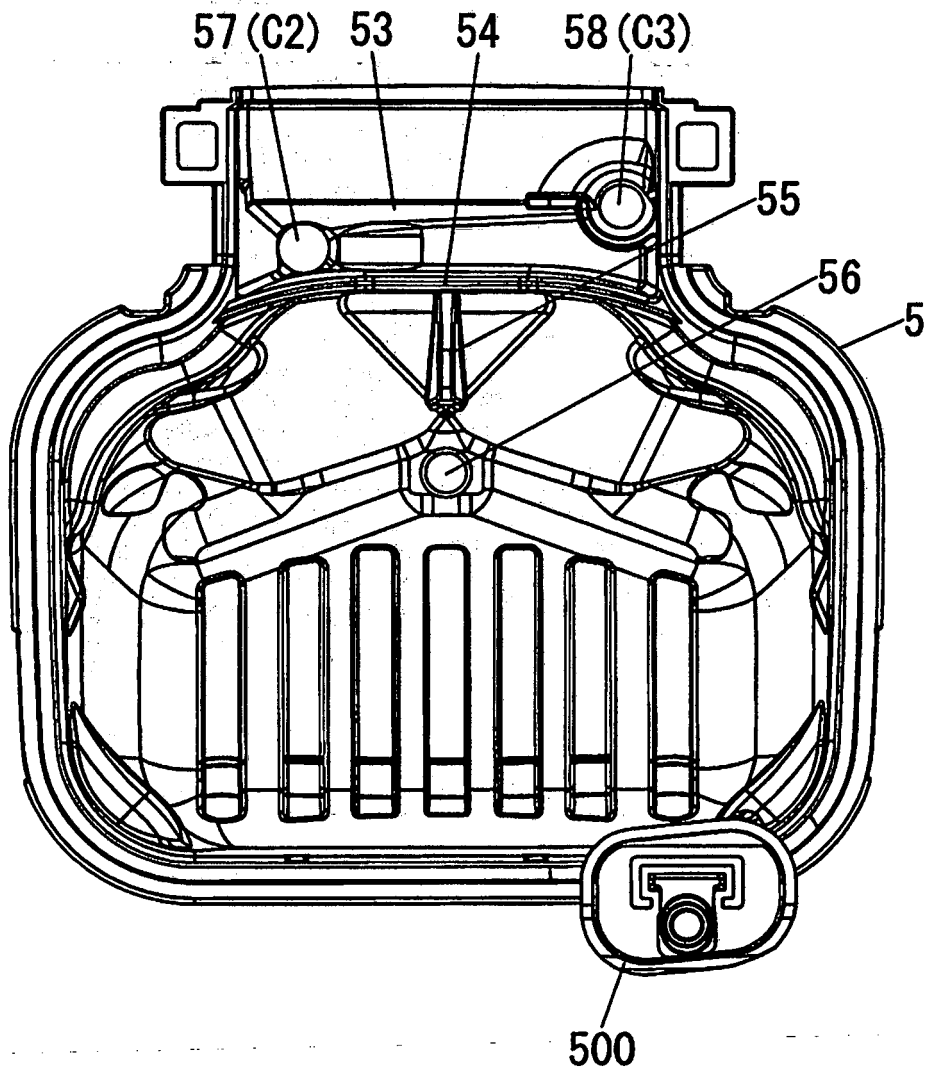

FIG. 15

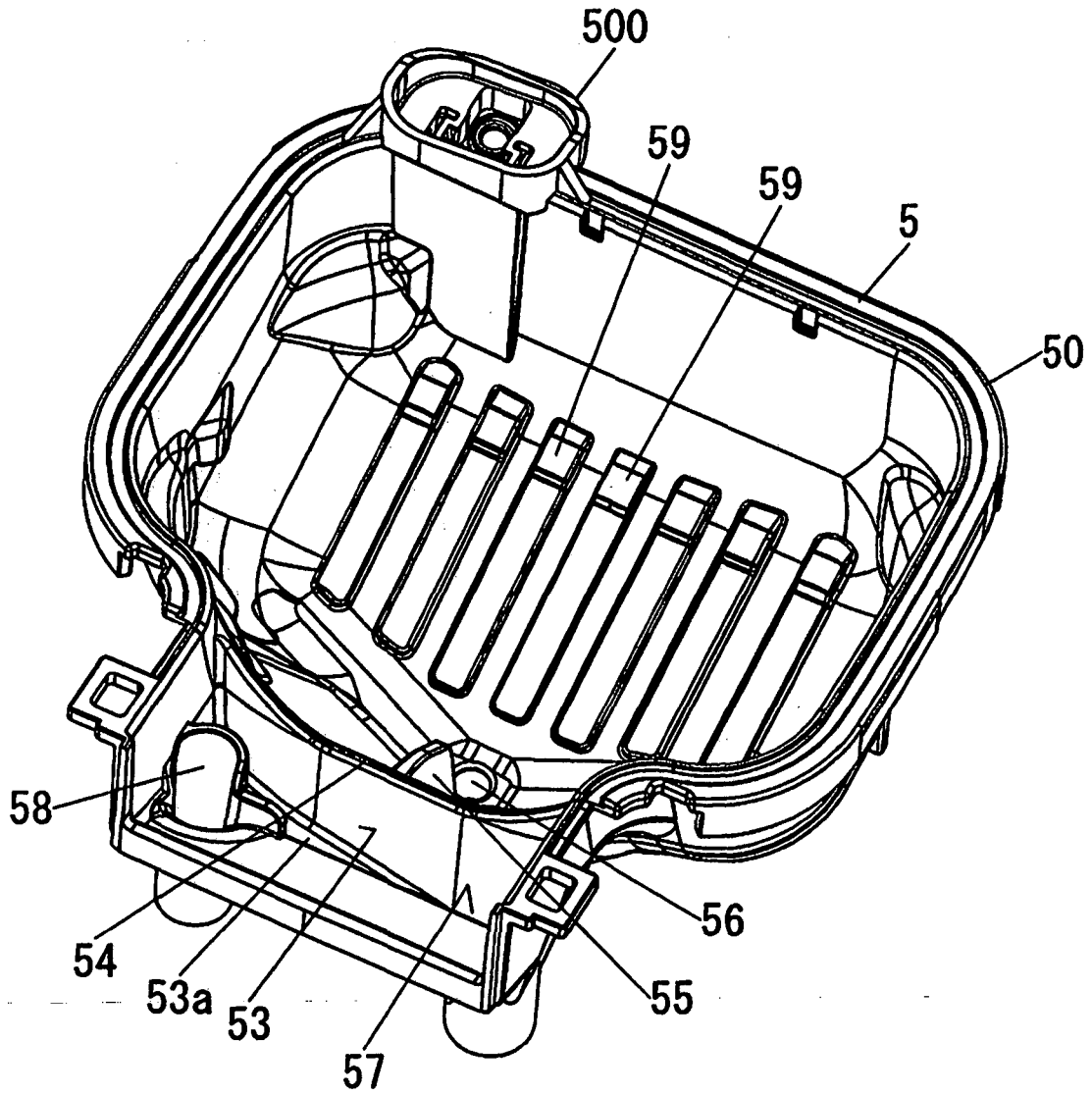

FIG. 16

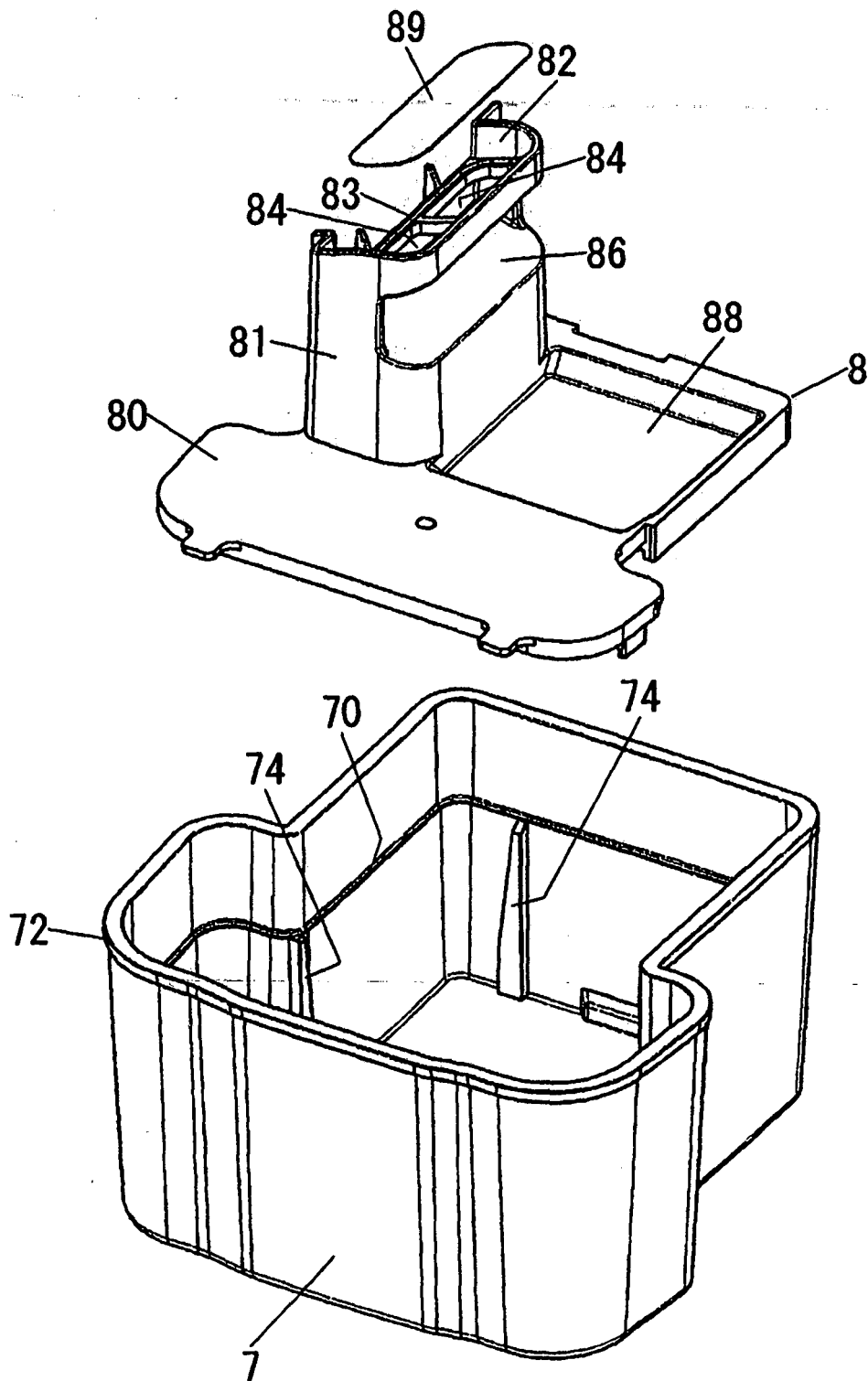

FIG. 17

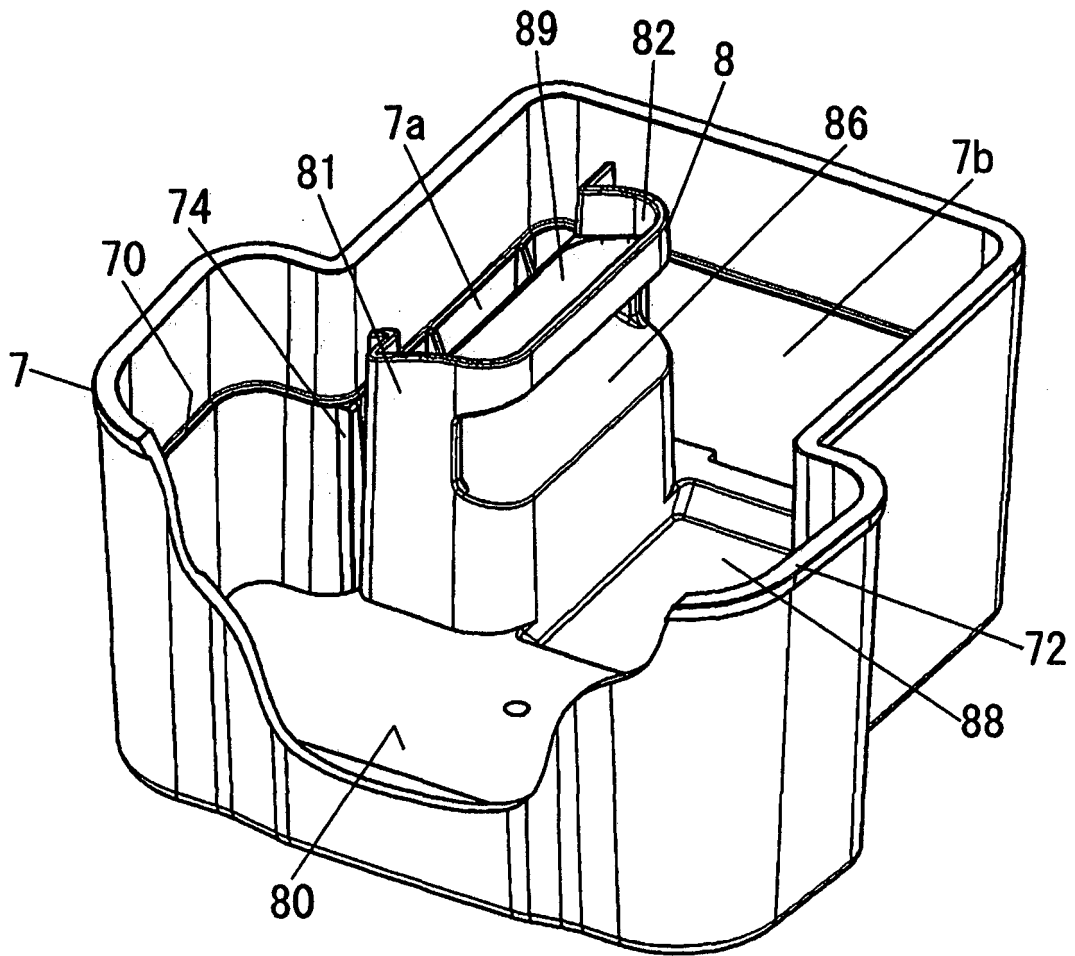

FIG. 18A

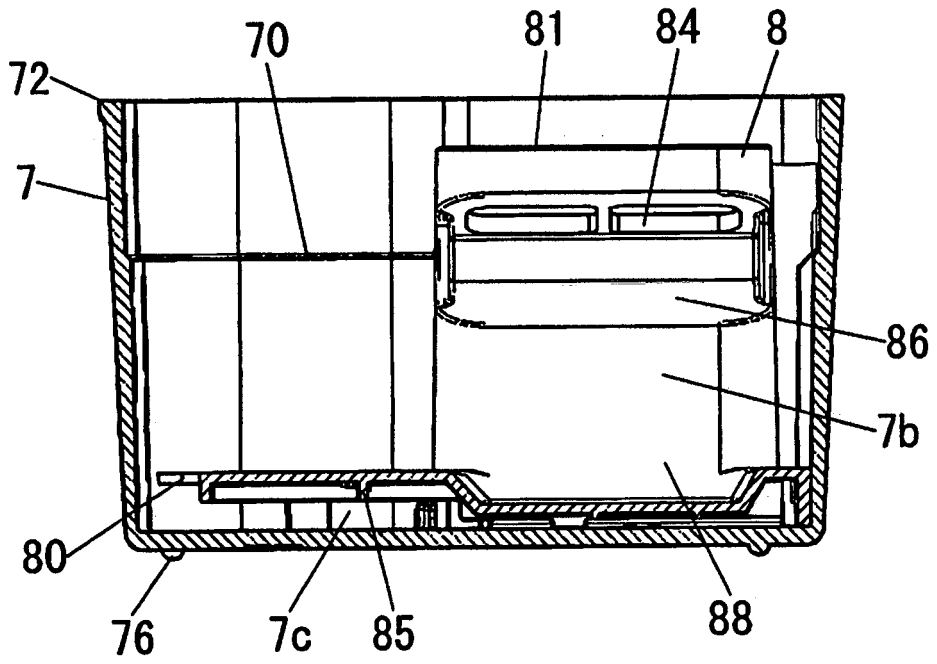

FIG. 18B

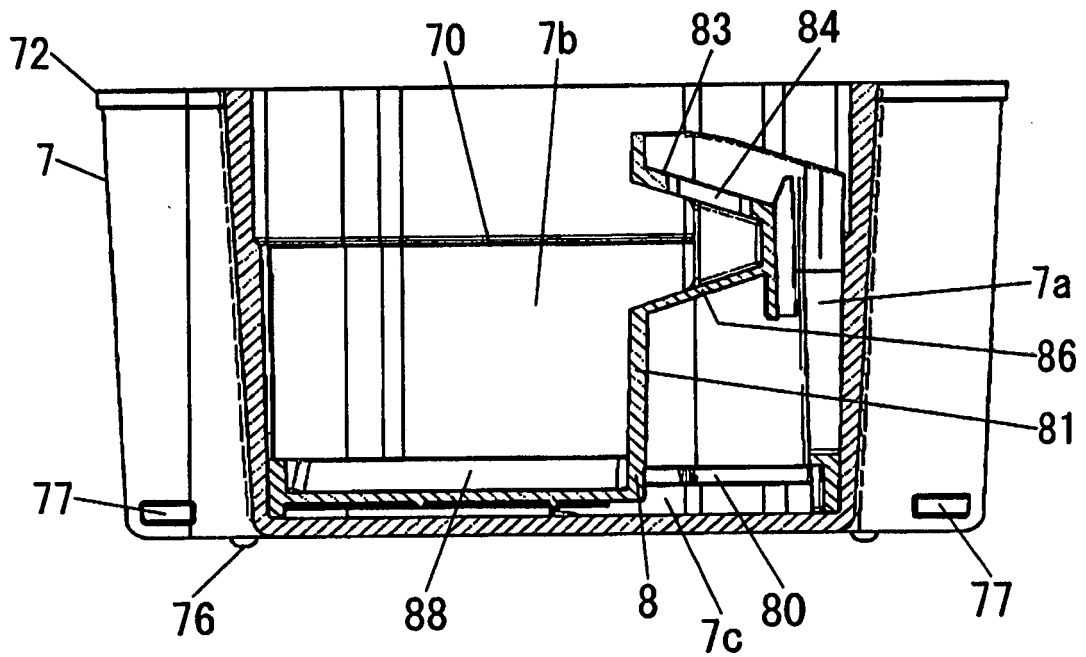

FIG. 19A

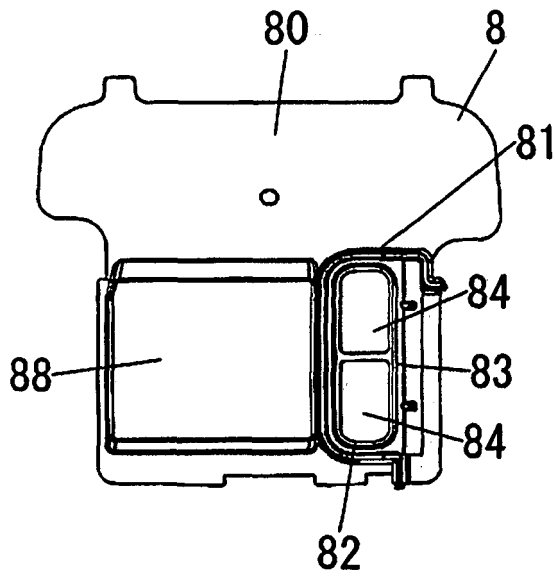

FIG. 19D

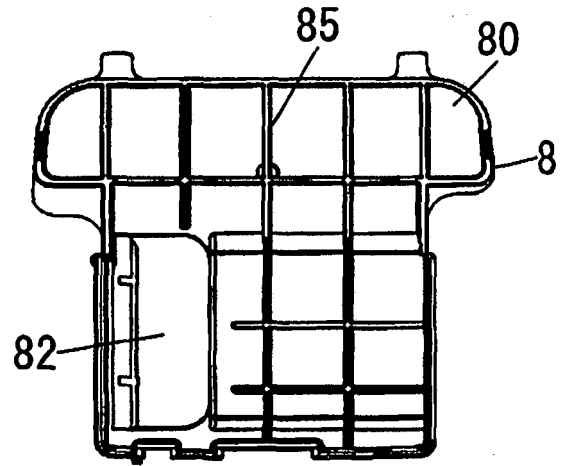

FIG. 19B

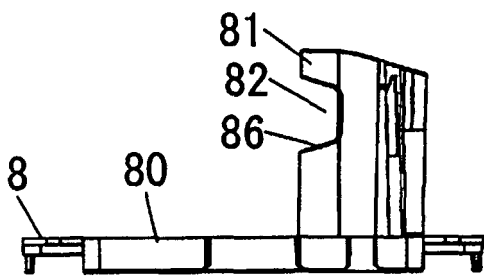
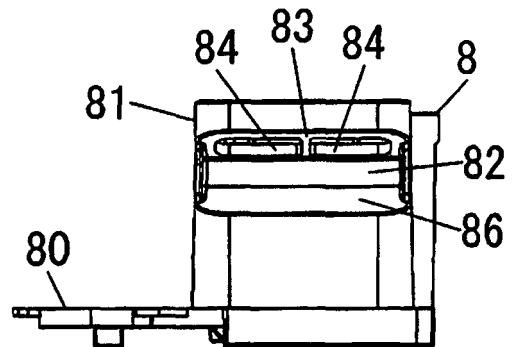

FIG. 19C



REFERENCES CITED IN THE DESCRIPTION

This list of references cited by the applicant is for the reader's convenience only. It does not form part of the European patent document. Even though great care has been taken in compiling the references, errors or omissions cannot be excluded and the EPO disclaims all liability in this regard.

Patent documents cited in the description

- JP 3652393 B [0002]
- US 5711328 A [0002]
- WO 2004064569 A1 [0003]