



(12) **EUROPEAN PATENT APPLICATION**

(43) Date of publication:  
**04.03.2015 Bulletin 2015/10**

(51) Int Cl.:  
**A47C 4/02 (2006.01)**

(21) Application number: **14180860.0**

(22) Date of filing: **13.08.2014**

(84) Designated Contracting States:  
**AL AT BE BG CH CY CZ DE DK EE ES FI FR GB GR HR HU IE IS IT LI LT LU LV MC MK MT NL NO PL PT RO RS SE SI SK SM TR**  
 Designated Extension States:  
**BA ME**

(71) Applicant: **Viteria Pettarini S.r.l.**  
**33044 Manzano UD (IT)**

(72) Inventor: **Pettarini, Agostino**  
**33047 Remanzacco (UD) (IT)**

(74) Representative: **Petraz, Gilberto Luigi et al**  
**GLP S.r.l.**  
**Viale Europa Unita, 171**  
**33100 Udine (IT)**

(30) Priority: **30.08.2013 IT UD20130032 U**

(54) **Furniture item with traction device**

(57) A furnishing element comprises at least two opposite support frames (11, 12) and a traction device (19) interposed and connected between the two frames (11, 12) and comprising an intermediate drive element (22), configured to define a traction condition and reciprocal drawing together of the two frames (11, 12). The traction device (19) comprises attachment segments (30) provided in an opposite position on one side and on the other side with respect to the drive element (22) and each re-

ceivable, in an attached condition, in a corresponding housing seating (31a, 31b) made in the frames (11, 12). Each housing seating (31a, 31b) is internally delimited at least by a holding surface (32a, 32b) interposed, in the attached condition, between the attachment segment (30) and said drive element (22), and in abutment, in the traction condition, with the respective attachment segment (30) inserted in the respective housing seating (31a, 31b).

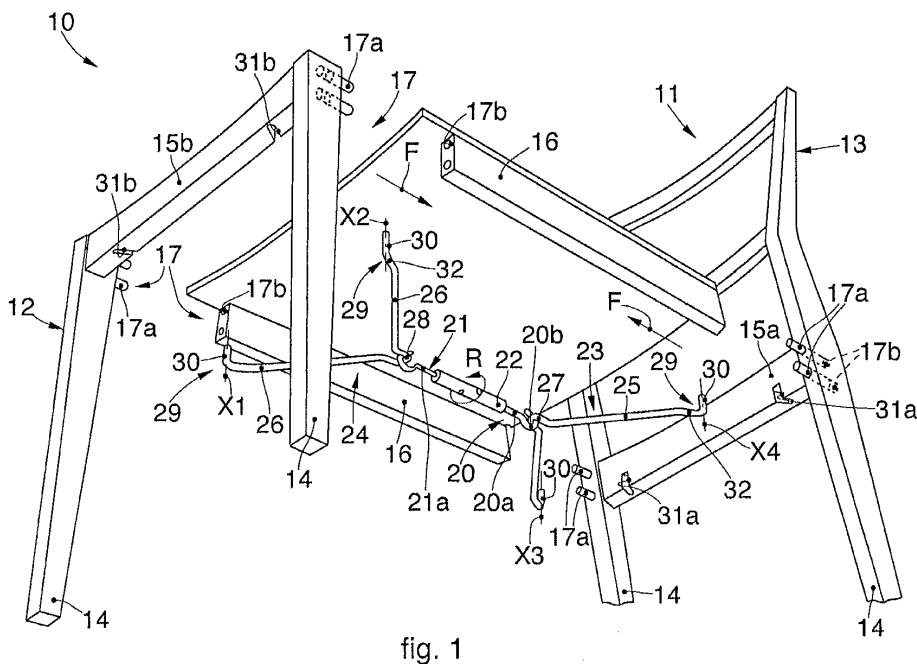

## Description

### FIELD OF THE INVENTION

**[0001]** The present invention concerns a furnishing element of the type provided with legs that support a support or resting plane, such as for example, but not only, a seating element, in particular a chair, or a table and suchlike.

**[0002]** In particular the furnishing element according to the present invention is the type that can be assembled and disassembled, and does not need, for its assembly, normal hardware attachment elements such as screws, bolts and suchlike.

### BACKGROUND OF THE INVENTION

**[0003]** It is known to make furnishing elements of the type which can be assembled and disassembled, among which, for example, seats, stools, sofas, armchairs, tables, desks, benches or other.

**[0004]** Furnishing elements that have a wood frame have their components assembled by means of reciprocal geometric coupling and are attached to each other by means of screws, bolts, or other hardware attachment elements.

**[0005]** One disadvantage of these known furnishing elements is the use of hardware attachment elements, which can be costly and complex.

**[0006]** From this derives the possibility that the attachment elements may loosen over time, with the repeated use of the furnishing element, because of the grip that the hardware has on the wood and the possibility of partial yielding because of the stresses deriving from use. One disadvantage of known attachment elements is that it takes a long time to restore the initial conditions of optimal traction and consequent stability of the furnishing element.

**[0007]** Another disadvantage is the need to use assembly tools that require a particular level of expertise for their use. Related to this, there is the further disadvantage of the long time needed for assembly.

**[0008]** Furnishing elements are known that, although they do not provide to use hardware attachments, require to use at least two telescopic tie-rods put under traction by levers to keep together under traction the various components. These solutions, however, have the disadvantage of needing a high number of auxiliary clamping elements.

**[0009]** Furnishing elements are also known in which a traction device includes two attachment elements acting on opposite frames of the furnishing element and put under traction by means of a common central drive element.

**[0010]** These furnishing elements, although easy to assemble and quick to restore in the event that, following wear, the traction exerted by the traction device is slackened, can have an excessive number of components

needed for assembly, even though this number is reduced compared with the state of the art prior to them.

**[0011]** One purpose of the present invention is to obviate said disadvantages, obtaining a furnishing element that is easy and rapid to assemble, that does not need hardware attachment elements, and that uses a limited number of components, at the same time guaranteeing solidity and overall resistance.

**[0012]** Another purpose of the present invention is to obtain a furnishing element that allows to minimize the operations needed to produce it and that therefore allows a significant reduction in production costs.

**[0013]** Another purpose is to obtain a traction device for a furnishing element that allows an easy, effortless and secure assembly thereof, and confers upon it robustness and safety, and is easy and quick to restore if, over time and with use, there is slackening and partial yielding.

**[0014]** The Applicant has devised, tested and embodied the present invention to overcome the shortcomings of the state of the art and to obtain these and other purposes and advantages.

### SUMMARY OF THE INVENTION

**[0015]** The present invention is set forth and characterized in the independent claim, while the dependent claims describe other characteristics of the invention or variants to the main inventive idea.

**[0016]** In accordance with the above purposes, a furnishing element according to the present invention comprises at least two opposite support frames and a traction device configured to be interposed and connected between the at least two frames. The traction device comprises at least an intermediate drive element, to define a traction condition and obtain a reciprocal drawing together of the at least two frames.

**[0017]** According to a characteristic feature of the present invention, the traction device also comprises a plurality of attachment segments provided in an opposite position on one side and on the other with respect to the drive element. Furthermore, the at least two frames comprise a plurality of housing seatings configured to each receive, in an attached condition, a respective attachment segment. Each of the housing seatings is internally delimited at least by a holding surface configured to be at least partly interposed, in the attached condition, between the attachment segment and the drive element, and to be in abutment, in the traction condition, with the respective attachment segment inserted in the respective housing seating.

**[0018]** In this way, the advantage is obtained of being able to achieve the firm and secure assembly of the furnishing element and to maintain a firm and secure conformation only by inserting the attachment segments into the respective housing seatings and by driving the drive element of the traction device. Furthermore, driving the latter may provide only a rotation with respect to its longitudinal axis and can be performed both to determine

the traction condition at the moment of assembly, and also to restore said condition in the event that the traction were to slacken with use.

**[0019]** The attachment and drive operations mentioned above are obviously simple to perform and can be actuated even by the final user of the furnishing element according to the present invention.

**[0020]** This makes the method to assemble the furnishing element easy, simple and quick; it also has the advantageous consequence that it does not require, except minimally, any pre-assembly steps for the producer, who can therefore contain both times and costs of producing the furnishing element.

**[0021]** Another advantage, due to the fact that the connection between the traction device and the support frames is achieved by means of attachment, is that it is possible to simplify the operations of making the housing seatings and the traction device, thus allowing another reduction in the production times and costs of the furnishing element, and also avoids the need to use attachment means such as screws, bolts, bushings or other hardware material.

**[0022]** According to some features of the present invention, the traction device is configured to exert, in the traction condition and by driving the drive element, a traction force provided along a first lying plane of the traction device and applied transversely to a second lying plane of each of the frames.

**[0023]** In this way, by means of said traction force, it is possible to maintain the frames in their position and to determine a solid attachment of the furnishing element, exploiting the action of the holding surfaces both to bring the frames nearer each other and also to prevent the attachment elements from coming out or the frames from reciprocally separating over time.

**[0024]** In some forms of embodiment, the housing seatings can be made in a single milling operation, which is indicative of the simplification that can advantageously be obtained thanks to the present invention.

**[0025]** In possible solutions according to the present invention, the housing seatings can be made in connection cross-pieces between legs of the frames.

**[0026]** In some forms of embodiment, the housing seatings can be open toward an internal zone comprised between the two frames and/or a zone comprised between two legs of each frame.

**[0027]** This allows to facilitate the final user in assembling the furnishing element, supplying by means of said apertures a convenient and immediate access of the attachment segments in the housing seatings.

**[0028]** According to some aspects of the present invention, the housing seatings can be defined by two portions having different penetration heights inside the respective cross-pieces in which they are made. In particular, in some forms of embodiment, the housing seatings include a first portion, more external, and a second portion, more internal in the thickness of the cross-piece, wherein the second portion has a greater penetration

height than that of the first portion.

**[0029]** The presence of the two portions allows both to facilitate the insertion of the attachment segments into the housing seatings, and also, thanks to the greater depth of the second portion, to achieve a solid anchorage and holding of the attachment segments even in the traction condition.

#### BRIEF DESCRIPTION OF THE DRAWINGS

**[0030]** These and other characteristics of the present invention will become apparent from the following description of a preferential form of embodiment, given as a non-restrictive example with reference to the attached drawings wherein:

- fig. 1 is a perspective view in separate parts of a furnishing element according to the present invention;
- fig. 2 is a plan view of a part of fig. 1;
- fig. 3 is a variant of fig. 2, shown in section from III to III of fig. 2.

#### DETAILED DESCRIPTION OF SOME FORMS OF EMBODIMENT

**[0031]** We shall now refer in detail to the various forms of embodiment of the present invention, of which one or more examples are shown in the attached drawings. Each example is supplied by way of illustration of the invention and shall not be understood as a limitation thereof. For example, the characteristics shown or described insofar as they are part of one form of embodiment can be adopted on, or in association with, other forms of embodiment to produce another form of embodiment. It is understood that the present invention shall include all such modifications and variants.

**[0032]** With reference to fig. 1, a chair 10 can comprise two support frames, for example a rear frame 11, normally having an essentially vertical development, and a front frame 12, opposite the rear frame 11 and also with an essentially vertical development.

**[0033]** The rear frame 11 can be provided with a pre-assembled backrest 13.

**[0034]** In some forms of embodiment, each frame, both the rear one 11 and the front one 12, can include two support legs 14, connected to each other by one or more horizontal cross-pieces, respectively rear cross-piece 15a and front cross-piece 15b.

**[0035]** The two frames 11 and 12 can be connected to each other by lateral cross-pieces 16 which, in possible implementations, can be assembled perpendicular with respect to the frames 11 and 12.

**[0036]** A traction device, such as a tie-rod 19, can be provided interposed and connected between the frames 11 and 12, in cooperation with the lateral cross-pieces 16 and the rear 15a and/or front cross-pieces 15b, to confer solidity and durability to the assembly of the chair

10, as will become clear hereafter in the present description.

**[0037]** In particular, the tie-rod 19 is configured to exert a linear traction force  $F$  on the two frames 11 and 12: the traction force  $F$  lies on a first lying plane of the traction device 19 and is applied transversely to a second lying plane of each of the two frames 11 and 12.

**[0038]** Furthermore, making a connection through mechanical interference between the tie-rod 19 and the rear 15a and/or front cross-pieces 15b can allow to reduce the quantity and complexity of the operations necessary to produce the chair 10, consequently reducing the production costs, and making assembly simpler and faster.

**[0039]** In one example, described with reference to fig. 1, a single rear horizontal cross-piece 15a is provided, which connects the two legs 14 of the rear frame 11 to each other, and a single horizontal front cross-piece 15b, which connects the two legs 14 of the front frame 12 to each other.

**[0040]** In other forms of embodiment (not shown in the drawings), for each pair of legs 14, an upper horizontal cross-piece and a lower horizontal cross-piece may be provided, overlapping each other and distanced along the vertical development of the legs 14.

**[0041]** Fig. 1 is used to describe forms of embodiment in which there is a single pair of lateral cross-pieces 16, positioned substantially on opposite sides with respect to a median axis of the chair 10, in correspondence with the disposition of the legs 14.

**[0042]** Other solutions can provide two or more opposite pairs of lateral cross-pieces 16.

**[0043]** The chair 10 can include, conventionally, connection members 17 between the lateral cross-pieces 16 and the frames 11 and 12.

**[0044]** Fig. 1 is used to describe forms of embodiment in which the connection members 17 can include pins 17a, inserted into suitable blind holes 17b that function as seatings for the pins 17a and are made in each of the ends of the lateral cross-pieces 16 and in the zone of each frame 11, 12 used to connect the lateral cross-pieces 16 themselves.

**[0045]** In possible implementations, instead of the pin 17a, tenons can be used, made in a piece at the ends of the cross-pieces 16, and instead of the blind holes 17b corresponding mortises can be used, made in the frames 11, 12, which function as seatings for said tenons.

**[0046]** The two frames 11 and 12 and the corresponding lateral cross-pieces 16 are configured to define, in the assembled condition, a support structure on which a support plane can be located and possibly attached, for example by jointing or gluing, which in this specific case of the chair 10 is defined by a seat part 18.

**[0047]** The chair 10 can also include a single traction device or tie-rod 19, which can be disposed for example lying on a plane substantially orthogonal to those defined by the rear frame 11 and the front frame 12, for example on a horizontal plane.

**[0048]** Furthermore, the tie-rod 19 can be positioned

at the center with respect to the frames 11 and 12 and the horizontal cross-pieces 16.

**[0049]** The tie-rod 19 can be located under the seat part 18, so that it is hidden from sight during the normal use of the chair 10.

**[0050]** The tie-rod 19 is put in cooperation with the two frames 11 and 12, to determine, when driven, a desired traction to bring the two frames 11 and 12 reciprocally closer. This traction can be exerted by the tie-rod 19 in a direction lying on its lying plane.

**[0051]** In some forms of embodiment, described using fig. 1, the tie-rod 19 can include two traction bars, for example a rear traction bar 20 and a front traction bar 21, both connected to a handle 22, which functions as a drive element on the tie-rod 19.

**[0052]** The handle 22 is driven to determine the application of the traction force  $F$  on the frames 11 and 12, and hence to put the tie-rod 19 in a condition of traction.

**[0053]** In possible solutions, described for example with reference to fig. 1, the traction bars 20, 21 can be disposed reciprocally coaxial and opposite with respect to the handle 22.

**[0054]** The traction bars 20, 21 can be equipped with a threaded end 20a, 21a, and a hooked end 20b, 21b, or an eyelet, opposite the respective threaded end 20a, 21a.

**[0055]** The handle 22 can be disposed in a substantially central position between the two traction bars 20, 21 and can be hollow with an internal mother screw, to at least partly house the threaded ends 20a, 21a.

**[0056]** In some forms of embodiment, the tie-rod 19 can also include one or more attachment elements to the frames 11 and 12, for example a rear attachment element 23 and a front attachment element 24 which respectively allow the connection of the tie-rod 19 with the front frame 11 and the rear frame 12.

**[0057]** The rear attachment element 23 can include two arms 25 each having an end converging toward a common top 27, to define a convex geometry, substantially V-shaped, of the rear attachment element 23.

**[0058]** In the same way, the front attachment element 24 can have a V-shape defined by two arms 26 converging toward a common top 28.

**[0059]** In some forms of embodiment, at the opposite end with respect to said top 27, 28, each arm 25, 26 can have a curved end 29.

**[0060]** The curved end 29 can include an attachment segment 30 inclined with respect to the part of the respective arm 25, 26 comprised between the top 27, 28 and the curved end 29.

**[0061]** In possible implementations, the attachment segment 30 can have a substantially rectilinear development along a longitudinal axis lying on the same plane or on a parallel plane with respect to the lying plane of the tie-rod 19, or, in alternative implementations, the longitudinal axis can lie on a plane inclined with respect to the lying plane of the tie-rod 19.

**[0062]** Fig. 1 is used to describe forms of embodiment

in which the attachment segments 30 of the arms 25, 26 develop along longitudinal axes parallel to each other and to the lying planes of the frames 11 and 12, and essentially orthogonal to the lying plane of the tie-rod 19 and substantially parallel.

**[0063]** The longitudinal axes of the attachment segments 30 are identified in fig. 1 by the alphanumerical references X1, X2, X3, X4.

**[0064]** Housing seatings can be made in the rear 15a and front cross-pieces 15b, respectively front housing seatings 31a and rear housing seatings 31b, configured each to house an attachment segment 30 of an arm 25 or an arm 26.

**[0065]** The positioning of the attachment segments 30 in the respective housing seatings 31 a, 31 b determines an attached condition of the tie-rod 19.

**[0066]** Figs. 1 and 2 can be used to describe forms of embodiment in which each cross-piece 15a, 15b is provided with two housing seatings 31a, 31b respectively.

**[0067]** In particular, fig. 2 is used to describe by way of example both said attached condition (on the left in fig. 2) in which the attachment segment 30 is inserted inside the housing seating 31a, 31b, and also a non-attached condition (on the right in fig. 2), in which the housing seating 31a, 31b is free.

**[0068]** Each housing seating 31a, 31b can be made in the corresponding rear cross-piece 15a or front cross-piece 15b, for example by a single milling operation.

**[0069]** In some forms of embodiment, the housing seatings 31a, 31b can be made in the lower part of the cross-pieces 15a, 15b, and can be open on two sides, in particular downward and toward a zone of the chair 10 comprised between the rear frame 11 and the front frame 12 and possibly subtended by the seat part 18.

**[0070]** Inside the cross-pieces 15a, 15b, each of the housing seatings 31a, 31b can extend, in a direction parallel to the longitudinal axis X1-X4 of the corresponding attachment segment 30 (vertical in the case shown by way of example with reference to fig. 1) for a height about equal to the length of said attachment segment 30.

**[0071]** In a direction parallel to the lying plane of the tie-rod 19, each of the housing seatings 31a, 31b can have a depth inside the respective cross-piece 15a, 15b about equal to the length of the curved end 29 of the arm 25, 26 whose attachment segment 30 it houses.

**[0072]** Each housing seating 31a, 31b can also have a transverse amplitude which, for at least part of said depth, is at least equal to the thickness of the attachment segment 30 it has to house.

**[0073]** In some forms of embodiment, the transverse amplitude is constant along the whole depth of the housing seating 31a, 31b.

**[0074]** In other forms of embodiment, the transverse amplitude is variable along the depth of the housing seating 31a, 31b.

**[0075]** In possible implementations, for a section communicating with the outside toward the zone of the chair 10 comprised between the frames 11 and 12, the trans-

verse amplitude of each housing seating 31a, 31b can be less than the thickness of the attachment segment 30, and for the remaining internal section it can be more than said thickness.

**[0076]** Furthermore, the housing seatings 31a, 31b can have a rectilinear development and can be inclined with respect to a direction perpendicular to the cross-piece 15a, 15b and parallel to the direction of application of the traction force F, that is, rotated on a plane substantially parallel to the lying plane of the tie-rod 19. This inclination or rotation can be defined by an angle  $\alpha$  comprised between 30° and 180°.

**[0077]** In implementations described using figs. 1 and 2, the housing seatings 31a, 31 b can be reciprocally convergent toward the center of the chair 10.

**[0078]** The housing seatings 31a, 31b can be delimited by a perimeter wall having at least a holding surface 32a, 32b interposed at least partly between the attachment segment 30 and the handle 22, and against which, during use, that is, in the traction condition, the attachment segment 30 abuts due to the effect of the traction performed by the tie-rod 19.

**[0079]** Each holding surface 32a, 32b can be planar, or curved, for example cylindrical, and can develop in a direction parallel to the longitudinal axis X1-X4 of the attachment segment 30 housed in the corresponding housing seating 31 a, 31b.

**[0080]** Furthermore, each holding surface 32a, 32b can be inclined, or substantially orthogonal, to the direction of application of the traction force F applied on the cross-pieces 15a, 15b by the tie-rod 19 and hence can apply on the attachment segment 30 a holding force with an inclined or parallel direction and the opposite sense with respect to the traction force F.

**[0081]** In this way, each holding surface 32a, 32b can hold the attachment segment 30 inside the housing seating 31 a, 31b.

**[0082]** In possible solutions of the chair 10, each arm 25, 26 can diverge from the corresponding top 27, 28 of the respective attachment element 23, 24, with an inclination that can be equal to the angle  $\alpha$  as above.

**[0083]** In some forms of embodiment, each curved end 29 of the arms 25, 26 can include a connection portion 33, which connects the attachment segment 30 to the remaining part of the respective arm 25, 26 that extends to the top 27, 28 of the corresponding attachment element 23, 24.

**[0084]** The connection portion 33 of the curved end 29 can be coplanar with respect to the part of the arm 25, 26 that extends as far as the respective top 27, 28 and inclined with respect to the latter.

**[0085]** In these forms of embodiment, described by way of example using fig. 1, the arms 25, 26 can diverge from the respective top 27, 28 by a bigger angle than that of the connection portion 33. Consequently, the connection portion 33 can define a partial closure of the V-shape of the respective attachment element 23, 24 toward the central zone of the corresponding cross-piece 15a, 15b.

**[0086]** In possible implementations, the inclination of the connection portion 33 with respect to a direction orthogonal to the cross-pieces 15a, 15b can be equal to the angle  $\alpha$  described above.

**[0087]** Fig. 3 is used to describe forms of embodiment, which can be combined with all the forms of embodiment described here, in which each housing seating 31 a, 31b is formed by a first portion, or external portion 131a, 131b, having a depth, measured in a direction orthogonal to the cross-piece 15a, 15b and parallel to the direction of application of the force F, at least greater than half the thickness of the cross-piece 15a, 15b, and by a second portion or internal portion, 231a, 231b, having, in the same direction, a depth at least equal to the thickness of an attachment segment 30.

**[0088]** In these forms of embodiment, the external portion 131 a, 131b can have a first penetration height H1 inside the cross-piece 15a, 15b, measured with respect to the external surface 115a, 115b of the cross-piece 15a, 15b in a direction orthogonal to the direction of application of the force F and essentially parallel to the longitudinal axis X1-X4 of the corresponding attachment segment 30, while the internal portion 231a, 231b can have a second penetration height H2 inside the cross-piece 15a, 15b greater than said first height H1.

**[0089]** In these forms of embodiment, the holding surface 32a, 32b of the housing seating 31a, 31b is part of the perimeter wall that delimits the corresponding internal portion 231 a, 231 b described above, and at least partly surrounds the attachment segment 30, exerting thereon a holding force with a parallel direction and opposite sense with respect to the traction force F exerted by the tie-rod 19.

**[0090]** In this way the advantage is obtained of being able to anchor the tie-rod 19 to the rear 11 and front frame 12 only by inserting the attachment segments 30 into the respective housing seatings front 31a and rear 31b.

**[0091]** The holding surfaces 32a, 32b allow to keep the attachment segments 30 of the attachment elements 23, 24 in the housing seatings 31a, 31b, even and especially when the tie-rod 19 is subjected to traction.

**[0092]** Consequently, advantageously, the need to perform deformations on the ends of the attachment elements 23, 24, so that holes can be made therein in which pin screws or attachment bolts are inserted is obviated. Additionally, it is not necessary to make additional holes in the cross-pieces 15a, 15b for connection of the attachment elements 23, 24 by means of said pin screws or attachment bolts.

**[0093]** Therefore, it is possible to reduce both the times and also the costs of producing the chair 10. Indeed, besides the blind holes 17b or the mortises of the connection members 17, the working to be carried out on the components of the chair 10 comprises only the milling operations to obtain the housing seatings 31a, 31b.

**[0094]** The chair 10 made as described above also has the advantage, compared with the state of the art, that it can be assembled easily and effortlessly by the final user,

without the producer having to carry out any pre-assembly operations which would affect the cost of the chair.

**[0095]** In fact, the assembly of the chair 10 includes only operations that can be carried out by the final user.

**[0096]** These operations provide, first of all, to connect the lateral cross-pieces 16 to the rear frame 11 and front frame 12 using the connection members 17.

**[0097]** It is also provided to associate the attachment elements, rear 23 and front 24, to the traction bars, rear 20 and front 21, for example by inserting the tops 27 and 28 of the former into the respective hooked ends 21 a, 21 b of the latter.

**[0098]** Then the attachment segments 30 can be inserted into the housing seatings, rear 31a and front 31b, and subsequently the handle 22 can be rotated to drive the tie-rod 19 and apply a traction force to move the rear frame 11 and the front frame 12 reciprocally nearer each other.

**[0099]** The housing seatings 31 a, 31 b are distanced from each other along the width of the cross-piece 15a, 15b in which they are made, so that the traction force is distributed uniformly over the whole respective cross-piece 15a, 15b.

**[0100]** The cross-pieces 15a, 15b transmit the traction force to the frames 11 and 12 due to the fact that they are attached to them.

**[0101]** In particular, the handle 22 can rotate around its longitudinal axis, as indicated by the arrow R in fig. 1. Said rotation can determine the screwing of the two threaded ends 20a and 21 a inside the handle 22.

**[0102]** The traction bars 20, 21 are consequently brought near each other and, as a result, this can generate a traction acting on both the attachment elements 23, 24 due to the connection between the tops 27, 28 and the hooked ends 20b, 21b.

**[0103]** The attachment elements 23, 24, in their turn, tend to move the two frames 11 and 12 toward the center of the chair 10 and to determine the reciprocal drawing together thereof.

**[0104]** The drawing together is contrasted by the lateral cross-pieces 16 which are thus anchored forcefully to the frames 11 and 12, putting the chair 10 under the desired tension and stability. In fact, the movement of the frames 11 and 12 also determines the stable insertion of the pins 17a into the corresponding blind holes 17b, in this way defining a stable and secure assembled condition of the chair 10.

**[0105]** The handle 22 and the two threaded ends 20a and 21 a thus constitute an effective adjustment device 40 of the traction force.

**[0106]** It is obvious that to dis-assemble the chair 10, a substantially inverse operation is provided to the one described above.

**[0107]** A variant of this geometric disposition, not shown in the drawings, provides that the two arms 25 and 26 are substantially T-shaped, so that all in all the attachment elements 23, 24 and the tie-rod 19 are substantially shaped like a double T.

**[0108]** As a variant solution, not shown, it may be provided to use only the rear attachment element 23, or only the front attachment element 24. This variant may also provide that, respectively, the front traction bar 21 or the rear traction bar 20 also functions as an attachment element. In this solution, the front traction bar 21 or the rear traction bar 20 can be directly connected to the corresponding cross-piece 15b or 15a, for example if the corresponding hooked end 21b or 20b has an attachment segment 30 compatible in shape with insertion into a housing seating 31b or 31a.

**[0109]** According to another variant, not shown, both the hooked ends 20b and 21b can have an attachment segment 30 to be directly connected to the respective cross-pieces 15a, 15b, without using specific attachment elements 23, 24, but the traction bars 21 and 20 themselves acting as attachment elements.

**[0110]** In combination with the alternatives illustrated above, it is possible that the tie-rod 19 has only one threaded part and the handle 22 has only one mother screw end, while the other end is connected, rotatably or rigidly, to the corresponding non-threaded part of the tie-rod 19, but is not active in traction. In this case there is an asymmetrical traction and only one of the frames 11 and 12 moves with respect to the other which stays still.

**[0111]** Alternatively, it is possible that the handle 22 is externally threaded and the threaded ends 20a and/or 21 a are hollow and threaded internally, functioning as a mother screw.

**[0112]** With regard to the construction materials, the frames 11 and 12, the cross-pieces 15a and 15b, and the lateral cross-pieces 16 are preferably made of wood, the tie-rod 19 is preferably made of metal, but can have plastic or rubber parts. For example, the handle 22, which has an ergonomic shape to facilitate gripping, may preferably be made of rubber, but can also be made of rigid plastic with rubber gripping inserts, or again it may be made of metal with a rubber covering.

**[0113]** It is clear that modifications and/or additions of parts may be made to the furnishing element as described heretofore, without departing from the field and scope of the present invention.

**[0114]** It is also clear that, although the present invention has been described with reference to some specific examples, a person of skill in the art shall certainly be able to achieve many other equivalent forms of furnishing element, having the characteristics as set forth in the claims and hence all coming within the field of protection defined thereby.

## Claims

1. Furnishing element comprising at least two opposite support frames (11, 12) and a traction device (19) configured to be interposed and connected between said at least two frames (11, 12) and that comprises an intermediate drive element (22), to define a trac-

tion condition and obtain a reciprocal drawing together of said at least two frames (11, 12), **characterized in that** said traction device (19) comprises a plurality of attachment segments (30) provided in an opposite position on one side and on the other with respect to the drive element (22), **and in that** said at least two frames (11, 12) comprise a plurality of housing seatings (31a, 31b) configured to each receive, in an attached condition, a respective attachment segment (30), each of the housing seatings (31 a, 31b) being internally delimited at least by a holding surface (32a, 32b) configured to be at least partly interposed, in the attached condition, between said attachment segment (30) and said drive element (22), and to be in abutment, in the traction condition, with the respective attachment segment (30) inserted in the respective housing seating (31a, 31b).

2. Furnishing element as in claim 1, **characterized in that** said traction device (19) is configured to exert, in the traction condition and by means of the selective drive of the drive element (22), a traction force (F) provided along a first lying plane of the traction device (19) and applied transversely to a second lying plane of each of said at least two frames (11, 12).

3. Furnishing element as in claim 1 or 2, **characterized in that** each of said frames (11, 12) is provided with a pair of support legs (14) connected to each other by one or more cross-pieces (15a, 15b), said housing seatings (31a, 31b) being made on said cross-pieces (15a, 15b).

4. Furnishing element as in claim 3, **characterized in that** said housing seatings (31a, 31b) are made open on one side of the corresponding cross-piece (15a, 15b) facing toward the inside between the two frames (11, 12).

5. Furnishing element as in claim 3 or 4, **characterized in that** said housing seatings (31a, 31b) are made open on one side of the corresponding cross-piece (15a, 15b) facing toward a zone comprised between two legs (14) of a respective frame (11, 12).

6. Furnishing element as in claims 2 and 4, or 2 and 5, **characterized in that** each of said housing seatings (31a, 31b) comprises a first portion (131a, 131b), having a depth, in a direction parallel to the direction of application of the traction force (F), greater than or equal to half the thickness of the corresponding cross-piece (15a, 15b), and a second portion (231a, 231b), having, in said direction, a depth at least equal to the thickness of an attachment segment (30), said second portion (231a, 231b) having a penetration height (H2) inside said cross-piece (15a, 15b) greater than a penetration height (H1) of said first portion (131a, 131b).

- 7. Furnishing element as in any claim from 2 to 6, **characterized in that** said housing seatings (31 a, 31 b) have a rectilinear development and develop, in depth, in the respective cross-piece (15a, 15b), in a direction parallel to the first lying plane of the traction device (19) and inclined with respect to a direction orthogonal to said cross-piece (15a, 15b) and to the direction of application of the traction force (F). 5
  
- 8. Furnishing element as in any claim from 2 to 7, **characterized in that** said attachment segments (30) extend transversely with respect to the first lying plane of the traction device (19). 10
  
- 9. Furnishing element as in claim 8, **characterized in that** said attachment segments (30) have an essentially rectilinear development along longitudinal axes (X1, X2, X3, X4) substantially perpendicular to the first lying plane of said traction device (19) and to the direction of application of the traction force (F). 15  
20
  
- 10. Furnishing element as in any claim hereinbefore, **characterized in that** said housing seatings (31a, 31b) are obtained by means of a single milling operation. 25
  
- 11. Furnishing element as in any claim from 2 to 10, **characterized in that** said traction device (19) comprises at least one traction bar (20, 21) provided with a threaded end (20a, 21 a) connected to said drive element (22) and with a hooked end (20b, 21b), opposite said threaded end (20a, 21a), at least one connection element (23, 24) provided with at least one top (27, 28) toward which arms (25, 26) converge, inclined with respect to the direction of application of the traction force (F), said at least one top (27, 28) being connected to said hooked end (20b, 21b) and defining an end of said arms (25, 26), wherein each of said arms (25, 26) comprises, opposite said top (27, 28), a curved end (29) having at least one of said attachment segments (30) as its terminal part. 30  
35  
40
  
- 12. Furnishing element as in any claim from 2 to 10, **characterized in that** said traction device (19) comprises at least a pair of traction bars (20, 21) opposite said drive element (22), and each provided with a threaded end (20a, 21a) connected to said drive element (22) and with one end, opposite said threaded end (20a, 21a), in which there is one of said attachment segments (30). 45  
50

55





EUROPEAN SEARCH REPORT

Application Number  
EP 14 18 0860

5

10

15

20

25

30

35

40

45

50

55

DOCUMENTS CONSIDERED TO BE RELEVANT			
Category	Citation of document with indication, where appropriate, of relevant passages	Relevant to claim	CLASSIFICATION OF THE APPLICATION (IPC)
X	GB 648 106 A (GREAVES & THOMAS LTD) 28 December 1950 (1950-12-28) * figures 3,4 * * page 2, lines 2-12 * -----	1-5,8-12	INV. A47C4/02
X	US 1 089 007 A (PONTON ARTHUR [US]) 3 March 1914 (1914-03-03) * figures 1-3 * -----	1-3, 7-10,12	
X	EP 2 005 860 A1 (VITERIA PETTARINI S R L [IT]) 24 December 2008 (2008-12-24) * figure 2 * * paragraph [0047] * -----	1-4,7,8, 10-12 5,6,9	
Y	EP 0 712 594 A1 (BUIANI LINO & FIGLI SRL [IT]) 22 May 1996 (1996-05-22) * figures 1,3a,5 * * column 4, lines 26-37 * -----	5,6,9 1	
A	US 660 208 A (BLAISDELL BYRON R [US]) 23 October 1900 (1900-10-23) * figure 2 * * page 1, lines 38-48 * -----	1,5,9	
			A47C
The present search report has been drawn up for all claims			
Place of search		Date of completion of the search	Examiner
The Hague		22 January 2015	Sainz Martínez, M
CATEGORY OF CITED DOCUMENTS			
X : particularly relevant if taken alone Y : particularly relevant if combined with another document of the same category A : technological background O : non-written disclosure P : intermediate document		T : theory or principle underlying the invention E : earlier patent document, but published on, or after the filing date D : document cited in the application L : document cited for other reasons ..... & : member of the same patent family, corresponding document	

EPO FORM 1503 03.82 (P04C01)

**ANNEX TO THE EUROPEAN SEARCH REPORT  
ON EUROPEAN PATENT APPLICATION NO.**

EP 14 18 0860

5

This annex lists the patent family members relating to the patent documents cited in the above-mentioned European search report. The members are as contained in the European Patent Office EDP file on The European Patent Office is in no way liable for these particulars which are merely given for the purpose of information.

22-01-2015

10

Patent document cited in search report	Publication date	Patent family member(s)	Publication date
GB 648106 A	28-12-1950	NONE	
US 1089007 A	03-03-1914	NONE	
EP 2005860 A1	24-12-2008	AT 454837 T EP 2005860 A1	15-01-2010 24-12-2008
EP 0712594 A1	22-05-1996	EP 0712594 A1 IT UD940187 A1 US 5601339 A	22-05-1996 20-05-1996 11-02-1997
US 660208 A	23-10-1900	NONE	

15

20

25

30

35

40

45

50

55

EPO FORM P0459

For more details about this annex : see Official Journal of the European Patent Office, No. 12/82