

(19)



(11)

**EP 2 843 117 A1**

(12)

**EUROPEAN PATENT APPLICATION**

(43) Date of publication:  
**04.03.2015 Bulletin 2015/10**

(51) Int Cl.:  
**D06F 58/20** (2006.01) **D06F 58/04** (2006.01)  
**D06F 58/06** (2006.01)

(21) Application number: **13181859.3**

(22) Date of filing: **27.08.2013**

(84) Designated Contracting States:  
**AL AT BE BG CH CY CZ DE DK EE ES FI FR GB GR HR HU IE IS IT LI LT LU LV MC MK MT NL NO PL PT RO RS SE SI SK SM TR**  
Designated Extension States:  
**BA ME**

- **Santarossa, Marco**  
**33080 Porcia (PN) (IT)**
- **Vian, Alessandro**  
**33080 Porcia (PN) (IT)**

(71) Applicant: **Electrolux Appliances Aktiebolag**  
**105 45 Stockholm (SE)**

(74) Representative: **Petrucelli, Davide et al**  
**Electrolux Italia S.p.A.**  
**Corso Lino Zanussi 30**  
**33080 Porcia (PN) (IT)**

(72) Inventors:  
• **Giovannetti, Andrea**  
**33080 Porcia (PN) (IT)**

(54) **Rotary-drum laundry dryer**

(57) A rotary-drum laundry dryer (1) comprising a revolving drum (3) structured for housing the laundry to be dried, a hot-air generator (6) structured to supply a stream of hot air through the revolving drum (3), and a lower supporting base (11) which is structured for resting on the floor and for housing at least part of the hot-air generator (6). The hot-air generator (6) in turn comprises:  
- an air conduit; and

- air circulating means which are located along the air conduit and are structured to produce, inside the air conduit, an airflow (f) which flows through the revolving drum (3) and over the laundry inside the drum (3). The rotary-drum laundry dryer (1) is characterized in that its rear wall (2b) comprises a supporting bulkhead (14a) made of plastic material; and the lower supporting basement or socle (11) is also made in plastic material.

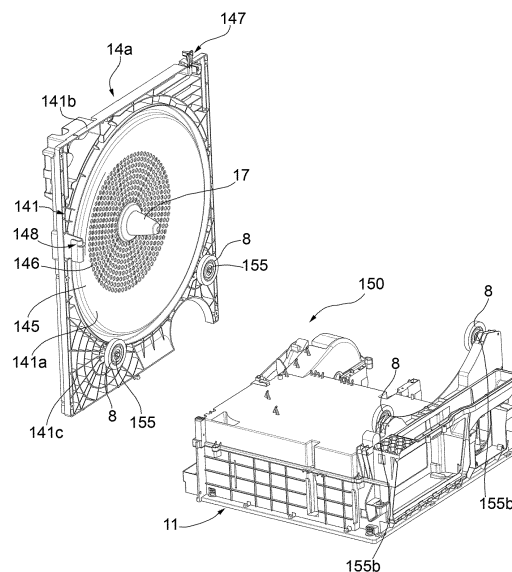

FIG. 10

**EP 2 843 117 A1**

## Description

**[0001]** The present invention relates to a rotary-drum laundry dryer.

**[0002]** In particular, the present invention relates to a rotary-drum home laundry dryer to which the following description refers purely by way of example without implying any loss of generality.

**[0003]** As is known, rotary-drum home laundry dryers currently on the market generally comprise: a substantially parallelepiped-shaped, outer boxlike casing structured for resting on the floor; a substantially cylindrical rotatable drum which is structured for housing the laundry to be dried and is housed in axially rotating manner inside the casing in order to rotate about an horizontally-oriented longitudinal reference axis, directly facing a laundry loading/unloading opening formed in the front wall of the casing; a porthole door hinged to the front wall of the casing to rotate to and from a closing position in which the door rests completely against the front wall of the casing to close the laundry loading/unloading opening and airtight seal the rotatable drum; an electrically-powered motor assembly which is housed inside the casing and is structured for driving into rotation the rotatable drum about its longitudinal reference axis; an open-circuit or closed-circuit, hot-air generator which is housed inside the casing and is structured to circulate inside the rotatable drum a stream of hot air which has a very low moisture content and flows through the rotatable drum and over the laundry inside the drum to rapidly dry the laundry; and finally an electronic central control unit which controls both the motor assembly and the hot-air generator to perform, on command, one of the user-selectable drying cycles stored in the same central control unit.

**[0004]** In a first kind of rotary-drum home laundry dryers currently on the market, the rotatable drum furthermore consists in a substantially cylindrical rigid tubular body having open ends, while in a second kind of rotary-drum home laundry dryers said substantially cylindrical rigid tubular body has one end which is closed by a bottom wall rigidly fixed to the tubular body. In both cases, the rotatable drum extends substantially horizontally inside the boxlike casing, locally aligned to the laundry loading/unloading opening, and is structured for resting on a number of idle supporting rollers which are arranged at the two axial ends of the tubular body locally parallel to the drum longitudinal reference axis, and are attached to the appliance casing in free revolving manner so as to allow the tubular body to freely rotate about its horizontally-oriented longitudinal reference axis.

**[0005]** The front rim of the tubular body surrounds the laundry loading/unloading opening and is coupled in axially rotating manner to the front wall of the boxlike casing; whereas the rear rim of the tubular body abuts against the rear wall of the boxlike casing and is coupled in axially rotating manner directly to said rear wall. By the way, the front wall comprises an annular frame and a covering panel; the covering panel belonging to the cabinet of the

laundry dryer. In actual use the covering panel covers the annular frame.

**[0006]** The stream of hot air produced by the hot-air generator usually enters into the tubular body via an intake air-vent made in the rear wall of the boxlike casing, within the perimeter of the rear rim of the tubular body, flows inside the tubular body for the entire length of the latter, and finally comes out of the tubular body via an escape air-vent usually carried out on the annular frame that delimits the laundry loading/unloading opening on the front wall of the casing.

**[0007]** To avoid air leakages from the two axial ends of the tubular body, a first circular sealing gasket is generally interposed between the front rim of the tubular body and the front wall of the casing, whereas a second circular sealing gasket is generally interposed between the rear rim of the tubular body and the rear wall of the appliance casing.

**[0008]** In most of the rotary-drum home laundry dryers currently on market, the first and the second circular sealing gaskets are usually recessed into a circular groove carried out on the front and rear wall of the casing, respectively, and are firmly hold in the groove so as to remain stationary when the rotatable drum rotates about its longitudinal reference axis.

**[0009]** Since, during a drying process, laundry within the rotatable drum may tangle due to the rotational movement of the drum itself, the back of the rotatable drum, i. e. the rear wall of the boxlike casing or the bottom wall fixed to the tubular body of the drum, may be provided with an anti-entangling nose that protrudes from the rear wall closing the rear end of the drum tubular body, roughly at centre of the rear rim of the tubular body, and extends inside the tubular body locally substantially parallel to the drum longitudinal reference axis. This nose is shaped/dimensioned so to prevent, when the drum rotates, the laundry from entangling and block the hot-air intake vent located on said wall or unbalance the drum rotation.

**[0010]** Aim of the present invention is to simplify the structure of the rear wall of the boxlike casing so as to significantly reduce the appliance production costs and simplifying the drying machine assembling process.

**[0011]** In compliance with the above aims, according to the present invention there is provided a rotary-drum laundry dryer comprising a revolving drum structured for housing the laundry to be dried, a hot-air generator structured to supply a stream of hot air through said revolving drum, and a lower supporting base which is structured for resting on the floor and for housing at least part of the hot-air generator. The hot-air generator (6) in turn comprises:

- an air conduit; and
- air circulating means which are located along the air conduit and are structured to produce, inside the air conduit, an airflow which flows through the revolving drum and over the laundry inside the drum. The rotary-drum laundry dryer is **characterized in that** its

rear wall comprises a supporting bulkhead made of plastic material; and the lower supporting basement is also made in plastic material.

**[0012]** Furthermore, the rotary-drum laundry dryer is characterized in that its rear wall comprises a supporting bulkhead made of plastic material; at least a portion of a centrifugal impeller scroll made also of plastic material being carried out in one piece with the supporting bulkhead; and/or at least one supporting boss of a drum supporting roller being also made of plastic material and carried out in one piece with the supporting bulkhead.

**[0013]** Moreover, the rotary-drum laundry dryer is characterized in that its rear wall comprises a supporting bulkhead made of plastic material; at least one supporting boss of a drum supporting roller being also made of plastic material and carried out in one piece with the supporting bulkhead; and at least one supporting boss of a supporting roller being carried out in one piece with a lower supporting basement.

**[0014]** A number of non-limiting embodiments of the present invention will now be described, by way of example, with reference to the accompanying drawings, in which:

- Figures 1 is a perspective view of a rotary-drum home laundry dryer made in accordance with the teachings of the present invention;
- Figure 2 is a transversal section view of the Figure 1 laundry dryer;
- Figure 3 a perspective view with parts removed for clarity sake of the laundry dryer of Figures 1, 2;
- Figure 4 is a perspective front view of a portion of the rear wall of the Figures 1, 2, 3 laundry dryer;
- Figure 5 is a perspective rear view of the portion of the rear wall of Figure 4;
- Figure 6 is a front view of the portion of the rear wall of Figures 4, 5;
- Figure 7 is a transversal section B-B of an element belonging to the rear wall of Figures 4, 5, 6;
- Figure 8 is a perspective rear view of the portion of the rear wall of Figures 4, 5, 6 coupled with the corresponding cover;
- Figure 9 is a perspective front view of a first embodiment of the portion of the rear wall coupled with a lower supporting basement or socle;
- Figure 10 is a perspective front view of a second embodiment of the portion of the rear wall coupled with a lower supporting basement or socle;
- Figure 11 is a perspective front view of a third embodiment of the portion of the rear wall coupled with a lower supporting basement or socle.

**[0015]** With reference to Figures 1 and 2, reference number 1 indicates as a whole a rotary-drum home laundry dryer.

**[0016]** The rotary-drum home laundry dryer comprises:

- a preferably, though not necessarily, parallelepiped-shaped, outer boxlike casing 2 which is built for resting on the floor and is provided with reciprocally-faced front and rear walls 2a and 2b;
- a substantially cylindrical, sleeve-shaped rotatable drum 3 (Figure 2) structured for housing the laundry to be dried, and which is fixed in axially rotating manner inside the outer casing 2, directly facing a laundry loading/unloading pass-through opening formed on the preferably substantially vertically-oriented, front wall 2a of casing 2;
- and a porthole door 4 hinged to the front wall 2a of casing 2 so to be able to rotate about a preferably, though not necessarily, vertically-oriented reference axis, to and from a closing position in which door 4 rests completely against the front wall 2a to close the laundry loading/unloading opening and substantially airtight seal the rotatable drum 3.

**[0017]** Inside the boxlike casing 2, the laundry dryer 1 additionally comprises:

- an electrically-powered motor assembly (not shown) structured for driving into rotation the rotatable drum 3 about its longitudinal reference axis;
- an open-circuit or closed-circuit, hot-air generator 6 (Figure 2) which is structured to circulate through the rotatable drum 3 a stream of hot air having a low moisture level, and which flows over and rapidly dries the laundry located inside the rotatable drum 3; and
- an electronic central control unit (not shown) which controls both the motor assembly and the hot-air generator 6 to perform, on command, one of the user-selectable drying cycles preferably, though not necessarily, stored in the same central control unit.

**[0018]** In the present invention preferably, though not necessarily, the hot-air generator 6 can be a heat-pump which is envisaged for gradually drawing air from the rotatable drum 3; rapidly cooling down the wet air arriving from the rotatable drum 3 so to extract and retain the surplus moisture in the air drawn from the rotatable drum 3; and then rapidly heating the dehumidified air to a predetermined temperature, normally higher than the temperature of the air coming from the rotatable drum 3; and finally feeding the heated, dehumidified air back into the rotatable drum 3, where the air flows over the laundry inside the drum to rapidly dry said laundry. A heat-pump is particularly suitable in carrying out the invention because the dry air which is used for drying the laundry has a quite low temperature and therefore it doesn't damage the plastic components of the casing.

**[0019]** In greater detail the heat-pump assembly (non shown in detail) comprises a first and a second air/refrigerant heat exchangers located inside the air recirculating conduit 21, preferably downstream of the centrifugal fan. The first air/refrigerant heat exchanger, traditionally referred to as the "evaporator" of the heat-pump circuit, is

located inside the air recirculating conduit 21 preferably downstream of the centrifugal fan, and is structured to remove/absorb heat from the airflow arriving from rotatable drum 3, thus forming the air cooling means of the hot-air generator 6. The second air/refrigerant heat exchanger, traditionally referred to as the "condenser" of the heat-pump circuit, is instead located inside the air recirculating conduit 21 downstream of the first air/refrigerant heat exchanger, and is structured to release heat to the airflow arriving from the first air/refrigerant heat exchanger, thus forming the air heating means of the hot-air generator 6.

**[0020]** As an alternative, the air heating means of hot-air generator 6 may comprise a resistor located inside the air recirculating conduit 21, preferably downstream of the centrifugal fan, whereas the air cooling means of hot-air generator 6 may comprise an air/air heat exchanger that uses the external air to cool down the airflow arriving from the rotatable drum 3.

**[0021]** With reference in particular to Figure 2 the rotatable drum 3 preferably consists in a substantially cylindrical-shaped, rigid tubular body preferably made of metal material and which extends inside the boxlike casing 2 coaxial to a preferably substantially horizontally-oriented, longitudinal reference axis L while remaining locally substantially aligned to the laundry loading/unloading opening on the front wall 2a of the boxlike casing 2. The substantially cylindrical-shaped, rigid tubular rotatable drum 3 is furthermore preferably structured for resting on a number of idle supporting rollers 8 which are arranged approximately at the two axial ends of the rotatable drum 3 with their rotation axis locally substantially parallel to the longitudinal reference axis L of the rotatable drum 3; and are fitted in free revolving manner so as to allow the rotatable drum 3 to freely rotate about its longitudinal reference axis L inside the boxlike casing 2.

**[0022]** In addition to the above, a circular front rim 3f (Figure 2) of the rotatable drum 3 surrounds the laundry loading/unloading opening carried out on the front wall 2a of boxlike casing 2 and is coupled in substantially airtight and axially rotating manner to the front wall 2a, preferably with the interposition of a first circular sealing gasket 9. A circular rear rim 3r of rotatable drum 3 instead abuts against the preferably substantially vertically-oriented, rear wall 2b of boxlike casing 2 and is coupled in substantially airtight and axially rotating manner directly to said rear wall 2b with the interposition of a second circular sealing gasket 10. Both front and rear circular sealing gaskets 9 and 10 are obviously substantially coaxial with the longitudinal reference axis L of the rotatable drum 3.

**[0023]** With reference to Figure 2, the stream of hot air produced by the hot-air generator 6 preferably enters into the rotatable drum 3 through the rear end of the rotatable drum 3, i.e. the end of the rotatable drum 3 delimited by the rear rim 3r, flows inside the rotatable drum 3 for the entire length of the latter, and finally comes out of rotatable drum 3 through the front end of the rotatable drum

3, i.e. the end of the rotatable drum 3 delimited by the front rim 3f, or vice versa.

**[0024]** In other words, the stream of hot air produced by the hot-air generator 6 preferably enters the rotatable drum 3 via an intake air-vent located in the rear wall 2b of the boxlike casing 2 and locally aligned to the rear end of the rotatable drum 3, i.e. within the perimeter of the rear rim 3r of the rotatable drum 3, and comes out of rotatable drum 3 via an escape air-vent which is preferably located either on the porthole door 4 that selectively closes the laundry loading/unloading opening of front wall 2a, or directly on the front wall 2a of the boxlike casing 2, preferably very close to the laundry loading/unloading opening.

**[0025]** With reference to Figures 1, 2 and 3 the outer boxlike casing 2 preferably comprises a substantially parallelepiped-shaped lower supporting basement or socle 11 which is structured for resting on the floor and preferably also for housing at least part of the hot-air generator 6; and a substantially parallelepiped-shaped upper boxlike cabinet 12 which is rigidly fixed to the top of the lower supporting basement or socle 11 and it is structured so as to house the rotatable drum 3.

**[0026]** With reference to Figure 2, in the example shown, in particular, the circular sealing gasket 9 is preferably, though not necessarily, stationary recessed into a circular groove or seat made on a front frame or bulkhead 13 which is preferably associated to a front panel of the upper boxlike cabinet 12, thereby forming the front wall 2a of casing 2. The circular sealing gasket 9 is arranged into the circular groove or seat so as to completely surround the laundry loading/unloading opening on the front wall 2a of the casing 2, and the front rim 3f of the rotatable drum 3 abuts directly against said front circular sealing gasket 9.

**[0027]** With reference to Figure 2 the circular sealing gasket 10 is firmly fixed to the rear wall of the upper boxlike cabinet 12, i.e. to the rear wall 2b of the boxlike casing 2, and the intake air-vent of hot-air generator 6 is incorporated into the same rear wall of the upper boxlike cabinet 12, i.e. into the rear wall 2b of the boxlike casing 2.

**[0028]** As shown in Figures 3, 8 the rear wall 2b of casing 2, preferably comprises a substantially flat, vertically-oriented supporting panel or bulkhead 14a and a cover 14b. At least one of the elements 14a, 14b (preferably both elements 14a, 14b) is made in a plastic, i.e. polymeric, material by means for instance of an injection molding process. In particular, the bulkhead 14a can be ideally divided into:

- a substantially rectangular main body 141; the main body 141 being provided with a substantially circular central bulge 141a which in turn protrudes outwardly; the central bulge 141a is surrounded by a supporting frame 141b provided with a number of reinforcing ribs 141c; and
- optionally at least a portion of a first cup-shaped face 142 (Figures 9, 10) of a scroll 150 of a centrifugal

impeller (not shown); the first cup-shaped face 142 partially protrudes downwardly from the supporting frame 141b.

**[0029]** As shown in Figures 9, 10 there are two possible embodiments of the present invention. Indeed, in the embodiment of Figure 9 a portion of a first cup-shaped face 142 of a scroll 150 is integrated into the substantially rectangular main body 141; whereas in the alternative embodiment of Figure 10 no portion of the first cup-shaped face 142 has been integrated into the main body 141.

**[0030]** By the way, as illustrated in the example of Figure 8 the whole scroll 150 is composed by the aforesaid first cup-shaped face 142 (which belongs to the bulkhead 14a) and a second cup-shaped face 143 which in turn is a portion of the cover 14b (see further on).

**[0031]** Furthermore, the first cup-shaped face 142 is provided with a through circular opening 142a for housing the relevant shaft (not shown) of a relevant fan (not shown) of a centrifugal impeller (not shown). Of course, the fan of the impeller is housed in the scroll 150.

**[0032]** Coming back now to Figure 3 a continuous circular groove 144 has been provided outside the circular outline of the substantially circular central bulge 141a. Of course, the circular groove 144 is able to house the aforementioned circular sealing gasket 10 (see above). It is obvious for the man skilled in the art that the circular groove 144 could be replaced by a substantially cylindrical gasket-supporting collar which protrudes from the inner face of the bulkhead 14a.

**[0033]** The substantially cylindrical gasket-supporting collar protrudes from the inner face of the supporting bulkhead 14a towards the rotatable drum 3 while remaining locally substantially coaxial to the longitudinal axis L of the rotatable drum 3, i.e. coaxial to the rear rim 3r of the rotatable drum 3, so as to completely surround the circular central bulge 141a, and finally has a nominal diameter greater than that of the rear rim 3r of rotatable drum 3 so as to completely surround the rear rim 3r.

**[0034]** The circular sealing gasket 10 is encircled and fitted/recessed into the gasket-supporting collar (or into the circular groove 144) preferably in substantially airtight manner, and is suitably shaped/dimensioned so as to permanently come in abutment against the rear rim 3r of the rotatable drum 3 without interruption all around the perimeter of the latter, so as to avoid any air leakage between the rear rim 3r of rotatable drum 3 and the supporting bulkhead 14a.

**[0035]** In the example shown, in particular, the circular sealing gasket 10 is preferably rigidly fixed, force-fitted into the gasket-supporting collar (or into the circular groove 144). Preferably, though not necessarily, the circular sealing gasket 10 is furthermore suitably shaped/dimensioned so as to also abut directly against the beneath-located first cup-shaped face 142 without interruption all around the perimeter of the gasket.

**[0036]** In actual use, the circular rim 3a of the rotatable

drum 3 is pressed on the sealing gasket 10 and this involves a certain wear of the sealing gasket 10. Thus the sealing gasket 10 is constructed in a material that continuously takes up the slack between the rim 3a and the outer surface of the sealing gasket 10.

**[0037]** Moreover, at least a central circular portion 145 of the circular central bulge 141a is occupied by a number of through holes 146 which permit the flow of the treating air produced by hot-air generator 6 toward the laundry that has to be dried within the rotatable drum 3.

**[0038]** Preferably, though not necessarily, a laundry anti-entangling nose 17 is provided too. Preferably, the laundry anti-entangling nose 17 protrudes from the central circular portion 145 of the circular central bulge 141a and extends in use inside the rotatable drum 3 preferably while remaining locally substantially coaxial to the longitudinal reference axis L of the rotatable drum 3, and is properly shaped/dimensioned so as to prevent, when the rotatable drum 3 rotates, the entangling of the damp laundry located into the rotatable drum 3. The anti-entangling nose 17 is furthermore preferably substantially frustoconical in shape.

**[0039]** Finally, the supporting panel or bulkhead 14a of rear wall 2b is preferably made of plastic, i.e. polymeric, material, further preferably via an injection molding process. Advantageously, the gasket-supporting collar (or the circular groove 144) is made in one piece with the same supporting bulkhead 14a during the same forming process.

**[0040]** Furthermore, even if the circular central bulge 141a has been shown in the drawings as being formed so as to close the rear end of the rotatable drum 3, it may be formed with a simplified shape so as to be (removably) coupled with a separate bulge portion piece which is provided for closing the rear end of the rotatable drum 3. In another embodiment, the circular central bulge 141a may be formed in a further simplified shape if the rotatable drum 3 is provided with a bottom wall fixedly attached to the rotatable drum 3. Such simplified shapes include planar shapes where a plurality of through holes 146 are formed for allowing the flow of drying air to enter the rotatable drum 3 via the separate bulge portion or the tubular body bottom wall which, in turn need to be pierced.

**[0041]** In the example shown, in particular, the anti-entangling nose 17, alike the gasket-supporting collar (or into the circular groove 144), is preferably made in one piece with the supporting panel or bulkhead 14a, and preferably, though not necessarily, consists in a preferably substantially ogival-shaped bulge or recess which is built approximately at center of the portion of the supporting bulkhead 14a delimited/encircled by the gasket-supporting collar (or the circular groove 144), and which protrudes inside the rotatable drum 3 preferably while remaining locally substantially coaxial to the longitudinal reference axis L of rotatable drum 3. Furthermore the ogival-shaped bulge or recess made at center of the gasket-supporting collar (or the circular groove 144) is preferably, though not necessarily, substantially in the shape

of a cone.

**[0042]** In other words, the anti-entangling nose 17 is preferably built in one piece with the supporting bulkhead 14a and the gasket-supporting collar (or the circular groove 144) preferably via an injection molding process.

**[0043]** In another embodiment shown in Figure 5 a supporting pin 17a of the anti-entangling nose 17 is carried out in a plastic piece with the rectangular main body 141.

**[0044]** In this latter case the nose 17 is mounted on the supporting pin 17a by means of well known fastening devices, for instance screws.

**[0045]** In an embodiment of the present invention at least a portion of the first cup-shaped face 142 of the scroll 150 is built in one piece with the substantially rectangular main body 141 preferably via an injection molding process.

**[0046]** With reference now to Figure 7 at least a supporting boss 155 of a corresponding idle supporting roller 8 is built also in one piece (preferably via an injection molding process) with the bulkhead 14a. Each supporting boss 155 protrudes inwardly from the bulkhead 14a, i.e. protrudes towards the rotatable drum 3 when the bulkhead 14a is mounted on the casing 2. In the present invention the bulkhead 14a could be provided in one piece either with at least a portion of the first cup-shaped face 142, or with at least a supporting boss 155, or both. In particular, in Figure 11 it is shown a bulkhead 14a provided in one piece with at least a portion of the first cup-shaped face 142 but without any roller supporting boss 155.

**[0047]** In Figure 7 is visible in greater detail the mounting of an idle supporting roller 8 on the corresponding supporting boss 155 which protrudes from the bulkhead 14a. The conical-shaped supporting boss 155 is tapered outwardly and is provided with a central bore 155a. The idle supporting roller 8 in turn comprises a bearing 8a which is mounted on the supporting boss 155 by means of a self-tapping screw 156. A reinforced wheel 8b is supported by a supporting annular structure 8c which is interposed between, and anchored to the radially outer surface of the bearing 8a and the wheel 8b. Of course, in actual use the rotatable drum 3 leans against the outer cylindrical surface of the wheel 8b.

**[0048]** As shown in Figures 2-6 other useful elements can be obtained in one piece with the bulkhead 14a. For instance a fairlead element 147 can be provided on the upper ridge of the bulkhead 14a. The fairlead element 147 is used for supporting a power cable (not shown) which enters the cabinet to electrically power at least an electronic card (not shown). The fairlead element 147 (Figure 5) consists of a tile-shaped canal 147a and of a closure plug 147b hinged to an end of the tile-shaped canal 147a. Both the tile-shaped canal 147a and the closure plug 147b can be built in one piece with the rest of the bulkhead 14a, during the same process forming the bulkhead 14a. In actual use the power cable is inserted into the tile-shaped canal 147a which is then closed by the closure plug 147b manually bent by an operator.

Moreover, the closure plug 147b is shaped for fitting with the corresponding tile-shaped canal 147a in order to firmly maintain the power cable.

**[0049]** In the embodiment shown in Figure 3, 4, 9, 10 a hook 148 is shown that protrudes from a lateral edge of the bulkhead 14a. Such a hook 148 is used to support a tube (not shown) for feeding the condensate from a collecting sump (non shown) arranged below a drying air moisture condensing unit on the bottom of the cabinet towards a removable reservoir (non shown) on the upper part of the cabinet that has to be periodically emptied by a user. Also the hook 148 can be built in one piece with the rest of the bulkhead 14a and eventually with the fairlead element 147 too.

**[0050]** With reference now to Figure 8, the cover 14b, which couples with the rear surface of the bulkhead 14a, i.e. on the surface which is opposite to that on which the rotatable drum 3 rotates, is provided with the aforesaid second cup-shaped face 143 and with a lid 157 which tightly fits with the outward surface of the central circular portion 145 of the circular central bulge 141a. The lid 157 is properly shaped/dimensioned to completely cover and close the outward surface of the central circular portion 145 so as to form/delimit, together with the supporting bulkhead 14a, an inner cavity 19 (Figure 2) which is locally aligned/faced to the rear end of the rotatable drum 3 delimited by rear rim 3r, and communicates with, i.e. is fluidly connected to, the inside of the rotatable drum 3 so that the stream of hot air circulating inside the rotatable drum 3 is guided to flow into, or flow out of, the rear end of rotatable drum 3 only via said inner cavity 19.

**[0051]** The hot-air generator 6 (in particular a heat-pump), in turn, is structured so as to communicate with, i.e. to be fluidly connected to, the inner cavity 19 made inside the rear wall of the upper boxlike cabinet 12, i.e. inside the rear wall 2b of casing 2, so as to circulate the stream of hot air to and from said inner cavity 19.

**[0052]** In the example shown, in particular, the complementary cover 14b is coupled in substantially airtight manner to the supporting bulkhead 14a, preferably without the interposition of a sealing gasket which completely surrounds the perimeter of the cover 14b, so as to form/delimit, together with the supporting bulkhead 14a, the aforesaid inner cavity 19.

**[0053]** Alike vertically-oriented supporting panel or bulkhead 14a, also the cover 14b is preferably made of plastic, i.e. polymeric, material and it is preferably, though not necessarily, made via an injection molding process.

**[0054]** The opposite side of bulkhead 14a is illustrated in Figures 5, 8. The first cup-shaped face 142 is provided with an outline collar 180a which surrounds also the opposite side of the central circular portion 145 containing the through holes 146. Similarly, the outline of the cover 14b is surrounded by an outline collar 180b. The collars 180a, 180b in cooperation form the aforesaid inner chamber 19 wherein the hot and dry air flows. The collars 180a, 180b are attached each other by means of screws for instance and/or by means of similar devices well known

in the art, such as snap-in fastening devices.

**[0055]** In other words, with reference to Figure 2, the hot-air generator 6 provides for continually dehumidifying and heating the air circulating inside rotatable drum 3 to rapidly dry the laundry located inside the drum 3, and preferably comprises:

- an air recirculating conduit 21 having a first end in communication with, i.e. fluidly connected to, the inner cavity 19 arranged inside the rear wall 2b of casing 2, and a second end in communication with, i.e. is fluidly connected to, the front end of the rotatable drum 3;
- an electrically-powered centrifugal fan (not shown) or other type of air circulating pump, which is located along the air recirculating conduit 21 and is structured to produce an airflow f which flows in closed loop through the air recirculating conduit 21 and the rotatable drum 3;
- air cooling means (not shown) which are located along the air recirculating conduit 21 preferably, though not necessarily, upstream of the air centrifugal fan, and are structured to rapidly cool the moist air arriving from rotatable drum 3 so as to cause the condensation of the surplus moisture inside the airflow f; and
- air heating means (not shown) which are located along the air recirculating conduit 21, downstream of the air cooling means and preferably also upstream of the air centrifugal fan, and which are structured for rapidly heating the dehumidified airflow f arriving from the air cooling means and directed back to rotatable drum 3, so that the airflow f directed back into rotatable drum 3 is heated to a temperature preferably, though not necessarily, higher than or equal to that of the moist air flowing out of rotatable drum 3.

**[0056]** In the example shown, in particular, the second end of the air recirculating conduit 21 communicates with, i.e. is fluidly connected to, the front end of the rotatable drum 3 via a pass-through opening made in a substantially funnel-shaped coupling element of front bulkhead 13 that delimits/surrounds the laundry loading/unloading opening on the front panel of the upper boxlike cabinet 12, i.e. on the front wall 2a of casing 2.

**[0057]** Furthermore, in the example shown a central/intermediate section of the air recirculating conduit 21 preferably extends in pass-through manner across the lower supporting basement or socle 11 of casing 2, and the air cooling means and air heating means are preferably completely housed inside said central/intermediate section of the air recirculating conduit 21. Advantageously, the lower supporting basement or socle 11 is formed by two shells coupled one onto the other, forming at least a portion of the air recirculating conduit 21 and further cavities adapted to receive therein further operational components of the dryer for operating a drying process on a laundry mass. Further advantageously, the lower sup-

porting basement 11 is made of plastic through an injection moulding process.

**[0058]** On the opposite side of the bulkhead 14a an area 185 (substantially in the shape of a circular crown) is delimited by the aforesaid collar 180a and by a substantially circular edge 187 which corresponds (on the opposite side) to the outline of the circular central bulge 141a.

**[0059]** Preferably, though not necessarily, on the area 185 a number of substantially radial reinforcing ribs 188 are provided. Similarly, the external surface of the cover 14b is preferably reinforced by means of transversal 189, circular 190 and longitudinal 191 reinforcing elements.

**[0060]** In another embodiment shown in Figures 9, 10 the supporting bulkhead 14a is made of plastic material and the supporting bosses 155b of two supporting rollers 8 are carried out in one piece with the lower supporting basement or socle 11.

**[0061]** Optionally, the supporting bulkhead 14a is made of plastic material and the lower supporting basement or socle 11 is also made in plastic material.

**[0062]** In a further embodiment shown in Figure 11 the supporting bulkhead 14a has the same features previously described with reference to Figures 3 to 5 and 8, but no roller supporting boss 155 is provided on it. Four supporting bosses 155b of four drum supporting rollers 8 are carried out in one piece with the lower supporting basement or socle 11.

**[0063]** In the embodiments represented in Figures 3-11 the first cup-shaped face 142 is directed outwardly, i.e. the concavity of the first cup-shaped face 142 of the scroll 150 is on the side opposite to the sleeve-shaped rotatable drum 3, opposite to the supporting rollers 8 and opposite to the laundry anti-entangling nose 17.

**[0064]** General operation of the rotary-drum home laundry drier 1 is clearly inferable from the above description, with no further explanation required.

**[0065]** The advantages connected to the particular structure of the rear wall of the boxlike casing are large in number.

**[0066]** For instance, the fact that the rear wall of the laundry dryer comprises a supporting bulkhead made of plastic material, and the fact that lower supporting basement or socle is also made in plastic material allow to significantly reduce the number of component parts while improving their coupling.

**[0067]** Clearly, changes may be made to the rotary-drum home laundry drier as described herein without, however, departing from the scope of the present invention.

## Claims

1. Rotary-drum laundry dryer (1) comprising a revolving drum (3) structured for housing the laundry to be dried, a hot-air generator (6) structured to supply a stream of hot air through said revolving drum (3),

and a lower supporting base (11) which is structured for resting on the floor and for housing at least part of the hot-air generator (6);  
the hot-air generator (6) in turn comprising:

- an air conduit; and
  - air circulating means which are located along the air conduit and are structured to produce, inside the air conduit, an airflow (f) which flows through the revolving drum (3) and over the laundry inside the drum (3);
- the rotary-drum laundry dryer (1) **being characterized in that** the rear wall (2b) of dryer (1) comprises a supporting bulkhead (14a) made of plastic material; and the lower supporting basement or socle (11) is also made in plastic material.
2. Rotary-drum laundry dryer, according to anyone of the foregoing Claims, **characterized in that** said at least a portion (142) of a centrifugal impeller scroll (150) corresponds to a first cup-shaped face (142) of said centrifugal impeller scroll (150).
  3. Rotary-drum laundry dryer, according to anyone of the foregoing Claims, **characterized in that** two supporting bosses (155) of two drum supporting rollers (8) are made of plastic material and carried out in one piece with said supporting bulkhead (14a).
  4. Rotary-drum laundry dryer, according to anyone of the foregoing Claims, **characterized in that** said supporting bulkhead (14a) comprises:
    - a main body (141) provided with a central bulge (141a) which in turn protrudes outwardly; and
    - a first cup-shaped face (142) protruding downwardly from said main body (141);
 the concavity of said first cup-shaped face (142) being in use on the opposite side to the rotatable drum (3).
  5. Rotary-drum laundry dryer, according to anyone of the foregoing Claims, **characterized in that** each supporting roller (8) is provided with a bearing (8a) which is mounted on said supporting boss (155); a reinforced wheel (8b) being supported by a supporting annular structure (8c) which is interposed between the outer surface of said bearing (8a) and said reinforced wheel (8b).
  6. Rotary-drum laundry dryer, according to anyone of the foregoing Claims, **characterized in that** a laundry anti-entangling nose (17) is provided which protrudes inwardly from said supporting bulkhead (14a); said nose (17) being made in one piece with said supporting bulkhead (14a).
  7. Rotary-drum laundry dryer, according to anyone of the Claims 1-5, **characterized in that** a supporting pin (17a) of an anti-entangling nose (17) is carried out in one piece with said supporting bulkhead (14a).
  8. Rotary-drum laundry dryer, according to anyone of the foregoing Claims, **characterized in that** a fairlead element (147) is provided; said fairlead element (147) being built in one piece with said supporting bulkhead (14a).
  9. Rotary-drum laundry dryer, according to Claim 8, **characterized in that** said fairlead element (147) comprises a tile-shaped canal (147a) and a closure plug (147b) hinged to an end of the tile-shaped canal (147a).
  10. Rotary-drum laundry dryer, according to anyone of the foregoing Claims, **characterized in that** a hook (148) is provided which is built in one piece with said supporting bulkhead (14a).
  11. Rotary-drum laundry dryer (1), according to anyone of the foregoing Claims, **characterized in that** its rear wall (2b) comprises a supporting bulkhead (14a) made of plastic material; at least a portion (142) of a centrifugal impeller scroll (150) made also of plastic material being carried out in one piece with said supporting bulkhead (14a); and/or at least one supporting boss (155) of a drum supporting roller (8) being also made of plastic material and carried out in one piece with said supporting bulkhead (14a).
  12. Rotary-drum laundry dryer (1), according to anyone of the foregoing Claims, **characterized in that** the rear wall (2b) of the dryer comprises said supporting bulkhead (14a) made of plastic material; at least one supporting boss (155) of a drum supporting roller (8) being also made of plastic material and carried out in one piece with said supporting bulkhead (14a); and at least one supporting boss (155a) of a supporting roller (8) being carried out in one piece with a lower supporting basement or socle (11).
  13. Rotary-drum laundry dryer, according to anyone of the foregoing Claims, **characterized in that** the rear wall (2b) comprises a circular groove (144) for accommodating a sealing gasket (10).
  14. Rotary-drum laundry dryer, according to anyone of the foregoing Claims, **characterized in that** the rear wall (2b) comprises a cover (14b) which couples with the rear surface of the bulkhead (14a).
  15. Rotary-drum laundry dryer, according to anyone of the foregoing Claims, **characterized in that** said hot-air generator (6) comprises a heat-pump.

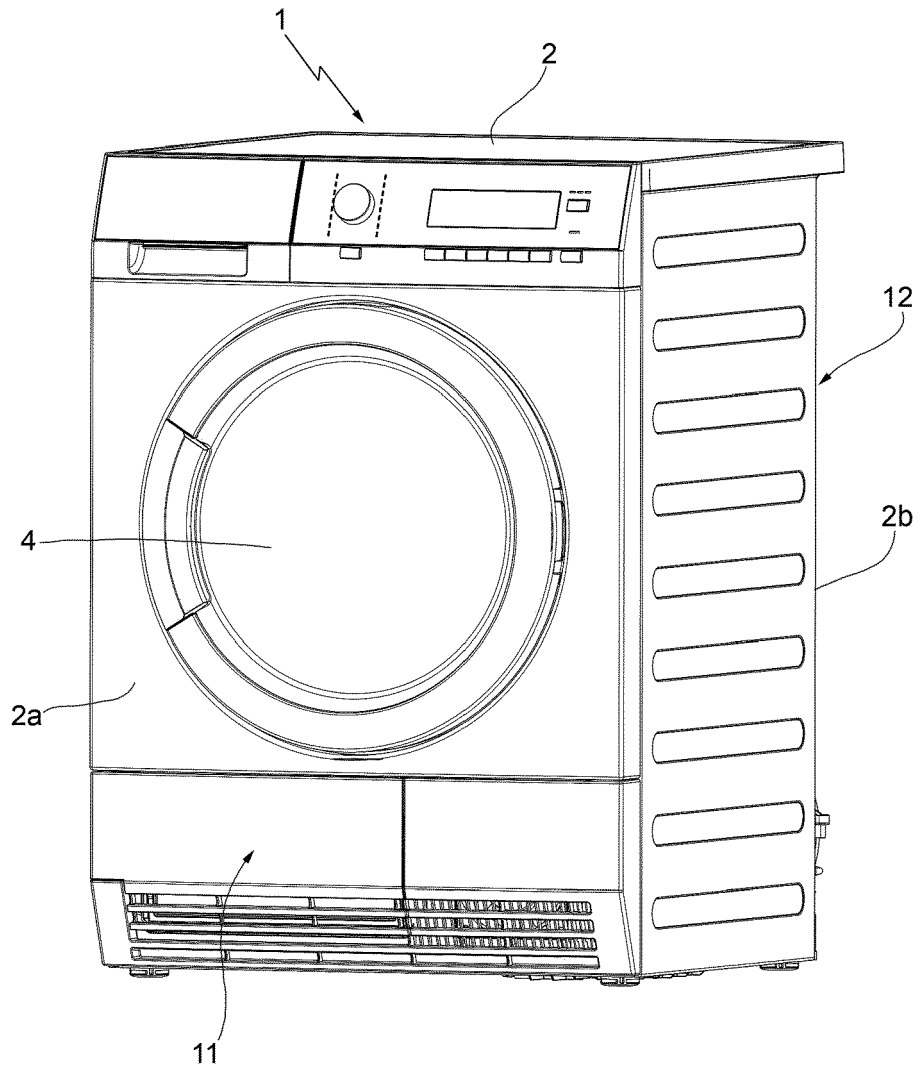
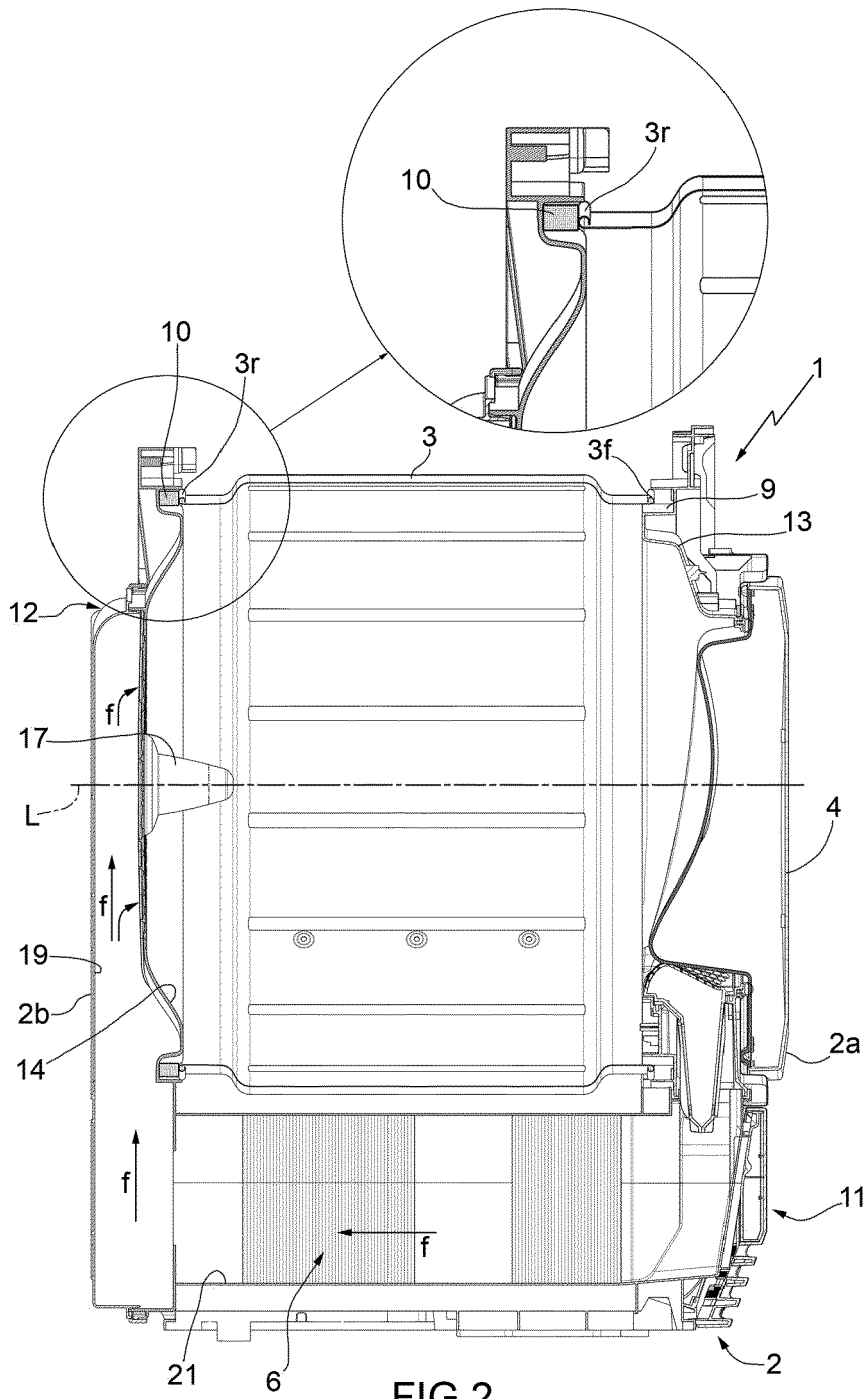

FIG.1





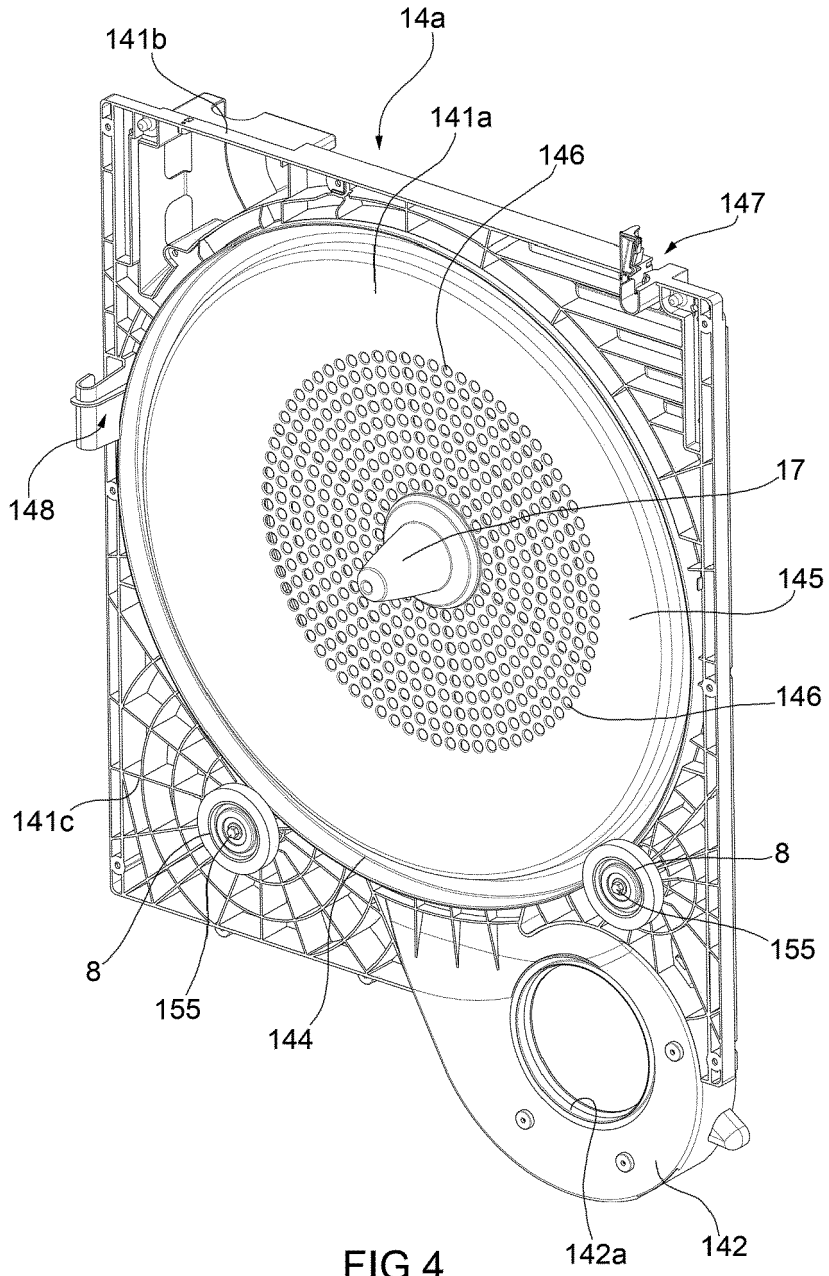

FIG.4

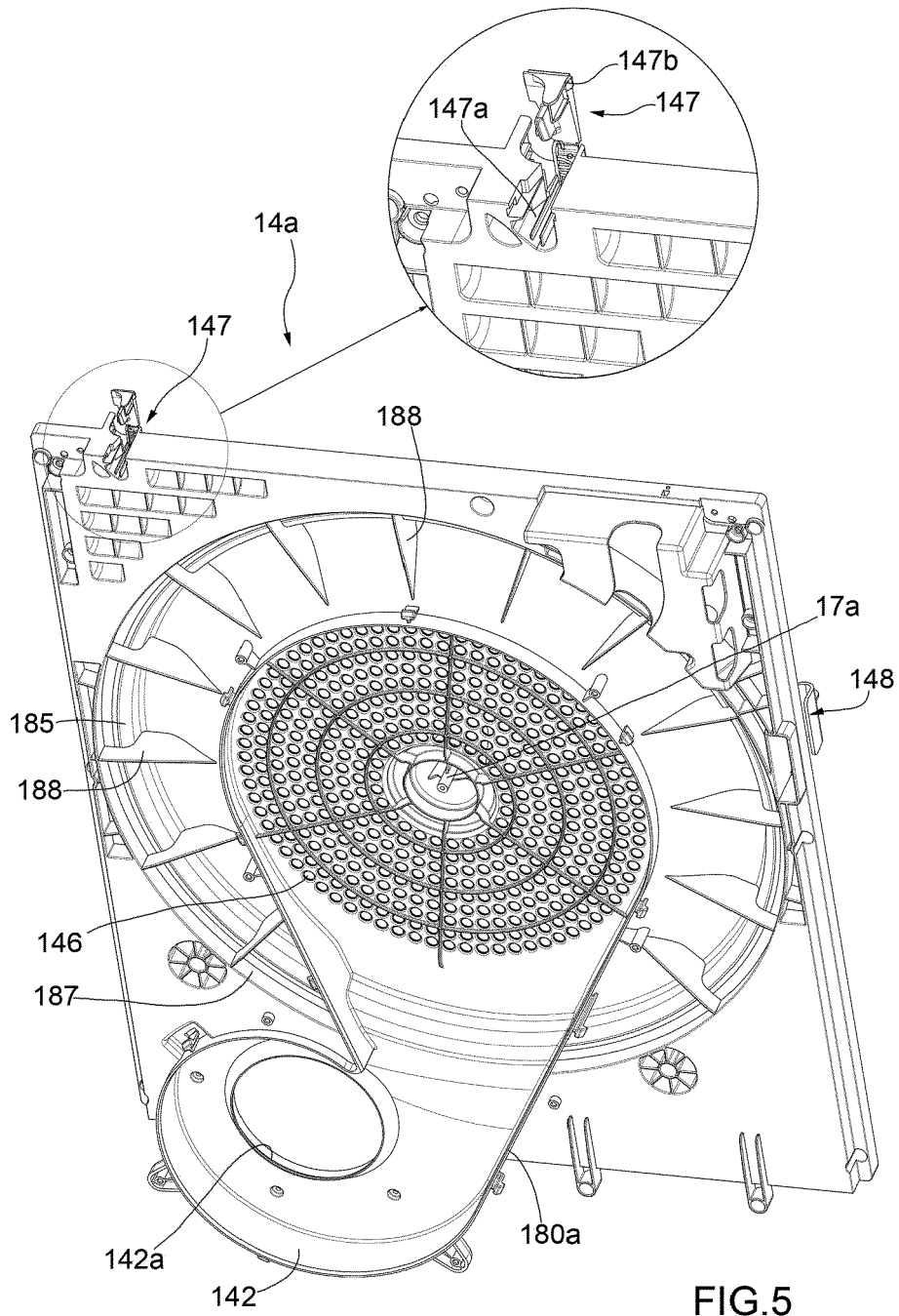

FIG.5

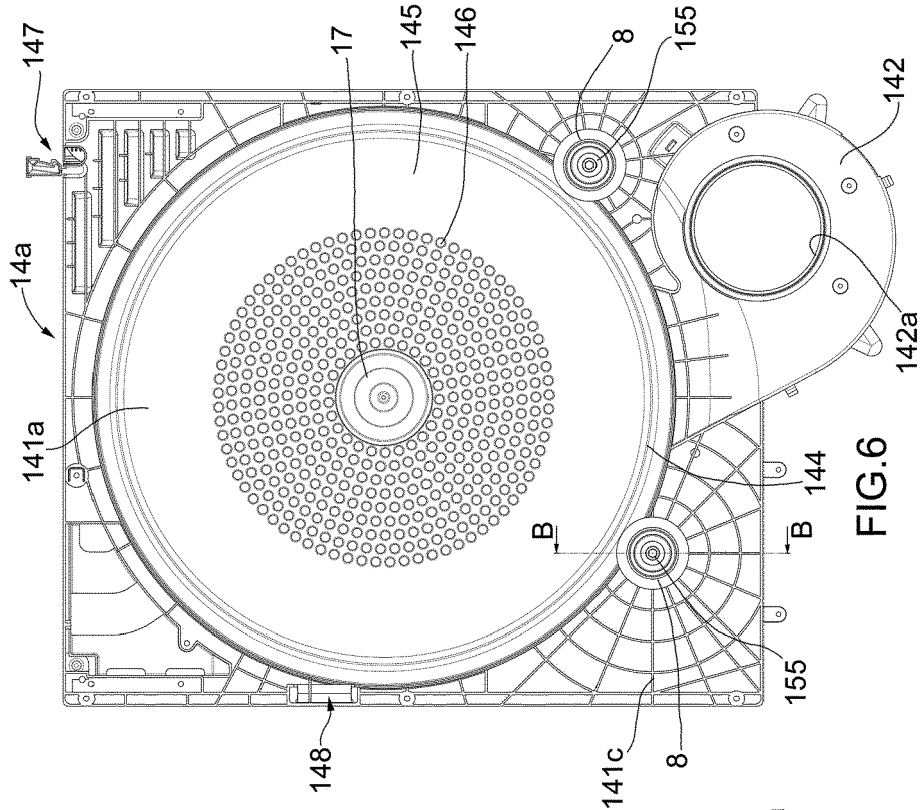

FIG. 6

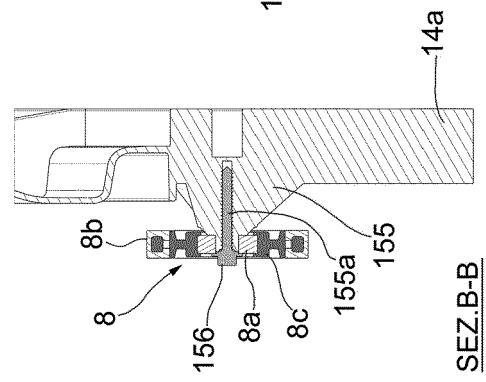

FIG. 7

SEZ. B-B



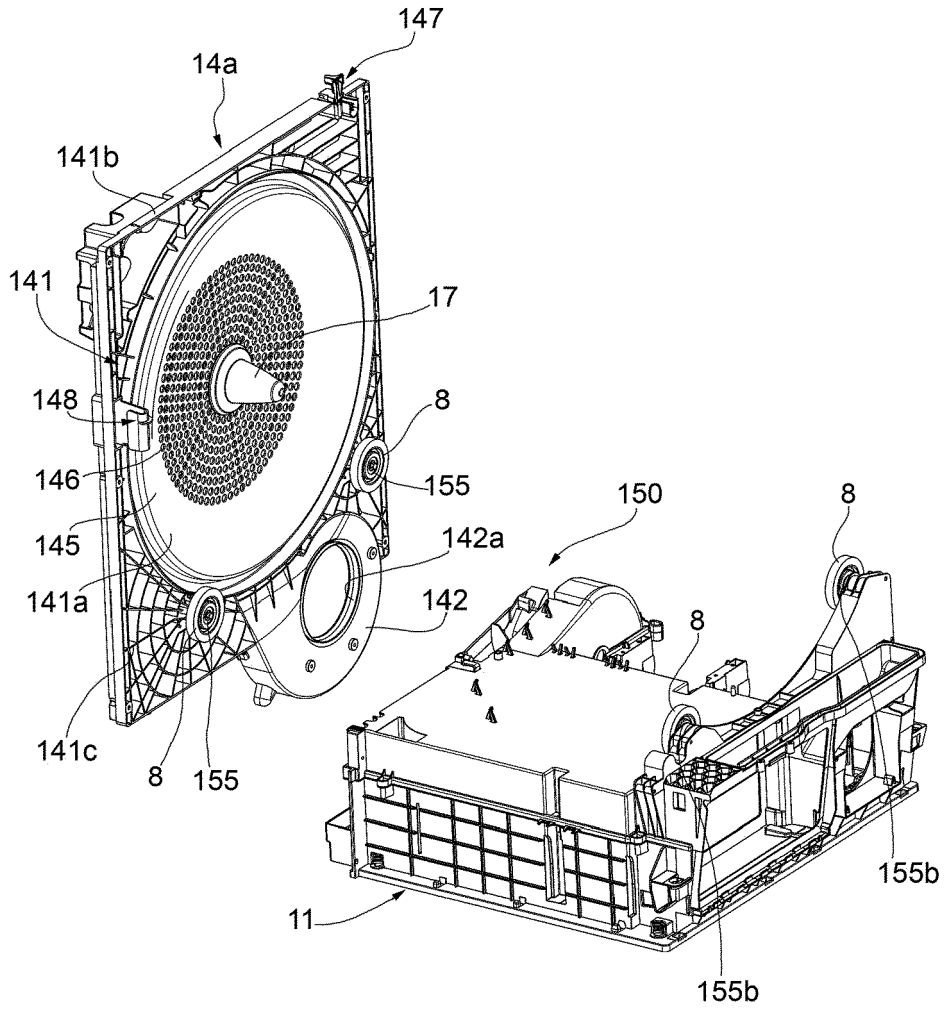

FIG.9

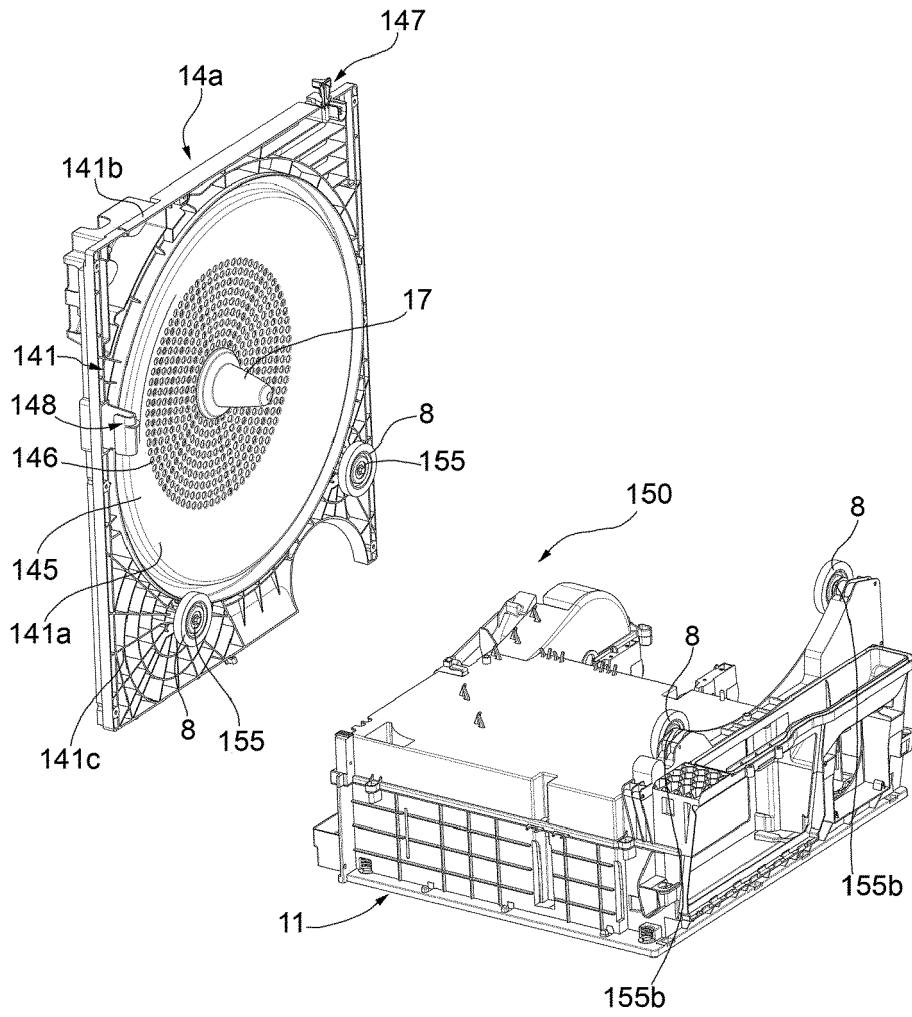

FIG.10

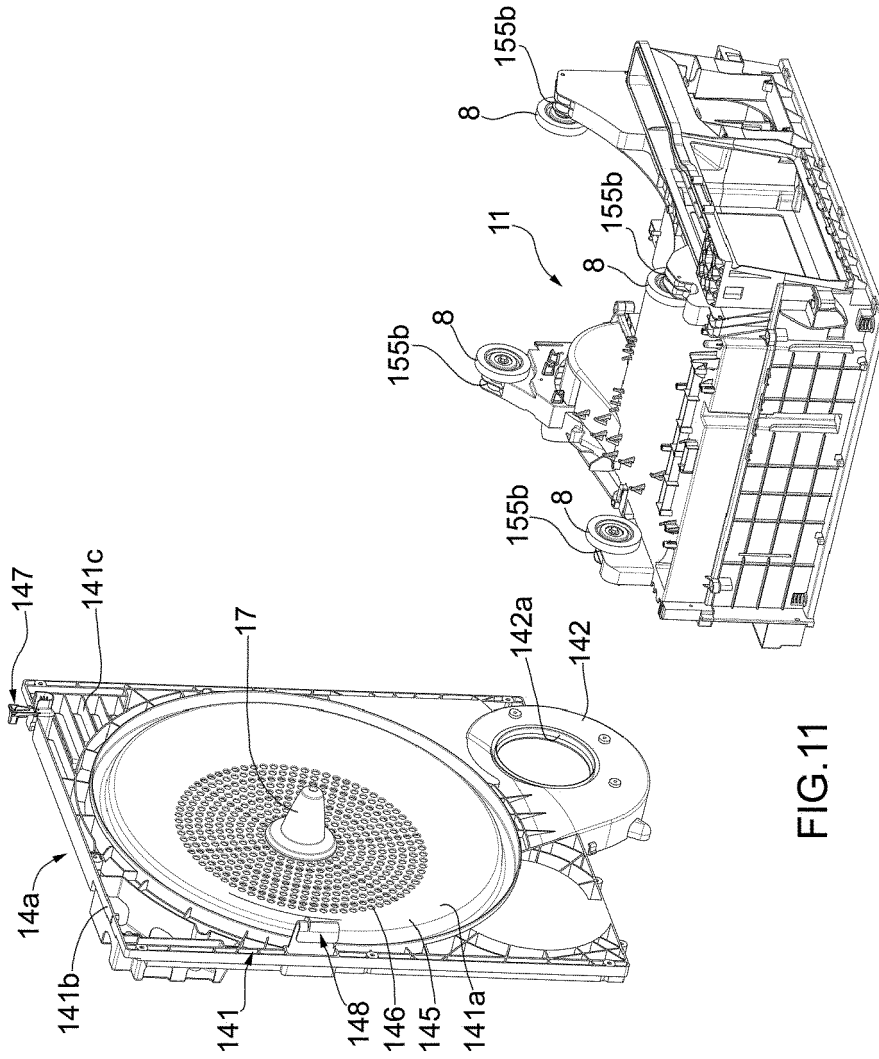

FIG.11



EUROPEAN SEARCH REPORT

Application Number  
EP 13 18 1859

5

10

15

20

25

30

35

40

45

50

55

DOCUMENTS CONSIDERED TO BE RELEVANT			
Category	Citation of document with indication, where appropriate, of relevant passages	Relevant to claim	CLASSIFICATION OF THE APPLICATION (IPC)
X	DE 10 2005 013049 A1 (BSH BOSCH SIEMENS HAUSGERAETE [DE]) 21 September 2006 (2006-09-21)	1	INV. D06F58/20 D06F58/04 D06F58/06
Y	* paragraphs [0007] - [0011] * * paragraphs [0016] - [0021] * * claims 1-9; figures 1-2 *	2-15	
Y	EP 2 527 523 A1 (ELECTROLUX HOME PROD CORP [BE]) 28 November 2012 (2012-11-28) * paragraphs [0052] - [0057] * * figures 1-6 *	2,3,11,15	
Y	EP 2 592 184 A1 (ELECTROLUX HOME PROD CORP [BE]) 15 May 2013 (2013-05-15) * paragraphs [0037] - [0049] * * figures 1-5 *	4,6,7,14	
Y	WO 2010/076128 A1 (ARCELIK AS [TR]; ATAY CANYIGIT [TR]; BATUR ALPER [TR]; CETINKAYA ERTAN) 8 July 2010 (2010-07-08) * paragraphs [0030] - [0042] * * figures 1-10 *	5,12	
Y	EP 2 072 657 A1 (BSH BOSCH SIEMENS HAUSGERAETE [DE]) 24 June 2009 (2009-06-24) * paragraphs [0002] - [0012] * * abstract; figures 1,2 *	13	
Y	WO 2011/080114 A1 (ARCELIK AS [TR]; GULBAY UMIT [TR]; CINAR LEVENT [TR]; CAN REMZI [TR]) 7 July 2011 (2011-07-07) * paragraphs [0022] - [0023] * * abstract; figures 1-9 *	8-10	TECHNICAL FIELDS SEARCHED (IPC)
A	KR 2006 0120756 A (LG ELECTRONICS INC [KR]) 28 November 2006 (2006-11-28) * abstract; figures 6,7 *	1	D06F
The present search report has been drawn up for all claims			
Place of search Munich		Date of completion of the search 7 February 2014	Examiner Weinberg, Ekkehard
CATEGORY OF CITED DOCUMENTS X : particularly relevant if taken alone Y : particularly relevant if combined with another document of the same category A : technological background O : non-written disclosure P : intermediate document		T : theory or principle underlying the invention E : earlier patent document, but published on, or after the filing date D : document cited in the application L : document cited for other reasons & : member of the same patent family, corresponding document	

EPC FORM 1503 03.02 (F04C01)



EUROPEAN SEARCH REPORT

Application Number  
EP 13 18 1859

5

10

15

20

25

30

35

40

45

50

55

DOCUMENTS CONSIDERED TO BE RELEVANT			
Category	Citation of document with indication, where appropriate, of relevant passages	Relevant to claim	CLASSIFICATION OF THE APPLICATION (IPC)
A	GB 2 190 250 A (ZANUSSI ELETTROMECC ZANUSSI ELETTROMECC [IT]; SOLE SPA [IT]) 11 November 1987 (1987-11-11) * page 1, lines 43-53; figure 1 * * page 1, lines 96-107; figure 2 * -----	1	
A	EP 2 103 732 A1 (ELECTROLUX HOME PROD CORP [BE]) 23 September 2009 (2009-09-23) * paragraphs [0018] - [0051] * * figures 1-7 * -----	1-15	
The present search report has been drawn up for all claims			TECHNICAL FIELDS SEARCHED (IPC)
Place of search Munich		Date of completion of the search 7 February 2014	Examiner Weinberg, Ekkehard
<b>CATEGORY OF CITED DOCUMENTS</b> X : particularly relevant if taken alone Y : particularly relevant if combined with another document of the same category A : technological background O : non-written disclosure P : intermediate document		T : theory or principle underlying the invention E : earlier patent document, but published on, or after the filing date D : document cited in the application L : document cited for other reasons ..... & : member of the same patent family, corresponding document	

EPC FORM 1503 03.82 (F04C01)

ANNEX TO THE EUROPEAN SEARCH REPORT  
ON EUROPEAN PATENT APPLICATION NO.

EP 13 18 1859

5

This annex lists the patent family members relating to the patent documents cited in the above-mentioned European search report.  
The members are as contained in the European Patent Office EDP file on  
The European Patent Office is in no way liable for these particulars which are merely given for the purpose of information.

07-02-2014

10

15

20

25

30

35

40

45

50

55

Patent document cited in search report	Publication date	Patent family member(s)	Publication date
DE 102005013049 A1	21-09-2006	AT 412080 T	15-11-2008
		DE 102005013049 A1	21-09-2006
		EP 1871944 A1	02-01-2008
		US 2008104862 A1	08-05-2008
		WO 2006097367 A1	21-09-2006
-----			
EP 2527523 A1	28-11-2012	NONE	
-----			
EP 2592184 A1	15-05-2013	NONE	
-----			
WO 2010076128 A1	08-07-2010	EP 2376701 A1	19-10-2011
		WO 2010076128 A1	08-07-2010
-----			
EP 2072657 A1	24-06-2009	AT 497049 T	15-02-2011
		DE 102007061983 A1	25-06-2009
		EP 2072657 A1	24-06-2009
-----			
WO 2011080114 A1	07-07-2011	EP 2519682 A1	07-11-2012
		WO 2011080114 A1	07-07-2011
-----			
KR 20060120756 A	28-11-2006	NONE	
-----			
GB 2190250 A	11-11-1987	DE 8706050 U1	19-06-1987
		FR 2598445 A3	13-11-1987
		GB 2190250 A	11-11-1987
		IT 211132 Z2	13-02-1989
-----			
EP 2103732 A1	23-09-2009	EP 2103732 A1	23-09-2009
		EP 2476795 A1	18-07-2012
		RU 2009110047 A	27-09-2010
-----			