



(11) **EP 2 843 133 B9**

(12) **CORRECTED EUROPEAN PATENT SPECIFICATION**

(15) Correction information:  
**Corrected version no 1 (W1 B1)**  
**Corrections, see**  
**Description Paragraph(s) 5**

(51) Int Cl.:  
**E02B 3/26 (2006.01)**

(86) International application number:  
**PCT/JP2013/062060**

(48) Corrigendum issued on:  
**20.06.2018 Bulletin 2018/25**

(87) International publication number:  
**WO 2013/161874 (31.10.2013 Gazette 2013/44)**

(45) Date of publication and mention  
of the grant of the patent:  
**21.02.2018 Bulletin 2018/08**

(21) Application number: **13782509.7**

(22) Date of filing: **24.04.2013**

---

(54) **PNEUMATIC FENDER**

PNEUMATISCHER KOTFLÜGEL

DÉFENSE PNEUMATIQUE

---

(84) Designated Contracting States:  
**AL AT BE BG CH CY CZ DE DK EE ES FI FR GB**  
**GR HR HU IE IS IT LI LT LU LV MC MK MT NL NO**  
**PL PT RO RS SE SI SK SM TR**

- **KANEKO, Michito**  
**Hiratsuka-shi**  
**Kanagawa 254-8601 (JP)**
- **IZUMI, Minami**  
**Hiratsuka-shi**  
**Kanagawa 254-8601 (JP)**

(30) Priority: **27.04.2012 JP 2012103284**

(43) Date of publication of application:  
**04.03.2015 Bulletin 2015/10**

(74) Representative: **Dilg, Haeusler, Schindelmann**  
**Patentanwaltsgesellschaft mbH**  
**Leonrodstrasse 58**  
**80636 München (DE)**

(73) Proprietor: **The Yokohama Rubber Co., Ltd.**  
**Minato-ku**  
**Tokyo 105-8685 (JP)**

(56) References cited:  
**JP-A- H0 633 433 JP-A- S5 526 310**  
**JP-A- S6 051 211 JP-A- H05 286 053**  
**JP-A- H05 286 053 JP-A- 2006 272 784**  
**JP-A- 2006 291 628 JP-A- 2008 115 625**

(72) Inventors:  
• **YAMADA, Shu**  
**Hiratsuka-shi**  
**Kanagawa 254-8601 (JP)**  
• **SAKAKIBARA, Shigeki**  
**Hiratsuka-shi**  
**Kanagawa 254-8601 (JP)**

**EP 2 843 133 B9**

---

Note: Within nine months of the publication of the mention of the grant of the European patent in the European Patent Bulletin, any person may give notice to the European Patent Office of opposition to that patent, in accordance with the Implementing Regulations. Notice of opposition shall not be deemed to have been filed until the opposition fee has been paid. (Art. 99(1) European Patent Convention).

## Description

### TECHNICAL FIELD

**[0001]** The present invention relates to a pneumatic fender, and more particularly relates to a pneumatic fender that is capable of being greatly enlarged during use compared with when it is not being used, such as during storage, transport, and the like.

### BACKGROUND ART

**[0002]** A pneumatic fender is used, for example, when transferring crude oil between two adjacent ships, the pneumatic fender is installed between the two hulls to prevent contact between the hulls. Alternatively it is installed on a quay wall or the like, to prevent contact between the quay wall or the like and a ship's hull. In recent years ships' hulls are getting larger and the sea conditions are becoming more severe, so there is a demand for large (large diameter) pneumatic fenders with excellent impact performance.

**[0003]** Pneumatic fenders normally have a cylindrical-shaped body portion with bowl-shaped mirror-sections provided at both ends, and the body portion has a laminated configuration with a plurality of reinforcing layers between inner layer rubber and outer layer rubber. The reinforcing layers are cord layers formed by arranging a plurality of cords in parallel, and the cords are disposed at a predetermined cord angle with respect to the axial direction of the cylinder. The cords of reinforcing layers that are laminated adjacent to each other are disposed so that they intersect (for example, see Patent Documents 1, 2). Conventionally the cord angle is set to a static angle of about (54° to 55°) in an uninflated neutral state, so even when the interior of the pneumatic fender is filled with air to the prescribed internal pressure, its size (length and external diameter) does not change much.

**[0004]** In this case, if the pneumatic fender is simply made larger in order to increase the impact performance, its handleability when it is not being used, such as in storage, transport, and installation, is significantly reduced. Specifically, wide space is needed to store the pneumatic fender. Also, a large transport ship is necessary to transport it to its place of installation, and the lifting device such as a crane or the like must also be large. Also, during transport and installation it is difficult to move, so much effort is required. Therefore a pneumatic fender that is compact when not being used, and that greatly expands as much as possible when it is being used is desirable.

### PRIOR ART DOCUMENTS

#### Patent Documents

**[0005]**

Patent Document 1: Japanese Unexamined Patent Application Publication No. H5-286053, which is considered the closest prior art document.

Patent Document 2: Japanese Unexamined Patent Application Publication No. 2003-129446

### SUMMARY OF THE INVENTION

#### Problems to be Solved by the Invention

**[0006]** It is an object of the present invention to provide a pneumatic fender that is capable of being greatly enlarged during use compared with when it is not being used, such as during storage, transport, and the like

#### Means to Solve the Problem

**[0007]** In order to achieve the above object, the pneumatic fender according to the present invention comprises the features of claim 1.

#### Effect of the Invention

**[0008]** According to the present invention, in the uninflated neutral state the intermediate rubber layers whose thicknesses are 1 mm to 5 mm are interposed between each of the reinforcing layers, the cords of reinforcing layers that are laminated adjacent to each other intersect and have a cord angle that is set to 15° to 45° with respect to the body axial direction, so when the fender is filled with air to the prescribed internal pressure, the cord angle increases to a stable static angle. In this case each of the intermediate rubber layers deforms in shear, so the cord angle increases smoothly up to the static angle. Therefore although the fender is compact when not in use, during use it is possible to greatly expand the diameter of the body portion. If the thickness of the intermediate rubber layer in the neutral state is less than 1 mm, the shear force between layers during inflation becomes excessive, so adverse effects such as reduction in durability and inter-layer separation and the like can easily occur.

**[0009]** In this case, if the 100% modulus of the rubber of the intermediate rubber layers is 0.5 MPa to 5.0 MPa, the diameter of the body portion can be stably increased sufficiently.

**[0010]** Also, if the 100% modulus of the rubber of the intermediate rubber layers is less than 0.5 MPa, time is required for the body portion to shrink, and there is a possibility that the body portion will not return to its original diameter. On the other hand, if it exceeds 5.0 MPa, the shear force in the intermediate rubber layers increases when inflating, so they have difficulty deforming and it is difficult to expand the diameter of the body portion sufficiently.

**[0011]** It is possible to specify that in the uninflated neutral state, the thickness of the intermediate rubber layers increases towards the outer circumferential side. When

inflating the body portion, a greater shear deformation is necessary in the intermediate rubber layers towards the outer side, so this specification has the advantage that it is possible to prevent an excessive load being produced in some of the intermediate rubber layers.

**[0012]** Also, in the uninflated neutral state, the external diameter of the body portion is, for example, 3 m to 5 m. With the external diameter in this range handling when the fender is not in use such as during storage or transport, and the like, is comparatively easy.

#### BRIEF DESCRIPTION OF THE DRAWINGS

##### **[0013]**

FIG. 1 is an explanatory view showing a side view partially sectioned of a reinforcing layer of the body portion of a pneumatic fender according to the present invention when it is not inflated;

FIG. 2 is an explanatory view showing a front view of the reinforcing layer of the mirror section of the pneumatic fender in FIG. 1;

FIG. 3 is a partial enlarged cross-sectional view of the body portion of the pneumatic fender in FIG. 1; and

FIG. 4 is an explanatory view showing a side view partially sectioned of a reinforcing layer of the body portion of the pneumatic fender in FIG. 1 when it is inflated.

#### BEST MODE FOR CARRYING OUT THE INVENTION

**[0014]** The pneumatic fender according to the present invention is described below, based on the embodiments shown on the drawings.

**[0015]** As shown in FIGS. 1 to 3, a pneumatic fender 1 (hereafter referred to as fender 1) according to the present invention includes a cylindrical-shaped body portion 2 and bowl-shaped mirror sections 3 at both ends thereof. In this embodiment, one mirror section 3 is provided with a fitting 9, but this may also be provided to the mirror sections 3 at both ends.

**[0016]** The body portion 2 has a laminated configuration with a plurality of reinforcing layers 5 between an inner layer rubber 4 and an outer layer rubber 7. In this embodiment, six reinforcing layers 5 (5a to 5f) are laminated. The number of laminations of reinforcing layers 5 is, 6 to 12. An intermediate rubber layer 8 (8a to 8e) is disposed between each of the reinforcing layers 5.

**[0017]** Each of the reinforcing layers 5 is a cord layer formed from a plurality of cords 6a (6b) arranged in parallel. The cords 6a, 6b of adjacent laminated reinforcing layers 5 intersect, and are disposed with a predetermined cord angle A with respect to the cylinder axial direction (cylinder center line CL) of the body portion 2. In other words, the reinforcing layer 5a of the inner peripheral side first layer, the reinforcing layer 5c of the third layer, and the reinforcing layer 5e of the fifth layer have a cord

angle A in the same direction. The reinforcing layer 5b of the inner peripheral side second layer, the reinforcing layer 5d of the fourth layer, and the reinforcing layer 5f of the sixth layer have a cord angle A in the same direction, and, this cord angle A has the opposite orientation to that of the reinforcing layers 5a, 5c, 5e. The cord angle A may be different among a plurality of reinforcing layers 5, and can be set as appropriate depending on the number of laminations of the reinforcing layers 5, or the cords 6a, 6b, the intermediate rubber layers 8, the external diameter of the body portion 2, and the like, as described later.

**[0018]** Steel cords or organic fiber cords or the like can be used as the cords 6a, 6b. The external diameter of the cords 6a, 6b is, for example, about 0.5 mm to 1.5 mm.

**[0019]** The mirror sections 3 have a laminated configuration with a plurality of reinforcing layers between the inner layer rubber 4 and the outer layer rubber 7. A reinforcing layer (cord layer) formed from cords 6c disposed in a radial manner, and a reinforcing layer (cord layer) formed from cords 6d disposed in the circumferential direction are alternately laminated. The specification of the cords 6c, 6d is basically the same as that of the cords 6a, 6b of the reinforcing layers 5 of the body portion 2.

**[0020]** In the present invention, when the fender 1 is uninflated in a neutral state, the thickness of the intermediate rubber layer 8 is 1 mm to 5 mm, and the cord angle A is set to 15° to 45°. The uninflated neutral state is the state in which tension is not substantially produced in the cords 6a, 6b, air is injected into the interior of the fender 1, but the inner pressure is slightly higher than atmospheric pressure (for example, 10 kPa), so the body portion 2 maintains a cylindrical shape and the mirror sections 3 maintain a bowl shape.

**[0021]** In a conventional pneumatic fender, only very thin adhesive rubber is disposed between two reinforcing layers that are adjacent to each other in the radial direction in order to bond them together. In the present invention, a special intermediate rubber layer 8 is interposed in addition to adhesive rubber. For example natural rubber, butyl rubber, styrene butadiene rubber, acrylonitrile butadiene rubber, or the like are used as the rubber forming the intermediate rubber layer 8.

**[0022]** For example natural rubber, butyl rubber, styrene butadiene rubber, acrylonitrile butadiene rubber, or the like are used as the rubber forming the inner layer rubber 4. For example natural rubber, styrene butadiene rubber, acrylonitrile butadiene rubber, ethylene propylene rubber, or the like are used as the rubber forming the outer layer rubber 7. In the neutral state when the fender 1 is not inflated, the thickness of the inner layer rubber 4 is, for example, about 2 mm to 5 mm, and the thickness of the outer layer rubber 7 is, for example, about 3 mm to 12 mm.

**[0023]** When the fender 1 is not being used, such as during storage, transport, and installation, the internal pressure is reduced to, for example, about 10 kPa to the neutral state in which it is not inflated. Alternatively, the

internal air is discharged and it is folded. When the fender 1 is installed and used at the actual installation site, the interior is filled with air via a valve fitted to the fitting 9, to the prescribed internal pressure. The prescribed internal pressure is, for example, 50 kPa to 100 kPa.

**[0024]** In the process of filling the interior of the fender 1 with air to the prescribed internal pressure, the cord angle A of the cords 6a, 6b of each of the reinforcing layers 5 increases to a stable static angle (54° to 55°). In this case, the thickness of the intermediate rubber layers 8 in the neutral state is 1.0 mm or more, so each of the intermediate rubber layers 8 deforms in shear appropriately. As a result, as shown in FIG. 4, the cord angle A varies smoothly up to the static angle, so during use the body portion 2 can inflate and increase in diameter greatly.

**[0025]** For example, the external diameter of the body portion 2 can increase by about 150% to 250% during use relative to the neutral state. The length in the axial direction of the fender 1 (body portion 2) can increase by 95% to 60% during use relative to the neutral state.

**[0026]** If the thickness of the intermediate rubber layer 8 is less than 1 mm, it is difficult to deform in shear sufficiently when the fender 1 is inflated. If the thickness of the intermediate rubber layer 8 exceeds 5 mm, the mass of the fender 1 is excessive.

**[0027]** Also, if the cord angle A in the neutral state is less than 15°, excessive shear stress is produced in the intermediate rubber layer 8 to increase the cord angle A to the static angle. If the cord angle A exceeds 45°, the increase in the diameter of the body portion 2 when the prescribed internal pressure is applied from the neutral state is small. In other words, when the cord angle A exceeds 45°, the external diameter of the fender 1 when it is not being used is not very small.

**[0028]** It has also been confirmed that even if the cord angle A in the uninflated neutral state is 15° to 45°, if the thickness of the intermediate rubber layers 8 is less than 1 mm, there is very little increase in the diameter of the body portion 2 when the prescribed internal pressure is applied. In other words, by appropriately setting the cord angle A and the thickness of the intermediate rubber layer 8 in the uninflated neutral state of the fender 1 according to the present invention, the fender 1 is compact in the neutral state when it is not being used, and the diameter of the body portion 2 can increase greatly when it is being used.

**[0029]** In this way, it is possible to reduce the storage space of the fender 1. Also, it is not necessary to provide a large transport ship or transport vehicle to transport the fender 1 to the installation location, and a large crane device or the like need not be used for lifting. The fender 1 is easier to move during transport and installation, so these operations are easier. In this way, the handlability of the fender 1 when it is not being used (when it is not inflated) is improved.

**[0030]** Preferably the 100% modulus of the rubber forming the intermediate rubber layers 8 is 0.5 MPa to

5.0 MPa. If the 100% modulus of the intermediate rubber layers 8 is less than 0.5 MPa, time is required for the body portion to shrink and reduce the diameter, and there is a possibility that the body portion will not return to its original diameter. On the other hand, if it exceeds 5.0 MPa, the shear force in the intermediate rubber layers increases when inflating, so they have difficulty deforming and it is difficult to expand the diameter of the body portion sufficiently.

**[0031]** In this embodiment, in the uninflated neutral state, the thicknesses of all the intermediate rubber layers 8 are the same, but it is possible to specify that the thickness of the intermediate rubber layers 8 increases towards the outer circumferential side. When inflating the body portion 2, a greater shear deformation is necessary in the intermediate rubber layers 8 towards the outside, so with this specification it is possible to prevent an excessive load being produced in some of the intermediate rubber layers 8 when inflating the body portion 2.

**[0032]** Also, in the uninflated neutral state, the external diameter of the body portion 2 is, for example, 3 m to 5 m. With the external diameter in this range handling when the fender is not in use such as during storage or transport, and the like, is comparatively easy.

#### Reference Numbers

#### [0033]

- 1 Pneumatic fender
- 2 Body portion
- 3 Mirror section
- 4 Inner layer rubber
- 5, 5a, 5b, 5c, 5d, 5e, 5f Reinforcing layer
- 6a, 6b, 6c, 6d Cord
- 7 Outer layer rubber
- 8, 8a, 8b, 8c, 8d, 8e, 8f Intermediate rubber layer
- 9 Fitting

#### Claims

1. A pneumatic fender (1) comprising mirror sections (3) at the two ends of a cylindrical body portion (2), a plurality of reinforcing layers (5) is laminated between an inner layer rubber (4) and an outer layer rubber (7), the reinforcing layers (5) are cord layers formed by arranging a plurality of cords (6a-6d) in parallel, and the cords (6a-6d) of reinforcing layers (5) that are laminated adjacent to each other intersect with a predetermined cord angle with respect to the body axial direction, wherein an intermediate rubber layer (8) is interposed between each of the reinforcing layers (5), and **characterized in that** the number of the reinforcing layers (5) is 6 to 12, and

in an uninflated neutral state the thicknesses of the intermediate rubber layers (8) is set to 1 mm to 5 mm, and the cord angle is set to 15° to 45°.

2. The pneumatic fender (1) according to claim 1, wherein the 100% modulus of the rubber of the intermediate rubber layers (8) is 0.5 MPa to 5.0 MPa.
3. The pneumatic fender (1) according to claim 1 or 2, wherein the thickness of the intermediate rubber layer (8) in the uninflated neutral state becomes thicker in the intermediate rubber layers (8) on the outer circumferential side.
4. The pneumatic fender (1) according to any of claims 1 to 3, wherein the external diameter of the body portion (2) in the uninflated neutral state is 3 m to 5 m.

#### Patentansprüche

1. Luftfender (1), umfassend Spiegelabschnitte (3) an den zwei Enden eines zylindrischen Körperteils (2), wobei eine Mehrzahl von Verstärkungsschichten (5) zwischen einer Innenkautschukschicht (4) und einer Außenkautschukschicht (7) laminiert ist, die Verstärkungsschichten (5) durch paralleles Anordnen einer Mehrzahl von Cordfäden (6a-6d) gebildete Cordschichten sind, und die Cordfäden (6a-6d) von Verstärkungsschichten (5), die einander benachbart laminiert sind, sich mit einem vorher festgelegten Cordfadenwinkel bezüglich der Axialrichtung des Körpers überschneiden, wobei eine zwischenliegende Kautschukschicht (8) zwischen jeder der Verstärkungsschichten (5) eingefügt ist, und **dadurch gekennzeichnet, dass** die Anzahl der Verstärkungsschichten (5) 6 bis 12 beträgt, und in einem nicht aufgeblasenen Zustand die Dicke der zwischenliegenden Kautschukschichten (8) auf 1 mm bis 5 mm eingestellt ist und der Cordfadenwinkel auf 15° bis 45° eingestellt ist.
2. Luftfender (1) nach Anspruch 1, wobei der 100 %-Modul des Kautschuks der zwischenliegenden Kautschukschichten (8) 0,5 MPa bis 5,0 MPa beträgt.
3. Luftfender (1) nach Anspruch 1 oder 2, wobei die Dicke der zwischenliegenden Kautschukschicht (8) in dem nicht aufgeblasenen neutralen Zustand in den zwischenliegenden Kautschukschichten (8)

auf der Außenumfangsseite dicker wird.

4. Luftfender (1) nach einem der Ansprüche 1 bis 3, wobei der Außendurchmesser des Körperteils (2) in dem nicht aufgeblasenen neutralen Zustand 3 m bis 5 m beträgt.

#### Revendications

1. Défense pneumatique (1) comprenant des parties en miroir (3) aux deux extrémités d'une partie de corps cylindrique (2), une pluralité de couches de renforcement (5) est stratifiée entre un caoutchouc de couche interne (4) et un caoutchouc de couche externe (7), les couches de renforcement (5) sont des couches de câble formées en disposant une pluralité de câbles (6a à 6d) en parallèle et les câbles (6a à 6d) des couches de renforcement (5) qui sont stratifiées de façon adjacente l'une à l'autre se croisent suivant un angle de câble prédéterminé par rapport à la direction axiale du corps, une couche de caoutchouc intermédiaire (8) étant intercalée entre chacune des couches de renforcement (5) et **caractérisée en ce que** le nombre des couches de renforcement (5) va de 6 à 12 et dans un état neutre non gonflé les épaisseurs des couches de caoutchouc intermédiaires (8) sont définies de 1 mm à 5 mm et l'angle de câble est défini de 15° à 45°.
2. Défense pneumatique (1) selon la revendication 1, dans laquelle le module à 100 % du caoutchouc des couches de caoutchouc intermédiaires (8) va de 0,5 MPa à 5,0 MPa.
3. Défense pneumatique (1) selon la revendication 1 ou 2, dans laquelle l'épaisseur de la couche de caoutchouc intermédiaire (8) dans l'état neutre non gonflé devient plus épaisse dans les couches de caoutchouc intermédiaires (8) sur le côté circonférentiel extérieur.
4. Défense pneumatique (1) selon l'une quelconque des revendications 1 à 3, dans laquelle le diamètre externe de la partie de corps (2) dans l'état neutre non gonflé va de 3 m à 5 m.

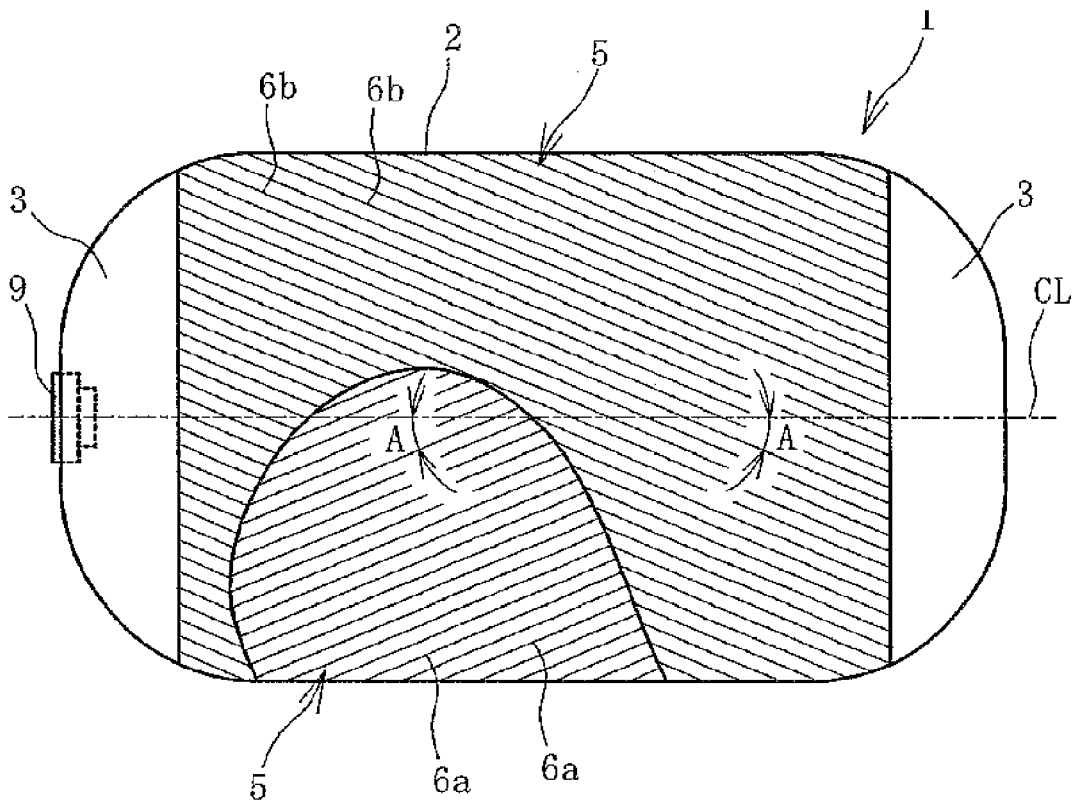

FIG. 1

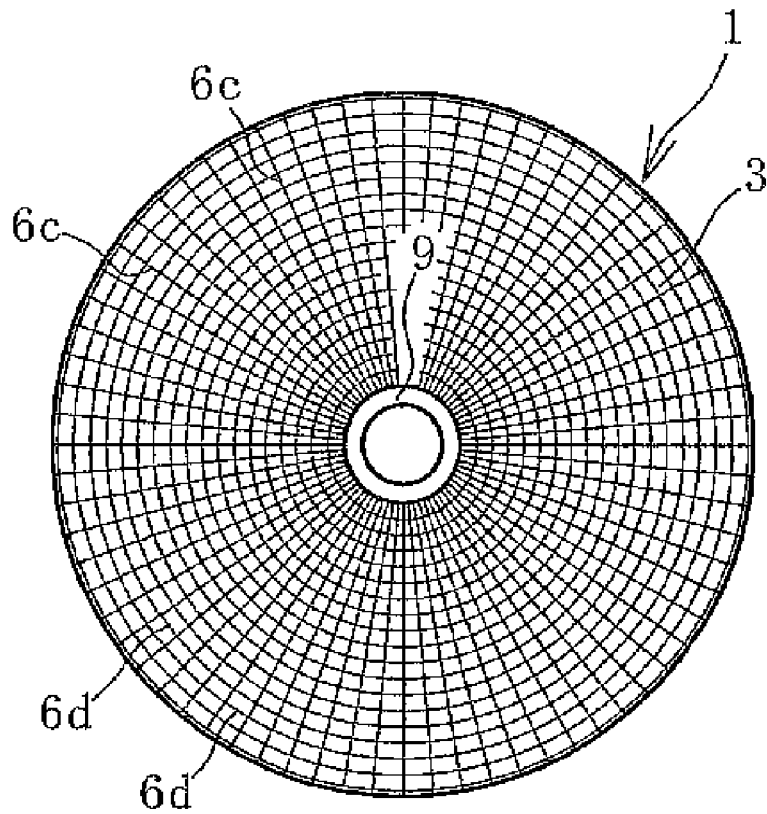

FIG. 2

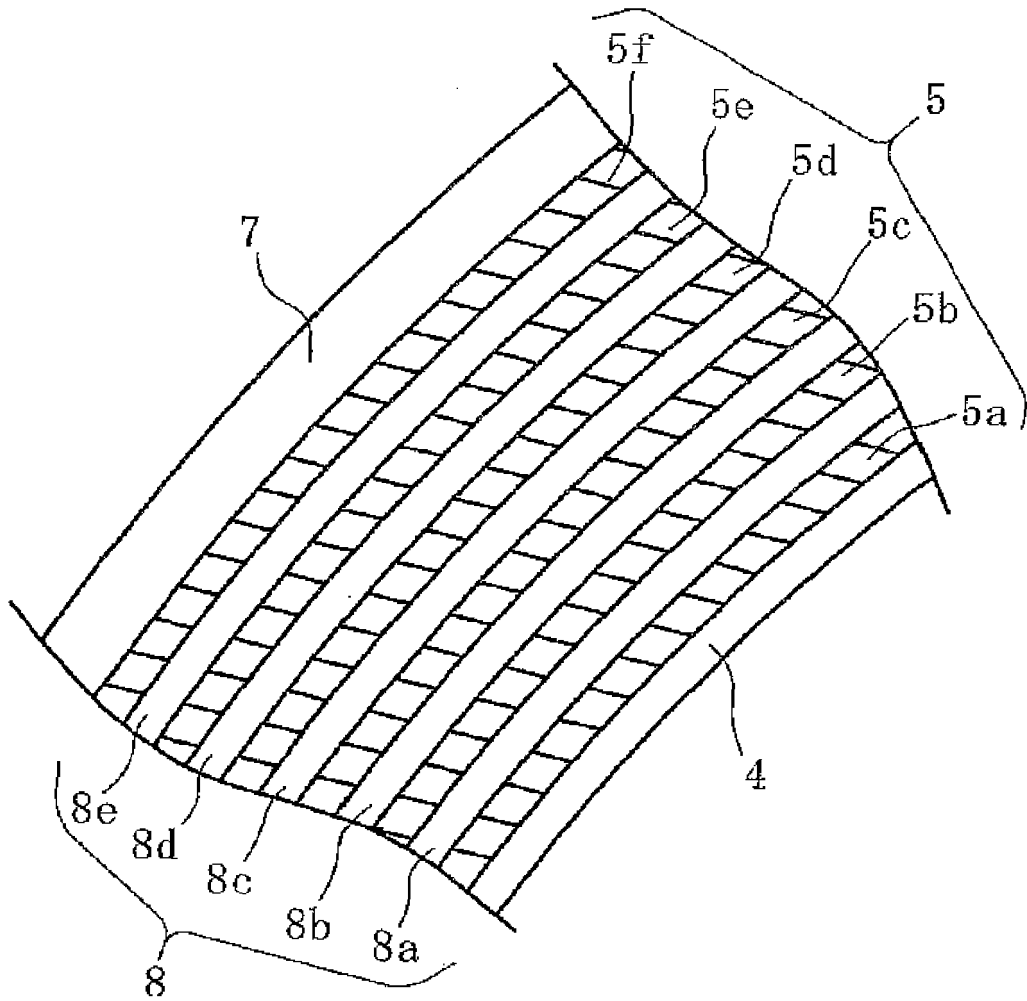

FIG. 3

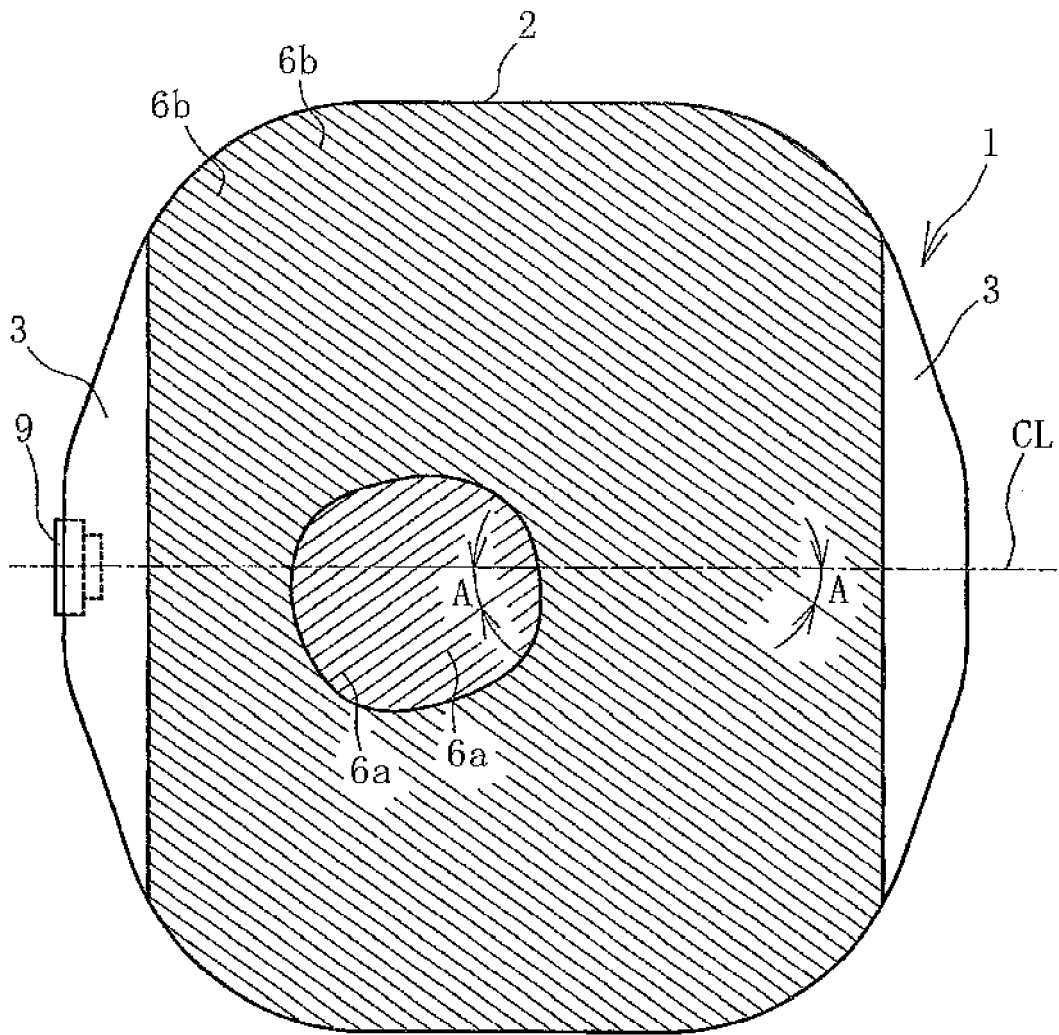

FIG. 4

**REFERENCES CITED IN THE DESCRIPTION**

*This list of references cited by the applicant is for the reader's convenience only. It does not form part of the European patent document. Even though great care has been taken in compiling the references, errors or omissions cannot be excluded and the EPO disclaims all liability in this regard.*

**Patent documents cited in the description**

- JP H5286053 B [0005]
- JP 2003129446 A [0005]