

(19)



(11)

**EP 2 853 174 A3**

(12)

**EUROPEAN PATENT APPLICATION**

(88) Date of publication A3:  
**09.12.2015 Bulletin 2015/50**

(51) Int Cl.:  
**A47B 47/00 (2006.01) E04H 13/00 (2006.01)**  
**E04B 2/74 (2006.01) E04B 1/61 (2006.01)**

(43) Date of publication A2:  
**01.04.2015 Bulletin 2015/14**

(21) Application number: **14169179.0**

(22) Date of filing: **20.05.2014**

(84) Designated Contracting States:  
**AL AT BE BG CH CY CZ DE DK EE ES FI FR GB GR HR HU IE IS IT LI LT LU LV MC MK MT NL NO PL PT RO RS SE SI SK SM TR**  
Designated Extension States:  
**BA ME**

(71) Applicant: **Rivestimenti Plastici S.r.l. Torino (IT)**

(72) Inventor: **Pennazio, Rinaldo 10121 Torino (IT)**

(74) Representative: **Mola, Edoardo et al Studio Torta S.p.A. Via Viotti, 9 10121 Torino (IT)**

(30) Priority: **01.08.2013 IT TO20130656**

**(54) Light prefabricated cell structure**

(57) A prefabricated cell structure comprises a panel (10) having half-shells (11) glued to one another, and channel-section shaped edges (15) obtained by moulding, a clamping sectional element (19) that prismatically couples with two channel-section shaped edges (15) of two panels (10) adjacent at an angle, and at least one

plug (22, 25', 25'') housed between the channel-section shaped edges (15) at one end of two panels (10) adjacent at an angle for closing longitudinally the clamping sectional element (19) in a channel (20) defined by the channel-section shaped edges (15).

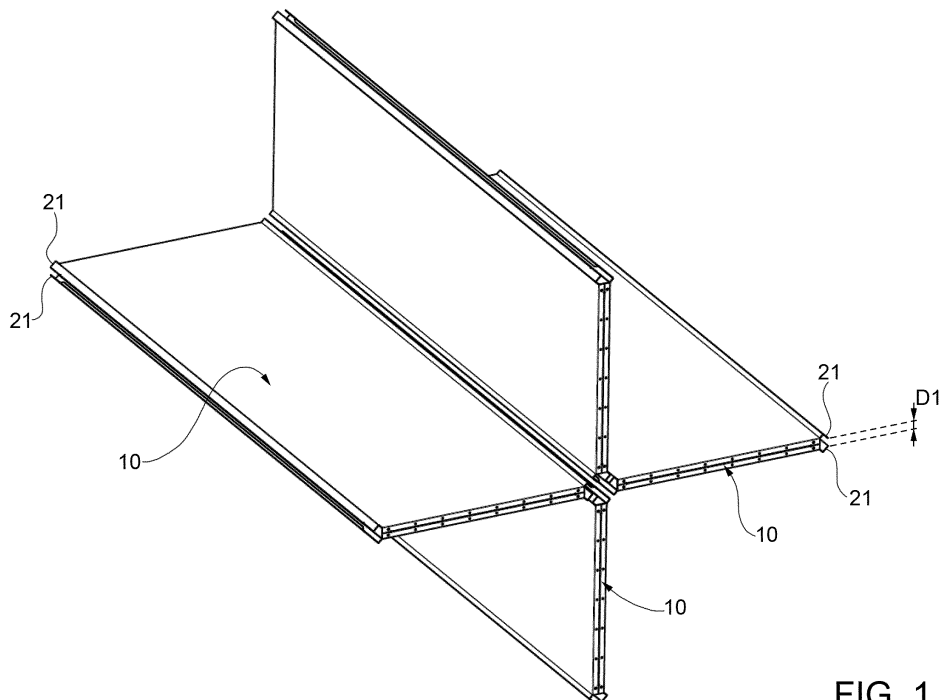

**FIG. 1**

**EP 2 853 174 A3**



EUROPEAN SEARCH REPORT

Application Number  
EP 14 16 9179

5

10

15

20

25

30

35

40

45

50

55

DOCUMENTS CONSIDERED TO BE RELEVANT			
Category	Citation of document with indication, where appropriate, of relevant passages	Relevant to claim	CLASSIFICATION OF THE APPLICATION (IPC)
A	US 3 466 777 A (WISTRAND JOHN C ET AL) 16 September 1969 (1969-09-16) * the whole document * -----	1-10	INV. A47B47/00 E04H13/00 E04B2/74 E04B1/61
A	US 4 601 145 A (WILCOX ROGER [US]) 22 July 1986 (1986-07-22) * the whole document * -----	1-10	
A	US 4 545 142 A (WHISNANT HUBERT E [US]) 8 October 1985 (1985-10-08) * the whole document * -----	1-10	
A	US 5 381 845 A (RUGGIE MARK A [US] ET AL) 17 January 1995 (1995-01-17) * the whole document * -----	1-10	
The present search report has been drawn up for all claims			TECHNICAL FIELDS SEARCHED (IPC)
			A47B E04B E04H
Place of search		Date of completion of the search	Examiner
Munich		2 November 2015	Valenta, Ivar
CATEGORY OF CITED DOCUMENTS		T : theory or principle underlying the invention E : earlier patent document, but published on, or after the filing date D : document cited in the application L : document cited for other reasons ..... & : member of the same patent family, corresponding document	
X : particularly relevant if taken alone Y : particularly relevant if combined with another document of the same category A : technological background O : non-written disclosure P : intermediate document			

1  
EPO FORM 1503 03.02 (F04C01)

**ANNEX TO THE EUROPEAN SEARCH REPORT  
ON EUROPEAN PATENT APPLICATION NO.**

EP 14 16 9179

5

This annex lists the patent family members relating to the patent documents cited in the above-mentioned European search report. The members are as contained in the European Patent Office EDP file on  
The European Patent Office is in no way liable for these particulars which are merely given for the purpose of information.

02-11-2015

10

Patent document cited in search report		Publication date	Patent family member(s)	Publication date
US 3466777	A	16-09-1969	NONE	
-----				
US 4601145	A	22-07-1986	NONE	
-----				
US 4545142	A	08-10-1985	NONE	
-----				
US 5381845	A	17-01-1995	NONE	
-----				

15

20

25

30

35

40

45

50

55

EPO FORM P0459

For more details about this annex : see Official Journal of the European Patent Office, No. 12/82