

(19)



(11)

EP 2 853 846 B1

(12)

EUROPEAN PATENT SPECIFICATION

(45) Date of publication and mention of the grant of the patent:
26.10.2016 Bulletin 2016/43

(51) Int Cl.:
F25D 3/10 ^(2006.01) **F25D 31/00** ^(2006.01)
B65D 83/28 ^(2006.01) **A47G 19/22** ^(2006.01)

(21) Application number: **14167556.1**

(22) Date of filing: **08.05.2014**

(54) Device for coating containers

Vorrichtung zum Beschichten von Behälter

Dispositif de revêtement DE RÉCIPIENTS

(84) Designated Contracting States:
AL AT BE BG CH CY CZ DE DK EE ES FI FR GB GR HR HU IE IS IT LI LT LU LV MC MK MT NL NO PL PT RO RS SE SI SK SM TR

(30) Priority: **08.05.2013 ES 201330549 U**

(43) Date of publication of application:
01.04.2015 Bulletin 2015/14

(73) Proprietors:

- **Sarasola Otegui, Xabier**
20240 Ordizia, Guipuzkoa (ES)
- **Sarasola Otegui, Ignacio Maria**
20240 Ordizia, Guipuzkoa (ES)

(72) Inventors:

- **Sarasola Otegui, Xabier**
20240 Ordizia, Guipuzkoa (ES)
- **Sarasola Otegui, Ignacio Maria**
20240 Ordizia, Guipuzkoa (ES)

(74) Representative: **Pons**
Glorieta Ruben Dario 4
28010 Madrid (ES)

(56) References cited:
FR-A1- 2 880 104 US-A- 3 383 879
US-A- 3 407 624 US-A- 5 671 604

EP 2 853 846 B1

Note: Within nine months of the publication of the mention of the grant of the European patent in the European Patent Bulletin, any person may give notice to the European Patent Office of opposition to that patent, in accordance with the Implementing Regulations. Notice of opposition shall not be deemed to have been filed until the opposition fee has been paid. (Art. 99(1) European Patent Convention).

Description**OBJECT OF THE INVENTION**

[0001] The present invention relates to the field of generating at least partially crystalline textured surfaces.

[0002] The object of the invention is a device that allows the deposition of a layer of ice or frost on the outer / inner surface of a container.

BACKGROUND OF THE INVENTION

[0003] Frosting is known in the presentation and preparation of containers as a technique for the generation of a thin layer of ice or frost on the surface thereof.

[0004] Such operations are commonly used in catering in which containers such as bottles are usually sprayed with water, then placing the bottles in a freezer so that the liquid layer which coats the outer bottle surface, upon coming into contact with a very low temperature, close to or beyond water solidification temperature, change its state whereby the layer of water becomes a thin layer of ice, generally uneven, namely frost.

[0005] This process is carried out manually and said change of state from water to frost takes a long time.

[0006] A solution to this problem appeared in the form of machines and methods that use various types of gases, having cryogenic characteristics and further not affecting humans as they are not harmful; this is an important issue given the destination of the container once the frost layer is applied on the outside.

[0007] A device for chilling a glass is disclosed in FR2880104, where a glass chilling device has removable cover with projection pierced with lateral holes permitting to liberate, upon simple pressure of user, refrigerant gas that invades glass inverted on cover and freezes instantaneously at contact of air. The device disclosed has a double walled case enclosing an aerosol type refrigerant gas container equipped with a spray head on its one end. A removable cover is fitted on the head, and has a projection in its centre which is pierced with lateral holes permitting to liberate, upon a simple pressure of a user, the gas that fills a glass inverted on the cover and freezes instantaneously at the contact of air.

[0008] US 5 671 604 discloses a device for the production of container coatings according to the preamble of claim 1.

[0009] Such machines and methods have an obvious disadvantage, due to the indiscriminate and uncontrolled use of the application of gas and water, so that both are wasted and in addition the production time of said layer of frost is increased.

DESCRIPTION OF THE INVENTION

[0010] To solve the above stated problem a device according to claim 1 is proposed, allowing for the deposition of a layer of ice or frost on the outer surface, inner surface

or both of the container more efficiently.

[0011] For this purpose, the device described herein has a gas diffuser having a given gas nozzle whose configuration which allows the generation of a more uniform frost on the containers to be frosted and in less time; also the coating process is carried out with a lower percentage of gas, about 40% less in the case of using CO₂ since the nozzle has a series of conduits designed and arranged so as to achieve a more efficient result.

[0012] Likewise the device described herein makes use of a water diffuser having characteristics defined by a specific nozzle for spraying the water more efficiently; for this purpose, said nozzle has two joined holes at its end, thereby preventing the nozzle from clogging or from freezing decreasing its spraying capacity.

DESCRIPTION OF THE DRAWINGS

[0013] To complement the description and in order to better understand the characteristics of the invention according to a preferred practical embodiment thereof, a set of drawings are included as an integral part of said description, which by way of illustration and without limiting the scope of the invention, represent the following:

Figure 1 -. Shows a schematic overall view of the device of the invention.

Figure 2 -. Shows a diagram wherein the arrangement of diffusers and their connections are shown.

Figures 3a, 3b, 3c and 3d -. Show different views of the water nozzle.

Figure 4a -. Shows a section of the lower part of the gas nozzle.

Figure 4b -. Show a section of the gas nozzle.

PREFERRED EMBODIMENT OF THE INVENTION

[0014] In view of the figures, a preferred embodiment of the device (1) which is shown in Figure 1 to produce a coating on a container (2) is described below.

[0015] For this purpose, the device (1) is connected, as detailed in Figure 2, to a supply module (10) as a power supply or is equipped with a battery to enable its operation, and both gas supply means (11) and water supply means (12).

[0016] Subsequently, the container (2) is introduced into a receptacle (3) of the device (1) which in turn comprises at least one compartment (4) intended to at least partially house the container (2), which is subjected to the action of a gas diffuser having at least one gas nozzle (7), a water diffuser with at least one water nozzle (5) and a control unit (6) which monitors the diffusers so that spray control means can be implemented by means of solenoid valves connected to said control unit (6), such that a first solenoid valve (13) connected to the gas diffuser and intended to control the flow of gas into said gas diffuser and / or a second solenoid valve (14) connected to the water diffuser and intended to control the flow of

water into said water diffuser and its corresponding nozzles (5,7).

[0017] Upon operation of the gas supply means (11), the gas, preferably CO₂, flows to the gas nozzle (7) shown in longitudinal section in Figure 4b. The gas is preferably pressurized; said pressurization can be carried out by the very gas supply means (11). Once the gas reaches the gas nozzle (7), it enters an essentially solid body (71) with a central blind bore within it through which the gas passes until exiting through two threads (72) which are two cuts 0.35mm in width defined forming 45° with respect to a central longitudinal axis of the body (71) on both sides of a lower section of the body (71) and connecting the outside of the body (71) with the centre bore as shown in Figure 4a, in a preferred embodiment the gas also finds an outlet in the lower part of the body (71), as there is additionally a transverse groove of approximately 0.4mm which connects the outside of the body (71) with the central blind bore inside the body (71) allowing the exit of gas passing through the blind bore to the exterior. Thus it follows that the gas exits through the sides of the body (71) of the gas nozzle (7) and through the lower part thereof.

[0018] The gas supply is coordinated with a water supply being delivered from the water supply means (12); by acting on said water supply means (12), water at a given pressure preferably controlled via said water supply means (12) reaches the water diffuser and the water nozzle (5) where, in view of figures 3a, 3b, 3c and 3d, it is noted that the water enters a block (50) inside which at least two channels (51) are defined, being respectively arranged at an angle relative to a central longitudinal axis of the block (50) starting from an upper part thereof and converging at a point of the lower part of the block (50), channels through which water flows until exiting the block (50) of the water nozzle (5). This is the simplest embodiment thereof, however in a preferred embodiment of the invention wherein it is possible to optimize the coating generation operation described above, the water nozzle (5) has at least one hole (52) defined at the top of the block (50) connecting at least one channel (51) with the exterior of the block (50) such that water goes into said hole (52) before reaching the channels (51); channels (51) that meet at an inner point of the lower part of the block (50), a point from which in a possible embodiment of the invention an orifice (53) originates that reaches the exterior of the block (50), while in an alternative embodiment the channels (51) meet at a point of the block (50) connecting the exterior of the block (50) allowing a channel (51) outlet at their intersection.

[0019] Water may exit from the channel intersection to the exterior as in a possible preferred embodiment, both channels (51) intersect in an overlapping manner such that the intersection of the two channels (51) have a section in common with that of one of channels (51), i.e. two water flows coming respectively from each of the channels (51) converge at an outlet point whose dimensions are equal to those of one of said channels (51); another

possibility is that the outlet point has other dimensions.

Claims

1. Device (1) for the production of container (2) coatings, said device (1) comprising:

a receptacle (3) which comprises at least one compartment (4) intended to at least partially house the container (2),

characterized in that said device comprises:

a gas diffuser having at least one gas nozzle (7), the gas nozzle (7) comprising an essentially solid body (71) with a central blind bore in its 10 interior, body (71) in which two threads (72) are defined on both sides of a lower section of the body (71) connecting the exterior of the body (71) with the central bore, and a water diffuser with at least one water nozzle (5) comprising a block (50) inside which at least two channels (51) are defined, being 15 respectively arranged at an angle relative to a central longitudinal axis of the block (50) starting from an upper part thereof and converging at a point of the lower part of the block (50).

2. Device according to claim 1 **characterized in that** the threads (72) are 20 defined at 45° relative to a central longitudinal axis of the body (71).

3. Device according to claim 1 **characterized in that** the lower part of the body (71) further comprises a transverse groove connecting the exterior of the body (71) with a central blind bore inside the body (71). 25

4. Device according to claim 1 **characterized in that** the threads (72) are 0.35 mm in width.

5. Device according to claim 3 **characterized in that** the transverse groove 30 is 0.4 mm in width.

6. Device according to claim 1 **characterized in that** the water nozzle (5) further comprises at least one hole (52) defined at the top of the block (50) and connecting at least one channel (51) with the exterior of the block (50).

7. Device according to claim 1 or 5 **characterized in that** the channels (51) meet at an interior point of the lower part of the block (50), point from where an orifice (53) originates that reaches the exterior of the block (50).

8. Device according to claim 1 or 5 **characterized in that** the channels (51) meet at a point of the block (50) connecting with the exterior of the block (50) allowing channel (51) outlet at their intersection.
9. Device according to one of claims 1 to 8 **characterized in that** the channels (51) intersect in an overlapping manner creating an intersection having a section in common with that of one of the channels (51).
10. Device (1) according to claim 1 **characterized in that** it comprises a monitoring unit (6) to at least control the diffuser.
11. Device (1) according to claim 1 **characterized in that** it comprises a supply module (10).
12. Device (1) according to claim 1 **characterized in that** it comprises gas supply means (11).
13. Device (1) according to claim 1 **characterized in that** it comprises water supply means (12).
14. Device (1) according to claim 1 **characterized in that** it comprises at least a first solenoid valve (13) connected to the gas diffuser and intended to control the flow of gas into said gas diffuser (7).
15. Device (1) according to claim 1 **characterized in that** it comprises at least a second solenoid valve (14) connected to the water diffuser and intended to control the flow of water into said water diffuser (5).

Patentansprüche

1. Vorrichtung (1) zur Herstellung von Beschichtungen für Behälter (2), wobei die besagte Vorrichtung (1) ein Gefäß (3) umfasst, das mindestens ein Fach (4) zur mindestens teilweisen Aufnahme des Behälters (2) umfasst,
dadurch gekennzeichnet, dass die besagte Vorrichtung Folgendes umfasst:
- einen Gasverteiler mit mindestens einer Gasdüse (7), wobei die Gasdüse (7) einen im Wesentlichen festen Körper (71) mit einem zentralen Sackloch darin umfasst, wobei im Körper (71) an beiden Seiten eines unteren Abschnitts des Körpers (71) zwei Gewinde (72) definiert sind, die das Äußere des Körpers (71) mit dem zentralen Loch verbinden, und
- einen Wasserverteiler mit mindestens einer Wasserdüse (5), die einen Block (50) umfasst, in dessen Innern mindestens zwei Kanäle (51) definiert sind, die jeweils in einem Winkel relativ zu einer zentralen Längsachse des Blocks (50)

angeordnet sind und an einem oberen Teil davon beginnen und an einem Punkt im unteren Teil des Blocks (50) konvergieren.

- 5 2. Vorrichtung nach Anspruch 1, **dadurch gekennzeichnet, dass** die Gewinde (72) 45° relativ zu einer zentralen Längsachse des Körpers (71) definiert sind.
- 10 3. Vorrichtung nach Anspruch 1, **dadurch gekennzeichnet, dass** der untere Teil des Körpers (71) weiterhin eine Querrille umfasst, die das Äußere des Körpers (71) mit einem zentralen Sackloch im Innern des Körpers (71) verbindet.
- 15 4. Vorrichtung nach Anspruch 1, **dadurch gekennzeichnet, dass** die Gewinde (72) 0,35 mm breit sind.
- 20 5. Vorrichtung nach Anspruch 3, **dadurch gekennzeichnet, dass** die Querrille 0,4 mm breit ist.
- 25 6. Vorrichtung nach Anspruch 1, **dadurch gekennzeichnet, dass** die Wasserdüse (5) weiterhin mindestens eine Bohrung (52) umfasst, die oben am Block (50) definiert ist und mindestens einen Kanal (51) mit dem Äußeren des Blocks (50) verbindet.
- 30 7. Vorrichtung nach Anspruch 1 oder 5, **dadurch gekennzeichnet, dass** sich die Kanäle (51) an einem inneren Punkt des unteren Teils des Blocks (50) treffen, wobei von diesem Punkt eine Öffnung (53) ausgeht, die das Äußere des Blocks (50) erreicht.
- 35 8. Vorrichtung nach Anspruch 1 oder 5, **dadurch gekennzeichnet, dass** sich die Kanäle (51) an einem Punkt des Blocks (50) treffen, der mit dem Äußeren des Blocks (50) verbunden ist und den Kanal (51) an ihrem Schnittpunkt auslaufen lässt.
- 40 9. Vorrichtung nach den Ansprüchen 1 bis 8, **dadurch gekennzeichnet, dass** sich die Kanäle (51) in einer überlappenden Weise schneiden und einen Schnittpunkt erzeugen, der einen Abschnitt mit dem von einem der Kanäle (51) teilt.
- 45 10. Vorrichtung (1) nach Anspruch 1, **dadurch gekennzeichnet, dass** sie eine Überwachungseinheit (6) umfasst, um mindestens den Verteiler zu steuern.
- 50 11. Vorrichtung (1) nach Anspruch 1, **dadurch gekennzeichnet, dass** sie ein Versorgungsmodul (10) umfasst.
- 55 12. Vorrichtung (1) nach Anspruch 1, **dadurch gekennzeichnet, dass** sie Gasversorgungsmittel (11) umfasst.
13. Vorrichtung (1) nach Anspruch 1, **dadurch gekenn-**

zeichnet, dass sie Wasserversorgungsmittel (12) umfasst.

14. Vorrichtung (1) nach Anspruch 1, **dadurch gekennzeichnet, dass** sie mindestens ein erstes Magnetventil (13) umfasst, das an den Gasverteiler angeschlossen ist und zur Steuerung des Gasflusses in den besagten Gasverteiler (7) vorgesehen ist.
15. Vorrichtung (1) nach Anspruch 1, **dadurch gekennzeichnet, dass** sie mindestens ein zweites Magnetventil (14) umfasst, das an den Wasserverteiler angeschlossen ist und zur Steuerung des Wasserflusses in den besagten Wasserverteiler (5) vorgesehen ist.

Revendications

1. Dispositif (1) destiné à la production de revêtements de récipients (2), ledit dispositif (1) comprenant :

un récipient (3) qui comprend au moins un compartiment (4) destiné à loger, au moins partiellement, le récipient (2),

caractérisé en ce que ledit dispositif comprend :

un diffuseur à gaz ayant au moins une buse à gaz (7), la buse à gaz (7) comprenant un corps essentiellement solide (71) avec un orifice borgne central à l'intérieur, corps (71) à l'intérieur duquel sont définis deux filetages (72) des deux côtés d'une section inférieure du corps (71) reliant l'extérieur du corps (71) avec l'orifice borgne central, et

un diffuseur à eau ayant au moins une buse à eau (5) comprenant un bloc (50) à l'intérieur duquel sont définis au moins deux canaux (51), ceux-ci étant respectivement disposés à un angle par rapport à un axe longitudinal central du bloc (50) qui commence par une partie supérieure de ce dernier et qui converge en un point de la partie inférieure du bloc (50).

2. Dispositif selon la revendication 1, **caractérisé en ce que** les filetages (72) sont définis à 45° par rapport à un axe longitudinal central du corps (71).
3. Dispositif selon la revendication 1, **caractérisé en ce que** la partie inférieure du corps (71) comprend en outre une rainure transversale reliant l'extérieur du corps (71) avec un orifice borgne central à l'intérieur du corps (71).
4. Dispositif selon la revendication 1, **caractérisé en ce que** les filetages (72) ont une largeur de l'ordre de 0.35 mm.

5. Dispositif selon la revendication 3, **caractérisé en ce que** la rainure transversale a une largeur de l'ordre de 0,4 mm.

6. Dispositif selon la revendication 1, **caractérisé en ce que** la buse à eau (5) comprend en outre au moins un orifice (52) défini sur la partie supérieure du bloc (50) et reliant au moins un canal (51) avec l'extérieur du bloc (50).

7. Dispositif selon la revendication 1 ou 5, **caractérisé en ce que** les canaux (51) se rejoignent en un point interne de la partie inférieure du bloc (50), point à partir duquel un orifice (53) est formé qui atteint l'extérieur du bloc (50).

8. Dispositif selon la revendication 1 ou 5, **caractérisé en ce que** les canaux (51) se rejoignent en un point du bloc (50) de connexion avec l'extérieur du bloc (50) afin de permettre une sortie de canal (51) à leur intersection.

9. Dispositif selon l'une des revendications 1 à 8, **caractérisé en ce que** les canaux (51) se croisent en se chevauchant afin de créer une intersection ayant une section commune avec celle de l'un des canaux (51).

10. Dispositif (1) selon la revendication 1, **caractérisé en ce qu'il** comprend une unité de suivi (6) pour contrôler au moins le diffuseur.

11. Dispositif (1) selon la revendication 1, **caractérisé en ce qu'il** comprend un module d'alimentation (10).

12. Dispositif (1) selon la revendication 1, **caractérisé en ce qu'il** comprend des moyens d'alimentation en gaz (11).

13. Dispositif (1) selon la revendication 1, **caractérisé en ce qu'il** comprend des moyens d'alimentation en eau (12).

14. Dispositif (1) selon la revendication 1, **caractérisé en ce qu'il** comprend au moins une première électrovanne (13) connectée au diffuseur à gaz et destinée à contrôler le flux de gaz dans ledit diffuseur à gaz (7).

15. Dispositif (1) selon la revendication 1, **caractérisé en ce qu'il** comprend au moins une deuxième électrovanne (14) connectée au diffuseur à eau et destinée à contrôler le flux de l'eau dans ledit diffuseur à eau (5).

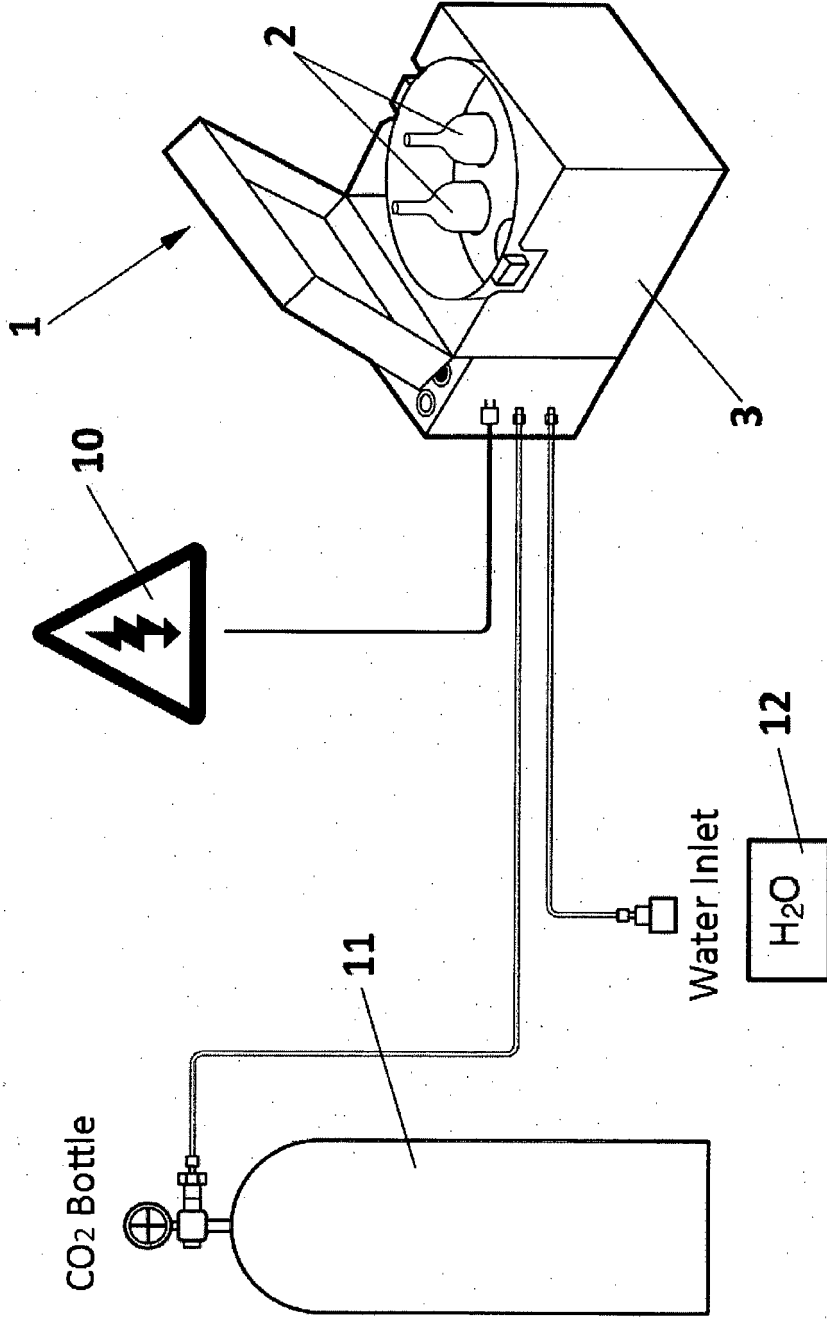

FIG. 1

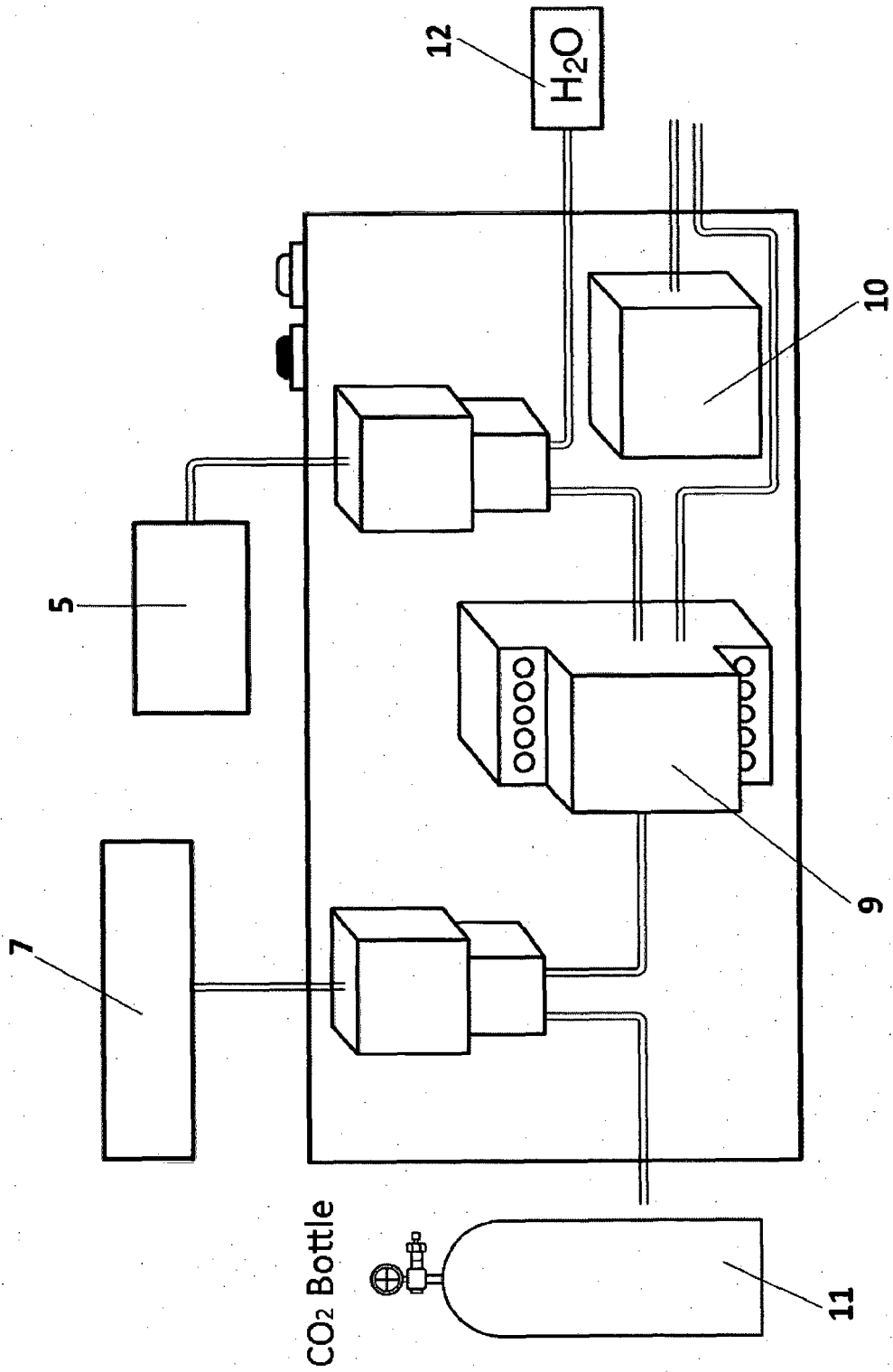

FIG. 2

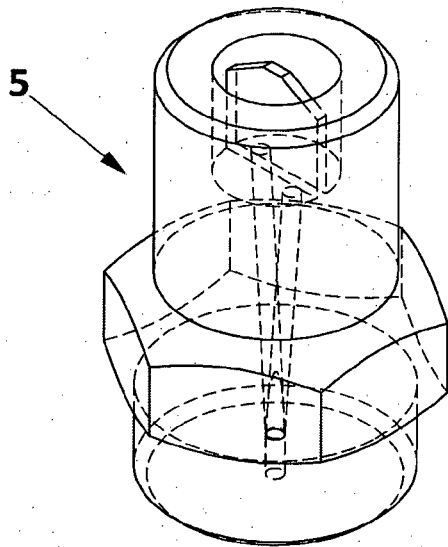

FIG. 3a

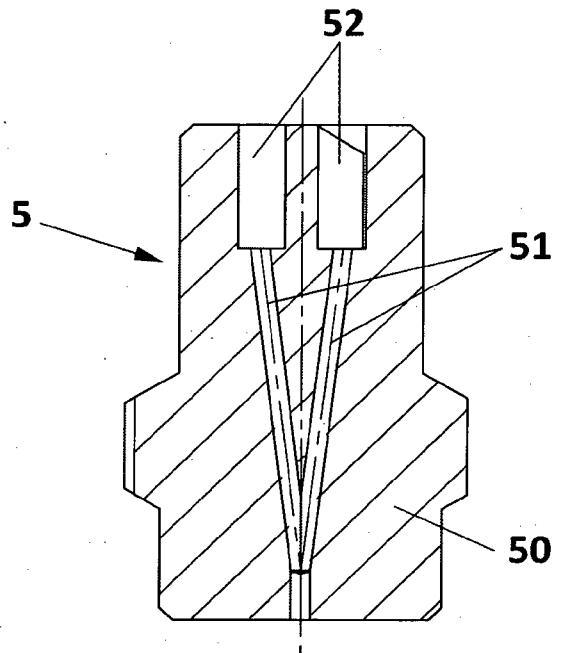

FIG. 3b

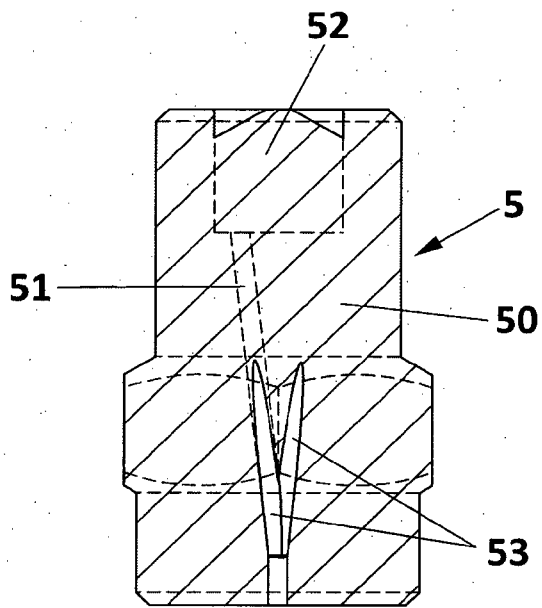

FIG. 3c

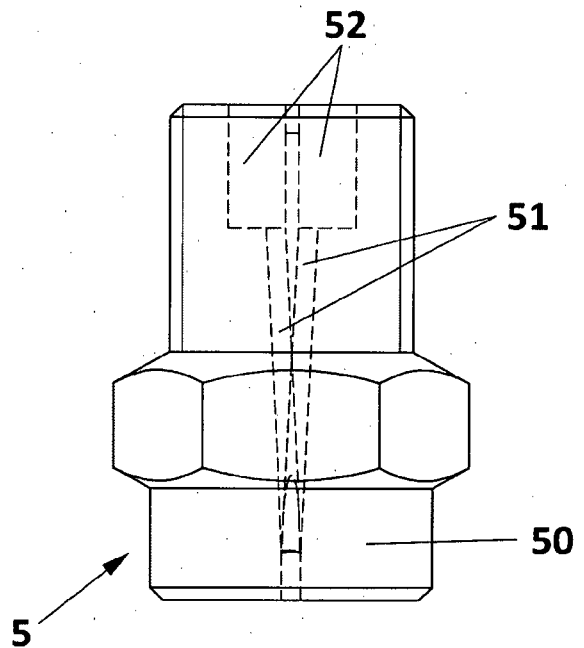

FIG. 3d

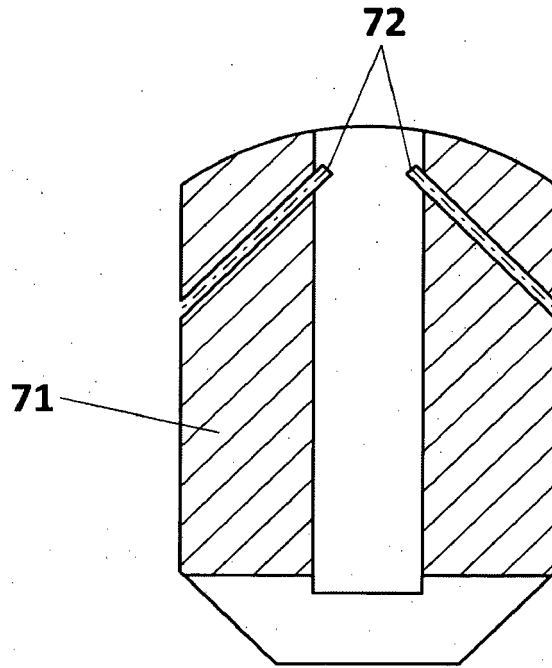

FIG. 4a

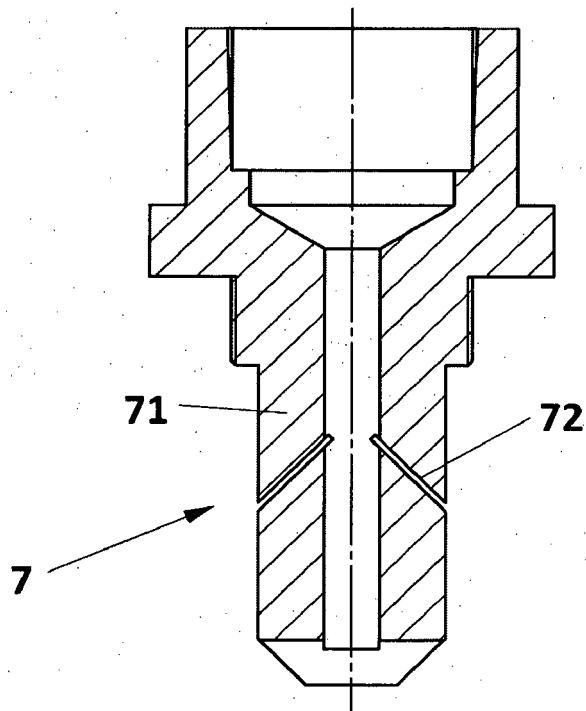

FIG. 4b

REFERENCES CITED IN THE DESCRIPTION

This list of references cited by the applicant is for the reader's convenience only. It does not form part of the European patent document. Even though great care has been taken in compiling the references, errors or omissions cannot be excluded and the EPO disclaims all liability in this regard.

Patent documents cited in the description

- FR 2880104 [0007]
- US 5671604 A [0008]