



(12) **CORRECTED EUROPEAN PATENT APPLICATION**

(15) Correction information:
Corrected version no 1 (W1 A1)
Corrections, see
Bibliography INID code(s) 72

(51) Int Cl.:
B05B 15/12 (2006.01) **B05B 5/03** (2006.01)
B05B 5/035 (2006.01) **B05B 5/043** (2006.01)
B05B 5/08 (2006.01) **B05B 7/14** (2006.01)
B05B 13/04 (2006.01) **B05B 17/06** (2006.01)
B05B 1/08 (2006.01) **B05D 1/06** (2006.01)
B05D 3/12 (2006.01) **C23C 24/04** (2006.01)

(48) Corrigendum issued on:
08.07.2015 Bulletin 2015/28

(43) Date of publication:
13.05.2015 Bulletin 2015/20

(21) Application number: **14192518.0**

(22) Date of filing: **10.11.2014**

(84) Designated Contracting States:
AL AT BE BG CH CY CZ DE DK EE ES FI FR GB
GR HR HU IE IS IT LI LT LU LV MC MK MT NL NO
PL PT RO RS SE SI SK SM TR
 Designated Extension States:
BA ME

- **Xu, Meisheng**
Ottawa, Ontario K1J 6X7 (CA)
- **Panarella, Emilio**
Ottawa, Ontario K1J 6X7 (CA)
- **Yan, Wenzhuo**
Ottawa, Ontario K1J 6X7 (CA)
- **Tieu, Andrew**
Ottawa, Ontario K1J 6X7 (CA)
- **Daniels, Bruce**
Ottawa, Ontario K1J 6X7 (CA)

(30) Priority: **08.11.2013 US 201361901676 P**

(71) Applicant: **VLN Advanced Technologies Inc.**
Ottawa, Ontario K1J 6X7 (CA)

(74) Representative: **Jansen, Cornelis Marinus et al**
V.O.
Johan de Wittlaan 7
2517 JR Den Haag (NL)

(72) Inventors:
 • **Vijay, Mohan**
Ottawa, Ontario K1J 6X7 (CA)

(54) **Integrated fluidjet system for stripping, prepping and coating a part**

(57) A method of stripping, prepping and coating a surface comprises first stripping the existing coating from a surface, using continuous or pulsed fluid jet, followed by prepping the surface by the same fluid jet. The method also provides entraining particles into a fluid stream, if desired to generate a particle-entrained fluid stream that is directed at the surface to be stripped and prepped. The particles act as abrasive particles for prepping the surface to a prescribed surface roughness required for subsequent application of a coating to the surface. The method then entails coating the surface by electrically charging coating particles having the same chemical composition as the particles used to prep the surface. Finally, a charged-particle-entrained fluid stream is directed at high speed at the charged surface to thereby coat the surface. The particles form both mechanical and electronic bonds with the surface.

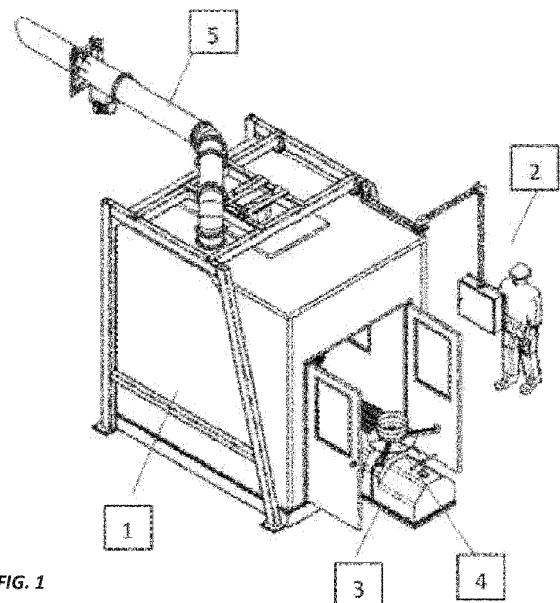

FIG. 1