

(19)



(11)

**EP 2 874 911 B1**

(12)

**EUROPEAN PATENT SPECIFICATION**

(45) Date of publication and mention of the grant of the patent:  
**22.03.2017 Bulletin 2017/12**

(51) Int Cl.:  
**B65D 77/24 (2006.01)**

(21) Application number: **13720427.7**

(86) International application number:  
**PCT/EP2013/059484**

(22) Date of filing: **07.05.2013**

(87) International publication number:  
**WO 2014/012690 (23.01.2014 Gazette 2014/04)**

(54) **A CAN**

DOSE

BOÎTE MÉTALLIQUE

(84) Designated Contracting States:  
**AL AT BE BG CH CY CZ DE DK EE ES FI FR GB GR HR HU IE IS IT LI LT LU LV MC MK MT NL NO PL PT RO RS SE SI SK SM TR**

• **SCHULTE, Axel**  
**DK-7130 Juelsminde (DK)**

(30) Priority: **20.07.2012 DK 201270449**

(74) Representative: **Inspicos P/S**  
**Kogle Allé 2**  
**2970 Hørsholm (DK)**

(43) Date of publication of application:  
**27.05.2015 Bulletin 2015/22**

(56) References cited:  
**EP-A1- 0 648 681 EP-A1- 1 043 244**  
**EP-A1- 1 852 364 EP-A1- 2 070 826**  
**WO-A1-2007/131806 DE-U1- 9 312 692**  
**FR-A- 897 092**

(73) Proprietor: **Glud & Marstrand A/S**  
**8723 Losning (DK)**

(72) Inventors:  
• **ZUBCEVIC, Esad**  
**DK-7100 Vejle (DK)**

**EP 2 874 911 B1**

Note: Within nine months of the publication of the mention of the grant of the European patent in the European Patent Bulletin, any person may give notice to the European Patent Office of opposition to that patent, in accordance with the Implementing Regulations. Notice of opposition shall not be deemed to have been filed until the opposition fee has been paid. (Art. 99(1) European Patent Convention).

## Description

### Introduction

**[0001]** The invention relates to a can forming a space for storage of a product. The can has an opening formed in a top panel for removal of the product from the space, and the opening is sealed by a removable closure, e.g. a peel-off closure. Particularly, the invention relates to a tool and can combination which includes a tool housed in the can, e.g. such that the product can be manipulated by the tool. The invention further relates to a tool which is attachable to a curled end portion of a top panel of an existing can, and to a method of attaching a tool to an existing can design.

### Background of the invention

**[0002]** A can for storing a product, particularly a food product, has been known for a long time. Typically, the known cans comprise a body with a bottom and a side-wall extending towards an open top which is sealed by a cover. To facilitate opening, the cover often includes a pull ring and a score line along which the cover may separate from the body. In this way, users may not need tools for opening the can, and particularly for food storage, cans have become enormously popular e.g. for travellers who may access cheap and healthy food products prefabricated and ready to consume. EP0648681 discloses a can with a spoon attached to an upper end of the can to prevent the spoon from being submersed in the dry contents of the container during transport. Various cans with integrated spoon offer the user manipulation of the food product, e.g. for correct dosage of the product, or for use when being abroad or outside a home environment. Typically, the existing cans include specific holding features provided on the can for the purpose of holding the spoon, and the cans are therefore custom-made for the purpose of integrating a spoon. For this reason, the can and spoon combinations often become expensive. Also, it is typically difficult and time consuming to integrate the existing spoons in the can, and some of the existing spoons tend to release from the can, e.g. when the product is filled into the can, during transportation, or during opening of the can, and the existing spoons may therefore become trapped in the product where they are difficult to retrieve for the user without contamination of hands and/or the product.

### Summary of the invention

**[0003]** It is an object of embodiments of the invention to improve cans and to allow firm attachment of a tool to a top panel of existing cans without modifying the can.

**[0004]** Additionally or alternatively, it is an object of embodiments of the invention to facilitate a more hygienic and safe handling of cans and products contained in cans, e.g. when being home or away from home.

**[0005]** Additionally, it is an object of embodiments of the invention to facilitate a more correct usage of products e.g. with regard to mixing, dosing or measuring of products in a can.

**[0006]** It is a further object to provide a can and tool combination which is simple and cheap and by which the user may easily gain access to the tool.

**[0007]** It is a further object to allow easy and hygienic reuse of the tool.

**[0008]** According to these objects, the invention provides a can with a tool according to claim 1, a tool according to claim 11 and being suitable for attachment to a curled end portion of a top panel of an existing can design, and a method for attaching a tool to a can according to claim 15.

**[0009]** The can according to the invention forms a space for storage of a product and houses inside that space, i.e. below the closure, a tool which is suitable for manipulating the product. The can comprises an opening in a top panel which allows removal of the product from the space and which allows removal of the tool from the can.

**[0010]** Before the user gains access to the product, the opening is sealed by a removable closure, typically a peel off closure. When the peel off closure is removed, the top panel exposes an edge extending about the opening. To avoid sharp edges and thereby potential injuries, an edge portion of the top panel is curled into the space. By "*curled edge*" is herein meant any kind of edge being folded into the space such that the edge around the opening thereby becomes less sharp. Typically, the sharp free edge is curled at least 90-180 degrees around and forms a rounded edge about the opening. The sharp, free, edge thereby becomes located inside the space in the can.

**[0011]** According to the invention, the tool comprises at least one attachment structure configured to be releasably attached to the curled edge portion. Accordingly, the tool-and-can combination according to the invention utilise the folded edge portion as a means for fixing the tool to a lower surface of the top panel. In this way, the folded edge portion may have a double function since it prevents sharp edges and holds the tool. Accordingly, the tool-and-can combination may be produced with a low number of structural can features, which thereby reduces the number of necessary production steps and thereby the manufacturing costs. Particularly, existing cans having a curled edge about an opening in a top panel may be used without modification.

**[0012]** The at least one attachment structure may particularly form a free edge which can be received between a lower surface of the top panel and the free edge of the end portion which is curled into the space. The attachment structure may e.g. comprise at least one recess in a surface of the tool or it may comprise a projection forming a free edge extending upwards from a surface of the tool.

**[0013]** The recess or projection forming a free edge may particularly form a curved free edge, particularly a

free edge having a curvature matching the curvature of the edge about the opening in the can. By "matching" is herein meant that the free edge follows a curvature with a radius equal to or smaller than the radius of the edge about the opening into the can. In that way, the attachment structure may follow the curled edge portion of the top panel over the entire length of the free edge or at least form contact at two locations of the free edge of the projection or recess. This provides a stronger attachment of the tool to the top panel and reduces the risk of displacement of the tool relative to the top panel.

**[0014]** In one embodiment, the tool comprises two attachment structures, one in each opposite end, e.g. a recess in opposite ends of the tool or a free edge extending upwards from a surface in both ends of the tool.

**[0015]** The can could be a two-piece can comprising a body forming a bottom and sidewall extending upwardly from the bottom and formed in one piece with the bottom. At an upper edge of the sidewall, the top panel is attached e.g. by a seaming process of the kind well known for making two-piece cans.

**[0016]** The can could also be a three-piece can comprising a bottom which is attached to a lower edge of the sidewall e.g. by a seaming process and the top panel being attached to an opposite upper surface.

**[0017]** The top panel may be of a generally flat, thin, metal material suitable for seaming processes.

**[0018]** In one embodiment, the edge portion is curled downwards into the space inside the can in such way that the free edge points away from the opening. If the can is circular, it may e.g. point radially outwards, e.g. such that a tangent to the curled edge portion becomes parallel with the inner and outer surfaces of the top panel. Herein, inner surface is the surface facing towards the space inside the can.

**[0019]** The tool may particularly be an oblong tool extending primarily in an axial direction. Examples of such tools include but are not limited to a spoon, a fork, or a knife. In such an oblong tool, the free edge provided by a recess, or similar attachment structure for attachment of the tool to the edge portion, may be provided in both ends of the oblong tool.

**[0020]** Between the two attachment structures provided in opposite ends, the tool may form an intermediate portion which is deformable from a relaxed configuration where the tool follows a curved shape to a tensioned configuration where the tool follow a less curved shape such that a distance along a straight line, herein referred to as "*the straight-line-distance*", between the first and second attachment structures becomes changed by the deformation, i.e. particularly such that the distance increases when the tool is deformed away from the relaxed configuration.

**[0021]** In this way, the tool may easily be attached to the curled end portion of the top panel by pressing the attachment structures of the tool against the curled end portion of the top panel such that the tool deforms and the straight-line-distance increases. This facilitates that

the attachment structures catches the curled end portion, and when the tension is released, the tool flexes back towards the relaxed configuration with a resulting shortening of the straight line distance. This may be utilised to provide a constant pressure between the attachment structures against the curled end portion of the top panel whereby the tool becomes more solidly fixed to the top panel. Accordingly, the deformation of the tool facilitates easy attachment and release of the tool from the folded or curled edge portion of the top panel.

**[0022]** The straight-line-distance may, in the relaxed configuration, correspond to, or be smaller than the distance between the folded or curled edge portion at two diametrically opposite points of the edge around the opening in the top panel, herein referred to as "*the diametrical dimension*". In the tensioned configuration, the attachment dimension may be larger than the diametrical dimension. In that way, the tool may be released from the attachment to the edge portion of the top panel by the increase in the straight-line-distance, and when it returns to the relaxed configuration, the attachment structure may exert the aforementioned pressure provided by the elastically deformability against the edge portion of the top panel.

**[0023]** Particularly, the attachment structures may be provided in an upper surface of the tool whereas the intermediate portion may have a curvature downwards such that the intermediate portion may curve into the space. This is advantageous e.g. in combination with a can which is partly evacuated in the closing procedure. Partly evacuation is sometimes carried out e.g. for increasing the life-time of the product, and during such pressure reduction, the removable closure may deform into the space - i.e. a central portion of the closure may be pressed into the space. The downwards curvature of the tool into the space may prevent the removable closure from getting in contact with and possible pressing the tool down into the product in the space. It may therefore prevent unintentional release of the tool from the top panel.

**[0024]** Since the tool is housed in the space adjacent the closure, it remains protected by the can until the can is opened and the product is consumed. In case of food products, the space may be sterile, and since the tool is in the space, it may be sterilised with the food in one and the same process.

**[0025]** Upon opening of the can, the user will find the tool adjacent the closure and will easily be able remove the tool from the space and use it for manipulating the product, e.g. by providing the aforementioned elastic deformation away from the relaxed configuration.

**[0026]** The can may have any shape and be made of any kind of suitable material, it may e.g. be a traditional circular can made from metal or plastic. The top panel may form a flange extending about the opening, and the flange may have an inner surface towards the space. The tool may particularly be fixed to this inner surface.

**[0027]** The flange may be adhesively joined with the

tool, the flange and tool could be welded, e.g. by use of e-beam welding with compatible materials, or the flange may engage the tool and thereby provide a mechanical fixation. In one example, one of the tool and the can forms a projection which is received in a recess in the other one of the tool and the can.

**[0028]** The tool may be made in one piece from a plastic material, from steel, or from an easily compostable or biodegradable material, e.g. a fibre material, e.g. a paper material.

**[0029]** The tool may form a tool end-portion and a handle portion. The tool end-portion could be joined with a distal end of the handle portion. The tool end-portion is that portion of the tool which is suitable for manipulating the product in the can. The handle portion may form a handle for manipulating the tool end-portion. In one form, the handle portion may be stick shaped or have any similar oblong shape.

**[0030]** The handle portion extends from the distal end towards an opposite free end.

**[0031]** The handle portion may comprise first and second elongated elements being hingely joined at a linkage-end and being movable relative to each other at an opposite free end by rotation at the linkage-end.

**[0032]** The handle may e.g. comprise a base section from which the first and second elements extend. The transition between the base section and the first and second elements may be elastically deformable to thereby form the hinge joint and allow individual rotation of the first and second elements relative to the base section and thus relative to each other. The tool end-portion may be joined to, or it may form an extension of the base section.

**[0033]** Due to the hingely joining of the first and second elements, the free ends of the elements are movable relative to each other between an expanded configuration where the elements extend separately in opposite directions away from the linkage-end, and an assembled configuration where the elements extend in the same direction from the linkage-end and form a handle suitable for manipulating the tool end-portion.

**[0034]** The flange of the can may comprise an edge portion which is folded downwards into the space and defines an edge about the opening. To form mechanical bonding between the tool and the flange, the tool may comprise at least one recess adapted to receive the edge portion tightly to thereby provide a releasable attachment of the tool to the edge portion.

**[0035]** The recess may be formed in each of the free ends of the afore-mentioned elements such that the elements can engage the flange at opposite sides of the flange, e.g. at diametrical opposite sides of a circular can.

**[0036]** In one embodiment, the free ends of the elements terminate at different distance from the linkage-end. When the handle is in the assembled configuration, this will create a step, or thickness change at the position along the length of the handle where one of the elements terminate and the other one continues. The step can be

used for suspending the tool on the edge about the opening of the can.

**[0037]** By suspending the tool on the edge after use, reuse of the tool may be more hygienic, as a person using the tool need not put his hand into the can and especially not into the product when having to manipulate the product again at a later stage.

**[0038]** The tool end-portion may further comprise, or be connected to an overhang for suspending the tool on an edge of the can. In that way, the tool may have a suspension structure in both ends, one being formed by the overhang and one being formed by the different length of the first and second elements.

**[0039]** The overhang and the handle portion may extend in opposite directions away from the tool end-portion.

**[0040]** The tool may be adhesively attached to an inner surface of the can or closure, e.g. by use of an adhesive which is only weakly binding the tool such that it can easily be removed by hand and without destroying the tool or can. The adhesive could e.g. be a hydrocolloid adhesive, e.g. with adhesive properties corresponding to that known from stickers facilitating easy removal without leaving any marks.

**[0041]** Alternatively, or in addition to the adhesive connection, the tool and the can may be joined via an element which forms a score line such that the tool can be broken off from the can along that line.

**[0042]** To form mechanical bonding between the can and the tool, the can and the tool may have concurrent structures for reversible attachment of the tool to the can. This may further facilitate a more hygienic reuse of the tool.

**[0043]** In one embodiment, the concurrent structures comprise a protrusion and an indentation. As an example, a protrusion may be formed at the closure, while an indentation may be formed at the tool, or the reverse.

**[0044]** The indentation may be formed as a through hole e.g. at the handle portion. The protrusion may be of a size being slightly larger than the size of the indentation to provide a press-fit coupling between the can and the tool so that the tool does not slide off the closure when sealing the opening of the can by the closure.

**[0045]** The can according to the invention may have an open bottom portion remote from the top panel, the bottom portion allowing filling of the product into the space and being sealable by a bottom element. Particularly, the can may be prepared with the tool being attached to the top panel. In this state, the can could be delivered to the manufacturer of the product to be contained in the can. The manufacturer may fill the product into the can through the open bottom portion without having to consider the tool which is already attached to the top panel inside the space in the can. When the product is filled into the can, the bottom portion can be attached and the can is ready to be shipped to the consumer.

**[0046]** In a second aspect, the invention provides a tool for attachment to a can, where the can comprises

an opening in a top panel for removal of a product from the space, the opening being sealed by a removable closure, e.g. a peel-off closure. The top panel of the can forms an edge portion forming a free edge inside the space and being folded downwards into the space such that it defines an edge about the opening, characterized in that the tool comprises at least one attachment structure configured to be releasably attached to the edge portion.

**[0047]** The tool may comprise any of the features mentioned already relative to the first aspect of the invention.

**[0048]** Particularly, the tool may comprise a first attachment structure and a second attachment structure arranged on opposite sides of a deformable intermediate portion.

**[0049]** The intermediate portion may particularly be deformable from a relaxed configuration where the tool follows a curved shape to a tensioned configuration where the tool follows a less curved shape such that a distance along a straight line between the first and second attachment structures become changed by the deformation, i. e. particularly such that the straight-line-distance increases when the tool is deformed away from the relaxed configuration.

**[0050]** In this way, the tool may easily be attached to an existing can by pressing the attachment structures of the tool against the curled end portion of the top panel such that the tool deforms axially and the straight-line-distance increases. This facilitates that the attachment structures catches the curled end portion, and when the tension is released, the tool flexes back towards the relaxed configuration with a resulting shortening of the straight line distance. This provides a pressure of the attachment structures against the curled end portion whereby the tool becomes more solidly fixed to the top panel.

**[0051]** To avoid contact between the tool and the removable closure, e.g. if pressure in the can is reduced by partly evacuation, the first and second attachment structures may form free edges at an upper tool surface facing in an upwards direction and the intermediate portion may curve downwards in an opposite downwards direction.

**[0052]** To enable manufacturing of the tool, particularly if the tool is a spoon, and particularly to enable moulding in a simple mould with use of few or no movable core parts, the tool may be spoon-shaped with a bottom portion, and sidewalls extending from the bottom portion towards an upward opening. In this embodiment, the attachment structures could be formed by a free edge extending essentially in the same direction as the sidewall.

**[0053]** In a third aspect, the invention provides a method of attaching a tool to a top panel of a can of the kind having an opening in a top panel for removal of a product from the space, the opening being sealed by a removable closure, and the top panel forming an edge portion forming a free edge inside the space and being folded downwards into the space such that it defines an edge about

the opening, the method comprising inserting the tool through an open bottom portion and affixing the tool to the edge portion.

#### 5 Detailed description

**[0054]** In the following, embodiments of the invention will be described by way of example with reference to the figures in which:

10

Fig. 1 illustrates a can comprising a tool;

Fig. 2 illustrates further details of the attachment of the curled end portion to a recess in the tool;

15

Fig. 3 illustrates a can without the tool;

Fig. 4 illustrates a can with a peel-off closure but with an open bottom portion;

20

Figs. 5-7 illustrate details of one embodiment of a tool in the form of a spoon;

Fig. 8 illustrates release of the tool from the curled end portion by elastic deformation of the tool;

25

Figs. 9-11 illustrate that the tool can rest on an upper surface of the top panel;

30

Figs. 12-14 illustrate a specific embodiment of the tool with a hinged portion; and

Figs. 15-17 illustrate alternative embodiments of the tool.

35

**[0055]** Further scope of applicability of the present invention will become apparent from the following detailed description and specific examples. However, it should be understood that the detailed description and specific examples, while indicating preferred embodiments of the invention, are given by way of illustration only, since various changes and modifications within the scope of the invention will become apparent to those skilled in the art from this detailed description.

45

**[0056]** Fig. 1 illustrates a can 1 forming a space 2 for storage of a product (not shown). The can 1 has an opening 3 formed in a top panel 4 for removal of the product from the space. The opening 3 is sealed by a removable closure 5. Furthermore, the can 1 comprises a tool 6 which is suitable for manipulating the product. In the illustrated embodiment, the tool is a spoon suitable for stirring the product and/or for measuring a dose of the product.

50

**[0057]** In Fig. 1, the tool is of a specific design with a handle portion split into two separate portions. This embodiment of the tool is disclosed in further details in Figs. 12-14, whereas Figs. 2-11 illustrate a simpler tool without the split handle portion.

55

**[0058]** The tool 6 is housed in the space 2 adjacent to the closure 5 and releasably attached to the can 1. Upon opening of the can 1 by removal of the closure 5 from the top panel 4, a user will find the tool 6 directly below the top panel 4. Consequently, the tool 6 can easily be removed from the space 2 and can be used for manipulating the product. The removable closure 5 is of the peel-off kind which is not re-attachable once being peeled off.

**[0059]** The top panel 4 forms a ring-shaped edge portion 8 extending about the opening 3. The top panel 4 has an inner surface towards the space 2 and an opposite outer surface away from the space in the can.

**[0060]** The tool 6 is fixed to edge portion and is therefore adjacent the inner surface. The mechanical fixation of the tool to the edge portion 8 is provided by an attachment structure on the spoon, provided by two free edges, one in each end of the spoon. This is achieved by providing a recess 7 (see Fig. 2) in the tool 6, which recess is formed for engagement with the end portion 8 of the top panel 4.

**[0061]** The end portion is curled and forms an edge about the opening 3 and prevents sharp edges on which the user may become injured. At the same time, the curled end portion forms a projection which fits into the recess 7 of the tool 6. According to the invention the same curled end portion thereby facilitates the detachable attachment of the tool 6 to the inner surface of the top panel 4.

**[0062]** In the illustrated embodiment, the can 1 further comprises a circular lid 16 e.g. of a plastic material. The lid is reusable, i.e. it can be removed and reattached repeatedly, and thereby offers protection of the tool and the product after removal of the removable closure 5.

**[0063]** Fig. 2 illustrates in a cross-section, further details of the mechanical attachment of the tool 6 to the end portion 8 of the top panel 4. This view also illustrates the combination between the lid 16 and the removable peel-off closure 5. The lid forms a space 17 above the top panel. Accordingly, the tool may be located above the top panel and still be within the space 17 and thus be protected by the lid 16. Figs. 2a and 2b illustrate different embodiments of the attachment structure. In both embodiments, the attachment structure forms a free edge which can be received between the lower surface of the top panel and the curled end portion of the top panel. In Fig. 2a, the free edge is a result of a hook-shaped recess and in Fig. 2b, the free edge is an edge of a projection on an upper surface of the tool.

**[0064]** Fig. 3 illustrates the can without the tool 6. In this view, the curled end portion 8 of the top panel 4 is more clearly seen. The edge portion 8 forms a free edge 9 which is potentially very sharp. The free edge 9 is inside the space, i.e. below the peel off closure 5. The free edge points outwards away from the opening and thereby effectively engage the free edge of the hook shaped recess 7 in the tool and holds the tool fixed to the inner surface of the top panel. In the illustrations, the can is circular, and the free edge 9 points radially outwards.

**[0065]** Fig. 4 illustrates a can with the peel off closure 5 attached. The can is a three-piece can comprising a bottom which is attached to a lower edge 10 of the side-wall by a seaming process. In the illustrated stage of manufacture, the top panel and the tool is attached, but the bottom is not yet attached, and the can therefore has an open bottom portion remote from the top panel. The open bottom portion allows filling of the product into the space. When the product is filled into the space, the can is sealed by attachment of the bottom to the lower edge and the can is complete.

**[0066]** Figs. 5-7 illustrate details of one embodiment of the tool 6. In Fig. 5 it is illustrated that the tool has a relaxed configuration in which the tool has a curved shape provided by the bend portion 11. The tool is deformable from the relaxed configuration to a tensioned configuration where the tool follows a less curved shape by a pressure in the direction of the arrow 12.

**[0067]** The deformation of the tool towards the tensioned configuration amends the straight-line-distance between the two recesses 7 by which the tool is attached to the curled end portion of the top panel. The straight-line-distance is illustrated by the arrow 13.

**[0068]** Figs. 8a and 8b illustrate the deformation and release mechanism whereby the tool is attached to, or released from the curled end portion by deformation caused by a force in the direction of the arrow 12, c.f. also the illustrating arrow 14. In Fig. 8a, the free edge of the attachment structure is located under the free edge of the curled end portion of the top panel. When the user presses against the intermediate portion in the direction of the arrow 12, the tool deforms away from the relaxed configuration, and the straight-line-distance increases until the free edge of the attachment structure snaps into the recess between the lower surface of the top panel and the free edge of the curled end portion, c.f. Fig. 8b.

**[0069]** Fig. 9 illustrates that the tool 6 is longer than the diametrical opening size. Due to this larger length of the tool, the tool can be arranged above the top panel 4 protected by the lid 16 in the space 17. This feature is further illustrated in Figs. 10 and 11 and is useful e.g. for the user who, once the can is opened, can reuse the tool without having to re-attach the tool to the curled end portion of the top panel.

**[0070]** Figs. 12-14 illustrate a specific embodiment of the tool.

**[0071]** The tool 6 comprises a tool end-portion 18 and a handle portion 19. The tool end-portion 18 is that portion of the tool 6 which is suitable for manipulating the product in the can 1, whereas the handle portion 19 forms a handle for manipulating the tool end-portion 18.

**[0072]** The tool end-portion 18 is joined with a distal end of the handle portion 19. The handle portion 19 extends from the distal end towards an opposite free end thereby forming a stick shape body (see also Fig. 13).

**[0073]** In this embodiment, the handle portion 19 comprises first and second elongated elements 19a, 19b which are hingely joined at a linkage-end 20 and are mov-

able relative to each other at an opposite free end 21.

**[0074]** The free ends 21 of the elements 19a, 19b are movable relative to each other between an expanded configuration where the elements extend separately in opposite directions away from the linkage-end 20, and an assembled configuration where the elements extend in the same direction from the linkage-end 20 and forms a handle suitable for manipulating the tool end-portion 18. The expanded configuration is illustrated in Fig. 12, whereas the assembled configuration is illustrated in Fig. 13. In order to arrive at the assembled configuration, the free ends 21 of the first and second elements 19a, 19b are moved towards each other as illustrated by the arrows at Fig. 12.

**[0075]** In order to retain the first and second elements 19a, 19b in the assembled configuration, the first and second elements 19a, 19b have concurrent structures, i.e. a protrusion 22 is formed at the first element 19a, while an indentation 23 is formed in the second element 19b. The protrusion 22 is of a size being slightly larger than the size of the indentation 23 to provide a press-fit coupling between the first and second element 19a, 19b so that the handle portion 19 does not open during use by moving the elements 19a, 19b into the expanded configuration.

**[0076]** A recess 7 as described above is formed in each of the free ends 21 of the elements 19a, 19b so that the tool 6 and be attached to the can 1 at both of the first and second elements 19a, 19b defining the handle portion 19.

**[0077]** As illustrated in Fig. 13, the free ends 21 of the elements 19a, 19b terminate at different distance from the linkage-end 20 so that a step 24 is created, when the handle 19 is in the assembled configuration. The step 24 can be used for suspending the tool 6 on the flange or top panel 4 about the opening of the can 1 (see Fig. 14).

**[0078]** Furthermore, the tool end-portion 18 comprises an overhang 25 for suspending the tool 6 on the flange of the top panel 4 of the can 1. In that way, the tool 6 has a suspension structure 24, 25 in both ends, one being formed by the overhang 25 and one being formed by the step 24, i.e. by the different length of the first and second elements 19a, 19b.

**[0079]** The overhang 25 and the handle portion 19 extend in opposite directions away from the tool end-portion 18.

**[0080]** Fig. 15 illustrates a tool in the shape of a spoon 26 having a split handle portion with first and second free ends 27, 28 each having an attachment structure 29, 30. The spoon-head extends downwards away from the upwards attachment structures, and locking structures 31 on the free ends facilitate assembly of the free ends to form one unified handle for the spoon.

**[0081]** Fig. 16 illustrates the tool 26 from Fig. 15 in a can. The arrow 32 illustrates the release and attachment mechanism already described previously. When the tool is pressed in the direction of the arrow 32, the straight-line-distance increases and the attachment structure releases from the curled end portion of the top panel.

**[0082]** Fig. 17 illustrates an alternative embodiment 33 of the tool. In this embodiment, the tool is a spoon suitable for measuring a dose of the product. The spoon has a bottom portion 38 and a sidewall 39 extending upwards from the bottom portion towards the edge 40 extending about the opening into the cavity of the spoon. The spoon faces in a direction such that the spoon cavity is sideways when the attachment structures 34, 35 are attached to a horizontal top panel. In this way, the product will not be collected in the spoon when the can is in a normal upright orientation. The holes 36, 37 provided in the bottom portion 38 are optional. They facilitate filling of the spoon with the product, i.e. the holes release air from the spoon cavity while the product enters the spoon. In the embodiment illustrated in Fig. 17, the cavity of the spoon and the recesses which constitutes the attachment structures 34, 35 are in the same direction, and the holes 36, 37, which can be considered to be optional, all extend in the same direction, and in a moulding process, e.g. a pressure moulding process, the spoon can be manufactured in a simple and cheap tool, typically without use of movable core elements etc.

**[0083]** Numbered additional embodiments:

1. A can forming a space for storage of a product, the can having an opening formed in a top panel for removal of the product from the space, the opening being sealed by a removable closure, characterized in that the can comprises a tool suitable for manipulating the product, the tool being housed in the space adjacent to the closure and releasably attached to at least one of the can and closure.

2. A can according to embodiment 1, where the top panel forms a flange extending about the opening, the flange having an inner surface towards the space and the tool being fixed to the inner surface.

3. A can according to embodiment 2, where the flange engages the tool and provides a mechanical fixation.

4. A can according to any of the preceding embodiments, where the tool comprises a tool end-portion and a handle portion, the tool end-portion being joined with a distal end of the handle portion, and the handle portion extending from the distal end towards an opposite free end, where the handle portion comprises first and second elongated elements being hingely joined at a linkage-end and being movable relative to each other at an opposite free end.

5. A can according to embodiment 4, where the free ends of the elements are movable relative to each other between an expanded configuration where the elements extend separately in opposite directions away from the linkage-end, and an assembled configuration where the elements extend in the same

direction from the linkage-end and forms a handle suitable for manipulating the tool end-portion.

6. A can according to any of embodiments 2-5, where the flange comprises an edge portion which is folded downwards into the space and defines an edge about the opening, and where the tool comprises at least one recess adapted to receive the edge portion tightly to thereby provide a releasable attachment of the tool to the edge portion.

7. A can according to embodiment 5 and 6, where the recess is formed in each of the free ends of the elements.

8. A can according to any of embodiments 4-7, where the free ends of the elements terminate at different distance from the linkage-end.

9. A can according to any of the preceding embodiments, where the tool further comprises an overhang for suspending the tool on an edge of the can.

10. A can according to embodiment 9, where the overhang and the handle portion extend in opposite directions away from the tool end-portion.

11. A can according to any of the preceding embodiments, where the tool is adhesively attached to an inner surface of the can or closure.

12. A can according to any of the preceding embodiments, comprising a score line between the tool and the inner surface of the can facilitating breaking of the tool off from the inner surface of the can or closure.

13. A can according to any of the preceding embodiments, wherein the can and the tool have concurrent structures for reversible attachment of the tool to the can.

14. A can according to embodiment 13, wherein the concurrent structures comprise a protrusion and an indentation.

15. A tool for packaging within a can, the tool comprising a tool end-portion and a handle portion, the tool end-portion being joined with a distal end of the handle portion, and the handle portion extending from the distal end towards an opposite free end, where the handle portion comprises first and second elongated elements being hingely joined at a linkage-end and being movable relative to each other at an opposite free end.

16. A tool according to embodiment 15, where the free ends of the elements are movable relative to

each other between an expanded configuration where the elements extends separately in opposite directions away from the linkage-end, and an assembled configuration where the elements extend in the same direction from the linkage- end and forms a handle suitable for manipulating the tool end-portion.

## Claims

1. A can (1) forming a space (2) for storage of a product and housing in the space a tool (6) which is suitable for manipulating the product, the can comprising an opening (3) in a top panel (4) for removal of the product from the space, the opening being sealed by a removable closure (5), and the top panel forming an edge portion (8) being curled into the space to thereby form a free edge (9) inside the space, the tool comprises a first attachment structure (7) and a second attachment structure (7), and a deformable intermediate portion (11) between the first and second attachment structures, **characterised by** the intermediate portion (11) being deformable from a relaxed configuration where the tool follows a curved shape to a tensioned configuration where the tool follow a less curved shape such that a distance along a straight line between the first and second attachment structures become changed by the deformation, and wherein the tool is configured such that the at least one attachment structure (7) becomes detached from the edge portion upon deformation from the relaxed to the tensioned configuration.
2. A can according to claim 1, where the free edge (9) points outwards away from the opening.
3. A can according to any of the preceding claims, where the at least one attachment structure forms a free edge which can be received between a lower surface of the top panel (4) and the free edge (9).
4. A can according to any of the preceding claims, comprising an attachment structure (7) in opposite ends of the tool.
5. A can according to any of the preceding claims, where the tool comprises a tool-portion (18) suitable for the manipulation of the product and a handle-portion (19) connected to, or formed in one piece with the tool-portion (18), the handle-portion (19) extending from the tool-portion towards a free end remote from the tool-portion, the handle-portion thereby being suitable for a user to grip the tool for manipulation of the tool-portion, and where at least one of the tool portion and the handle portion forms one of the at least one attachment structures.
6. A can according to claim 5, where the handle portion

comprises first and second elongated elements (19a, 19b) being hingely joined at a linkage-end (20) and being movable relative to each other at an opposite free end.

7. A can according to claim 6, where the free ends of the elements are movable relative to each other between an expanded configuration where the elements extends separately in opposite directions away from the linkage-end (20), and an assembled configuration where the elements extend in the same direction from the linkage-end (20) and forms a handle suitable for manipulating the tool end-portion.
8. A can according to claim 7, where the free ends of the elements terminate at different distance from the linkage-end.
9. A can according to any of the preceding claims, comprising an open bottom portion remote from the top panel, the bottom portion allowing filling of the product into the space and being sealable by a bottom element.
10. A tool (6) for a can (1), according to claims 1-9, where the tool comprises a first attachment structure (7) and a second attachment structure (7), and a deformable intermediate portion (11) between the first and second attachment structures, the intermediate portion being deformable from a relaxed configuration where the tool follows a curved shape to a tensioned configuration where the tool follow a less curved shape such that a distance along a straight line between the first and second attachment structures become changed by the deformation.
11. A tool according to claim 10, where the first and second attachment structures form free edges at an upper tool surface facing in an upwards direction and where the intermediate portion (11) curves downwards in an opposite downwards direction.
12. A tool according to any of claims 10-11, having the form of a spoon with a bottom portion, and sidewalls extending from the bottom portion towards an upward opening, the attachment structures being formed by a free edge extending essentially in the same direction as the sidewall.
13. A method of attaching a tool to a top panel of a can according to claim 1-9, the method comprising inserting the tool (6) through an open bottom portion and affixing the tool to the edge portion (8).

#### Patentansprüche

1. Dose (1), die einen Raum (2) zur Lagerung eines

Produktes bildet und in dem Raum ein Werkzeug (6) aufnimmt, das zum Handhaben des Produktes geeignet ist, wobei die Dose eine Öffnung (3) in einem Oberboden (4) für die Entnahme des Produktes aus dem Raum umfasst, wobei die Öffnung durch einen entfernbaren Verschluss (5) verschlossen ist, und der Oberboden einen Kantenabschnitt (8) bildet, der in den Raum gewunden ist, um dadurch eine freie Kante (9) innerhalb des Raumes zu bilden, wobei das Werkzeug eine erste Befestigungsstruktur (7) und eine zweite Befestigungsstruktur (7) und einen verformbaren Zwischenabschnitt (11) zwischen der ersten und zweiten Befestigungsstruktur aufweist, **dadurch gekennzeichnet, dass** der Zwischenabschnitt (11) von einer entspannten Konfiguration, bei der das Werkzeug einer gekrümmten Form folgt, zu einer gespannten Konfiguration, bei der das Werkzeug einer weniger gekrümmten Form folgt, derart verformbar ist, dass eine Distanz entlang einer geraden Linie zwischen der ersten und zweiten Befestigungsstruktur durch die Verformung verändert wird, und wobei das Werkzeug derart ausgebildet ist, dass die mindestens eine Befestigungsstruktur (7) von dem Kantenabschnitt bei der Verformung von der entspannten zur gespannten Konfiguration losgelöst wird.

2. Dose nach Anspruch 1, wobei die freie Kante (9) nach außen von der Öffnung weg weist.
3. Dose nach einem der vorhergehenden Ansprüche, wobei die mindestens eine Befestigungsstruktur eine freie Kante bildet, die zwischen einer niedrigeren Oberfläche des Oberbodens (4) und der freien Kante (9) aufgenommen werden kann.
4. Dose nach einem der vorhergehenden Ansprüche, die eine Befestigungsstruktur (7) an gegenüberliegenden Enden des Werkzeugs umfasst.
5. Dose nach einem der vorhergehenden Ansprüche, wobei das Werkzeug einen Werkzeugabschnitt (18), der für das Handhaben des Produktes geeignet ist, und einen Griffabschnitt (19), der mit dem Werkzeugabschnitt (18) verbunden oder einstückig ausgebildet ist, umfasst, wobei sich der Griffabschnitt (19) von dem Werkzeugabschnitt in Richtung eines dem Werkzeugabschnitt fernen freien Endes erstreckt, wobei der Griffabschnitt dadurch für einen Benutzer geeignet ist, um das Werkzeug für das Handhaben des Werkzeugabschnitts zu ergreifen, und wobei mindestens einer von dem Werkzeugabschnitt und dem Griffabschnitt eine der mindestens einen Befestigungsstruktur bildet.
6. Dose nach Anspruch 5, wobei der Griffabschnitt ein erstes und zweites längliches Element (19a, 19b) umfasst, die an einem Verbindungsende (20) durch

ein Scharnier verbunden und relativ zueinander an einem entgegengesetzten freien Ende beweglich sind.

7. Dose nach Anspruch 6, wobei die freien Enden der Elemente relativ zueinander zwischen einer expandierten Konfiguration, bei der sich die Elemente getrennt in entgegengesetzte Richtungen vom Verbindungsende (20) weg erstrecken, und einer zusammengeführten Konfiguration, bei der sich die Elemente in dieselbe Richtung vom Verbindungsende (20) aus erstrecken, beweglich sind und einen Griff für das Handhaben des Werkzeugendabschnitts bilden.
8. Dose nach Anspruch 7, wobei die freien Enden der Elemente mit unterschiedlicher Distanz zum Verbindungsende enden.
9. Dose nach einem der vorhergehenden Ansprüche, die einen offenen Bodenabschnitt fern vom Oberboden umfasst, wobei der Bodenabschnitt das Abfüllen des Produktes in den Raum erlaubt und durch ein Bodenelement verschließbar ist.
10. Werkzeug (6) für eine Dose (1) nach Ansprüchen 1-9, wobei das Werkzeug eine erste Befestigungsstruktur (7) und eine zweite Befestigungsstruktur (7) und einen verformbaren Zwischenabschnitt (11) zwischen der ersten und zweiten Befestigungsstruktur umfasst, wobei der Zwischenabschnitt von einer entspannten Konfiguration, bei der das Werkzeug einer gekrümmten Form folgt, zu einer gespannten Konfiguration, bei der das Werkzeug einer weniger gekrümmten Form folgt, derart verformbar ist, dass sich eine Distanz entlang einer geraden Linie zwischen der ersten und zweiten Befestigungsstruktur durch die Verformung verändert.
11. Werkzeug nach Anspruch 10, wobei die erste und zweite Befestigungsstruktur freie Kanten an einer oberen Werkzeugoberfläche bilden, die nach oben gerichtet ist, und wobei der Zwischenabschnitt (11) in einer entgegengesetzten Abwärtsrichtung nach unten gekrümmt ist.
12. Werkzeug nach einem der vorhergehenden Ansprüche 10-11, das die Form eines Löffels mit einem Bodenabschnitt und Seitenwänden, die sich vom Bodenabschnitt in Richtung einer nach oben gerichteten Öffnung erstrecken, aufweist, wobei die Befestigungsstrukturen durch eine freie Kante, die sich im Wesentlichen in dieselbe Richtung wie die Seitenwand erstreckt, gebildet sind.
13. Verfahren zum Befestigen eines Werkzeugs an einem Oberboden einer Dose nach Anspruch 1-9, wobei das Verfahren das Einfügen des Werkzeugs (6)

durch einen offenen Bodenabschnitt und das Befestigen des Werkzeugs an dem Kantenabschnitt (8) umfasst.

## Revendications

1. Boite (1) formant un espace (2) pour le stockage d'un produit et le logement dans l'espace d'un outil (6), qui est approprié pour manipuler le produit, la boite comprenant une ouverture (3) dans un panneau supérieur (4) pour retirer le produit de l'espace, l'ouverture étant fermée de façon étanche par un couvercle amovible (5), et le panneau supérieur formant une partie de bordure (8) retroussée dans l'espace de façon à former ainsi un bord libre (9) à l'intérieur de l'espace, l'outil comprend une première structure de fixation (7), et une partie intermédiaire déformable (11) entre les première et seconde structures de fixation, **caractérisé en ce que** la partie intermédiaire (11) est déformable à partir d'une configuration relâchée dans laquelle l'outil suit une forme incurvée vers une configuration tendue dans laquelle l'outil suit une forme moins incurvée de telle sorte qu'une distance le long d'une ligne droite entre les première et seconde structures de fixation est modifiée par la déformation, et dans lequel l'outil est configuré de telle façon que l'au moins une structure de fixation (7) est détachée de la partie de bordure lors de la déformation de la configuration relâchée à la configuration tendue.
2. Boite selon la revendication 1, dans laquelle le bord libre (9) pointe vers l'extérieur en s'éloignant de l'ouverture.
3. Boite selon l'une des revendications précédentes, dans laquelle l'au moins une structure de fixation forme un bord libre qui peut être reçu entre une surface inférieure du panneau supérieur (4) et le bord libre (9).
4. Boite selon l'une des revendications précédentes, comprenant une structure de fixation (7) dans des extrémités opposées de l'outil.
5. Boite selon l'une des revendications précédentes, dans laquelle l'outil comprend une partie d'outil (18) appropriée à la manipulation du produit et une partie de poignée (19) reliée à, ou formée d'une seule pièce avec la partie d'outil (18), la partie de poignée (19) s'étendant à partir de la partie d'outil en direction d'une extrémité libre éloignée de la partie d'outil, la partie de poignée étant ainsi appropriée pour qu'un utilisateur empoigne l'outil pour la manipulation de la partie d'outil, et dans laquelle au moins l'un de la partie d'outil et de la partie de poignée forme une de l'au moins une structure de fixation.

6. Boite selon la revendication 5, dans laquelle la partie de poignée comprend des premier et second éléments allongés (19a, 19b) joints de façon articulée sur une extrémité de liaison (20) et étant mobiles l'un par rapport à l'autre sur une extrémité libre opposée. 5
7. Boite selon la revendication 6, dans laquelle les extrémités libres des éléments sont mobiles l'une par rapport à l'autre entre une configuration étendue où les éléments s'étendent séparément dans des directions opposées à distance de l'extrémité de liaison (20), et une configuration assemblée où les éléments s'étendent dans la même direction à partir de l'extrémité de liaison (20) et forment une poignée adaptée pour manipuler la partie d'extrémité de l'outil. 10  
15
8. Boite selon la revendication 7, dans laquelle les extrémités libres des éléments terminent à une distance différente de l'extrémité de liaison. 20
9. Boite selon l'une des revendications précédentes, comprenant une partie inférieure ouverte distante du panneau supérieur, la partie inférieure permettant le remplissage du produit dans l'espace et pouvant être fermée de façon étanche par un élément inférieur. 25
10. Outil (6) pour une boite (1), selon les revendications 1 - 9, dans lequel l'outil comprend une première structure de fixation (7) et une seconde structure de fixation (7), et une partie intermédiaire déformable (11) entre les première et seconde structures de fixation, la partie intermédiaire étant déformable à partir d'une configuration relâchée où l'outil suit une forme incurvée vers une configuration tendue où l'outil suit une forme moins incurvée de telle sorte qu'une distance le long d'une ligne droite entre les première et seconde structures de fixation est modifiée par la déformation. 30  
35
11. Outil selon la revendication 10, dans lequel les première et seconde structures de fixation forment des bords libres sur une surface d'outil supérieure orientée dans une direction vers le haut et dans laquelle la partie intermédiaire (11) s'incurve vers le bas dans une direction vers le bas opposée. 40  
45
12. Outil selon l'une quelconque des revendications 10-11, ayant la forme d'une cuillère avec une partie inférieure, et des parois latérales s'étendant de la partie intérieure en direction d'une ouverture vers le haut, les structures de fixation étant formées par une extrémité libre s'étendant essentiellement dans la même direction que la paroi latérale. 50
13. Procédé de fixation d'un outil sur un panneau supérieur d'une boite selon les revendications 1 - 9, le procédé comprenant l'insertion de l'outil (6) à travers une partie inférieure ouverte et la fixation de l'outil sur la partie de bordure (8). 55

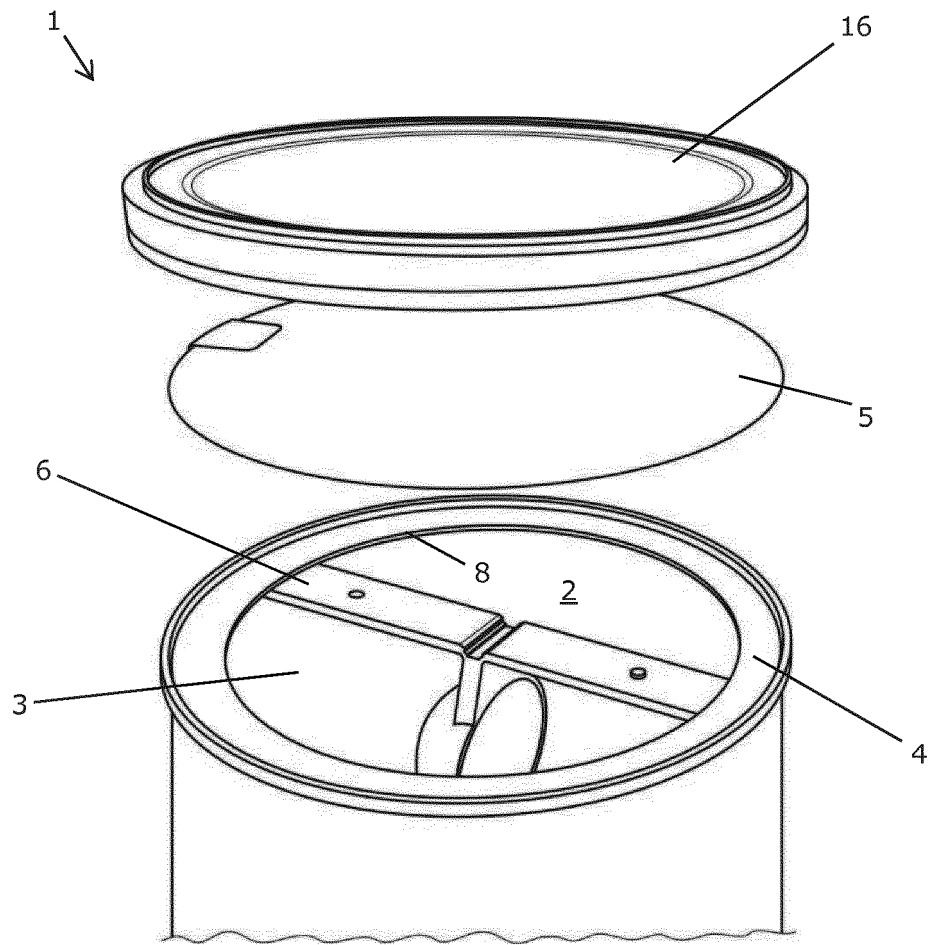

Fig. 1

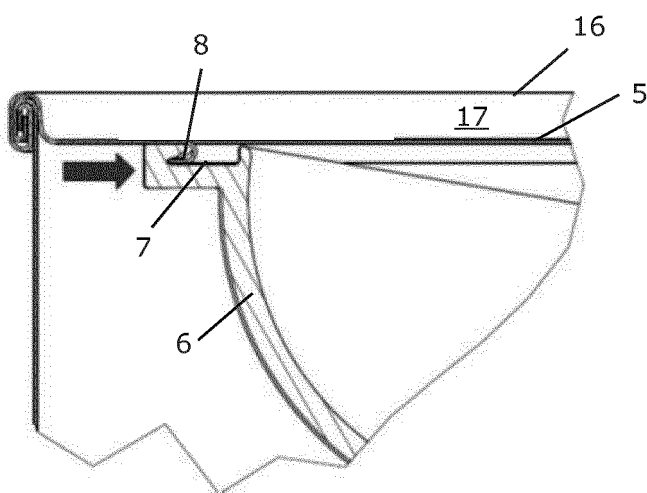

Fig. 2a

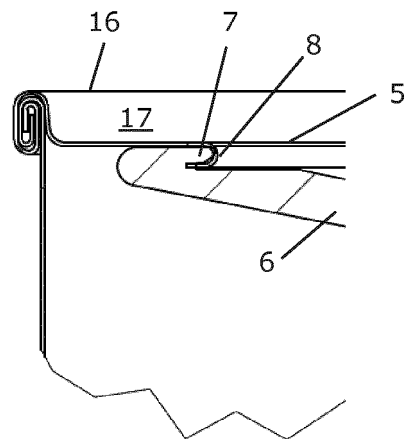

Fig. 2b

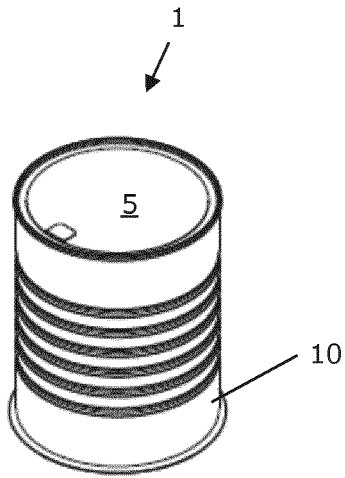

Fig. 4

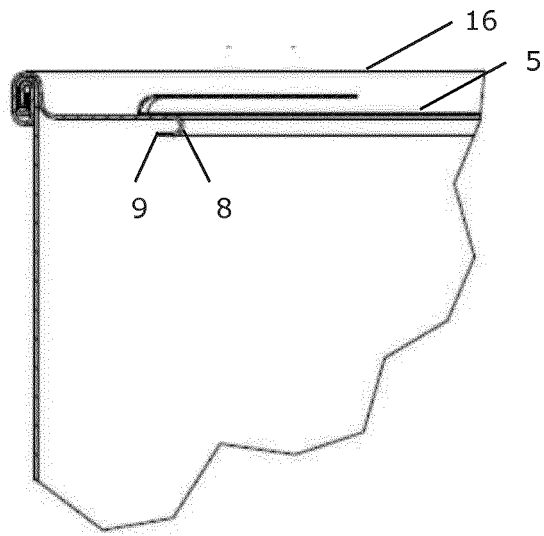

Fig. 3

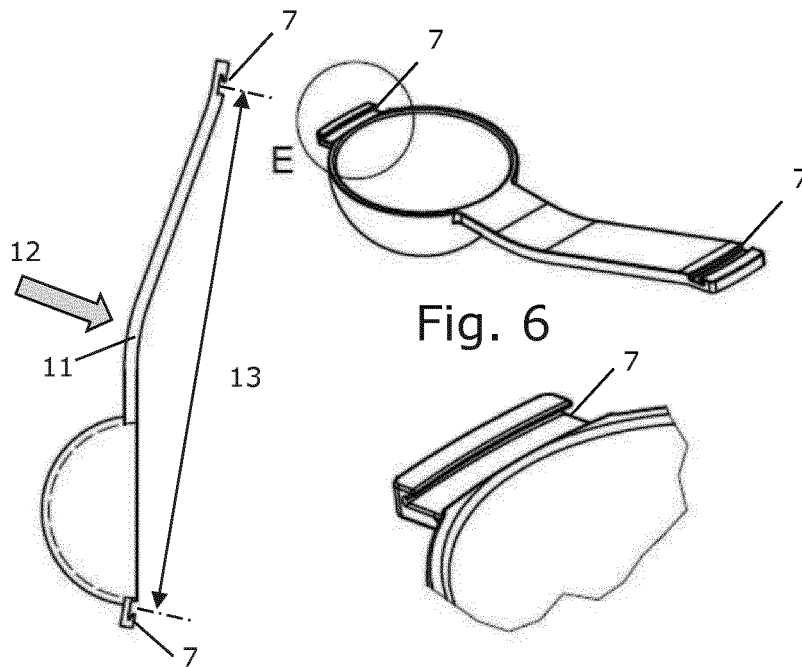

Fig. 5

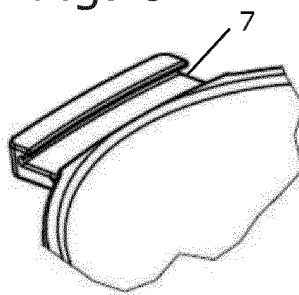

Fig. 6

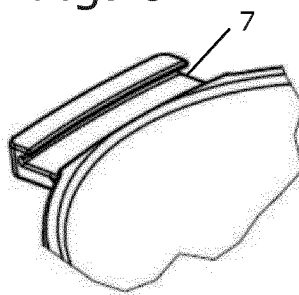

Fig. 7

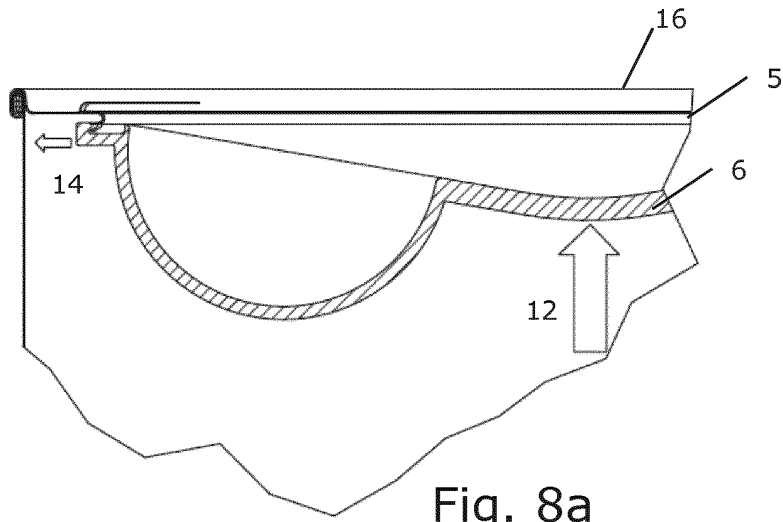

Fig. 8a

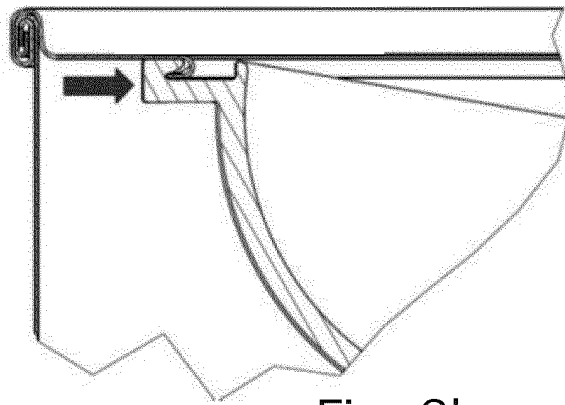

Fig. 8b

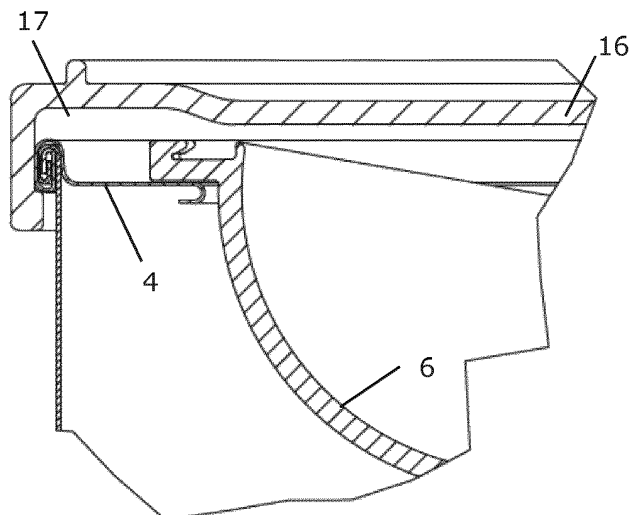

Fig. 9

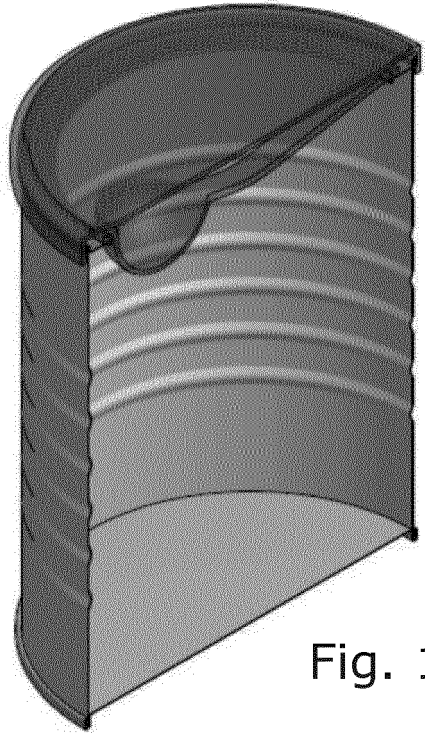

Fig. 10

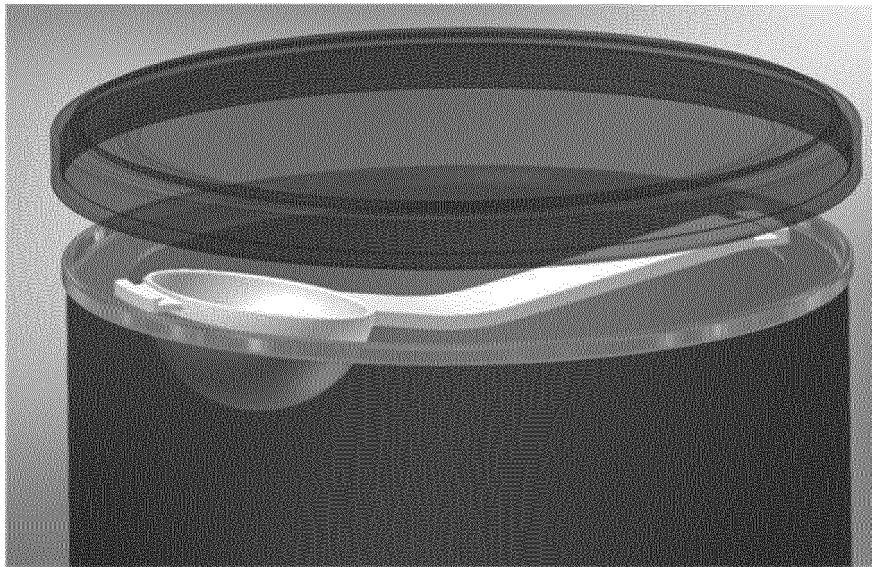

Fig. 11

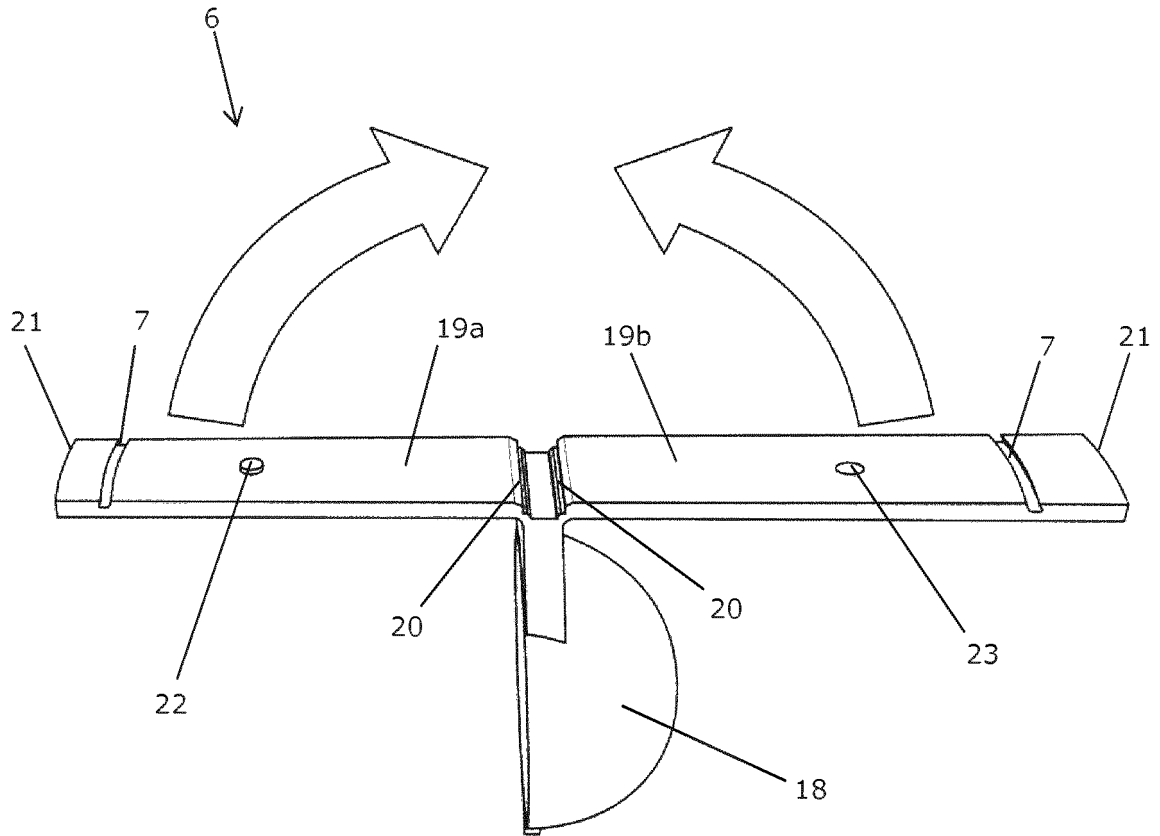

Fig. 12

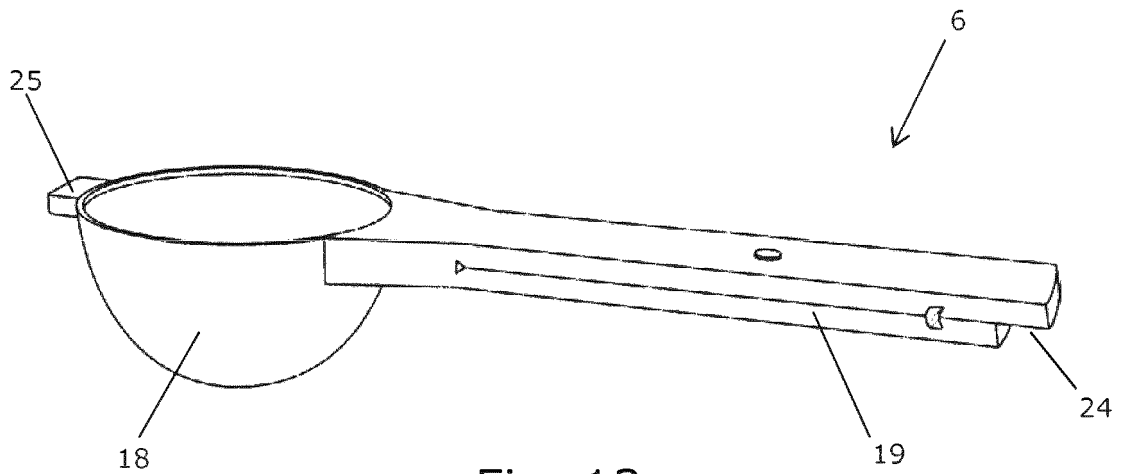

Fig. 13

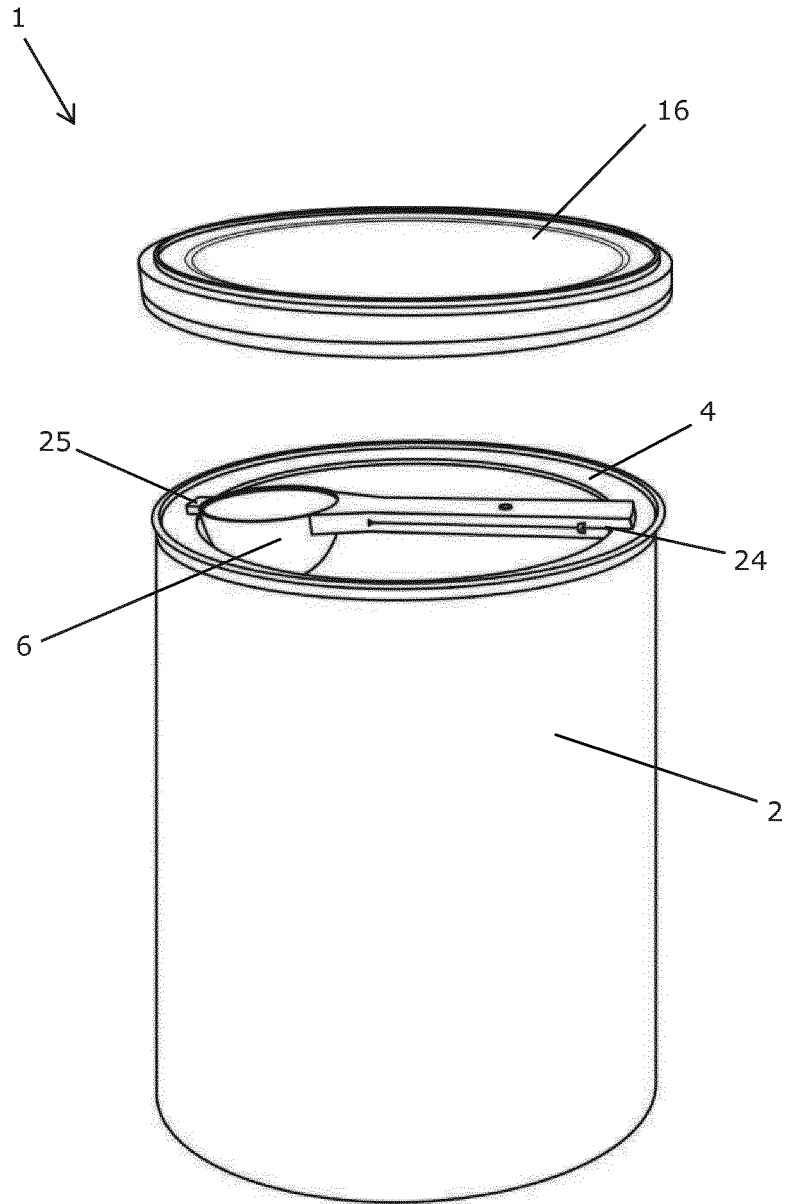

Fig. 14

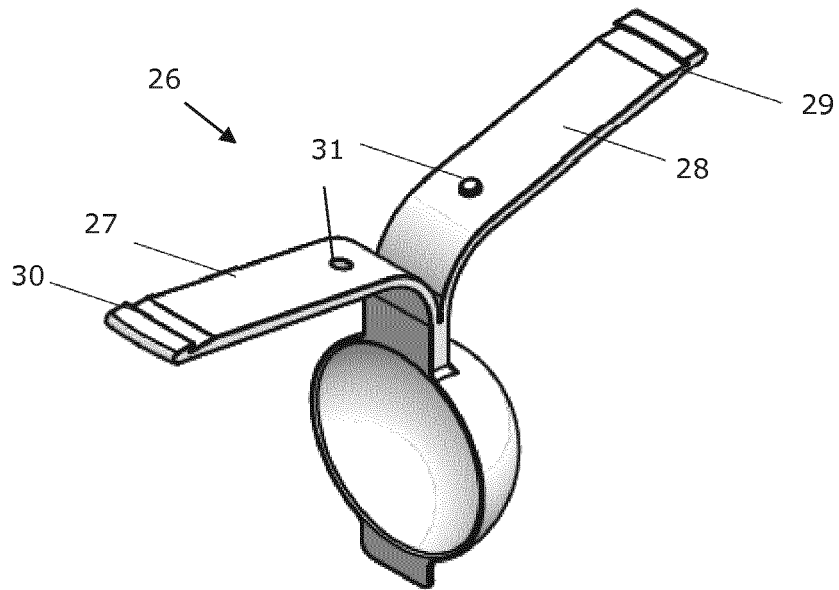

Fig. 15

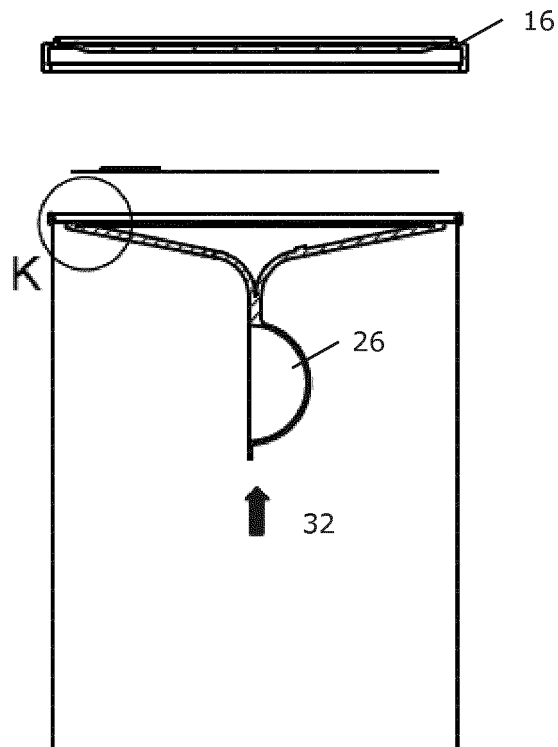

Fig. 16

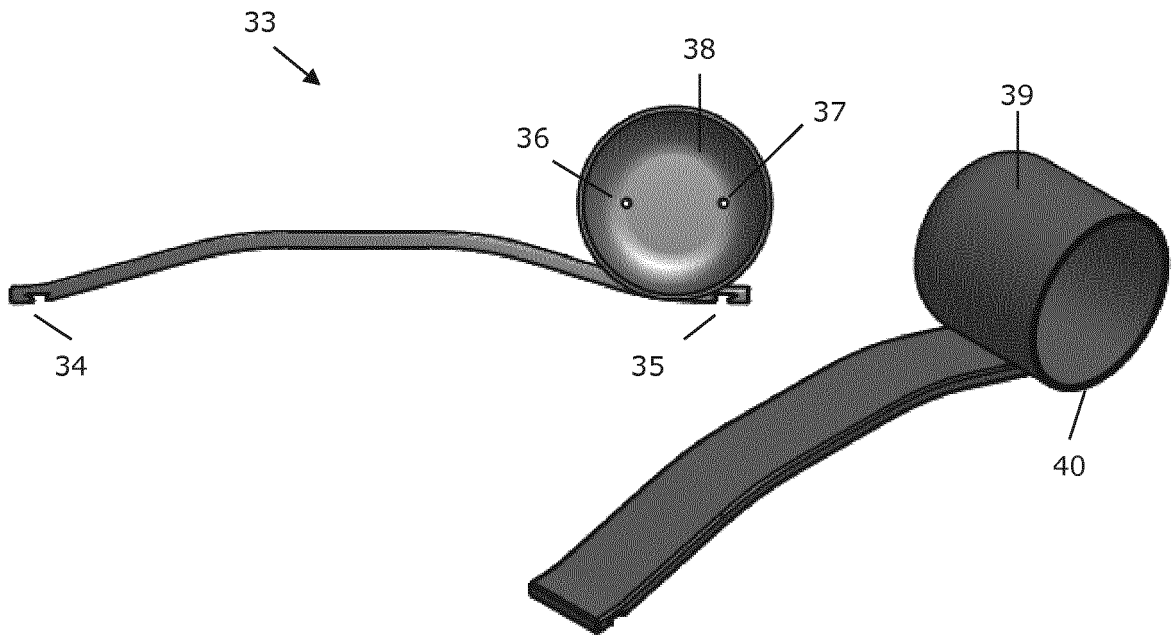

Fig. 17

**REFERENCES CITED IN THE DESCRIPTION**

*This list of references cited by the applicant is for the reader's convenience only. It does not form part of the European patent document. Even though great care has been taken in compiling the references, errors or omissions cannot be excluded and the EPO disclaims all liability in this regard.*

**Patent documents cited in the description**

- EP 0648681 A [0002]