



(11) **EP 2 875 908 B9**

(12) **CORRECTED EUROPEAN PATENT SPECIFICATION**

(15) Correction information:
Corrected version no 1 (W1 B1)
Corrections, see
Drawings

(51) Int Cl.:
B25F 5/00 ^(2006.01) **B25F 5/02** ^(2006.01)

(48) Corrigendum issued on:
05.10.2016 Bulletin 2016/40

(45) Date of publication and mention
of the grant of the patent:
27.07.2016 Bulletin 2016/30

(21) Application number: **14194538.6**

(22) Date of filing: **24.11.2014**

(54) **Power Tool**

Elektrisches Werkzeug

Outil électrique

(84) Designated Contracting States:
AL AT BE BG CH CY CZ DE DK EE ES FI FR GB
GR HR HU IE IS IT LI LT LU LV MC MK MT NL NO
PL PT RO RS SE SI SK SM TR

(30) Priority: **26.11.2013 JP 2013244448**

(43) Date of publication of application:
27.05.2015 Bulletin 2015/22

(73) Proprietor: **Makita Corporation**
Anjo-shi, Aichi 446-8502 (JP)

(72) Inventor: **Machida, Yoshitaka**
Anjo-shi, Aichi 446-8502 (JP)

(74) Representative: **Kramer Barske Schmidtchen**
Patentanwälte PartG mbB
European Patent Attorneys
Landsberger Strasse 300
80687 München (DE)

(56) References cited:
EP-A1- 2 468 455 EP-A2- 2 415 561
WO-A2-2007/068535

EP 2 875 908 B9

Note: Within nine months of the publication of the mention of the grant of the European patent in the European Patent Bulletin, any person may give notice to the European Patent Office of opposition to that patent, in accordance with the Implementing Regulations. Notice of opposition shall not be deemed to have been filed until the opposition fee has been paid. (Art. 99(1) European Patent Convention).

Description

Field of the Invention

[0001] The present invention relates to a power tool which drives a tool bit and performs a predetermined operation.

Background

[0002] WO 2007/068535 discloses a rotary hammer having a drive unit and a transmission unit. A driving torque of the drive unit is transmitted to the transmission unit and thereby an operation is performed. The rotary hammer further comprises a housing unit which houses the drive unit and another housing unit which houses the transmission unit. The housing unit for the drive unit has a main handle integrally jointed to it. Further, the housing unit for the drive unit and the housing unit for the transmission unit are moved relatively to each other and thereby transmission of vibration between the both housing unit is prevented.

Problem to be solved

[0003] In the rotary hammer described above, since the drive unit and the transmission unit are moved relatively to each other, a specially formed bellows-like transmitting member is utilized to allow the relative movement and to transmit the drive torque from the drive unit to the transmission unit. However, to provide the specially formed member which is not widely or generally used member in the rotary hammer may make price of the rotary hammer expensive, further loss of the transmission of the drive torque may be increased.

[0004] Accordingly, an object of the present invention is, in consideration of the above described problem, to provide an improved technique for transmission of torque of the motor and a vibration proof of a main handle in a power tool.

[0005] This object can be solved by providing a power tool according to claim 1.

[0006] According to a preferable aspect, a power tool which drives a tool bit in a longitudinal direction of the tool bit and performs an operation is provided. The power tool comprises a driving mechanism, a motor, a switching member, a main body and a main handle. The driving mechanism is configured to drive the tool bit. The motor has a brush and is configured to drive the driving mechanism. A position of the brush is selectively switched in a first rotational position in which a rotational shaft of the motor rotates in a predetermined first direction and a second rotational position in which the rotational shaft of the motor rotates in a second direction opposite to the first direction. The switching member is manually operated by a user for switching the position of the brush. Further, the switching is movable between a first position which positions the brush in the first rotational position and a

second position which positions the brush in the second rotational position. The main body is configured to hold the driving mechanism, the motor and the switching member. The main handle is biased by a biasing member in the longitudinal direction of the tool bit, which is arranged between the main body and the main handle. Further, the main handle is relatively movable with respect to the main body in a state that the biasing member biases the main handle, and the vibration caused on the main body during the operation is prevented from being transmitted to the main handle. Further, the main handle includes an interference avoidance part which avoids interference between the switching member and the main handle when the switching member is positioned in the first position or the second position and the main handle is moved with respect to the main body. The interference avoidance part is, typically, provided by a recess or a through hole formed on the main handle.

[0007] Generally, a position of the brush with respect to a commutator around a rotational axis of the motor is adjusted and thereby a driving of the motor is optimized. A position of the brush for a forward rotation of the motor and a position of the brush for a reverse rotation of the motor are difference to each other. Therefore, the brush is switched and located at respective positions based on rotation directions of the motor. That is, when the motor is rotated in the forward rotational direction, the brush is configured to be located in a forward rotational position, while when the motor is rotated in the reverse rotational direction, the brush is configured to be located in a reverse rotational position. The forward rotational position corresponds to a first rotational position, and the reverse rotational position corresponds to a second rotational position.

[0008] According to this aspect, as the motor is housed in the main body which holds the tool bit, a specially formed member for transmitting rotation of the motor to the tool bit is not necessary. Further, the main handle is movable with respect to the main body in a state that the main handle is biased by the biasing member. Thus, transmission of vibration from the main body to the main handle is prevented. Accordingly, transmission of rotation of the motor to the tool bit and vibration reduction of the main handle are rationally achieved. Further, the switching member held by the main body is operated by a user, therefore, the switching member is exposed to the outside of the power tool. On the other hand, the main handle and the main body are relatively movable with each other for vibration reduction of the main handle. Thus, the power tool has the interference avoidance part which avoids interference between the switching member and the main handle. Accordingly, the interference avoidance part allows the relative movement of the main handle with respect to the main body.

[0009] According to a further preferable aspect, the first position and the second position are defined as each position in a crossing direction crossing the longitudinal direction of the tool bit. Therefore, the switching member

is configured to move in the crossing direction. Further, the main handle is configured to move in the longitudinal direction of the tool bit with respect to the main body. Further, the main handle has an engagement part which is engageable with the switching member positioned in an intermediate position between the first position and the second position. Further, the main handle is prevented from moving in the longitudinal direction of the tool bit with respect to the main body by an engagement of the switching member and the engagement part.

[0010] According to this aspect, when the motor is driven the main handle is moved with respect to the main body during the operation, interference of the switching member and the main handle is prevented. On the other hand, when the motor is not driven, namely the switching member is positioned in the intermediate position, the main handle is engaged with the switching member. Thus, relative movement of the main handle with respect to the main body is prevented when the power tool is not driven.

[0011] According to a further preferable aspect, the power tool comprises a moving preventing part which prevents the switching member from moving to an intermediate position between the first position and the second position when the switching member is positioned in the first position or the second position and the motor is turned on. The moving preventing part may be configured to directly engage with the switching member and prevent the switching member from moving, or the moving preventing part may be configured to indirectly engage with the switching member via an intervening member and prevent the switching member from moving.

[0012] According to this aspect, the moving preventing part prevents the switching member from moving when the motor is driving. Accordingly, the brush is held in the optimized position based on the rotational direction of the motor when the motor is driving.

[0013] According to a further preferable aspect, the power tool comprises a trigger which is manually operated by a user for driving the motor. Further, the main handle is configured to move between a proximal position which is proximal to the tool bit and a separated position which is separated from the proximal position in the longitudinal direction of the tool bit. Further, the main handle is biased by the biasing member toward the separated position in the longitudinal direction of the tool bit. Further, the moving preventing part is provided with a first preventing portion which is arranged on the trigger and a second preventing portion which is arranged on the main handle. Further, in a state that the motor is driven by manipulation of the trigger, (i) when the main handle is positioned in the proximal position, the second preventing portion engages with the switching member and prevents the switching member from moving to the intermediate position, and (ii) when the main handle is positioned in the separated position, the first preventing portion engages with the switching member and prevents the switching member from moving to the intermediate po-

sition.

[0014] According to this aspect, the main handle is slid against the main body between the proximal position and the separated position during the operation. On the other hand, the switching member is prevented from moving to the intermediate position by the first preventing portion arranged on the trigger or the second preventing portion arranged on the main handle. In other words, the switching member is prevented from moving by not only the main handle but also the trigger. Accordingly, the switching member is prevented from moving to the intermediate position without relation to a position of the main handle when the motor is driving. As a result, the switching member is rationally prevented from moving when the motor is driving, and thereby the brush is stably held in the predetermined position.

[0015] According to a further preferable aspect, the power tool comprises a trigger which is manually operated by a user for driving the motor, and an intervening member which is arranged between the trigger and the switching member. The intervening member is engageable with the trigger and the switching member respectively. Further, the moving preventing part is provided by the intervening member. That is, the intervening member is engageable with both of the trigger and the switching member, respectively. Accordingly, the intervening member engages with the trigger and the switching member and prevents the switching member from moving to the intermediate position without relation to a position of the main handle against the main body in the longitudinal direction of the tool bit. Further, the second preventing portion may be provided on the main handle which is engageable with the switching member. In such a construction, the intervening member engages with the trigger and the switching member and prevents the switching member from moving to the intermediate position, and further the second preventing portion engages with the switching member and preventing the switching member from moving to the intermediate position.

[0016] According to a further preferable aspect, the power tool comprises a trigger switch which is fixed on the main handle and operated by the trigger. Further, the intervening member is supported by the main handle and/or the trigger switch. Further, the intervening member is configured to move integrally with the switching member in a direction crossing the longitudinal direction of the tool bit by engaging with the switching member moving between the first position and the second position. Further, the intervening member is configured to move with respect to the switching member in the longitudinal direction of the tool bit together with a relative movement between the main body and the main handle.

[0017] According to this aspect, the intervening member is supported by the main handle and/or the trigger switch. When the main handle is slid against the main body, the relative position of the trigger and the switching member is changed. On the other hand, the intervening member is supported by the main handle and/or the trig-

ger switch fixed on the main handle such that the intervening member is relatively movable against the switching member, therefore the relative position between the trigger and the intervening member is maintained. Accordingly, the intervening member stably engages with the trigger without relation to a position of the main handle against the main body in the longitudinal direction of the tool bit during an operation. Thus, the switching member is prevented from moving to the intermediate position by the trigger when the motor is driving.

[0018] According to a further preferable aspect, the switching member comprises a brush holding part which holds the brush, the brush holding part being movable around a rotational axis of the motor, and an operated part which is connected to the brush holder, the operated part being manually operated by a user. Further, the operated part is provided such that the operated member protrudes from the brush holding part in a direction perpendicular to the rotational axis of the motor. Further, the interference avoidance part is provided with a through hole which is formed on the main handle. Further, the operated part is exposed to the outside of the power tool by extending through the through hole. Further, the through hole as the interference avoidance part is provided with a first interference avoidance part which extends in the longitudinal direction of the tool bit for avoiding interference between the switching member located in the first position and the main handle and a second interference avoidance part which extends in the longitudinal direction of the tool bit for avoiding interference between the switching member located in the second position and the main handle. Further, the first interference avoidance part and the second interference avoidance part are connected to each other.

[0019] Accordingly, an improved technique for transmission of torque of the motor and a vibration proof of a main handle in a power tool is provided.

[0020] Other objects, features and advantages of the invention will be readily understood after reading the following detailed description together with the accompanying drawings and the claims.

Brief Description of the Drawings:

[0021]

Fig. 1 shows a cross sectional view of a hammer drill according to a first embodiment.

Fig. 2 shows a side cross sectional view of the hammer drill.

Fig. 3 shows a cross sectional view taken along the III-III line in Fig. 2.

Fig. 4 shows an exploded side view of the hammer drill.

Fig. 5 shows a cross sectional view taken along the V-V line in Fig. 2.

Fig. 6 shows a cross sectional view taken along the VI-VI line in Fig. 2.

Fig. 7 shows a cross sectional view taken along the VII-VII line in Fig. 2.

Fig. 8 shows a side view in which a main handle is positioned in a front position.

Fig. 9 shows a cross sectional view of Fig. 8.

Fig. 10 shows a cross sectional view taken along the X-X line in Fig. 9.

Fig. 11 shows an enlarged side view of a handle.

Fig. 12 shows a cross sectional view of Fig. 11.

Fig. 13 shows a cross sectional view taken along the XIII-XIII line in Fig. 12.

Fig. 14 shows an enlarged side view of the handle in which a lever is located corresponding to a forward driving of a motor.

Fig. 15 shows a cross sectional view taken along the XV-XV line in Fig. 14.

Fig. 16 shows an enlarged side view of the handle in which the lever is located corresponding to a reverse driving of the motor.

Fig. 17 shows a cross sectional view taken along the XVII-XVII line in Fig. 16.

Fig. 18 shows an enlarged cross sectional view of a handle according to a second embodiment.

Fig. 19 shows a cross sectional view taken along the XIX-XIX line in Fig. 18.

Fig. 20 shows a cross sectional view of the handle in which a lever is located corresponding to a reverse driving of the motor.

Fig. 21 shows a cross sectional view taken along the XXI-XXI line in Fig. 20.

Fig. 22 shows a cross sectional view in which the handle is located in its front position.

Description of the Preferred Embodiments:

[0022] Each of the additional features and method steps disclosed above and below may be utilized separately or in conjunction with other features and method steps to provide and manufacture improved power tools and method for using such power tools and devices utilized therein. Representative examples of the invention, which examples utilized many of these additional features and method steps in conjunction, will now be described in detail with reference to the drawings. This detailed description is merely intended to teach a person skilled in the art further details for practicing preferred aspects of the present teachings and is not intended to limit the scope of the invention. Only the claims define the scope of the claimed invention. Therefore, combinations of features and steps disclosed within the following detailed description may not be necessary to practice the invention in the broadest sense, and are instead taught merely to particularly describe some representative examples of the invention, which detailed description will now be given with reference to the accompanying drawings.

(First Embodiment)

[0023] An exemplary embodiment is explained with reference to Fig. 1 to Fig. 17. An electrical hammer drill which corresponds to one example of a power tool is utilized to explain the present teachings hereafter. As shown in Fig. 1, the hammer drill 101 is mainly provided with a main body 103, a handle 109 and a hammer bit 119. As shown in Fig. 2 and Fig. 3, a tool holder 137 is arranged at a front region (left side in Fig. 2) of the main body 103 and the hammer bit 119 is detachably attached to the tool holder 137. A grip portion 151 of the handle 109 is arranged at a rear region of the main body 103 which is opposite to the front region in an axial direction of the hammer bit 119.

(Driving Mechanism)

[0024] As shown in Fig. 2 to Fig. 4, the main body 103 is mainly provided with a motor housing 105 which houses a driving motor 111 and a gear housing 107 which houses a motion converting mechanism 113, a hammering element 115 and a rotation transmission mechanism 117. The gear housing 107 comprises a bearing holding portion 107a at its front region, which holds a bearing 137a for supporting the tool holder 137. Further, the gear housing 107 comprises an opening 107b which communicates inside the gear housing 107 with the outside the gear housing 107. The driving motor 111 is one example which corresponds to "a motor".

[0025] Each of the motion converting mechanism 113, the hammering element 115 and the rotation transmission mechanism 117 is one example which corresponds to "a driving mechanism". Further, the main body 103 is one example which corresponds to "a main body".

[0026] The driving motor 111 is arranged such that its rotation axis extends parallel to a longitudinal direction of the hammer bit 119. A cooling fan 112 is mounted on a rotation shaft of the driving motor 111 at a front region of the driving motor 111. That is, the cooling fan 112 is arranged between the driving mechanism and the driving motor 111 with respect to the longitudinal direction of the hammer bit 119. When the driving motor 111 turns, the cooling fan 112 is driven and thereby a cooling air is generated. The cooling fan 112 is formed as a centrifugal fan. The cooling air which is flowed through inside the gear housing 107 is discharged from the opening 107b which is formed on a side surface of the gear housing 107. That is, the opening 107b is provided so as to correspond to the cooling fan 112. A rotational output (torque) of the driving motor 111 is converted to a linear motion in the longitudinal direction of the hammer bit 119 by the motion converting mechanism 113 which is arranged in front of the driving motor 111. Further, the linear motion is transmitted to the hammering element 115 and thereby impact force (hammering force) in the longitudinal direction (lateral direction of the Fig. 1) of the hammer bit 119 is generated by the hammering element 115. Fur-

ther, the rotational output (torque) is transmitted to the rotation transmission mechanism 117 which is arranged in front of the driving motor 111, and then rotation speed of the rotational output is reduced and transmitted to the hammer bit 119. Thus, the hammer bit 119 is rotationally driven. The driving motor 111 is driven (turned on) when a trigger 109a arranged on the handle 109 is manipulated (pulled). For convenience, the hammer bit 119 side of the hammer drill 101 is defined as a front side, and the handle 109 side of the hammer drill 101 is defined as a rear side.

[0027] The motion converting mechanism 113 is mainly provided with an intermediate shaft 125, a swing member 129 and a cylindrical piston 131. The intermediate shaft 125 is arranged parallel to the rotation shaft of the driving motor 111 and driven by the driving motor 111. When the intermediate shaft 125 is rotationally driven, the swing member 129 is swung in the longitudinal direction of the hammer bit 119 via a rotation body 127 mounted on the intermediate shaft 125. When the swing member 129 is swung, the cylindrical piston 131 is linearly driven (reciprocated) in the longitudinal direction.

[0028] The rotation transmission mechanism 117 is mainly provided with a speed reducing gear mechanism which comprises a plurality of gears. The speed reducing gear mechanism is provided with a small diameter gear 133 which is driven integrally with the intermediate shaft 125 and a large diameter gear 135 which meshes with the small diameter gear 133. The rotation transmission mechanism 117 transmits rotation of the driving motor 111 to the tool holder 137. The tool holder 137 is rotatably supported by the bearing 137a which is held on the bearing holding portion 107a. Accordingly, the tool holder 137 is rotationally driven and thereby the hammer bit 119 held by the tool holder 137 is rotationally driven. The bearing holding portion 107a is formed as a metallic cylindrical member made by aluminum like that.

[0029] The hammering element 115 is mainly provided with a striker 143 and an impact bolt 145. The striker 143 is provided as a hammering element which is slidably arranged within the cylindrical piston 131. The impact bolt 145 is provided as an intermediate element which is slidably arranged within the tool holder 137. The striker 143 is driven (slid) by an air spring (air fluctuation) of an air chamber 131a caused by the driving of the cylindrical piston 131 and strikes the impact bolt 145. Accordingly, the hammering force on the hammer bit 119 is caused by the impact bolt 145.

(Brush Holder Unit)

[0030] As shown in Fig. 12 and Fig. 13, the driving motor 111 is provided as a brush motor which includes a brush 170 for providing electric current to a commutator 111a. The brush 170 is held by a brush holder unit 171. In the brush motor, an optimum advanced angle of the motor is determined. Therefore, by controlling the advanced angle of the motor, the brush motor is driven in

an optimized rotation. As to the advanced angle of the motor, an optimum advanced angle of the motor when the motor is driven in a predetermined forward rotation direction and an optimum advanced angle of the motor when the motor is driven in an opposite reverse rotation direction opposite to the forward rotation direction are different to each other. That is, if the advanced angle of the motor for the forward rotation direction is selected and the motor is driven in the reverse rotation direction, it causes a bad effect to a driving of the motor. Therefore, in order not to cause performance differences of the motor driven in the forward rotation direction and in the reverse rotation direction, a position of the brush 170 is set in each optimum advanced angle. In the hammer drill 101, the brush holder unit 171 holds the brush 170 and switches the position of the brush 170.

[0031] As shown in Fig. 12 and Fig. 13, the brush holder unit 171 is mainly provided with a brush holder 172, a spring 173, a rotatable body 174, a lever 175 and a supporting body 176. The brush holder 172 holds the brush 170 to be slidable in a radial direction of the brush holder unit 171 (a radial direction of the commutator 111a). The brush 170 is provided with a positive side brush and a negative side brush, and the respective brushes are supported to be opposite to each other by two brush holders 172 respectively. The spring 173 biases the brush 170 held by the brush holder 172 toward the commutator 111a in the radial direction. The rotatable body 174 is a disk shaped member and the rotatable body 174 is supported by the supporting body 176 which is fixed on the motor housing 105. The rotatable body 174 is configured to rotate integrally with the brush holder 172. As shown in Fig. 12, the supporting body 176 is fixed on the motor housing 105 by screws. As shown in Fig. 13, a recess 174a is formed on the inner surface (commutator side surface) of the rotatable body 174. Further, a projection 176a is formed on the supporting body 176 to be faced the recess 174a. Accordingly, the recess 174a and the projection 176a are engageable with each other. The lever 175 is provided on the rotatable body 174 such that it protrudes from the outer surface of the rotatable body 174 in the radial direction of the rotatable body 174. The lever 175 penetrates an opening 165 formed on the handle rear side part 150 of the handle 109 and thereby the lever 175 is exposed to the outside of the hammer drill 101. Accordingly, a user manipulates the lever 175 from outside the handle 109 and the rotatable body 174 is rotated around a rotational axis of the driving motor 111, and thereby the position of the brush 170 with respect to the commutator 111a is switched (changed). That is, the positive side brush and the negative side brush are rotated integrally and respective positions are switched. When the rotatable body 174 is rotated, the recess 174a and the projection 176a are engaged with each other and thereby further rotation of the rotatable body 174 is prevented. In other words, the movable range of the rotatable body 174 around the commutator 111a is defined by the recess 174a and the projection 176a.

[0032] Specifically, the position of the brush 170 illustrated in Fig. 11 to Fig. 13 is defined as a neutral position of the brush 170 (lever 175). When the lever 175 is manipulated and positioned in the position illustrated in Fig. 14 and Fig. 15, the brush 170 is positioned in a forward rotational position, while, when the lever 175 is manipulated and positioned in the position illustrated in Fig. 16 and Fig. 17, the brush 170 is positioned in a reverse rotational position. Accordingly, the brush 170 is positioned at each optimum position corresponding to the rotation direction (forward or reverse rotational direction) of the driving motor 111. The brush holder unit 171 having the lever 175 is one example which corresponds to "a switching member". Further, the brush holder 172 and the rotatable body 174 is one example which corresponds to "a brush holding part".

[0033] Further, the lever 175 is one example which corresponds to "an operated part".

[0034] The forward and the reverse rotational positions of the brush 170 are examples which correspond to "a first rotational position" and "a second rotational position", respectively.

[0035] In the hammer drill 101 described above, when the driving motor 111 is electrically driven, rotation of the driving motor 111 is converted into the linear motion by the motion converting mechanism 113 and then transmitted to the hammer bit 119 via the hammering element 115. Thus, the hammer bit 119 is linearly driven. Further, rotation of the driving motor 111 is transmitted to the hammer bit 119 via the rotation transmission mechanism 117. Thus, the hammer bit 119 is rotationally driven. As a result, the hammer bit 119 performs a hammer drill operation on a workpiece by the linear and rotational motion of the hammer bit 119.

[0036] As to driving modes of the hammer drill 101, as shown in Fig. 1, the hammer drill 101 comprises a mode select switch 110 for switching the driving modes. When a user manipulates the mode select switch 110, a hammer drill mode and a drill mode as the driving mode of the hammer drill 101 is switched. In the hammer drill mode, the hammer bit 119 is linearly and rotationally driven. In the drill mode, the hammer bit 119 is only rotationally driven.

(Main Handle)

[0037] As shown in Fig. 4, the handle 109 is served as a main handle made of resin, which is held by a user. The handle 109 is mainly provided with a handle rear side part 150 and a handle front side part 155. The handle rear side part 150 is mainly provided with a grip portion 151 which is held by a user and a cylindrical housing portion 152 which is arranged in front of the grip portion 151. The grip portion 151 is connected at a rear end of the housing portion 152 and extended downward from a connecting portion of the grip portion 151 and the housing portion 152. Namely, the grip portion 151 extends in a vertical direction crossing the longitudinal direction of the

hammer bit 119. The distal end of the grip portion 151 is formed as a free end, and a cable for providing an electrical current to the hammer drill 101 is connected to the distal end of the grip portion 151. Further, the housing portion 152 includes an engagement projection 153 which protrudes frontward from the housing portion 152. In this embodiment, two projections 153 are provided.

[0038] The handle front side portion 155 is mainly provided with an auxiliary handle attachable portion 156 to which an auxiliary handle is attached and an extending portion 157 which is extended in the longitudinal direction of the hammer bit 119. The extending portion 157 is arranged at a rear of the auxiliary handle attachable portion 156. The auxiliary handle attachable portion 156 is formed as a ring-like member which surrounds the bearing holding portion 107a of the gear housing 107. Specifically, as shown in Fig. 7, the bearing holding portion 107a is arranged at the front region (hammer bit 119 side region) of the gear housing 107. Further, the bearing holding portion 107a has a plurality of projections 107c which are arranged at the periphery of the bearing holding portion 107a in predetermined interval in the circumference direction. Further, the auxiliary handle attachable portion 156 has a reinforcing ring 156a which engages with the top of the projections 107c. Further, as shown in Fig. 4, the extending portion 157 has an engagement recess 158 which is engagable with the engagement projection 153.

[0039] Further, as shown in Fig. 4, the motor housing 105 has a plurality of sliding guides 106. Each sliding guide 106 is disposed at respective outside position of the motor housing 105 (driving motor 111) in the circumference direction around the longitudinal direction of the hammer bit 119. Further, the sliding guides 106 are disposed at a front side region and a rear side region respectively with respect to the longitudinal direction of the hammer bit 119. Accordingly, the front side sliding guides 106 and the rear side sliding guides 106 are respectively disposed in a plurality positions on the motor housing 105 in the circumference direction of longitudinal direction of the hammer bit 119. The sliding guide 106 is provided with a metallic cover which covers a projection made of resin. The projection is formed on the surface of the motor housing 105. The metallic cover is made of metallic material such as steel, aluminum, magnesium, titanium and so on. Further, a plurality of coil springs 160 are disposed on an outer surface of the motor housing 105.

[0040] As shown in Fig. 5 and Fig. 6, a plurality of recesses 154a which correspond to respective sliding guides 106 and a plurality of pressing portions 154b which correspond to respective coil springs 160 are disposed on an inner surface of the housing portion 152. The recess 154a is formed as a part of the housing portion 152 and therefore made of a resin such as polyamide (nylon). Further, as shown in Fig. 2, a contact portion 154c contactable with the sliding guide 106 is provided on the rear end of the recess 154a. Further, a contact

portion 159a contactable with the front part of the gear housing 107 is provided at the front end of the auxiliary handle attachable portion 156. Further, as shown in Fig. 4, a through hole 159b is formed on the auxiliary handle attachable portion 156.

[0041] As shown in Fig. 1 to Fig. 3, the handle 109 described above is assembled outside the main body 103 such that the handle rear side part 150 is moved from the rear of the main body 103 and the handle front side part 155 from the front of the main body 103, and thereafter the handle rear side part 150 and the handle front side part 155 are connected by engagement of the engagement projection 153 and the engagement recess 158. Thus, the handle 109 is provided such that the housing portion 152 surrounds the motor housing 105 and the extending portion 157 extends along the gear housing 107. When assembled, the extending portion 157 forms a cooling air passage 157A from the opening 107b through the through hole 159b of the auxiliary handle attachable portion 156 between the extending portion 157 and the gear housing 107. The extending portion 157 has a U-shaped cross section orthogonal to an extending direction of the extending portion 157, and therefore the cooling air passage 157A is provided from the opening 107b formed on the side surface of the gear housing 107 to the front region of the gear housing 107 to which the hammer bit 119 is attached. Further, the housing portion 152 is arranged outside the motor housing 105 such that the recess 154a engages with the sliding guide 106 and the pressing portion 154b presses the coil spring 160. Thus, one end of the coil spring 160 contacts with the motor housing 105 and another end of the coil spring 160 contacts with the pressing portion 154b of the housing portion 152 and therefore the coil spring 160 biases the handle rear side part 150 from the motor housing 105. Thus, the handle rear side part 150 is pressed rearward by the coil spring 160 and at this time the contact portion 159a of the handle front side part 155 contacts with the front end part of the gear housing 107, and therefore the rear position of the handle 109 is defined. The coil spring 160 is one example which corresponds to "a biasing member".

[0042] Further, the handle 109 is one example which corresponds to "a main handle".

[0043] A bellow-like member 108 is arranged between the gear housing 107 and the handle rear side portion 150. The bellow-like member 108 is an annular rubber member surrounding the gear housing 107 and extendable and contractable in the longitudinal direction of the hammer bit 119. Accordingly, a relative movement of the handle 109 against the gear housing 107 in the longitudinal direction of the hammer bit 119 is allowed. The bellow-like member 108 is also served as a sealing member which seals a gap between the main body 103 and the handle 109.

(Auxiliary Handle)

[0044] As shown in Fig. 7, the auxiliary handle 190 is configured to attach to the auxiliary handle attachable portion 156 of the handle 109. The auxiliary handle 190 is mainly provided with a holding portion 191 and an attaching portion 195. The holding portion 191 has a grip 192, a flange 193 and a bolt 194. The grip 192 is a substantially cylindrical resin member, which is held by a user. The flange 193 is provided at one end of the grip 192. The bolt 194 is provided such that it extends in a longitudinal direction of the grip 192 and protrudes from the flange 193. The attaching portion 195 has an engagement band 196, a nut 197 and a band holding portion 198. The engagement band 196 is a substantially annular band-like member and both ends of the band are connected to the nut 197. The band holding portion 198 is provided outside the engagement band 196 to support the engagement band 196. A through hole into which the bolt 196 penetrates is formed at a center region of the band holding portion 198.

[0045] In the auxiliary handle 190 described above, the bolt 194 is screwed to the nut 197 and unscrewed from the nut 197 by rotating the holding portion 191 around the longitudinal direction of the holding portion 191 against the band holding portion 198. Accordingly, a distance between the nut 197 and the flange 193 is changed. In a state that the engagement band 196 is arranged so as to surround the auxiliary handle attachable portion 156 of the handle 109, when the holding portion 191 is rotated in one direction around its axis, the engagement band 196 clamps the auxiliary handle attachable portion 156. At this time, the band holding portion 198 is inter-veniently arranged between the engagement band 196 and the flange 193 and thereby the auxiliary handle 190 is mounted to the auxiliary handle attachable portion 156. That is, the auxiliary handle 190 is attached so as to cover (surround) the auxiliary handle attachable portion 156. While, when the holding portion 191 is rotated in another direction around its axis, the engagement band 196 releases the auxiliary handle attachable portion 156. Accordingly, the auxiliary handle 190 is detached from the auxiliary handle attachable portion 156.

(Driving of Hammer Drill)

[0046] In the hammer drill 110 described above, when a user pulls the trigger 109a, the driving motor 111 is turned on. Accordingly, a hammer operation or a hammer drill operation is performed based on the driving mode selected by the mode select switch 110. During the operation by the hammer drill 101, vibration mainly in the longitudinal direction of the hammer bit 119 is occurred on the main body 103. At this time, as the handle 109 is movable with respect to the main body 103 in the longitudinal direction of the hammer bit 119, the handle 109 moves in the longitudinal direction of the hammer bit 119 based on vibration occurred during the operation.

[0047] Specifically, as shown in Fig. 1 to Fig. 3 and Fig. 8 to Fig. 10, the main body 103 and the handle 109 are relatively moved to each other in the longitudinal direction of the hammer bit 119. Fig. 1 to Fig. 3 illustrate the hammer drill 101 in which the handle 109 is positioned in relatively rear position against the main body 103. Further, Fig. 8 to Fig. 10 illustrate the hammer drill 101 in which the handle 109 is positioned in relatively front position against the main body 103.

[0048] As shown in Fig. 1 to Fig. 3, the handle 109 is positioned in a rear position by biasing force of the coil spring 160 (shown in Fig. 4 and Fig. 5). In the rear position, the housing portion 152 is disposed in distance D from the main body 103. The rear position is defined by contact between the contact portion 159a and the front end part of the gear housing 107. Accordingly, the bellow-like member 108 is held in length D between the main body 103 and the housing portion 152. Further, as the auxiliary handle 190 is mounted on the auxiliary handle attachable portion 156 which is a part of the handle 109, the auxiliary handle 190 is also positioned in the rear position together with the handle 109.

[0049] On the other hand, as shown in Fig. 8 to Fig. 10, the handle 109 is positioned in a front position against the biasing force of the coil spring 160 in a state that the biasing force of the coil spring 160 is applied to the handle 109. In the front position, the housing portion 152 is disposed in distance D1 from the main body 103. The distance D1 is shorter than the distance D. The front position is defined by contact between contact portion 154c and the rear end part of the sliding guide 106. Accordingly, the bellow-like member 108 is held in length D1 between the main body 103 and the housing portion 152. At this time, the auxiliary handle 190 is positioned in the front position together with the handle 109.

[0050] The sliding guide 106 and the recess 154a are provided so as to extend parallel to the longitudinal direction of the hammer bit 119. The handle 109 is moved in a state that the sliding guide 106 of the motor housing 105 and the recess 154a of the handle rear side part 150 are engaged with each other, and thereby a moving direction of the handle 109 between the front position and the rear position is defined as being parallel to the longitudinal direction of the hammer bit 119. Further, the reinforcing ring 156a of the auxiliary handle attachable portion 156 is slid on the projection 107c of the gear housing 107 and thereby a moving direction of the auxiliary handle attachable portion 156 is defined as being parallel to the longitudinal direction of the hammer bit 119.

[0051] As described above, in a state that the handle 109 is biased by the coil spring 160, the handle 109 is reciprocally moved between the front position and the rear position by the vibration in the longitudinal direction of the hammer bit 119 during the operation. Thus, kinetic energy of the vibration is consumed by extension and contraction of the coil spring 160, and thereby vibration transmission from the main body 103 to the handle 109 is reduced.

[0052] The cooling air generated by the cooling fan 112 is exhausted from inside to outside the gear housing 107 via the opening 107b. Thereafter, the cooling air is flowed the cooling air passage 157A between the gear housing 107 and the extending portion 157. Further, the cooling air is passed along the outer surface of the metallic bearing holding portion 107a and then exhausted to outside of the hammer drill 101 via the through hole 159b. When the cooling air passes the metallic bearing holding portion 107a, the bearing 137a which is held by the bearing holding portion 107a is cooled. As shown in Fig. 3 and Fig. 10, the opening 107b is not closed (covered) by the handle 109 which is positioned not only in the front position but also in the rear position. Thus, an opening area of the opening 107b is not changed even when the handle 109 is moved. Accordingly, air flow rate of the cooling air is maintained.

[0053] As described above, the handle 109 is slid against the main body 103 during the operation. At this time, as the brush holder unit 171 is supported by the motor housing 105 of the main body 103, the lever 175 of the brush holder unit 171 and the handle 109 are relatively moved. Therefore, the opening 165 is formed on the handle 109 in order to avoid interference between the lever 175 and the handle 109 by the relative movement between the main body 103 and the handle 109, when the lever 175 is positioned corresponding to the forward rotational position or the reverse rotational position of the brush 170. The opening 165 is provided by a through hole formed on the handle 109 which extends in a moving direction of the lever 175 (vertical direction) which is perpendicular to the longitudinal direction of the hammer bit 119, as shown in Fig. 11.

[0054] Specifically, as shown in Fig. 11, the opening 165 is provided with a forward rotational region 165a, a reverse rotational region 165b and an intermediate region 165c. The forward rotational region 165a corresponds to the forward rotational position of the lever 175 which positions the brush 170 in the forward rotational position. Further, the reverse rotational region 165c corresponds to the reverse rotational position of the lever 175 which positions the brush 170 in the reverse rotational position. The forward rotational region 165a and the reverse rotational region 165b extend in the longitudinal direction of the hammer bit 119 such that the length of them are longer than the length of the intermediate region 165c in the longitudinal direction of the hammer bit 119. Therefore, as shown in Fig. 8, when the handle 109 is slid against the main body 103 during the operation, the lever 175 can be positioned within a rear region (right hand region in Fig. 8) of the forward rotational region 165a and thereby interference between the lever 175 and the handle 109 is avoided. Further, similar to the forward rotational region 165a, the lever 175 can be positioned within a rear region of the reverse rotational region 165b and thereby interference between the lever 175 and the handle 109 is also avoided. Each of the forward rotational region 165a and the reverse rotational

region 165b is one example which corresponds to "an interference avoidance part".

[0055] On the other hand, as shown in Fig. 11, when the lever 175 is positioned in the intermediate region 165c, the brush holder 172 prevents the trigger 109a from moving. Specifically, as shown in Fig. 12, the trigger 109a includes an engagement projection 109b which protrudes upward and toward the brush holder unit 171. When the lever 175 is positioned in the intermediate region 165c, a front end part of the brush holder 172 engages with a rear end part of the engagement projection 109b. Thereby, the brush holder 172 prevents the trigger 109a to be manipulated (pulled). That is, movement of the trigger 109a is prevented and thereby driving of the hammer drill 101 is prevented. At this time, the lever 175 engages with the front opening edge or the rear opening edge of the intermediate region 165c of the opening 165, and thereby the handle 109 is prevented from sliding against the main body 103. Each front or rear opening edge of the intermediate region 165c is one example which corresponds to "an engagement part".

[0056] Further, as shown in Fig. 15 and Fig. 17, when the lever 175 is positioned in the forward rotational region 165a or in the reverse rotational region 165b, the engagement projection 109b of the trigger 109a is unengageable with the brush holder 172. Accordingly, manipulation of the trigger 109a is allowed and thereby the hammer drill 101 is drivable. When the trigger 109a is manipulated and positioned in its rear position, a side part of the engagement projection 109b of the trigger 109a engages with a side part of the brush holder 172 and thereby rotation of the brush holder unit 171 is prevented. As a result, when the driving motor 111 is driving, the brush 170 is prevented from moving from the forward rotational position or the reverse rotational position, in other words, the brush 170 is held in the predetermined position (optimum position).

[0057] As described above, when the lever 175 is positioned in the intermediate region 165c which is different from the optimum positions of the brush 170 for driving the driving motor 111, the driving of the hammer drill 101 is prevented. On the other hand, when the lever 175 is positioned within the forward rotational region 165a or the reverse rotational region 165b as optimum position which respectively positions the brush 170 in the forward rotational position or the reverse rotational position for driving the driving motor 111, the driving of the hammer drill 101 is allowed and interference between the lever 175 and the handle 109 is avoided. The position of the lever 175 which positions the brush 170 in the forward rotational position is one example which corresponds to "a first position".

[0058] Further, the position of the lever 175 which positions the brush 170 in the reverse rotational position is one example which corresponds to "a second position".

[0059] According to the first embodiment described above, when the brush 170 is positioned in the neutral position, the brush holder unit 171 engages with the trig-

ger 109a. As a result the driving of the hammer drill 101 is prevented. The brush holder unit 171 has not only a function in which the brush holder unit 171 holds the brush 170 and switches the position of the brush 170 but also another function in which the brush holder unit 171 prevents the hammer drill 101 from driving when the brush 170 is positioned in other than the optimum positions.

[0060] Further, in a state that the brush 170 is positioned in the forward rotational position or in the reverse rotational position, after the trigger 109a is pulled and the hammer drill 101 is driven, the engagement projection 109b of the trigger 109a prevents the brush holder unit 171 from rotating. Accordingly, when the driving motor 111 is driving, the brush 170 is positioned and held in the optimum position.

(Second Embodiment)

[0061] Next, a second embodiment is explained with reference to Fig. 18 to Fig. 22. In the second embodiment, as shown in Fig. 19, a trigger moving preventing member 180 is provided below the brush holder unit 171. Except for the trigger moving preventing member 180, components of the hammer drill 101 are the same as that of the first embodiment, and therefore the same reference numerals are assigned and the explanation of the components is omitted.

[0062] As shown in Fig. 18 and Fig. 19, the trigger moving preventing member 180 is arranged between the trigger 109a and the brush holder unit 171 and supported on the handle rear part 150 of the handle 109. Specifically, the trigger moving preventing member 180 is supported in a relatively rotatable manner around the longitudinal direction of the hammer bit 119 against the handle rear part 150. Accordingly, the trigger moving preventing member 180 is configured to rotate around a rotational axis of the brush holder unit 171. Further, the trigger moving preventing member 180 is supported in a relatively unmovable manner in the longitudinal direction of the hammer bit 119 against the handle rear part 150. Accordingly, the trigger moving preventing member 180 is configured to move integrally with the handle rear part 150. The trigger moving preventing member 180 is one example which corresponds to "an intervening member".

[0063] As shown in Fig. 19, the trigger moving preventing member 180 includes an engagement recess 181 and an engagement projection 182. The engagement recess 181 is provided on the upper surface of the trigger moving preventing member 180 so as to face the brush holder 172 and the engagement recess 181 is engageable with the brush holder 172. Further, the engagement projection 182 is provided below the engagement recess 181 on the lower surface of the trigger moving preventing member 180.

[0064] As shown in Fig. 18 and Fig. 19, when the lever 175 is positioned corresponding to the neutral position of the brush 170, the engagement projection 182 pro-

trudes downward. That is, the engagement projection 182 is arranged such that the front side edge of the engagement projection 182 can be engaged with the rear side edge of the engagement projection 109b of the trigger 109a. As the trigger moving preventing member 180 is unmovable in the longitudinal direction of the hammer bit 119 against the handle rear part 150, the engagement projection 182 engages with the engagement projection 109b and thereby rearward movement of the trigger 109a is prevented. Namely, operation of the trigger 109a is prevented. As a result, driving of the hammer drill 101 is prevented. At this time, the lever 175 engages with the front opening edge or the rear opening edge of the intermediate region 165c of the opening 165, and thereby sliding of the handle 109 with respect to the main body 103 is prevented. Each of the front opening edge and the rear opening edge of the intermediate region 165c is one example which corresponds to "an engagement part".

[0065] As shown in Fig. 20 and Fig. 21, when the lever 175 is manipulated and the brush holder unit 171 is rotated, the trigger moving preventing member 180 is rotated integrally with the brush holder unit 171 while the brush holder 172 engages with the engagement recess 181. When the lever 175 is positioned corresponding to the predetermined position of the brush 170 for driving the driving motor 111, where the position illustrated in Fig. 20 and Fig. 21 corresponds to the reverse rotational position, the engagement projection 182 is deviated from a line passing the trigger 109a and the rotational axis of the driving motor 111. Thereby, the rear side edge of the engagement projection 109b of the trigger 109a is to be unengageable with the front side edge of the engagement projection 182 of the trigger moving preventing member 180, and movement of the trigger is allowed. That is, operation of the trigger 109a is allowed, and when the trigger is operated by a user, the hammer drill 101 is driven.

[0066] When the hammer drill 101 is driven and the predetermined operation is performed, vibration is occurred on the main body 103 during the operation. At this time, the handle 109 slides against the motor housing 105 of the main body 103, in other words, the handle 109 moves between a rear position shown in Fig. 20 and a front position shown in Fig. 22. As similar to the first embodiment, the lever 175 is positioned within the forward rotational region 165a or the reverse rotational region 165b and thereby interference between the lever 175 and the handle 109 is avoided by the forward rotational region 165a or the reverse rotational region of the opening 165.

[0067] When the trigger 109a is manipulated and positioned in the rear position, the driving motor 111 is driven. At this time, the side edge of the engagement projection 109b of the trigger 109a and the side edge of the engagement projection 182 of the trigger moving preventing member 180 are engaged with each other, and thereby the trigger moving preventing member is prevented from moving around the rotational axis of the brush holder unit 171. That is, rotation of the brush holder

unit 171 is prevented. Accordingly, the brush 170 is held in the optimum position when the driving motor 111 is driving.

[0068] In the first embodiment, when the trigger 109a is manipulated, the side edge of the engagement projection 109b of the trigger 109a engages with the side edge of the brush holder 172 and thereby rotation of the brush holder unit 171 is prevented. As the brush holder 172 which is engaged with the trigger 109a is held by the main body 103, the brush holder 172 is moved in longitudinal direction of the hammer bit 119 with respect to the trigger 109a. On the other hand, in the second embodiment, the trigger moving preventing member 180 which is engaged with the trigger 109a is held by the handle 109. Accordingly, when the trigger 109a is manipulated, even if the handle 109 is moved in the longitudinal direction of the hammer bit 119 with respect to the main body 103, the trigger moving preventing member 180 is not moved with respect to the trigger 109a. Thus, the brush 170 is stably held in the optimum position when the driving motor 111 is driving by an engagement between the trigger 109a and the trigger moving preventing member 180.

[0069] According to the second embodiment described above, when the brush 170 is positioned (located) in the neutral position, the trigger moving preventing member 180 prevents the trigger 109 from moving. That is, manipulation of the trigger 109a is prevented and thereby driving of the hammer drill 101 is prevented. Further, in a state that the brush 170 is positioned (located) in the forward rotational position or the reverse rotational position, after the trigger 109a is manipulated and the hammer drill 101 is driven, the engagement projection 109b of the trigger 109a engages with the engagement projection 182 of the trigger moving preventing member 180 and thereby rotation of the brush holder unit 171 is prevented. Accordingly, the brush 170 is held in the optimum position (forward/reverse rotational position) when the driving motor 111 is driving.

[0070] In the second embodiment, the trigger moving preventing member 180 is supported by the handle rear part 150 of the handle 109. However, the trigger moving preventing member 180 may be supported by the trigger switch 109c which is fixed on the handle rear part 150.

[0071] According to the first and the second embodiments described above, the sliding guide 106 guides the handle 109 in the longitudinal direction of the hammer bit 119. Accordingly, in the hammer drill 101 in which vibration mainly in the longitudinal direction of the hammer bit 119 is occurred, since a main direction of the vibration and the moving direction of the handle 109 are in conformity to each other, vibration transmission to the handle 109 is effectively reduced. Further, the driving motor 111 is housed in the motor housing 105 of the main body 103, therefore the lightweight handle 109 is provided. As a result, vibration of the handle 109 is effectively reduced without increasing a consumption amount of kinetic energy of the vibration by the coil spring 160. Fur-

ther, a distance between the driving motor 111 and the motion converting mechanism 113 as well as the rotation transmission mechanism 117 is maintained constant. Accordingly, a specially formed transmitting member which is not widely or generally used member such as a bellows-like transmitting member for transmitting rotation of the driving motor 111 to the motion converting mechanism 113 or the rotation transmission mechanism 117, is not needed.

[0072] Further, according to the first and the second embodiments, a plurality of sliding guide 106 are arranged around the longitudinal direction of the hammer bit 119. Thus, the handle 109 is prevented from moving in a direction other than the longitudinal direction of the hammer bit 119. That is, the handle 109 is moved only in the longitudinal direction of the hammer bit 119. As a result, usability of the hammer drill 101 in which the handle 109 is moved against the main body 103 is improved.

[0073] Further, according to the first and the second embodiments, the handle 106 is guided by the metallic sliding guide 106 and the resin recess 154a. When the handle 109 is moved, a sliding between different materials is occurred. Accordingly, sliding resistance between the sliding guide 106 and the recess 154a is decreased, and thereby the handle 109 is smoothly moved. As a result, vibration transmission to the handle 109 is effectively reduced.

[0074] Further, according to the first and the second embodiments, the handle rear side part 150 and the handle front side part 155 are moved integrally. Therefore, a distance between the grip portion 151 of the handle rear side part 150 and the auxiliary handle 190 which is attached to the auxiliary handle attachable portion 156 of the handle front side part 155 is maintained constant. Accordingly, usability for a user holding the grip portion 151 and the auxiliary handle 190 is improved.

[0075] Further, according to the first and the second embodiments, the extending portion 157 connects the auxiliary handle attachable portion 156 with the housing portion 152 and further forms the cooling air passage 157A. Therefore, another member providing a cooling air passage for cooling the bearing 137a which holds the tool holder 137 is not necessary. Accordingly, number of members of the hammer drill 101 is reduced.

[0076] Further, according to the first and the second embodiments, a plurality of coil springs 160 are arranged around the longitudinal direction of the hammer bit 119. Thus, the handle 109 is stably biased by the springs 160. As a result, vibration transmission to the handle 109 is effectively reduced by the plurality of springs 160.

[0077] Further, according to the first and the second embodiments, coil springs 160 and sliding guides 106 are arranged in the same region with respect to the longitudinal direction of the hammer bit 119. Further, the coil springs 160 and the sliding guides 106 are arranged at respective positions which are different to each other with respect to the circumference direction around the hammer bit 119. Accordingly, outer space of the driving motor

111 is rationally utilized.

[0078] Further, according to the first and the second embodiments, the cooling air flows between the auxiliary handle attachable portion 156 and the gear housing 107. Accordingly, heat generated by a relative sliding of the auxiliary handle attachable portion 156 to the gear housing 107 is effectively discharged to the air.

[0079] Further, according to the first and the second embodiments, when the handle 109 slides against the main body 103, interference between the handle 109 and the lever 175 of the brush holder unit 171 which is held by the main body 103 is avoided.

[0080] In the first and the second embodiments, the opening 165 is formed on the handle 109, however it is not limited to such a construction. For example, the handle rear part 155 may have a recess which extends in the longitudinal direction of the hammer bit 119 at its front end part, and the lever 175 may be located within the recess. In other word, the opening may preferably include hole, recess and so on.

[0081] Further, in the first and the second embodiments, the positive side brush and the negative side brush are rotated integrally with each other by the brush holder 172 and the rotatable body 174. However, the positive side brush and the negative side brush may be separately rotated. Further, at least one of the positive and the negative side brushes may be rotated.

[0082] In the embodiment described above, the coil spring 160 is disposed as a biasing member, however other kind of spring or a rubber like that may be applied to the present teachings. Further, the sliding guide 106 maybe formed by resin and the recess 154a may be formed by metal. Further, the power tool according to the present teachings is not limited to the hammer drill 101. That is, an electric hammer or a reciprocating saw may be applied to the present teachings as a power tool, as long as a power tool generates vibration in a predetermined longitudinal direction.

[0083] Having regard to an aspect of the teachings, following features are provided. Each feature may be utilized independently or in conjunction with other feature (s) or claimed invention(s).

(Feature 1)

[0084] The interference avoidance part is provided by a first through-hole which is formed on the main handle, the through-hole having (1) a first interference avoidance part which avoids interference between the main handle and the switching member is located in the first position, and (2) a second interference avoidance part which avoids interference between the main handle and the switching member located in the second position, and the engagement part is provided by an opening edge of a second through-hole which is formed on the main handle, and the first through-hole and the second through-hole are connected to each other,

and switching member is configured to move through both of the first through-hole and the second through-hole.

5 (Feature 2)

[0085] The second preventing portion is provided by the opening edge of the first through-hole.

10 (Feature 3)

[0086] The length of the first through-hole in the longitudinal direction of the tool bit is longer than the length of the second through-hole.

15 (Feature 4)

[0087] The first through-hole is configured to extend in the longitudinal direction of the tool bit, and the second through-hole is configured to extend in a direction crossing the longitudinal direction of the tool bit.

20 (Feature 5)

[0088] When the switching member is located in the intermediated position between the first position and the second position, the moving preventing part engages with the trigger and prevents the trigger from being operated.

25 (Feature 6)

[0089] The switching member has a substantially circular cross section, and the switching member is configured to rotate around an center axis of the circular cross section and the position of the switching member is switched between the first position and the second position.

30 (Feature 7)

[0090] The intervening member is supported such that the intervening member is rotatable integrally with the switching member against the main handle around the longitudinal direction of the tool bit and the intervening member is unmovable against the main handle in the longitudinal direction of the tool bit.

35 (Feature 8)

[0091] The brush is provided with a positive side brush and a negative side brush, and the switching member is configured to hold the positive and the negative side brushes such that the brushes rotate integrally with each other.

40 (Feature 8)

45 (Feature 8)

(Feature 9)

[0092] The brush is provided with a positive side brush and a negative side brush, and the switching member is configured to switch a position of one brush among the positive side brush and the negative side brush.

(Feature 10)

[0093] The switching member is provided with a brush holding portion which holds the brush, an operated portion which is connected to the brush holding portion and manually operated by a user, and a fixed portion which is fixed on the main body, and the fixed portion is configured to support the brush holding portion in a rotatable manner and the brush holding portion is rotatable with respect to the main body.

(Feature 11)

[0094] A power tool which drives a tool bit in a longitudinal direction of the tool bit and performs an operation, comprising:

a motor which has an output shaft being parallel to the longitudinal direction of the tool bit,
 a driving mechanism which is connected to the output shaft and driven by the motor,
 a main body which houses the motor and the driving mechanism,
 a main handle which is movable with respect to the main body,
 a guide element which guides the main handle such that the main handle moves in the longitudinal direction of the tool bit with respect to the main body, and
 a biasing member which is arranged between the main body and the main handle and biases the main body and the main handle in the longitudinal direction of the tool bit,

wherein the main handle moves against the main body in a state that the main handle is biased by the biasing member, and transmission of vibration generated during the operation from the main body to the main handle is prevented.

[0095] A correspondence relation between each components of the embodiments and features of the teachings is explained as follows. Further, each embodiment is one example to utilize the invention therefore the teachings are not limited to the embodiments.

The hammer drill 101 corresponds to "a power tool".
 The driving motor 111 corresponds to "a motor".
 The brush 170 corresponds to "a brush".
 The brush holder unit 171 corresponds to "a switching member".
 The brush holder 172 corresponds to "a brush hold-

ing part".

The rotatable body 174 corresponds to "a brush holding part".

The lever 175 corresponds to "an operated part".

5 The motion converting mechanism 113 corresponds to "a driving mechanism".

The hammering element 115 corresponds to "a driving mechanism".

10 The rotation transmission mechanism 117 corresponds to "a driving mechanism".

The main body 103 corresponds to "a main body".

The motor housing 105 corresponds to "a main body".

The gear housing 107 corresponds to "a main body".

15 The handle 109 corresponds to "a main handle".

The trigger 109a corresponds to "a trigger".

The trigger switch 109c corresponds to "a trigger switch".

20 The engagement projection 109b corresponds to "a moving preventing part".

The engagement projection 109b corresponds to "a first preventing portion".

The coil spring 160 corresponds to "a biasing member".

25 The forward rotational region 165a corresponds to "an interference avoidance part".

The reverse rotational region 165b corresponds to "an interference avoidance part".

30 The trigger moving preventing member 180 corresponds to "an intervening member".

The trigger moving preventing member 180 corresponds to "a moving preventing part".

35 **[0096]** It is explicitly stated that all features disclosed in the description and/or the claims are intended to be disclosed separately and independently from each other for the purpose of original disclosure as well as for the purpose of restricting the claimed invention independent of the composition of the features in the embodiments and/or the claims. It is explicitly stated that all value ranges or indications of groups of entities disclose every possible intermediate value or intermediate entity for the purpose of original disclosure as well as for the purpose of restricting the claimed invention, in particular as limits of value ranges.

Description of Numerals:

[0097]

50 101 hammer drill
 103 main body
 105 motor housing
 106 sliding guide
 55 107 gear housing
 107a bearing holding portion
 107b opening
 107c projection

108 bellow-like member
 109 handle
 109a trigger
 109b engagement projection
 110 mode select switch
 111 driving motor
 112 cooling fan
 113 motion converting mechanism
 115 hammering element
 117 rotation transmission mechanism
 119 hammer bit
 125 intermediate shaft
 127 rotatable body
 129 swing member
 131 cylindrical piston
 131a air chamber
 133 small diameter gear
 135 large diameter gear
 137 tool holder
 137a bearing
 143 striker
 145 impact bolt
 150 handle rear side part
 151 grip portion
 152 housing portion
 153 engagement projection
 154a recess
 154b pressing portion
 154c contact portion
 155 handle front side part
 156 auxiliary handle attachable portion
 156a reinforcing ring
 157 extending portion
 157A cooling air passage
 158 engagement recess
 159a contact portion
 159b through hole
 160 coil spring
 165 opening
 165a forward rotational region
 165b reverse rotational region
 165c intermediate region
 170 brush
 171 brush holder unit
 172 brush holder
 173 spring
 174 rotatable body
 175 lever
 176 supporting body
 180 trigger moving preventing member
 181 engagement recess
 182 engagement projection
 190 auxiliary handle
 191 holding portion
 192 grip
 193 flange
 194 bolt
 195 attaching portion

5

10

15

20

25

30

35

40

45

50

55

196 engagement band
 197 nut
 198 band holding portion

Claims

1. A power tool which is adapted to drive a tool bit (119) in a longitudinal direction of the tool bit (119) and perform an operation, comprising:

a driving mechanism (113, 115, 117) which drives the tool bit (119),

a motor (111) which has a brush (170) and configured to drive the driving mechanism (113, 115, 117), a position of the brush (170) being selectively switched in a first rotational position in which a rotational shaft of the motor (111) rotates in a predetermined first direction and a second rotational position in which the rotational shaft of the motor (111) rotates in a second direction opposite to the first direction, a switching member (171) which is manually operated by a user for switching the position of the brush (170) and is movable between a first position which positions the brush (170) in the first rotational position and a second position which positions the brush (170) in the second rotational position,

a main body (103) which holds the driving mechanism (113, 115, 117), the motor (111) and the switching member (171), and

a main handle (109) which is biased by a biasing member (160) in the longitudinal direction of the tool bit, which is arranged between the main body (103) and the main handle (109), and the main handle (109) is relatively movable with respect to the main body (103) in a state that the biasing member (160) biases the main handle (109), and the vibration caused on the main body (103) during the operation is prevented from being transmitted to the main handle (109),

wherein

the switching member is manipulateable by a user from outside the main handle (9), and the main handle (109) includes an interference avoidance part (165a, 165b) which avoids interference between the switching member (171) and the main handle (109) when the switching member (171) is positioned in the first position or the second position and the main handle (109) is moved with respect to the main body (103).

2. The power tool according to claim 1, wherein the first position and the second position are defined as each position in a crossing direction crossing the longitu-

- dinal direction of the tool bit (119) and the switching member (171) is configured to move in the crossing direction,
and wherein the main handle (109) is configured to move in the longitudinal direction of the tool bit (119) with respect to the main body (103) and the main handle (109) has an engagement part (165c) which is engageable with the switching member (171) positioned in an intermediate position between the first position and the second position,
and wherein the main handle (109) is prevented from moving in the longitudinal direction of the tool bit (119) with respect to the main body (103) by an engagement of the switching member (171) and the engagement part (165c).
3. The power tool according to claim 1 or 2, further comprising a moving preventing part (109b; 180) which prevents the switching member (171) from moving to an intermediate position between the first position and the second position when the switching member (171) is positioned in the first position or the second position and the motor (111) is turned on.
 4. The power tool according to claim 3, further comprising a trigger (109a) which is manually operated by a user for driving the motor (111), wherein the main handle (109) is configured to move between a proximal position which is proximal to the tool bit (119) and a separated position which is separated from the proximal position in the longitudinal direction of the tool bit (119) and the main handle (109) is biased by the biasing member (160) toward the separated position in the longitudinal direction of the tool bit (119),
and wherein the moving preventing part (109b) is provided with a first preventing portion (109b) which is arranged on the trigger (109a) and a second preventing portion which is arranged on the main handle (109),
in a state that the motor (111) is driven by manipulation of the trigger (109a), (i) when the main handle (109) is positioned in the proximal position, the second preventing portion engages with the switching member (171) and prevents the switching member (171) from moving to the intermediate position, and (ii) when the main handle (109) is positioned in the separated position, the first preventing portion (109b) engages with the switching member (171) and prevents the switching member (171) from moving to the intermediate position.
 5. The power tool according to claim 3, further comprising a trigger (109a) which is manually operated by a user for driving the motor (111), and an intervening member (180) which is arranged between the trigger (109a) and the switching member (171), the intervening member (180) being engageable with the trigger (109a) and the switching member (171) respectively,
wherein the moving preventing part (180) is provided by the intervening member (180).
 6. The power tool according to claim 5, further comprising a trigger switch (109c) which is fixed on the main handle (109) and operated by the trigger (109b), wherein the intervening member (180) is supported by the main handle (109) and/or the trigger switch (109c),
and wherein the intervening member (180) is configured to move integrally with the switching member (171) in a direction crossing the longitudinal direction of the tool bit (119) by engaging with the switching member (171) moving between the first position and the second position, and the intervening member (180) is configured to move with respect to the switching member (171) in the longitudinal direction of the tool bit (119) together with a relative movement between the main body (103) and the main handle (109).
 7. The power tool according to any one of claims 1 to 6, wherein the switching member (171) comprises a brush holding part (172, 174) which holds the brush (170), the brush holding part (172, 174) being movable around a rotational axis of the motor (111), and an operated part (175) which is connected to the brush holder part (172, 174), the operated part (175) being manually operated by a user,
and wherein the operated part (175) is provided such that the operated part (175) protrudes from the brush holding part (172, 174) in a direction perpendicular to the rotational axis of the motor (111).
 8. The power tool according to claim 7, wherein the interference avoidance part (165a, 165b) is provided with a through hole (165) which is formed on the main handle (109),
and wherein the operated part (175) is exposed to the outside of the power tool by extending through the through hole (165).
 9. The power tool according to claim 8, wherein the through hole (165) as the interference avoidance part (165a, 165b) is provided with a first interference avoidance part (165a) which extends in the longitudinal direction of the tool bit (119) for avoiding interference between the switching member (171) located in the first position and the main handle (109) and a second interference avoidance part (165b) which extends in the longitudinal direction of the tool bit (119) for avoiding interference between the switching member (171) located in the second position and the main handle (109),
and wherein the first interference avoidance part (165a) and the second interference avoidance part

(165b) are connected to each other.

Patentansprüche

1. Kraftwerkzeug, das dazu angepasst ist, ein Werkzeugbit (119) in einer Längsrichtung des Werkzeugbits (119) anzutreiben und einen Arbeitsvorgang auszuführen, mit
 - einem Antriebsmechanismus (113, 115, 117), der das Werkzeugbit (119) antreibt, einen Motor (111), der eine Bürste (170) aufweist und dazu konfiguriert ist, den Antriebsmechanismus (113, 115, 117) anzutreiben, bei dem eine Position der Bürste (170) selektiv in eine erste Drehposition, in welcher eine Drehwelle des Motors (111) in einer vorbestimmten ersten Richtung dreht, und eine zweite Drehposition geschaltet wird, in welcher die Drehwelle des Motors (111) in einer zu der ersten Richtung gegensätzlichen zweiten Richtung dreht,
 - einem Schaltbauteil (171), das manuell durch einen Benutzer zum Schalten der Position der Bürste (170) betätigt wird und zwischen einer ersten Position, welche die Bürste (170) in der ersten Drehposition positioniert, und einer zweiten Position bewegbar ist, welche die Bürste (170) in der zweiten Drehposition positioniert,
 - einem Hauptkörper (103), der den Antriebsmechanismus (113, 115, 117), den Motor (111) und das Schaltbauteil (171) hält, und
 - einem Haupthandgriff (109), der durch ein Vorspannbauteil (160) in der Längsrichtung des Werkzeugbits vorgespannt wird, das zwischen dem Hauptkörper (103) und dem Haupthandgriff (109) angeordnet ist, und der Haupthandgriff (109) ist relativ in Bezug auf den Hauptkörper (103) in einem Zustand bewegbar, in welchem das Vorspannbauteil (160) den Haupthandgriff (109) vorspannt, und die Vibration, die an dem Hauptkörper (103) während des Arbeitsvorganges erzeugt wird, wird an einer Übertragung an den Haupthandgriff (109) gehindert, bei dem
 - das Schaltbauteil durch einen Benutzer von der Außenseite des Haupthandgriffs (109) manipulierbar ist, und
 - der Haupthandgriff (109) einen Interferenzverhinderungsteil (165a, 165b) enthält, der eine Interferenz zwischen dem Schaltbauteil (171) und dem Haupthandgriff (109) verhindert, wenn das Schaltbauteil (171) in der ersten Position oder zweiten Position positioniert ist und der Haupthandgriff (109) in Bezug auf den Hauptkörper (103) bewegt wird.
2. Kraftwerkzeug nach Anspruch 1, bei dem die erste Position und die zweite Position jeweils als Position in einer Kreuzungsrichtung definiert sind, die die Längsrichtung des Werkzeugbits (119) kreuzt, und das Schaltbauteil (171) ist dazu konfiguriert, sich entlang der Kreuzungsrichtung zu bewegen, und bei dem der Haupthandgriff (109) dazu konfiguriert ist, sich in der Längsrichtung des Werkzeugbits (119) in Bezug auf den Hauptkörper (103) zu bewegen, und der Haupthandgriff (109) weist einen Eingriffsteil (165c) auf, der mit dem Schaltbauteil (171), das in einer Zwischenposition zwischen der ersten Position und der zweiten Position positioniert ist, eingreifbar ist,
 - und bei dem der Haupthandgriff (109) daran gehindert wird, sich in der Längsrichtung des Werkzeugbits (119) in Bezug auf den Hauptkörper (103) durch Eingriff des Schaltbauteils (171) mit dem Eingriffsteil (165c) zu bewegen.
3. Kraftwerkzeug nach Anspruch 1 oder 2, das weiter einen Bewegungsverhinderungsteil (109b; 180) aufweist, der verhindert, dass sich das Schaltbauteil (171) in eine Zwischenposition zwischen der ersten Position und der zweiten Position bewegt, wenn das Schaltbauteil (171) in der ersten Position oder der zweiten Position positioniert ist und der Motor (111) eingeschaltet ist.
4. Kraftwerkzeug nach Anspruch 3, das weiter einen Drücker (109a), der manuell durch einen Benutzer zum Antreiben eines Motors (111) betätigt wird, aufweist,
 - bei dem Haupthandgriff (109) dazu konfiguriert ist, sich zwischen einer proximalen Position, die proximal zu dem Werkzeugbit (119), und einer separierten Position, die von der proximalen Position in der Längsrichtung des Werkzeugbits (119) separiert ist, sich zu bewegen, und der Haupthandgriff (109) wird durch das Vorspannbauteil (160) in Richtung der separierten Position in der Längsrichtung der Werkzeugbits (119) vorgespannt,
 - und bei dem der Bewegungsverhinderungsteil (109b) mit einem ersten Verhinderungsteil (109b), der an dem Drücker (109a) angeordnet ist, und einen zweiten Verhinderungsteil vorgesehen ist, der an dem Haupthandgriff (109) angeordnet ist,
 - bei dem in einem Zustand, in dem der Motor durch Manipulation des Drückers (109a) angetrieben wird,
 - (i) wenn der Haupthandgriff (109) in der proximalen Position positioniert ist, der zweite Verhinderungsteil in Eingriff mit dem Schaltbauteil (171) steht und verhindert, dass sich das Schaltbauteil (171) zu der Zwischenposition bewegt, und
 - (ii) wenn der Haupthandgriff (109) in der separierten Position positioniert ist, der erste Verhinderungsteil (109b) mit dem Schaltbauteil (171) in Eingriff steht und verhindert, dass sich das Schaltbauteil (171) zu der Zwischenposition bewegt.
5. Kraftwerkzeug nach Anspruch 3, das weiter einen Drücker (109a), der durch einen Benutzer zum Antreiben des Motors (111) manuell betätigt wird, und

ein Zwischenbauteil (180) aufweist, das zwischen dem Drücker (109a) und dem Schaltbauteil (191) angeordnet ist, bei dem das Zwischenbauteil (180) mit dem Drücker (109a) bzw. dem Schaltbauteil (171) eingreifbar ist, bei dem der Bewegungsverhinderungsteil (180) bei dem Zwischenbauteil (180) vorgesehen ist.

6. Kraftwerkzeug nach Anspruch 5, das weiter einen Drückerschalter (109c) aufweist, der an dem Haupt-handgriff (109) fixiert ist und durch den Drücker (109b) betätigt wird, bei dem das Zwischenbauteil (180) durch den Haupt-handgriff (109) und/oder den Drückerschalter (109c) gelagert wird, und bei dem das Zwischenbauteil (180) dazu konfiguriert ist, sich integral mit dem Schaltbauteil (171) in einer Richtung, die die Längsrichtung des Werkzeugbits (119) kreuzt, durch Eingriff mit dem Schaltbauteil (171), das sich zwischen der ersten und der zweiten Position bewegt, zu bewegen, und das Zwischenbauteil (180) dazu konfiguriert ist, sich in Bezug auf Schaltbauteil (171) in der Längsrichtung des Werkzeugbits (119) zusammen mit einer relativen Bewegung zwischen dem Hauptkörper (103) und dem Haupthandgriff (109) zu bewegen.
7. Kraftwerkzeug nach einem der Ansprüche 1 bis 6, bei dem das Schaltbauteil (171) einen Bürstenhalterungsteil (172, 174), der die Bürste (170) hält, bei dem der Bürstenhalterungsteil (172, 174) um eine Drehachse des Motors (111) bewegbar ist, und einen betätigten Teil (175) aufweist, der mit dem Bürstenhalterungsteil (172, 174) verbunden ist, bei dem der betätigte Teil (175) durch einen Benutzer manuell betätigt wird, und bei dem der betätigte Teil (175) vorgesehen ist, so dass der betätigte Teil (175) von dem Bürstenhalterungsteil (172, 174) in einer Richtung senkrecht zu der Drehachse des Motors (111) vorsteht.
8. Kraftwerkzeug nach Anspruch 7, bei der Interferenzverhinderungsteil (165a, 165b) mit einem Durchgangsloch (165) vorgesehen ist, das an dem Haupt-handgriff (109) ausgebildet ist, und bei dem der betätigte Teil (175) zu der Außenseite des Kraftwerkzeuges freigelegt ist, indem er sich durch das Durchgangsloch (165) erstreckt.
9. Kraftwerkzeug nach Anspruch 8, bei dem das Durchgangsloch (165) als der Interferenzverhinderungsteil (165a, 165b) mit einem ersten Interferenzverhinderungsteil (165a), der sich in der Längsrichtung des Werkzeugbits (119) zum Verhindern einer Interferenz zwischen dem Schaltbauteil (171), das sich in der ersten Position befindet, und dem Haupthandgriff (109) erstreckt, und einem weiteren Interferenzverhinderungsteil (165) vorgesehen ist, der sich in

der Längsrichtung des Werkzeugbits (119) zum Verhindern der Interferenz zwischen dem Schaltbauteil (171), das sich in der zweiten Position befindet, und dem Haupthandgriff (109) erstreckt, bei dem der erste Interferenzverhinderungsteil (165a) und der zweite Interferenzverhinderungsteil (165b) miteinander verbunden sind.

10 Revendications

1. Outil électrique qui est adapté pour entraîner un foret (119) d'outil dans une direction longitudinale du foret (119) d'outil et effectuer une opération, comprenant :

un mécanisme d'entraînement (113, 115, 117) qui entraîne le foret (119) d'outil, un moteur (111) qui comporte un balai (170) et est configuré pour entraîner le mécanisme d'entraînement (113, 115, 117), une position du balai (170) étant sensiblement commutée dans une première position de rotation dans laquelle un arbre rotatif du moteur (111) tourne dans une première direction prédéterminée et une seconde position de rotation dans laquelle l'arbre rotatif du moteur (111) tourne dans une seconde direction opposée à la première direction, un élément de commutation (171) qui est manuellement actionné par un utilisateur pour commuter la position du balai (170) et est mobile entre une première position qui positionne le balai (170) dans la première position de rotation et une seconde position qui positionne le balai (170) dans la seconde position de rotation, un corps principal (103) qui maintient le mécanisme d'entraînement (113, 115, 117), le moteur (111) et l'élément de commutation (171), et une poignée principale (109) qui est sollicitée par un élément de sollicitation (160) dans la direction longitudinale du foret d'outil, qui est agencé entre le corps principal (103) et la poignée principale (109), et la poignée principale (109) est relativement mobile par rapport au corps principal (103) dans un état où l'élément de sollicitation (160) sollicite la poignée principale (109), et la vibration causée sur le corps principal (103) durant le fonctionnement ne peut pas être transmises à la poignée principale (109),

dans lequel

l'élément de commutation peut être manipulé par un utilisateur depuis l'extérieur de la poignée principale (109), et la poignée principale (109) inclut une partie d'évitement d'interférence (165a, 165b) qui évi-

- te l'interférence entre l'élément de commutation (171) et la poignée principale (109) quand l'élément de commutation (171) est positionné dans la première position ou la seconde position et la poignée principale (109) est déplacée par rapport au corps principal (103).
2. Outil électrique selon la revendication 1, dans lequel la première position et la seconde position sont définies en tant que chaque position dans une direction de croisement croisant la direction longitudinale du foret (119) d'outil et l'élément de commutation (171) est configuré pour se déplacer dans la direction de croisement, et dans lequel la poignée principale (109) est configurée pour se déplacer dans la direction longitudinale du foret (119) d'outil par rapport au corps principal (103) et la poignée principale (109) possède une partie d'entrée en prise (165c) qui peut entrer en prise avec l'élément de commutation (171) positionné dans une position intermédiaire entre la première position et la seconde position, et dans lequel la poignée principale (109) ne peut pas se déplacer dans la direction longitudinale du foret (119) d'outil par rapport au corps principal (103) par l'entrée en prise de l'élément de commutation (171) et la partie d'entrée en prise (165c).
 3. Outil électrique selon la revendication 1 ou 2, comprenant en outre une partie d'empêchement de déplacement (109b; 180) qui empêche l'élément de commutation (171) de se déplacer vers une position intermédiaire entre la première position et la seconde position quand l'élément de commutation (171) est positionné dans la première position ou la seconde position et que le moteur (111) est allumé.
 4. Outil électrique selon la revendication 3, comprenant en outre une gâchette (109a) qui est manuellement actionnée par un utilisateur pour entraîner le moteur (111), dans lequel la poignée principale (109) est configurée pour se déplacer entre une position proximale qui est proximale par rapport au foret (119) d'outil et une position séparée qui est séparée de la position proximale dans la direction longitudinale du foret (119) d'outil et la poignée principale (109) est sollicitée par l'élément de sollicitation (160) vers la position séparée dans la direction longitudinale du foret (119) d'outil, et dans lequel la partie d'empêchement de déplacement (109b) est pourvue d'une première portion d'empêchement (109b) qui est agencé sur la gâchette (109a) et d'une seconde portion d'empêchement qui est agencée sur la poignée principale (109), dans un état où le moteur (111) est entraîné par manipulation de la gâchette (109a), (i) quand la poignée principale (109) est positionnée dans la position proximale, la seconde portion d'empêchement entre en prise avec l'élément de commutation (171) et empêche l'élément de commutation (171) de se déplacer vers la position intermédiaire, et (ii) quand la poignée principale (109) est positionnée dans la position séparée, la première portion d'empêchement (109b) entre en prise avec l'élément de commutation (171) et empêche l'élément de commutation (171) de se déplacer vers la position intermédiaire.
 5. Outil électrique selon la revendication 3, comprenant en outre une gâchette (109a) qui est manuellement actionnée par un utilisateur pour entraîner le moteur (111), et un élément d'intervention (180) qui est agencé entre la gâchette (109a) et l'élément de commutation (171), l'élément d'intervention (180) pouvant entrer en prise avec la gâchette (109a) et l'élément de commutation (171), respectivement, dans lequel la partie d'empêchement de déplacement (180) est procurée par l'élément d'intervention (180).
 6. Outil électrique selon la revendication 5, comprenant en outre un commutateur (109c) de gâchette qui est fixé sur la poignée principale (109) et actionnée par la gâchette (109b), dans lequel l'élément d'intervention (180) est supporté par la poignée principale (109) et/ou le commutateur (109c) de gâchette, et dans lequel l'élément d'intervention (180) est configuré pour se déplacer d'un seul tenant avec l'élément de commutation (171) dans une direction croisant la direction longitudinale du foret (119) d'outil par l'entrée en prise avec l'élément de commutation (171) se déplaçant entre la première position et la seconde position, et l'élément d'intervention (180) est configuré pour se déplacer par rapport à l'élément de commutation (171) dans la direction longitudinale du foret (119) d'outil avec un déplacement relatif entre le corps principal (103) et la poignée principale (109).
 7. Outil électrique selon l'une quelconque des revendications 1 à 6, dans lequel l'élément de commutation (171) comprend une partie de maintien (172, 174) de balai qui maintient le balai (170), la partie de maintien (172, 174) de balai étant mobile autour d'un axe de rotation du moteur (111), et une partie actionnée (175) qui est reliée à la partie de maintien (172, 174) de balai, la partie actionnée (175) étant manuellement actionnée par un utilisateur, et dans lequel la partie actionnée (175) est disposée de telle sorte que la partie actionnée (175) fait saillie depuis la partie de maintien (172, 174) de balai dans une direction perpendiculaire à l'axe de rotation du moteur (111).
 8. Outil électrique selon la revendication 7, dans lequel

la partie d'évitement d'interférence (165a, 165b) est pourvue d'un trou débouchant (165) qui est formé sur la poignée principale (109), et dans lequel la partie actionnée (175) est exposée à l'extérieur de l'outil électrique en s'étendant à travers le trou débouchant (165). 5

9. Outil électrique selon la revendication 8, dans lequel le trou débouchant (165) en tant que partie d'évitement d'interférence (165a, 165b) est pourvu d'une première partie d'évitement d'interférence (165a) qui s'étend dans la direction longitudinale du foret (119) d'outil pour éviter l'interférence entre l'élément de commutation (171) situé dans la première position et la poignée principale (109) et une seconde partie d'évitement d'interférence (165b) qui s'étend dans la direction longitudinale du foret (119) d'outil pour éviter l'interférence entre l'élément de commutation (171) situé dans la seconde position et la poignée principale (109), dans lequel la première partie d'évitement d'interférence (165a) et la seconde partie d'évitement d'interférence (165b) sont reliées l'une à l'autre. 10 15 20

25

30

35

40

45

50

55

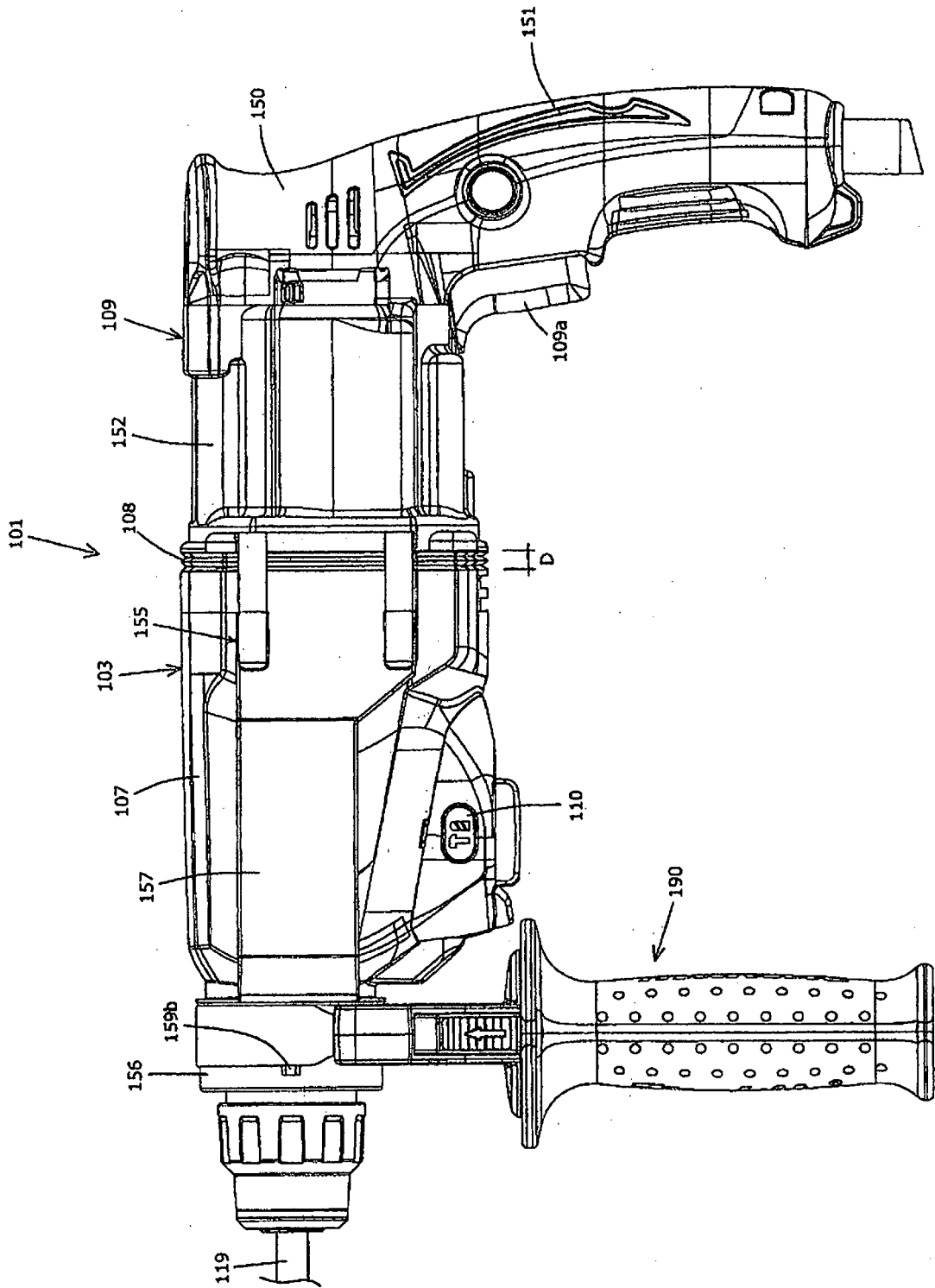

FIG. 1

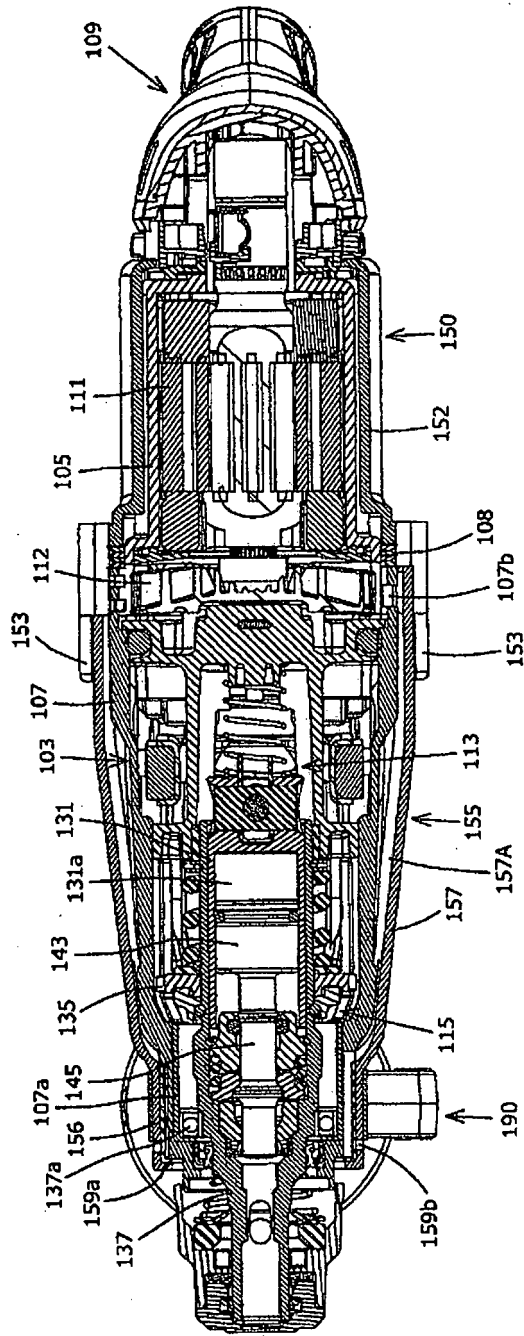

FIG.3

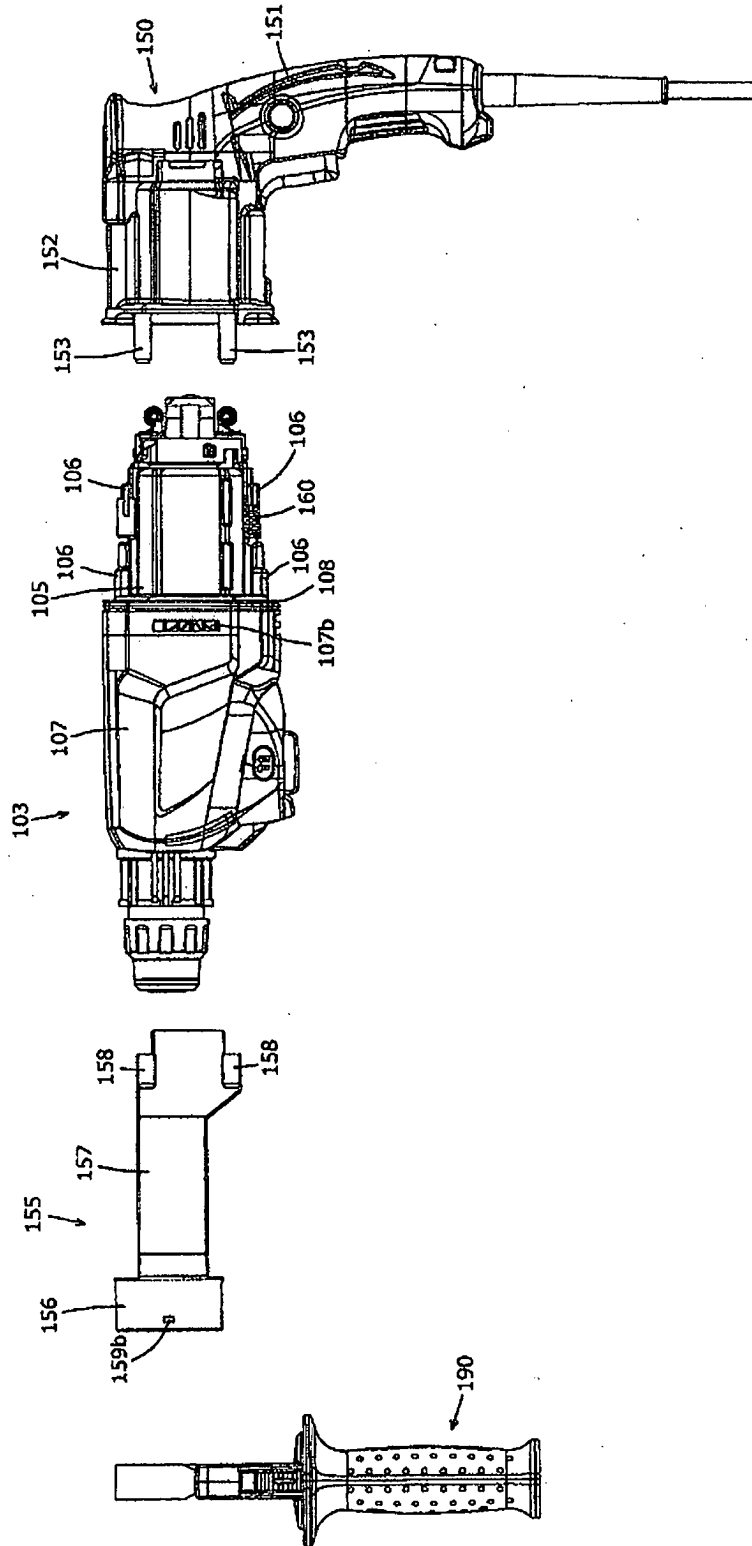

FIG.4

FIG. 5

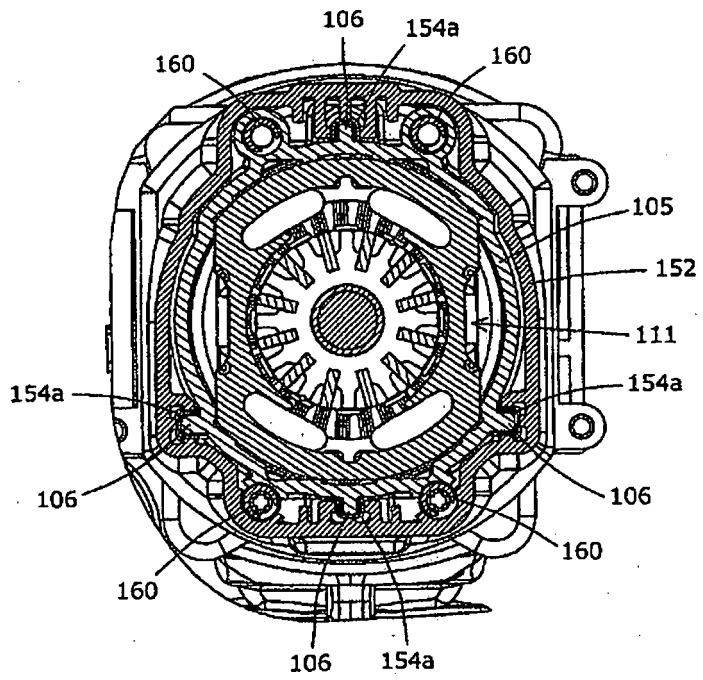

FIG. 6

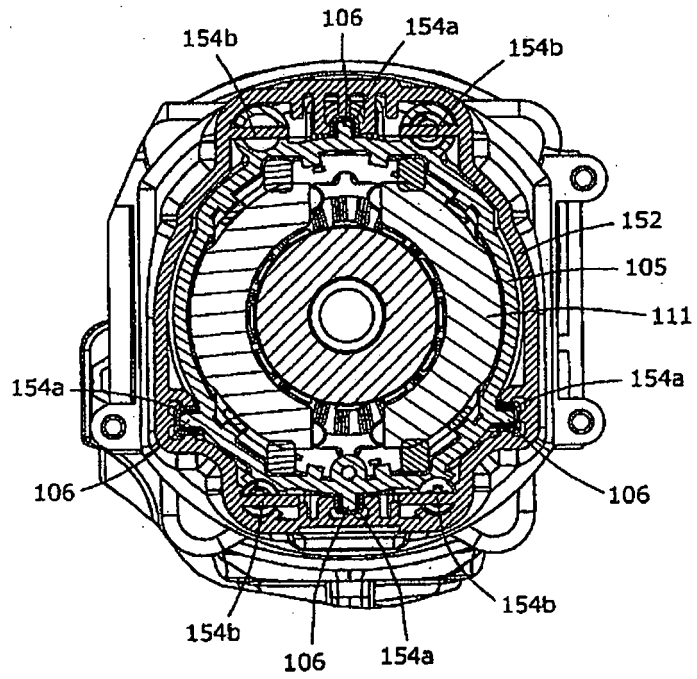
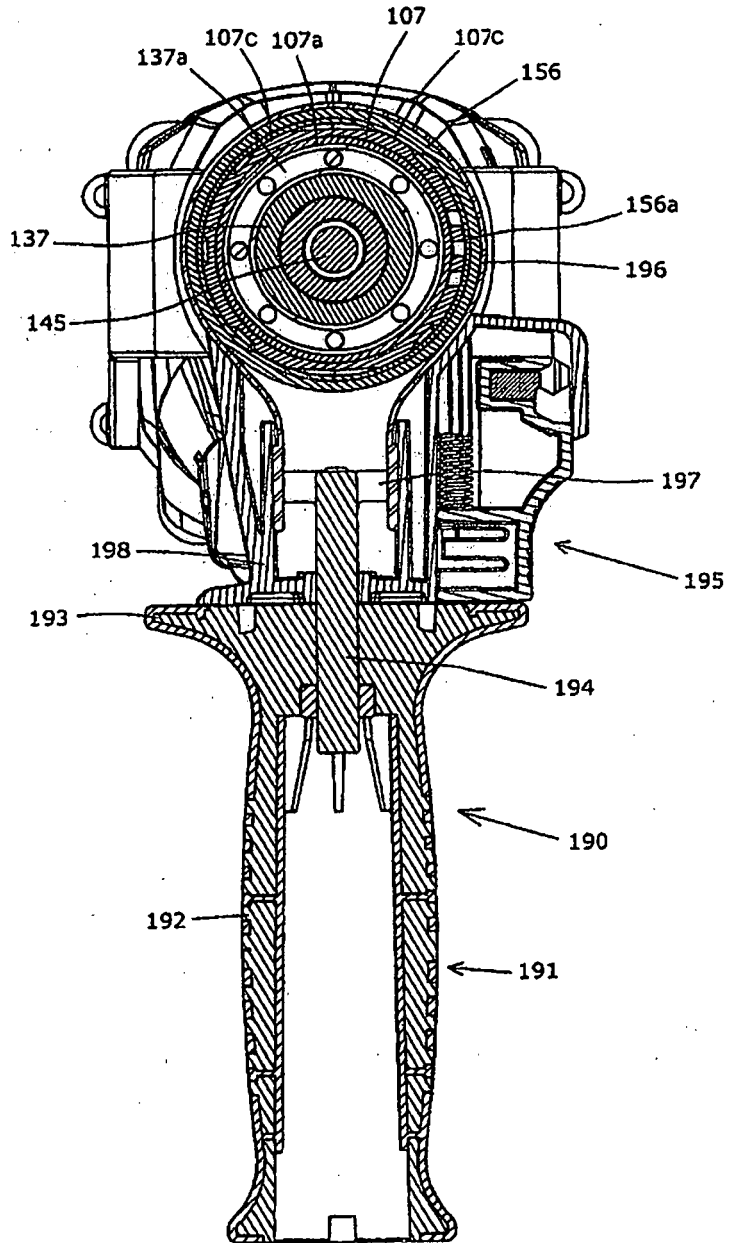

FIG. 7



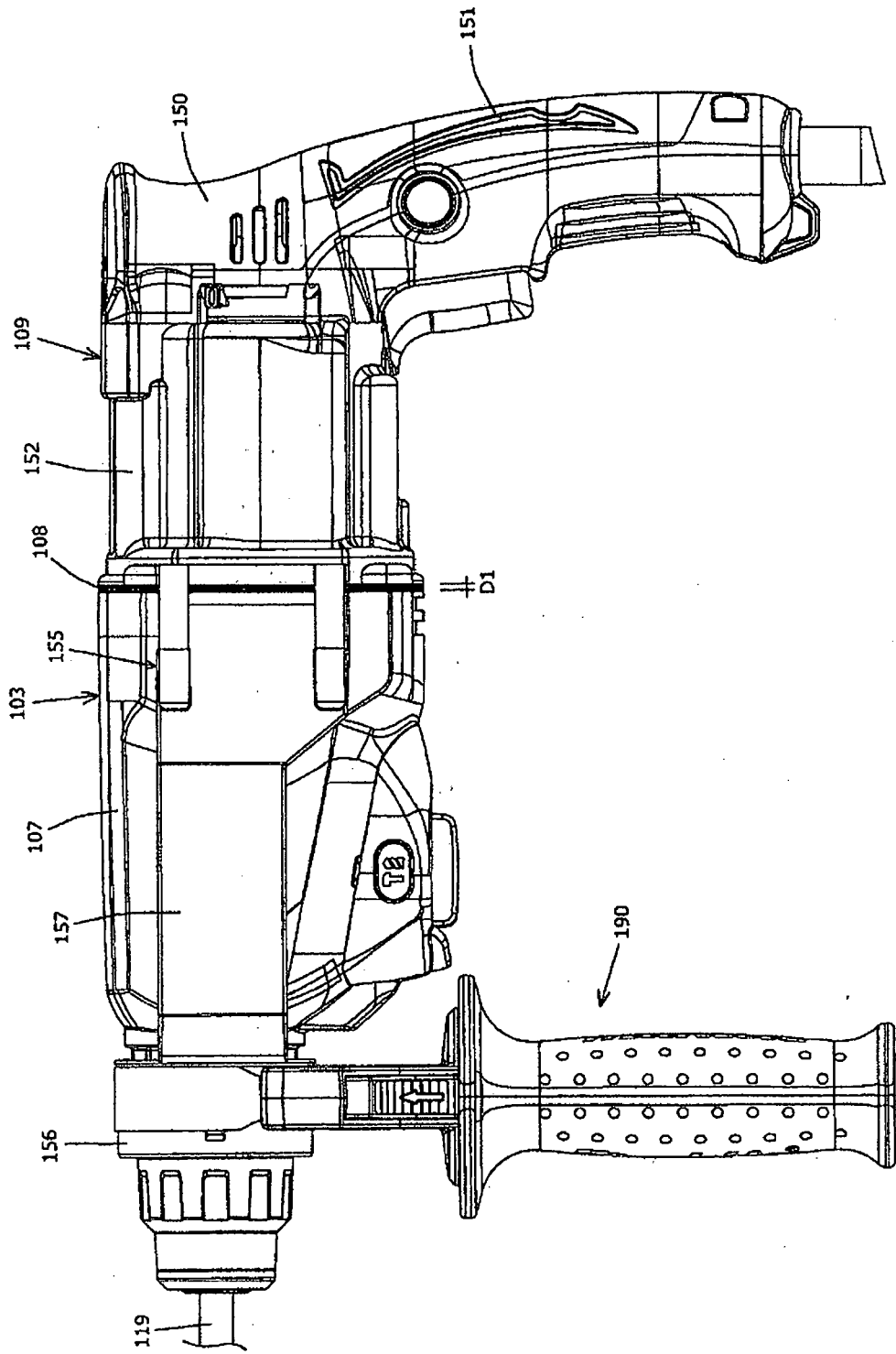

FIG. 8

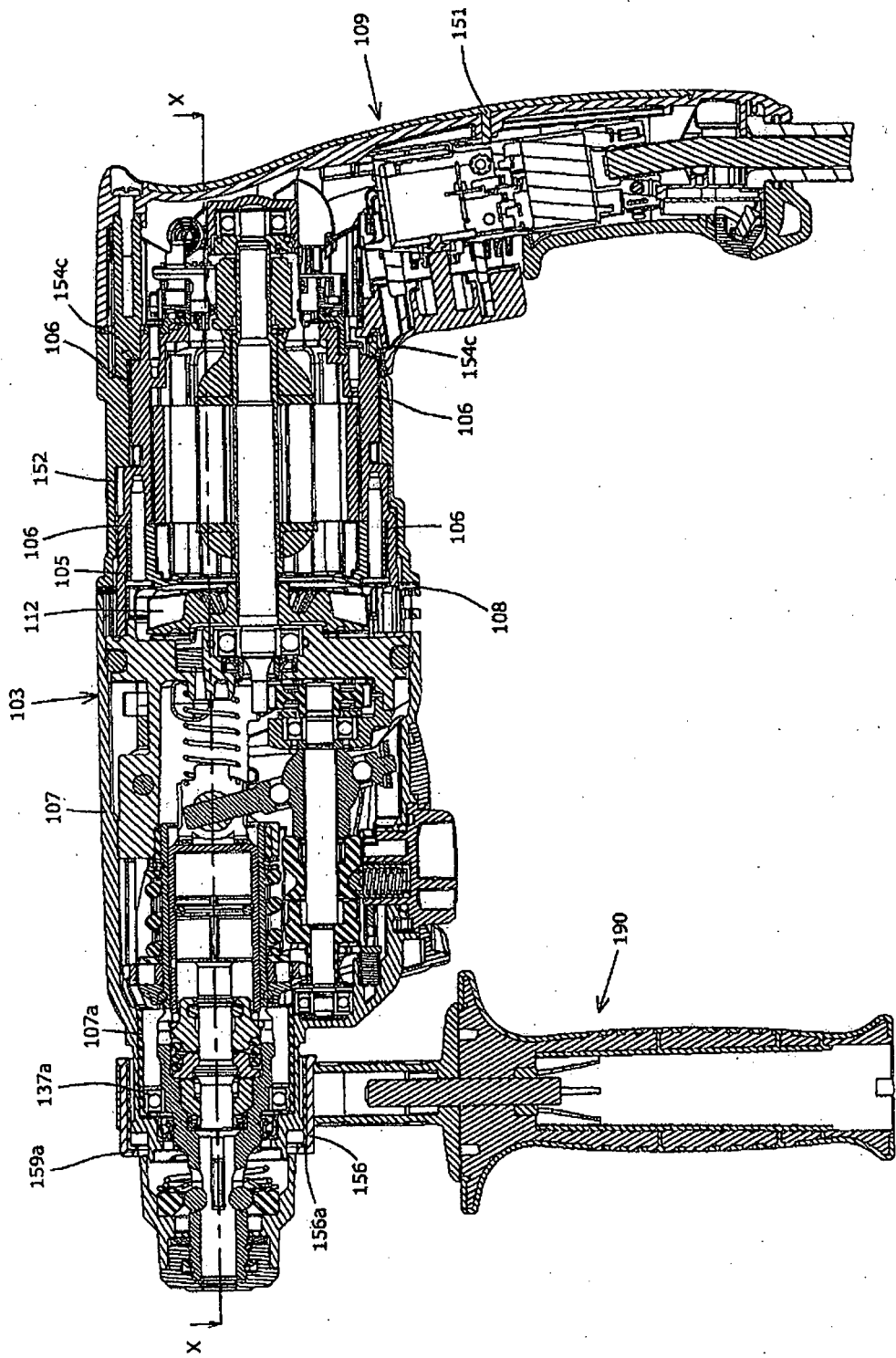

FIG. 9

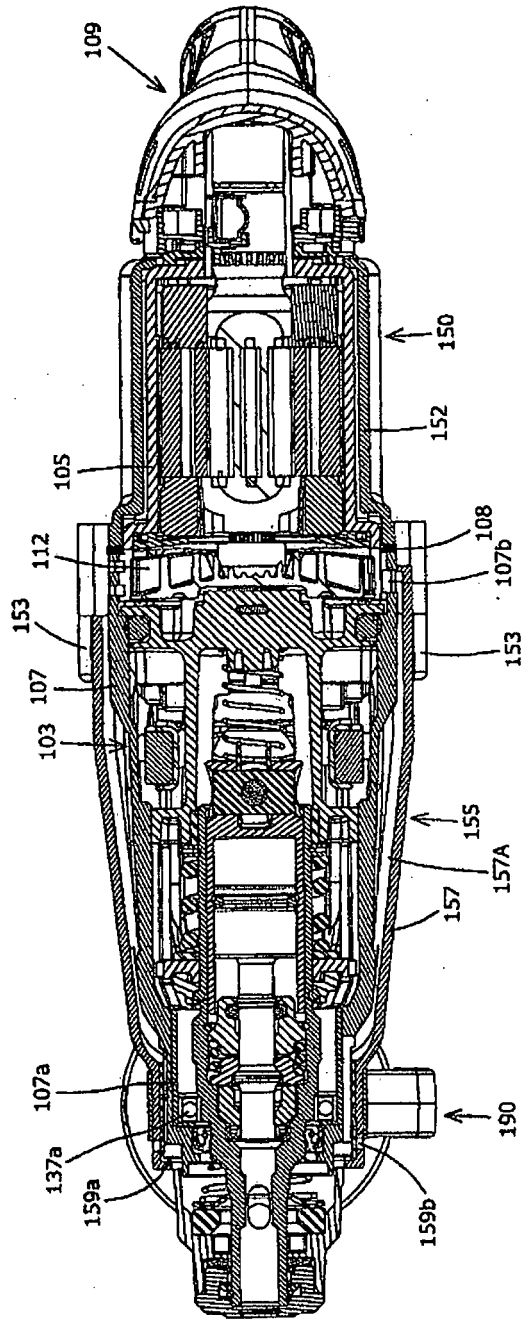

FIG. 10

FIG. 11

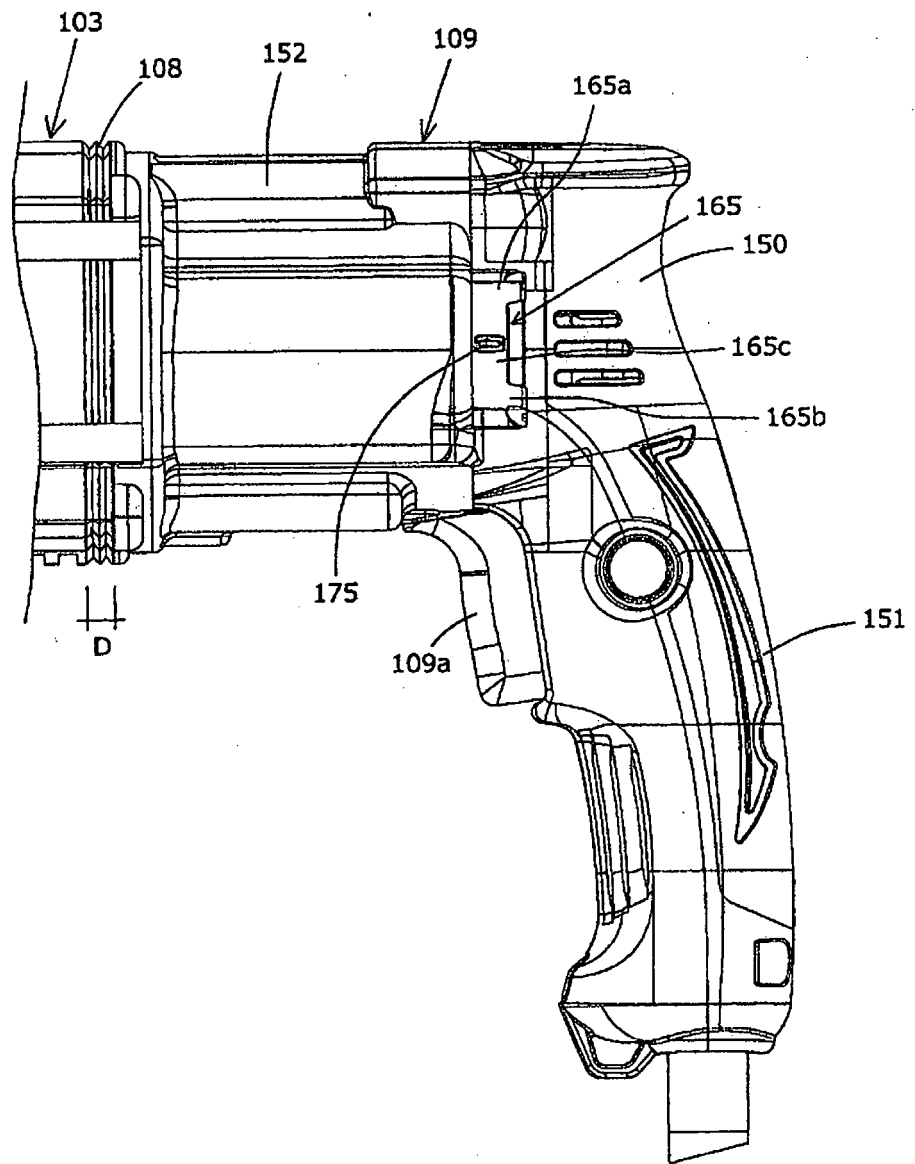

FIG. 12

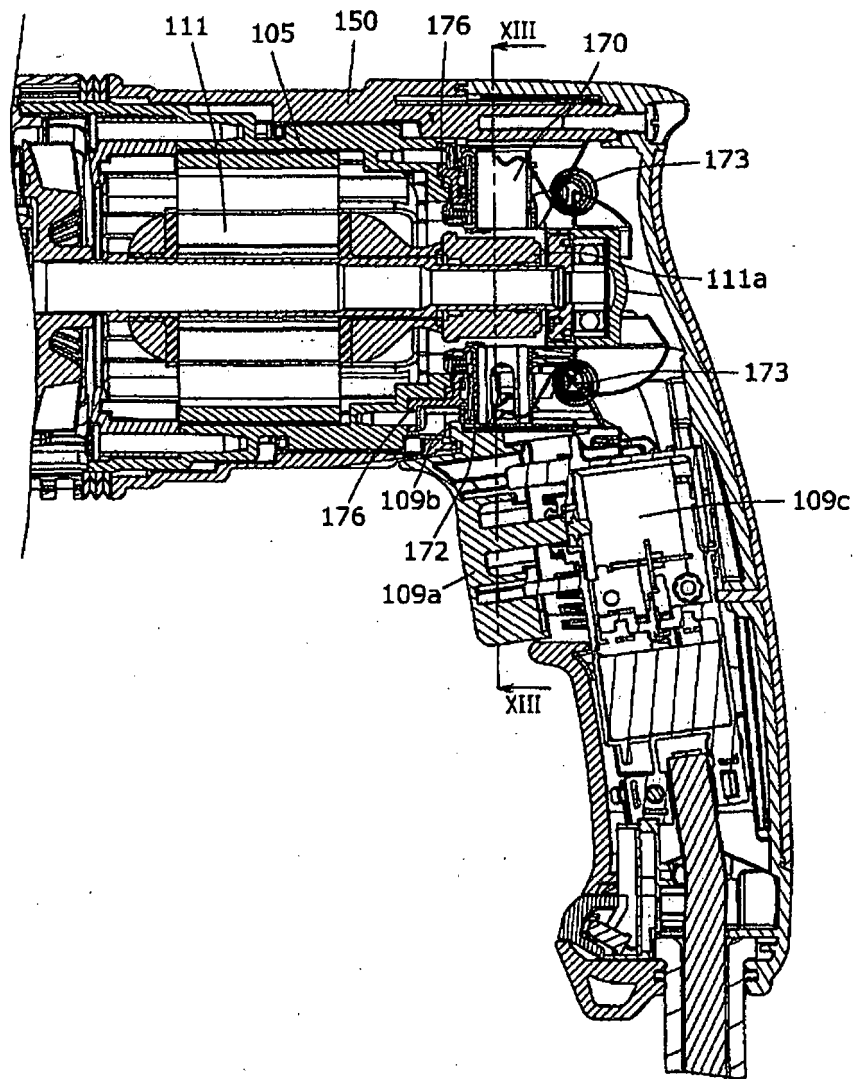

FIG. 13

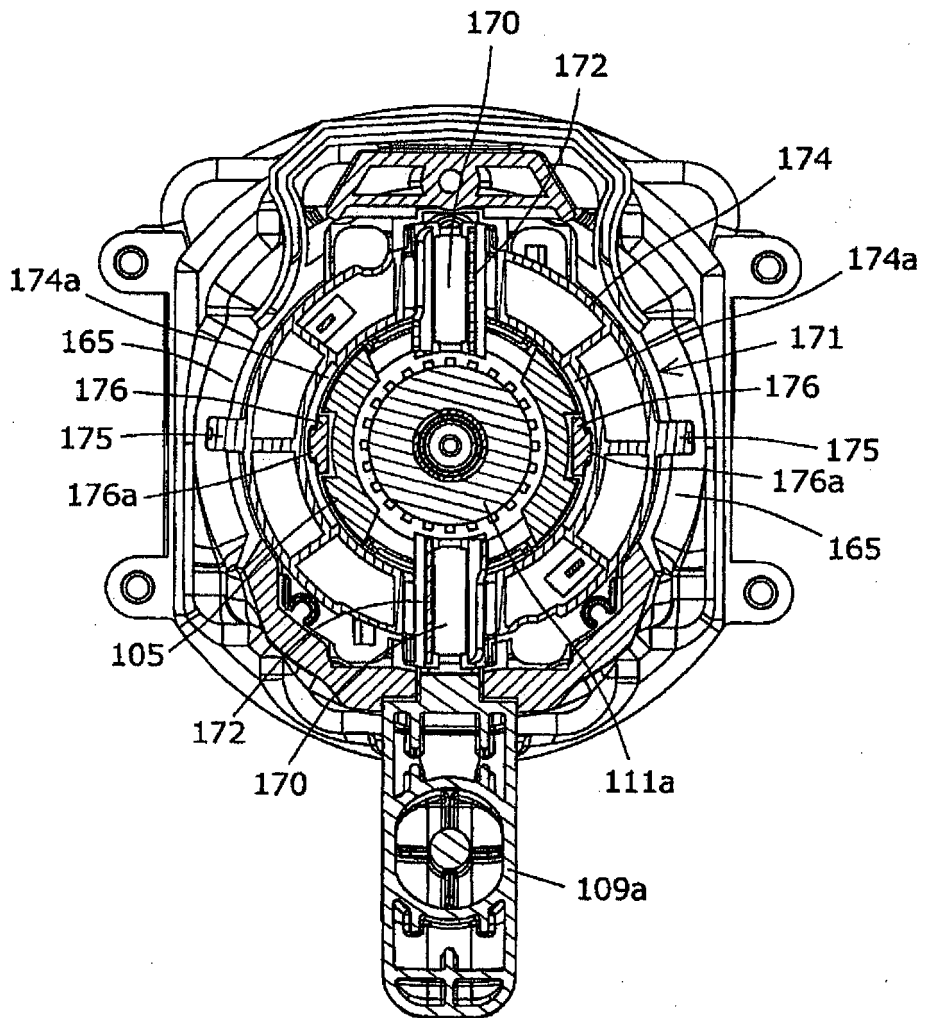

FIG. 15

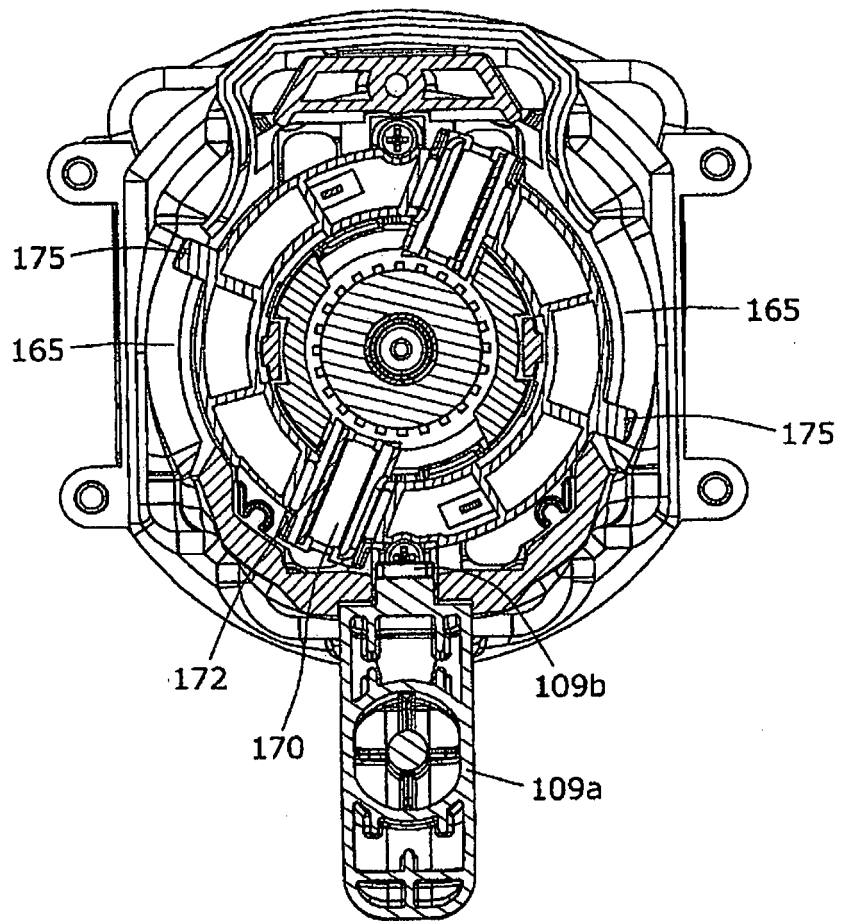

FIG. 16

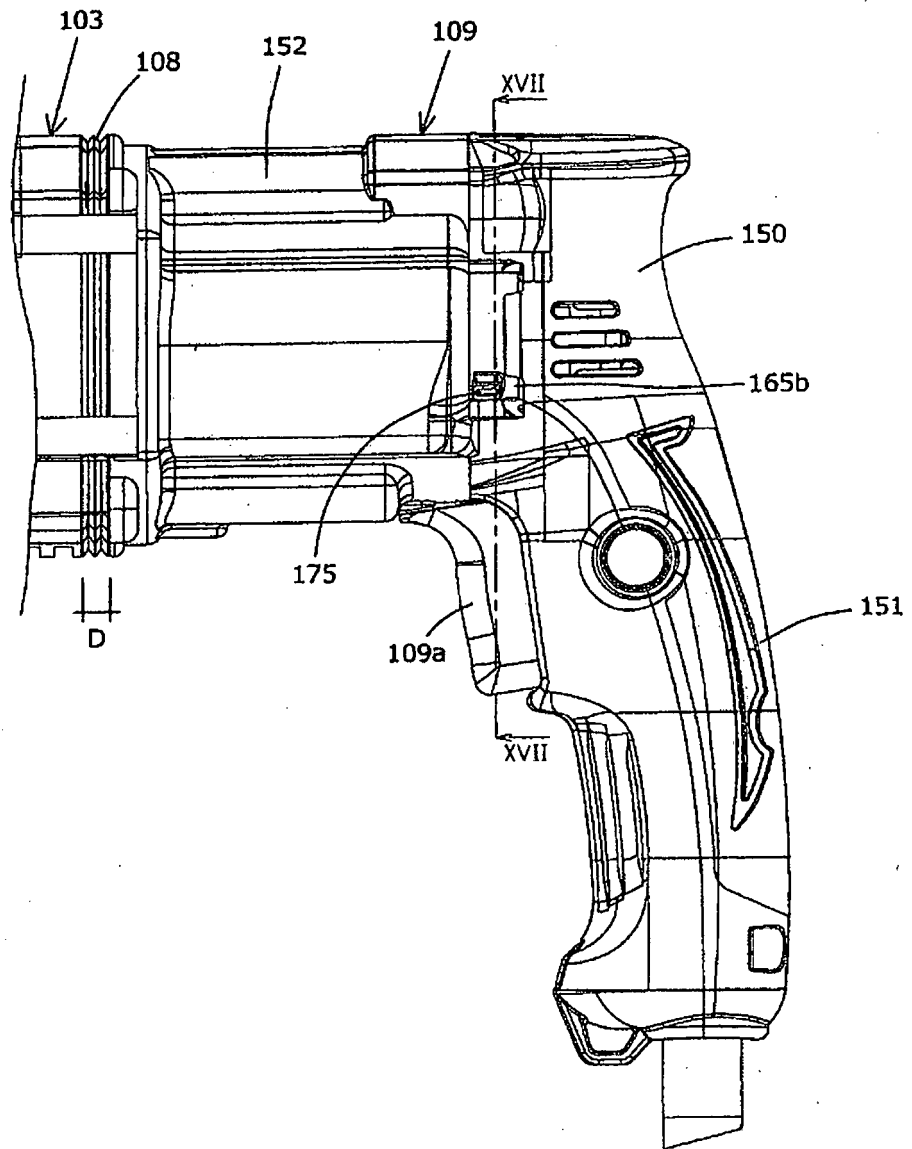

FIG. 17

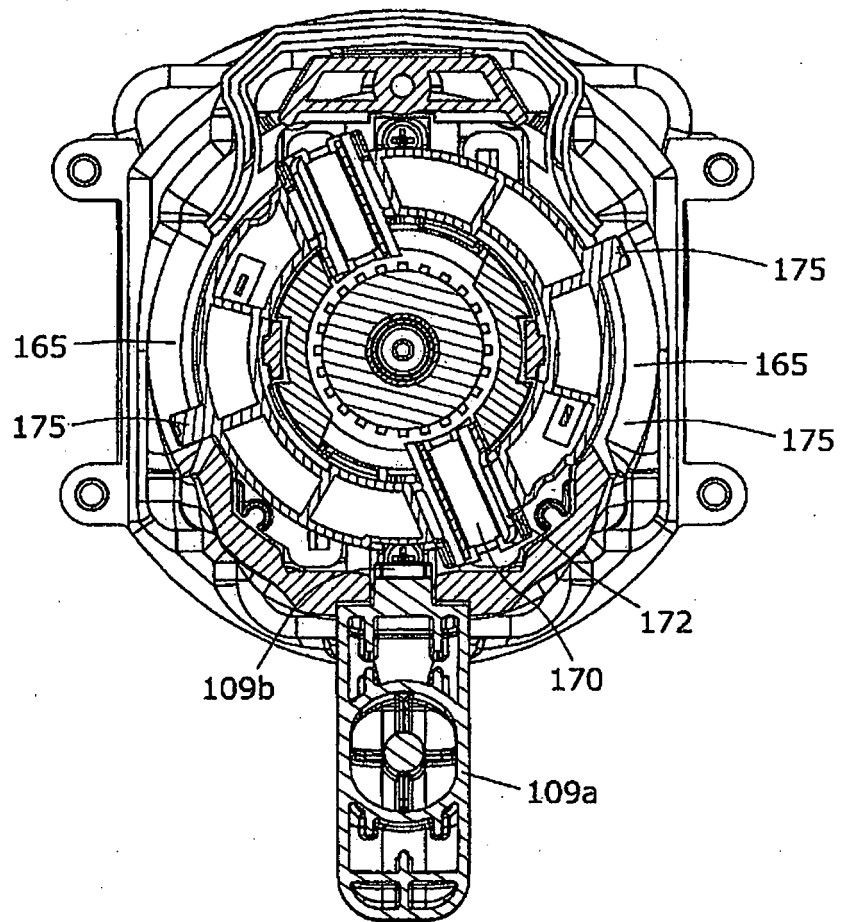

FIG. 19

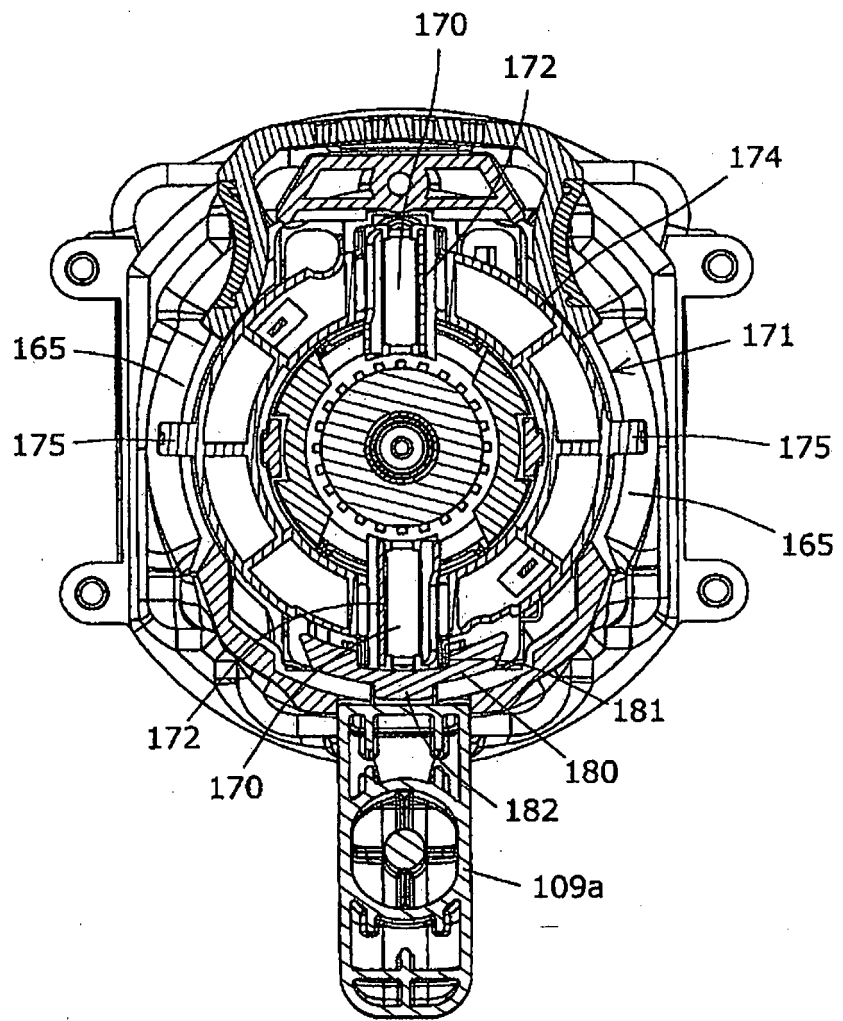

FIG. 20

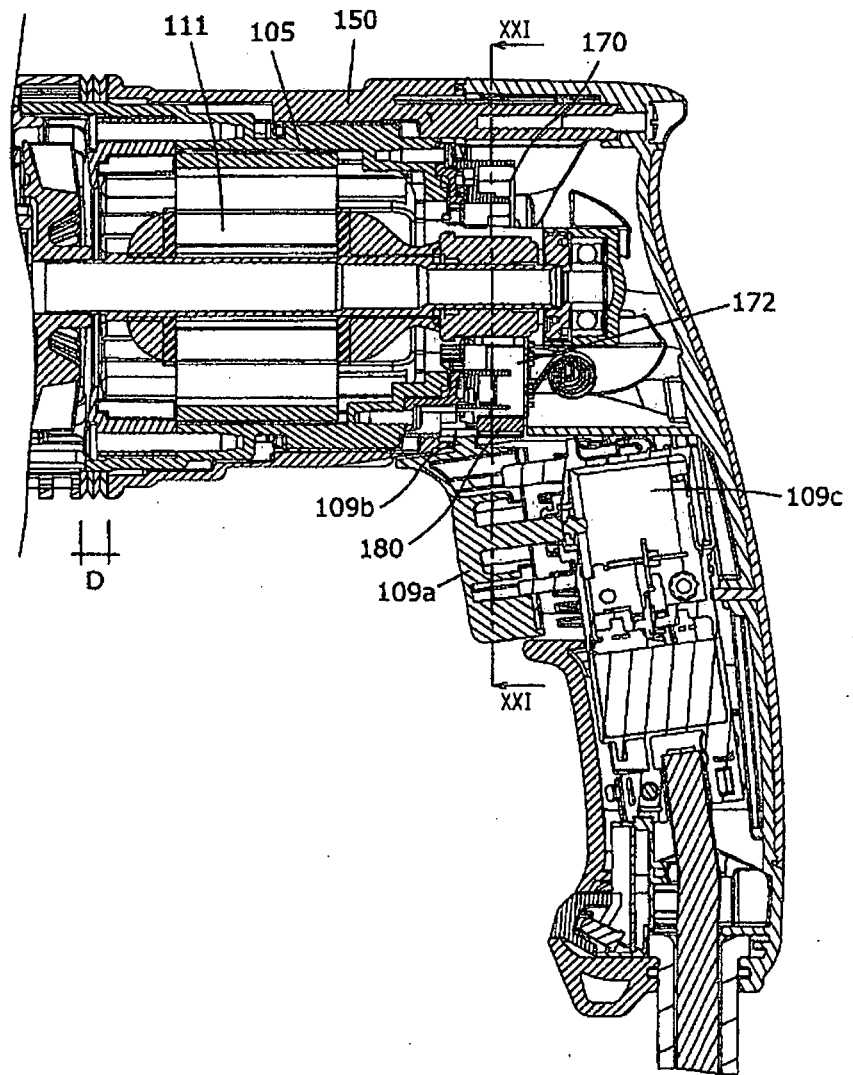

FIG. 21

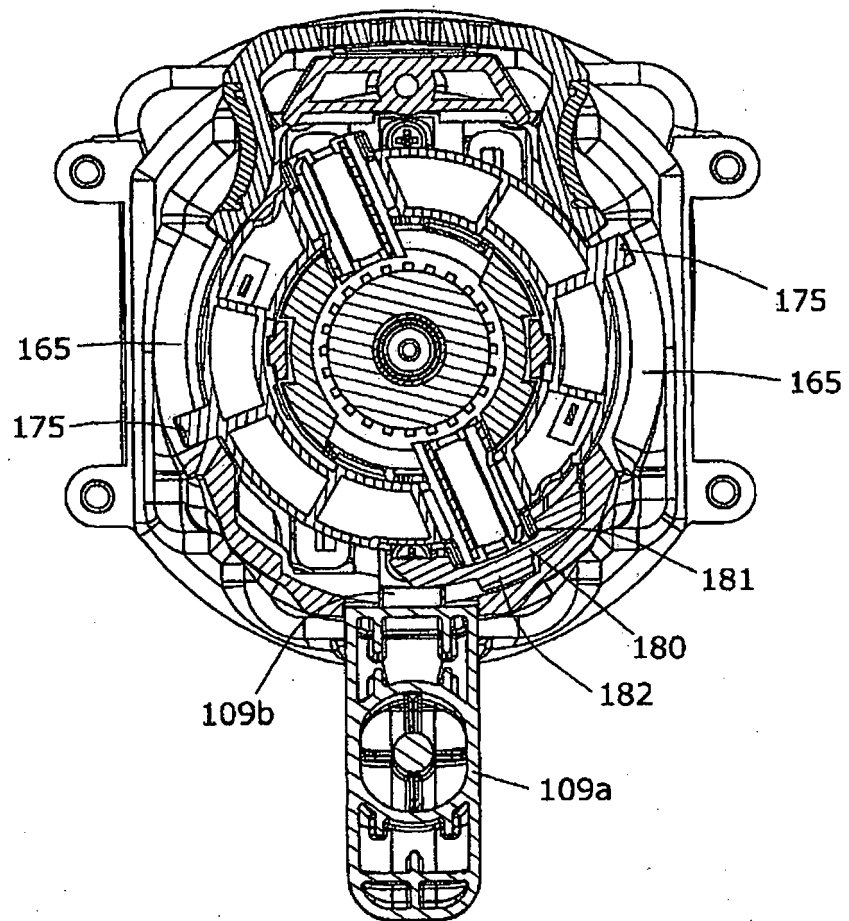
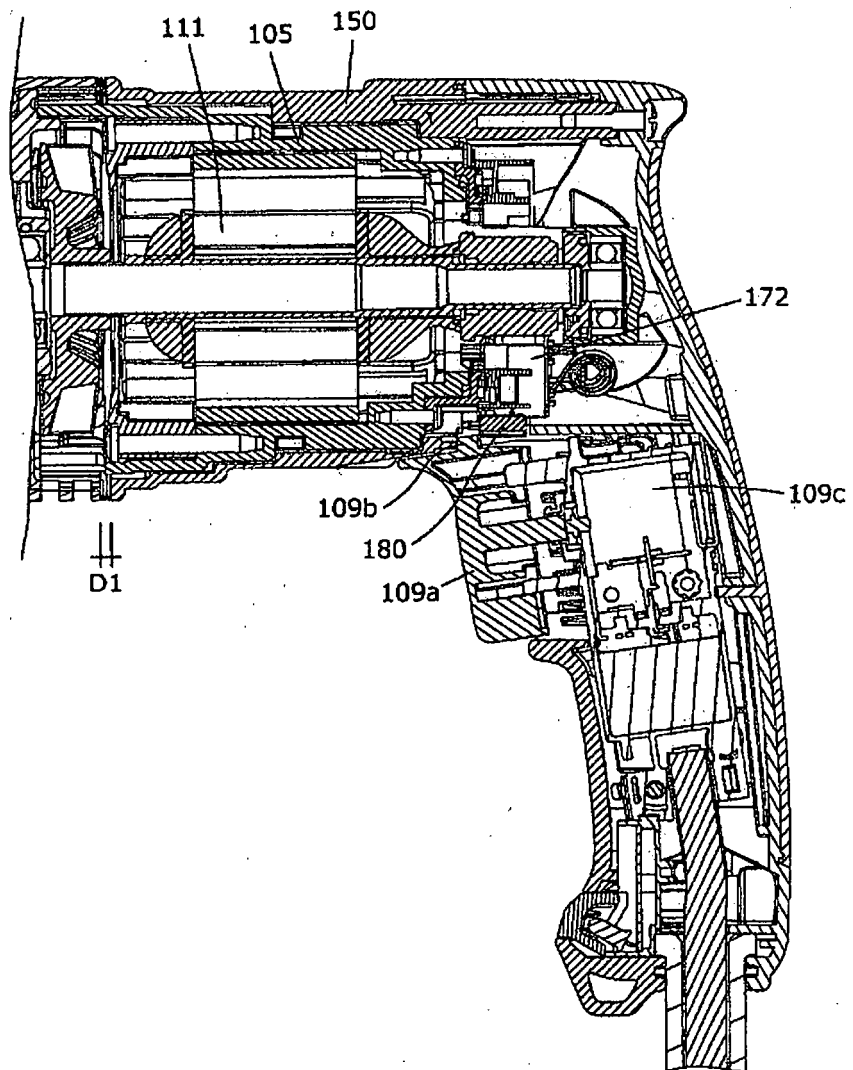

FIG. 22



REFERENCES CITED IN THE DESCRIPTION

This list of references cited by the applicant is for the reader's convenience only. It does not form part of the European patent document. Even though great care has been taken in compiling the references, errors or omissions cannot be excluded and the EPO disclaims all liability in this regard.

Patent documents cited in the description

- WO 2007068535 A [0002]