



(11) **EP 2 884 034 B1**

(12) **EUROPEAN PATENT SPECIFICATION**

(45) Date of publication and mention of the grant of the patent:
12.10.2016 Bulletin 2016/41

(51) Int Cl.:
E06B 3/273 (2006.01) **E06B 1/12 (2006.01)**
E06B 1/32 (2006.01)

(21) Application number: **14195861.1**

(22) Date of filing: **02.12.2014**

(54) **Frame for metal doors**

Rahmen für Metalltüren

Cadre pour portes métalliques

(84) Designated Contracting States:
AL AT BE BG CH CY CZ DE DK EE ES FI FR GB GR HR HU IE IS IT LI LT LU LV MC MK MT NL NO PL PT RO RS SE SI SK SM TR

(30) Priority: **16.12.2013 IT VE20130067**

(43) Date of publication of application:
17.06.2015 Bulletin 2015/25

(73) Proprietor: **DALLAN S.P.A.**
31033 Castelfranco Veneto (IT)

(72) Inventor: **Dallan, Andrea**
31033 Castelfranco Veneto (IT)

(74) Representative: **Piovesana, Paolo**
Via F. Baracca, 5/a
30173 Venezia-Mestre (IT)

(56) References cited:
EP-A1- 0 460 444 NL-C2- 1 003 974
US-A- 4 930 257

EP 2 884 034 B1

Note: Within nine months of the publication of the mention of the grant of the European patent in the European Patent Bulletin, any person may give notice to the European Patent Office of opposition to that patent, in accordance with the Implementing Regulations. Notice of opposition shall not be deemed to have been filed until the opposition fee has been paid. (Art. 99(1) European Patent Convention).

Description

[0001] The present invention relates to a frame for metal doors.

[0002] Metal frames are known for metal doors consisting of a single piece of U-bent sheet metal, connected to the masonry and comprising on one side the hinges and on the other side the holes for the locks and for the hinges.

[0003] In fire door applications, and with the purpose of improving thermal insulation, metal frames have been produced with doors consisting of two pieces of bent metal which are joined together via a gasket of plastic material of lesser thermal conductivity.

[0004] By achieving this purpose, the heat insulation and cold insulation from one side to the other of the piece of sheet metal is further improved.

[0005] This type of frame involves however considerable labour during installation, considerable complication during production, and a high final cost of the industrial product obtained.

[0006] The objects of the invention are to eliminate these drawbacks by providing for doors, a metal frame which can be produced simply and comfortably, which presents a very low thermal conductivity between the inside and outside of the environment, and which at the same time is of pleasant appearance from the outside.

[0007] NI 1003 974 C2 relates to a frame for metal doors with the features of the preamble of claim 1, having a first wall section and on the longitudinal rims two wall sections at right angles. Bend rim stretches parallel with wall section. On the side of wall section, wall section is parallel with protruding wall section.

[0008] These objects are attained according to the invention by a frame for metal doors, as described in claim 1.

[0009] A preferred embodiment of the invention is further clarified hereinafter with reference to the accompanying drawings, in which:

Figure 1 is a plan view of a piece of sheet metal for obtaining the frame according to the invention, and Figure 2 shows the frame obtained.

[0010] As can be seen from the figures, the metal frame for metal doors is formed starting from a single piece of sheet metal 2 which along a longitudinal band thereof is provided with a plurality of apertures 4.

[0011] In the illustrated example, the apertures consist of slotted holes which can be formed by removal or by expansion (cutting and stretching the material).

[0012] The piece of sheet metal is bent and U-shaped to form, by means of its arms, the flanges 6 for connection to the masonry 8 and, by means of its base 10, two portions 12, 12' parallel to each other and to the edge 14 of the masonry and a central portion 16 which with the portion 12' forms a step acting as the striker for the movable door leaf (not shown in the drawing).

[0013] In particular, at this step the piece of sheet metal is bent over to form a lip 18 obtained by coupling together two facing ledges 20, 20', one 20 of which, namely that closer to the side of the masonry, consists of the longitudinal band with apertures 4.

[0014] An insulating gasket 22 of insulation material is interposed between the two ledges 20, 20'.

[0015] From the foregoing it is apparent that the frame according to the invention presents numerous advantages, and in particular:

- a constructional simplicity achieved by the facility to form the apertured band during the actual profiling stage,
- a low coefficient of thermal conductivity between the outside and inside by virtue of the slotted holes 4 which substantially reduce the metal cross-section through which the heat is transmitted,
- a pleasant appearance in that the apertured band is not visible from the outside,
- a lengthening of the path which the heat has to take in passing from the inside to the outside of the profile.

[0016] Moreover, the insulating gasket 22 prevents contact between the ledge 20 comprising the slotted holes 4 and the ledge 20' which faces it, so as to prevent the heat being able to be transmitted by direct conduction in case of their contact.

[0017] The present invention also extends to other similar profiles in which thermal conduction must be reduced between two parts of the profile in a direction perpendicular to the profile axis, such as window frames, continuous façade profiles, or other construction profiles.

Claims

1. A frame for metal doors and consisting of a single piece (2) of sheet metal bent to U-shape with its arms (6) fixable to the masonry and with its base (10) disposed parallel to the edge (14) of the masonry (8), said base (10) being provided with at least one lip (18) parallel to the base and facing the edge (14) of the masonry, said lip being obtained by bending over the piece of sheet metal AND coupling together two facing ledges (20, 20'), with an insulating gasket (22) being positioned between said ledges **characterised in that** at least one of the ledges (20, 20') is provided with a plurality of holes (4), said holes (4) consisting of a plurality of rows of longitudinally offset slotted holes.
2. A frame as claimed in claim 1, **characterised in that** said holes (4) are obtained by removal of material.
3. A frame as claimed in claim 1, **characterised in that** said holes (4) are obtained by expansion (cutting and stretching the material).

Patentansprüche

1. Rahmen für Metalltüren, bestehend aus einem einzelnen Teil (2) eines zu einer U-Form gebogenen Blechs mit an dem Mauerwerk befestigbaren Armen (6) und mit einer Basis (10), die parallel zu der Kante (14) des Mauerwerks (8) angeordnet ist, wobei die Basis (10) wenigstens eine Lippe (18) aufweist, die parallel zu der Basis angeordnet ist und der Kante (14) des Mauerwerks zugewandt ist, wobei die Lippe durch Umbiegen des Blechteils UND durch Verbinden zweier einander zugewandter Leisten (20,20') erhalten wird, wobei eine isolierende Dichtung (22) zwischen den Leisten positioniert ist, **dadurch gekennzeichnet, dass** wenigstens eine der Leisten (20,20') mehrere Löcher (4) aufweist, wobei die Löcher (4) aus mehreren Reihen von länglich versetzten geschlitzten Löchern bestehen. 5
10
15
20
2. Rahmen nach Anspruch 1, **dadurch gekennzeichnet, dass** die Löcher (4) durch Entfernung von Material enthalten werden. 25
3. Rahmen nach Anspruch 1, **dadurch gekennzeichnet, dass** die Löcher (4) durch Erweiterung (Schneiden und Strecken des Materials) erhalten werden. 30

Revendications

1. Cadre pour portes métalliques, lequel consiste en une pièce (2) de feuillard plié en U dont les bras (6) peuvent être fixés à la maçonnerie et dont la base (10) est disposée parallèle au bord (14) de la maçonnerie (8), ladite base (10) étant pourvue d'au moins un pli (18) parallèle à la base et tourné vers le bord (14) de la maçonnerie, ledit pli étant obtenu en repliant sur elle-même la pièce de feuillard et en couplant l'une à l'autre deux faces (20, 20') en vis-à-vis, un joint d'étanchéité (22) étant disposé entre lesdites faces, **caractérisé en ce qu'**au moins une des faces (20, 20') est pourvue d'une pluralité de trous (4), lesdits trous (4) consistant en une pluralité de rangées de fentes débouchantes disposées de manière longitudinalement alternée. 35
40
45
2. Cadre selon la revendication 1, **caractérisé en ce que** lesdits trous (4) sont obtenus par enlèvement de matière. 50
3. Cadre selon la revendication 1, **caractérisé en ce que** lesdits trous (4) sont obtenus par expansion (découpe et étirage du matériau). 55

FIG. 1

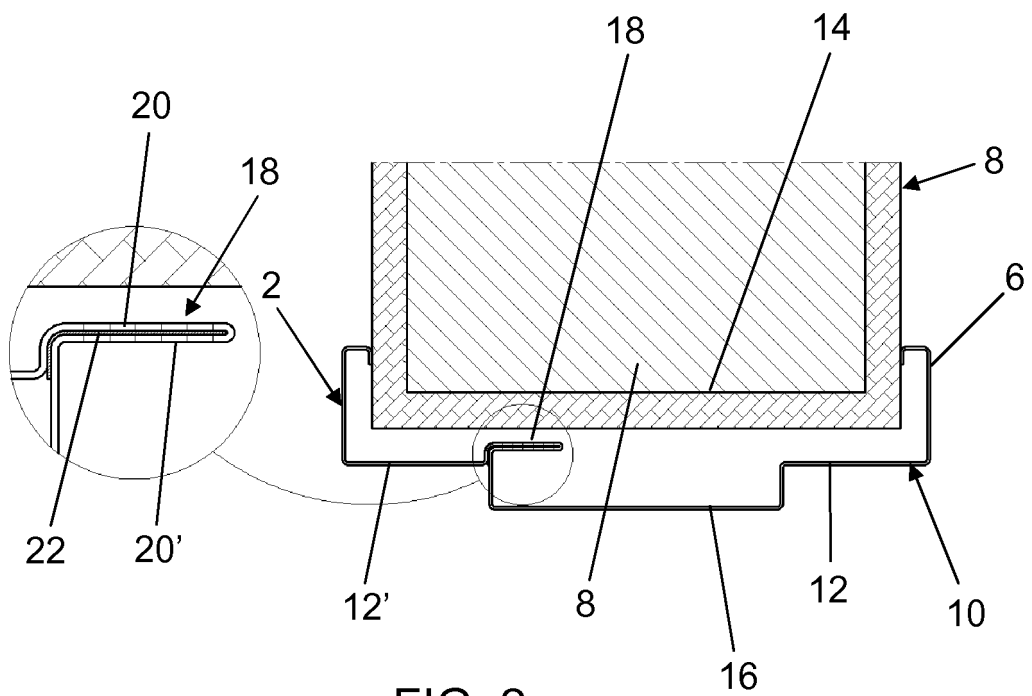
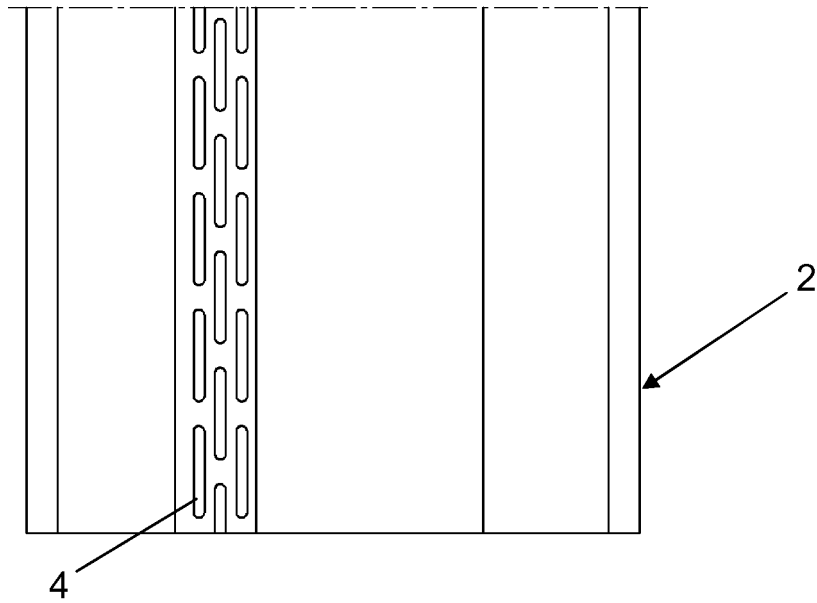

FIG. 2