



(11) **EP 2 884 038 B1**

(12) **EUROPEAN PATENT SPECIFICATION**

(45) Date of publication and mention of the grant of the patent:
06.09.2017 Bulletin 2017/36

(51) Int Cl.:
E06B 9/17 (2006.01)

(21) Application number: **14196572.3**

(22) Date of filing: **05.12.2014**

(54) **Housing for roll-up elements**

Gehäuse für aufrollbare Elemente

Logement pour des éléments à enroulement

(84) Designated Contracting States:
AL AT BE BG CH CY CZ DE DK EE ES FI FR GB GR HR HU IE IS IT LI LT LU LV MC MK MT NL NO PL PT RO RS SE SI SK SM TR

(30) Priority: **11.12.2013 IT PD20130337**

(43) Date of publication of application:
17.06.2015 Bulletin 2015/25

(73) Proprietor: **Alpac S.R.L. Unipersonale 36015 Schio (VI) (IT)**

(72) Inventor: **Bariletti, Filippo 36015 Schio VI (IT)**

(74) Representative: **Modiano, Micaela Nadia et al Modiano & Partners Via Meravigli, 16 20123 Milano (IT)**

(56) References cited:
EP-A1- 1 160 413 EP-A2- 0 183 953
DE-A1- 2 013 163 DE-A1- 2 913 698
DE-A1-102005 055 384 US-A- 4 399 855

EP 2 884 038 B1

Note: Within nine months of the publication of the mention of the grant of the European patent in the European Patent Bulletin, any person may give notice to the European Patent Office of opposition to that patent, in accordance with the Implementing Regulations. Notice of opposition shall not be deemed to have been filed until the opposition fee has been paid. (Art. 99(1) European Patent Convention).

Description

[0001] The present invention relates to a housing for roll-up elements.

[0002] Nowadays, structures for housing roll-up elements, such as roller blinds, shutters, awnings, shades or the like, generally comprise a box-like containment body, for example a housing, which is closed laterally by corresponding lateral covers and open in a downward region, in the configuration for use, for the insertion of winding shaft for a roll-up element; the lateral covers are fixed, with reversible locking means, each to a corresponding shoulder of a walled frame of a door or window with which such housing is associated.

[0003] At the ends of such winding shaft there are corresponding pins, which are designed to be coupled to respective supports fixed to the lateral covers of the housing.

[0004] Such system of installing a housing makes it possible to optimize the thermal and acoustic insulation with respect to outmoded boxes with front covers for inspection and mounting of the shaft.

[0005] Although widespread and appreciated, such conventional structures for housing roll-up elements suffer a number of drawbacks, which are linked to the systems for fixing the lateral cover to the shoulder of the walled frame.

[0006] The lateral covers, in fact, are often fixed by way of a lower flap thereof, to an L-shaped metallic bracket, by way of a plurality of threaded elements which are screwed substantially vertically and upwardly from below.

[0007] Such locking system has been found to be rather imprecise, and lacking from the viewpoint of thermal insulation, since the metallic bracket in any case constitutes a non-negligible thermal bridge.

[0008] Furthermore the screwing of the threaded elements upwardly from below and proximate to the outer surface of the shoulder on which the housing rests is typically an inconvenient operation.

[0009] Another system for fixing the lateral covers to the shoulder of the walled frame involves first mounting the covers, together with the housing, on a supporting frame, such supporting frame being designed to be locked to the two opposing shoulders of the walled frame by way of engagement means with bayonet coupling, such means involving the insertion of a first part onto a second part along a first direction, and subsequently sliding in a second direction, perpendicular to the first, with snap-acting locking intervening during such sliding.

[0010] Such bayonet coupling means with coupling by snap action are made with two special complex components made of plastic material, which still couple with a minimal amount of play that in any case results in the presence of a thermal bridge.

[0011] EP 0 183 953 A2 discloses an exterior roll-up shutter comprising two positioning strips positioned vertically against the outside of a wall at a window, and each

having a slit extending along it, in which a tongue of a respective assembly plate attached laterally to a shutter housing slidingly extends, with a pin on the free end of the tongue preventing the assembly plates from slipping out of the strip, and upon which the assembly plates may pivot. With the plates pivoted outwardly with respect to the strips, they may move vertically, together with the shutter housing, in the slits. When the shutter housing with lateral plates reach the top of the strips, the plates are pivoted inwardly until the housing rests on top of the positioning strips, whereupon the assembly plates are secured to the strips by driving screws through the strips and tongues in a lateral direction or by driving screws into the strips through a securing tab of the plates in a forward direction.

[0012] The aim of the present invention is to provide a housing for roll-up elements which is capable of overcoming the above mentioned drawbacks of the known art.

[0013] Within this aim, an object of the invention is to provide a housing for roll-up elements which enables a simple and rapid assembly of a lateral cover of a housing, or of a housing, or of a lintel, to the posts that define the shoulders of a walled frame.

[0014] A further object of the invention is to provide a housing that makes it possible to assemble the posts to the corresponding lateral cover of a housing, or to a housing, or to a lintel which in turn supports a housing, even for persons without special training.

[0015] Another object of the invention is to provide a housing that is capable of ensuring an improved thermal and acoustic insulation with respect to conventional housings.

[0016] Another object of the invention is to provide a housing whose couplings with the posts or shoulders of the walled frame to which it is fixed confer an overall rigidity to the system which is greater than that offered by the known art.

[0017] This aim and these and other objects which will become better evident hereinafter are achieved by a housing for roll-up elements according to claim 1. Further characteristics and advantages of the invention will become better apparent from the dependent claims and from the description of a preferred, but not exclusive, embodiment of the housing according to the invention, which is illustrated by way of non-limiting example in the accompanying drawings wherein:

- Figure 1 is a cutaway perspective view of a housing for roll-up elements according to the invention;
- Figure 2 is a side view of a housing according to the invention;
- Figure 3 is a sectional side view of a lateral cover of a housing according to the invention;
- Figure 4 is a sectional side view of the housing according to the invention;
- Figure 5 is a schematic view from above of the locking flap of a lateral cover;

- Figure 6 is a sectional view of the reversible locking means;
- Figure 7 is a sectional side view of a first variation of embodiment of the locking means;
- Figure 8 is a sectional side view of a second variation of embodiment of the locking means.

[0018] With reference to the figures, a housing for roll-up elements is generally designated with the reference numeral 10.

[0019] The housing 10 comprises a boxlike body 11 that is open in a lower region, in the configuration for use, and is closed laterally by two lateral covers 12 and 13 respectively.

[0020] The lateral covers 12 and 13 are fixed, with reversible locking means 14, each to a corresponding shoulder 15 and 16 of a walled frame of a door or window with which such housing 10 is associated.

[0021] One of the peculiarities of the housing 10 for roll-up elements according to the invention consists in that the reversible locking means 14 comprise:

- a first element 17 that is adapted to pass, along a first insertion direction 18, through a through opening 19 which is defined on a corresponding locking flap 20 of a lateral cover 12 and 13; the first element 17 is adapted to be arranged in a corresponding seat 21, clearly visible in Figures 5 and 6, on a locking portion 22 associated with one of the respective shoulders 15 and 16; the first element 17 has an extraction-preventing head 23 that is adapted to encounter the locking flap 20;
- a second element 24 that is adapted to be inserted in the locking portion 22 of the shoulder along a second insertion direction 28, which is transverse to the first direction 18, for the movement of the first element 17 so as to lock the locking flap 20 of a lateral cover 12 and 13 between the extraction-preventing head 23 and the locking portion 22 on the shoulder.

[0022] The first element 17, which is adapted to pass, along the first insertion direction 18, through the through opening 19 on the locking flap 20 of a lateral cover 12 and 13, comprises a substantially cylindrical body 25 from which the extraction-preventing head 23 widens at one end.

[0023] The cylindrical body 25 is inserted, again by way of translational movement in the first direction 18, into a corresponding complementarily shaped hole 26 defined on a locking insert 27, described in more detail hereinafter.

[0024] The cylindrical body 25 has a lateral recess 30, extending substantially in the second direction 28, which comprises an inclined surface 31 that is designed for contact with the pointed end 32 of the second element 24.

[0025] The lateral recess 30 has, for example, a conical or frustum-like or wedge-like profile.

[0026] The locking insert 27 in turn is designed to be

inserted, along the second direction 28, in a corresponding seat 29 provided on the locking portion 22.

[0027] The locking insert 27 comprises a substantially cylindrical body in which the hole 26 is provided in a radial direction, which coincides with the first direction 18 in the configuration for use, while in the axial direction, which coincides with the second direction 28 in the configuration for use, a threaded hole 33 is defined into which the second element 24 is adapted to be screwed.

[0028] The first element 17 has an abutment shoulder 34 that widens radially from the cylindrical body 25 for the abutment of an elastic pusher, for example, but not exclusively, a helical pusher spring 35, arranged so as to surround the cylindrical body 25 between the outer surface of the locking insert 27 and the abutment shoulder 34.

[0029] The second element 24, adapted to be inserted into the locking portion 22 of the shoulder along the second insertion direction 28 which is transverse to the first direction 18, is constituted for example by a threaded grub screw with a substantially pointed end 32, referred to previously.

[0030] The through opening 19, which is defined on the corresponding locking flap 20 of a lateral cover 12 and 13, has a first part 38 whose dimensions are such as to allow the passage of the extraction-preventing head 23, and a contiguous second part 39 whose transverse width is smaller than the corresponding dimension of the extraction-preventing head 23.

[0031] In the example described, but not exclusively, the through opening 19 has two symmetrical first parts 38 and 40 with respect to the second part 39 which is interposed between these two first parts.

[0032] The locking portion 22, which is designed to be associated with a respective shoulder 15 and 16, is constituted by a contoured block, made of plastic material or metallic material or wooden material, which is provided with one or more first seats 21 for a corresponding number of first elements 17 and respective second seats 29 for the second elements 24.

[0033] Operation of the reversible locking means 14 is the following.

[0034] Once the locking portion 22 is fixed to the shoulder 15, or 16, of the walled frame, first the locking insert 27 is inserted into its seat 29 along the second direction 28, oriented so that its radial hole 26 is aligned with the first insertion direction 18 for the first element 17.

[0035] Then the helical spring 35 is inserted into the seat 21, so that such spring rests on the outer surface of the locking insert 27, and then the first element 17 is inserted, again in the first direction 18, and is thus maintained in the open configuration by the helical spring 35.

[0036] In such configuration of the locking means 14 being open, the lateral recess 30 is only partially facing toward the threaded hole 33 for the second element 24, but at a height that is such that the inclined surface 31 of the lateral recess 30 can be engaged by the tip 32 of the threaded grub screw that defines the second element

24.

[0037] In such configuration, the locking means 14 are adapted for coupling with the locking flap 20 of the lateral cover 12 or 13; the extraction-preventing head 23 of the first element 17 is passed through one of the first parts 38 or 40 of a through opening 19 on the locking flap 20, and subsequently the corresponding cover 12 or 13, of which the flap 20 is part, performs a translational motion so that the extraction-preventing head 23 is arranged at the second part 39 of the opening 19, a position in which the flap 20 can be locked between the extraction-preventing head 23 and the underlying locking portion 22.

[0038] Subsequently, the second element 24 is screwed into the corresponding threaded hole 33, until the tip 32 encounters the inclined surface 31 of the lateral recess 30 of the first element 17.

[0039] By screwing the threaded grub screw, i.e. the second element 24, the latter advances against the lateral recess 30, and by pushing on the inclined surface 31 it causes the translational movement of the first element 17 downwardly, thanks to a sort of 'wedge effect'.

[0040] Figure 6 clearly shows the locking means 14 in the open configuration, in dotted lines, and in the closed configuration, with the tip 32 of the second element 24 completely engaged in the lateral recess 30 of the first element 17.

[0041] In such locked configuration, the locking flap 20 is closed between the locking portion 22 and the extraction-preventing head 23.

[0042] By unscrewing the second element 24, the helical spring 35 pushes the first element 17 upwardly, causing the automatic release of the flap 20.

[0043] In a first variation of embodiment of the locking means according to the invention, shown for the purposes of example in Figure 7 and designated therein with the reference numeral 114, the locking means comprise:

- a first element 117, which is adapted to pass, along the first insertion direction 118, through the through opening 119 on the locking flap 120 of a lateral cover, which comprises a substantially cylindrical body 125 from which widens, at one end, the extraction-preventing head 123.
- a second element 124, which is adapted to be inserted into the locking portion 122 of the shoulder along a second insertion direction 128, which is transverse to the first direction 118, for the movement of the first element 117 so as to lock the locking flap 120 of the lateral cover between the extraction-preventing head 123 and the locking portion 122, with such second element 124, i.e. a threaded grub screw, being screwed directly into a corresponding hole 133 that is defined on the locking portion 122, without the interposition of a locking insert as in the embodiment described above.

[0044] In such first variation of embodiment, the helical pusher spring 135 is interposed so as to work between

the bottom of the seat 121 of the first element 117 and the end 150 of the first element 117.

[0045] In a second variation of embodiment of the locking means according to the invention, shown for the purposes of example in Figure 8 and designated therein with the reference numeral 214, the locking means comprise:

- a first element 217 that is adapted to pass, along a first insertion direction 218, through a through opening 219 which is defined on a corresponding locking flap 220 of a lateral cover, with such first element 217 being adapted to be arranged in a corresponding seat 221 that is defined directly on the shoulder 215 of a walled frame of a door or window, instead of on an adapted locking portion 22 associated with the respective shoulder as described above for previous embodiments; the first element 217 has an extraction-preventing head 223 that is adapted to encounter the locking flap 220;
- a second element 224 that is adapted to be inserted into the shoulder 215, along a second insertion direction 228 which is transverse to the first direction 218, directly into a corresponding threaded hole 233 that is defined on the shoulder 215, and not into a locking portion 22.

[0046] Thus in the presence of a shoulder of a material that is of adequate strength, the locking means 214 are simplified further by providing the seat 221 and the threaded hole 233 directly on the high part of the shoulder 215, thus in fact eliminating two components, i.e. the locking portion 22 and the locking insert 27.

[0047] In the present embodiment, the locking means 214 comprise the first 217 and second elements 224 only, as well as the elastic pusher, while working in the same way.

[0048] In practice it has been found that the invention fully achieves the intended aim and objects.

[0049] In particular, with the invention a housing for roll-up elements has been devised which enables a simple and rapid assembly of a lateral cover of a housing, or of a housing, or of a lintel, to the posts that define the shoulders of a walled frame.

[0050] In particular, with the invention a housing has been devised that makes it possible to assemble the posts to the corresponding lateral cover of a housing, or to a housing, or to a lintel which in turn supports a housing, even for persons without special training, a screwdriver or screw gun being necessary and sufficient in order to screw the second element 24.

[0051] Moreover, with the invention a housing has been provided that is capable of ensuring an improved thermal and acoustic insulation with respect to conventional housings, thanks to the certainty and precision of the locking determined by screwing the second element 24 on one side and by the consequent locking of the flap 20 of the lateral cover 12 and 13 between the locking portion 22 and the extraction-preventing head of the first

element 17, such locking eliminating thermal bridges and geometric inaccuracies of the fixing.

[0052] Furthermore, thanks to the housing according to the invention, the locking means 14 confer an overall rigidity on the system which is greater than that offered by the known art, by eliminating play between the covers and the shoulders.

[0053] The invention, thus conceived, is susceptible of numerous modifications and variations, all of which are within the scope of the appended claims. Moreover, all the details may be substituted by other, technically equivalent elements.

[0054] In practice the materials employed, provided they are compatible with the specific use, and the contingent dimensions and shapes, may be any according to requirements and to the state of the art.

[0055] Where technical features mentioned in any claim are followed by reference signs, such reference signs have been inserted for the sole purpose of increasing the intelligibility of the claims and accordingly such reference signs do not have any limiting effect on the interpretation of each element identified by way of example by such reference signs.

Claims

1. A housing (10) for roll-up elements, which comprises a box-like body (11) that is open in a lower region, in the configuration for use, and is closed laterally by two lateral covers (12, 13), said covers being fixed, with reversible locking means (14), each to a corresponding shoulder (15, 16) of a walled frame of a door or window with which said housing is associated, said reversible locking means (14) comprising:

- a first element (17) that is adapted to pass, along a first insertion direction (18), through a through opening (19) on a corresponding locking flap (20) of a said lateral cover (12, 13) and is adapted to be arranged in a corresponding seat (21) on a locking portion (22) associated with one of said shoulders (15, 16), with an extraction-preventing head (23) adapted to encounter said locking flap (20),

- a second element (24) that is adapted to be inserted in said locking portion (22) of said shoulder along a second insertion direction (28), which is transverse to said first direction (18), for the movement of said first element (17) so as to lock said locking flap (20) of a said lateral cover (12, 13) between said extraction-preventing head (23) and said locking portion (22) on said shoulder, said first element (17) comprising a substantially cylindrical body (25) from which said extraction-preventing head (23) widens at one end, characterized in that said cylindrical

body (25) has a lateral recess (30) that comprises an inclined surface (31) that is designed for contact with the pointed end (32) of the second element (24), said lateral recess (30) has for example a conical or frustum-like or wedge-like profile, and said second element (24) is constituted by a threaded grub screw with a substantially pointed end (32).

2. The housing according to claim 1, **characterized in that** said cylindrical body (25) is inserted, by way of translational movement in the first direction (18), in a corresponding complementarily shaped hole (26) defined on a locking insert (27).
3. The housing according to claim 2, **characterized in that** said locking insert (27) in turn is designed to be inserted, along the second direction (28), in a corresponding seat (29) provided on said locking portion (22).
4. The housing according to claim 2, **characterized in that** said locking insert (27) comprises a substantially cylindrical body in which said hole (26) is provided in a radial direction, which coincides with the first direction (18) in the configuration for use, while in the axial direction, which coincides with the second direction (28) in the configuration for use, there is a threaded hole (33) into which the second element (24) is adapted to be screwed.
5. The housing according to the preceding claims, **characterized in that** said first element (17) has an abutment shoulder (34) that widens radially from the cylindrical body (25) for the abutment of an elastic pusher, for example a helical spring (35), arranged between the outer surface of the locking insert (27) and said abutment shoulder (34).
6. The housing according to the preceding claims, **characterized in that** said through opening (19), defined on the corresponding locking flap (20) of a lateral cover (12, 13), has a first part (38) whose dimensions are such as to allow the passage of the extraction-preventing head (23) and a contiguous second part (39) whose transverse width is smaller than the corresponding dimension of the extraction-preventing head (23).
7. The housing according to the preceding claims, **characterized in that** said locking portion (22), designed to be associated with a respective shoulder (15, 16), is constituted by a contoured block, made of plastic material or metallic material or wooden material, which is provided with one or more first seats (21) for a corresponding number of first elements (17) and respective second seats (29) for the respective second elements (24).

Patentansprüche

1. Ein Gehäuse (10) für aufrollbare Elemente, das einen kastenartigen Körper (11) umfasst, der in der Gebrauchsanordnung in einem unteren Bereich offen ist und der seitlich durch zwei Seitenabdeckungen (12, 13) verschlossen ist, wobei die Abdeckungen durch lösbare Blockiermittel (14) jeweils an einer entsprechenden Schulter (15, 16) eines ummauerten Rahmens einer Tür oder eines Fensters, mit der/dem das Gehäuse verbunden ist, befestigt sind, wobei die lösbaren Blockiermittel (14) Folgendes umfassen:

- ein erstes Element (17), das ausgebildet ist, um entlang einer ersten Einführrichtung (18) eine Durchgangsöffnung (19) in einer entsprechenden Blockierklappe (20) der Seitenabdeckung (12, 13) zu durchdringen; und das ausgebildet ist, um in einem entsprechenden Sitz (21) an einem Blockierabschnitt (22) angeordnet zu werden, der mit einer der Schultern (15, 16) verbunden ist, mit einem die Extraktion verhindernden Kopf (23), der ausgebildet ist, um die Blockierklappe (20) zu treffen,

- ein zweites Element (24), das ausgebildet ist, um entlang einer zweiten Einführrichtung (28) in den Blockierabschnitt (22) der Schulter eingeführt zu werden, die quer zu der ersten Richtung (18) ist, zum Zwecke der Bewegung des ersten Elements (17), um die Blockierklappe (20) der Seitenabdeckung (12, 13) zwischen dem die Extraktion verhindernden Kopf (23) und dem Blockierabschnitt (22) an der Schulter zu blockieren, wobei das erste Element (17) einen im Wesentlichen zylindrischen Körper (25) umfasst, aus dem sich der die Extraktion verhindernde Kopf (23) an einem Ende erweitert, **dadurch gekennzeichnet, dass** der zylindrische Körper (25) eine seitliche Vertiefung (30) hat, welche eine schräge Oberfläche (31) umfasst, die dem Kontakt mit dem spitzen Ende (32) des zweiten Elements (24) dient, wobei die seitliche Vertiefung (30) zum Beispiel ein kegelförmiges oder kegelstumpfförmiges oder keilförmiges Profil hat und das zweite Element (24) in einem Gewindestift mit einem im Wesentlichen spitzen Ende (32) besteht.

2. Das Gehäuse gemäß Anspruch 1, **dadurch gekennzeichnet, dass** der zylindrische Körper (25) durch eine Translationsbewegung in die erste Richtung (18) in eine entsprechende komplementär geformte Öffnung (26) eingesetzt wird, die in einem Blockiereinsatz (27) bestimmt ist.

3. Das Gehäuse gemäß Anspruch 2, **dadurch gekennzeichnet, dass** der Blockiereinsatz (27) wie-

derum konstruiert ist, um entlang der zweiten Richtung (28) in einen entsprechenden Sitz (29) eingesetzt zu werden, der an dem Blockierabschnitt (22) angebracht ist.

4. Das Gehäuse gemäß Anspruch 2, **dadurch gekennzeichnet, dass** der Blockiereinsatz (27) einen im Wesentlichen zylindrischen Körper umfasst, in dem die Bohrung (26) in einer radialen Richtung angebracht ist, die in der Gebrauchsanordnung mit der ersten Richtung (18) zusammenfällt, während sich in der axialen Richtung, die in der Gebrauchsanordnung mit der zweiten Richtung (28) zusammenfällt, eine Gewindebohrung (33) befindet, in die eingeschraubt zu werden das zweite Element (24) ausgebildet ist.

5. Das Gehäuse gemäß den obigen Ansprüchen, **dadurch gekennzeichnet, dass** das erste Element (17) eine Anschlagschulter (34) hat, die sich zum Anstoßen einer elastischen Schubvorrichtung, zum Beispiel einer Schraubenfeder (35), angeordnet zwischen der äußeren Oberfläche des Blockiereinsatzes (27) und der Anschlagschulter (34), radial vom zylindrischen Körper (25) erweitert.

6. Das Gehäuse gemäß den obigen Ansprüchen, **dadurch gekennzeichnet, dass** die Durchgangsöffnung (19), bestimmt in der entsprechenden Blockierklappe (20) einer Seitenabdeckung (12, 13), einen ersten Teil (38) hat, dessen Maße geeignet sind, den Durchtritt des die Extraktion verhindernden Kopfes (23) zu ermöglichen, und einen benachbarten zweiten Teil (39), dessen transversale Breite kleiner ist als die entsprechende Abmessung des die Extraktion verhindernden Kopfs (23).

7. Das Gehäuse gemäß den obigen Ansprüchen, **dadurch gekennzeichnet, dass** der Blockierabschnitt (22), konstruiert, um mit einer entsprechenden Schulter (15, 16) gekoppelt zu werden, aus einem konturierten Block besteht, der aus Kunststoffmaterial oder Metallmaterial oder Holzmaterial hergestellt ist, der mit einem oder mehreren ersten Sitzen (21) für eine entsprechende Anzahl erster Elemente (17) und entsprechenden zweiten Sitzen (29) für die entsprechenden zweiten Elemente (24) versehen ist.

Revendications

1. Boîtier (10) pour éléments à enroulement, comprenant un corps en forme de boîte (11) qui est ouvert dans une région inférieure, dans la configuration d'utilisation, et qui est fermé latéralement par deux couvercles latéraux (12, 13), lesdits couvercles étant fixes, avec des moyens de blocage réversibles (14), chacun sur un épaulement correspondant (15, 16)

d'un châssis à parois d'une porte ou fenêtre à laquelle ledit boîtier est associé, lesdits moyens de blocage réversibles (14) comprenant :

- un premier élément (17) qui est adapté pour passer, le long d'une première direction d'insertion (18), par une ouverture traversante (19) présente sur un rebord de blocage correspondant (20) de l'un desdits couvercles latéraux (12, 13) et qui est adapté pour être placé dans un siège correspondant (21) présent sur une partie de blocage (22) associée à l'un desdits épaulements (15, 16), avec une tête empêchant l'extraction (23) adaptée pour entrer en contact avec ledit rebord de blocage (20),
 - un deuxième élément (24) qui est adapté pour être inséré dans ladite partie de blocage (22) dudit épaulement le long d'une deuxième direction d'insertion (28), qui est transversale à ladite première direction (18), pour le mouvement dudit premier élément (17) afin de bloquer ledit rebord de blocage (20) de l'un desdits couvercles latéraux (12, 13) entre ladite tête empêchant l'extraction (23) et ladite partie de blocage (22) sur ledit épaulement, ledit premier élément (17) comprenant un corps substantiellement cylindrique (25) à partir duquel ladite tête empêchant l'extraction (23) s'élargit à une extrémité, **caractérisé en ce que** ledit corps cylindrique (25) comporte un évidement latéral (30) qui comprend une surface inclinée (31) qui est conçue pour le contact avec l'extrémité pointue (32) du deuxième élément (24), ledit évidement latéral (30) a par exemple un profil conique, tronconique ou en coin, et ledit deuxième élément (24) est constitué par une vis sans tête ayant une extrémité substantiellement pointue (32).
2. Boîtier selon la revendication 1, **caractérisé en ce que** ledit corps cylindrique (25) est inséré, par un mouvement de translation dans la première direction (18), dans un trou correspondant de forme complémentaire (26) défini sur un insert de blocage (27).
 3. Boîtier selon la revendication 2, **caractérisé en ce que** ledit insert de blocage (27) est lui-même conçu pour être inséré, le long de la deuxième direction (28), dans un siège correspondant (29) prévu sur ladite partie de blocage (22).
 4. Boîtier selon la revendication 2, **caractérisé en ce que** ledit insert de blocage (27) comprend un corps substantiellement cylindrique dans lequel ledit trou (26) est placé dans une direction radiale, qui coïncide avec la première direction (18) dans la configuration d'utilisation, tandis que dans la direction axiale, qui coïncide avec la deuxième direction (28) dans la configuration d'utilisation, se trouve un trou fileté

(33) dans lequel le deuxième élément (24) peut être vissé.

5. Boîtier selon les revendications précédentes, **caractérisé en ce que** ledit premier élément (17) comporte un épaulement d'appui (34) qui s'élargit radialement depuis le corps cylindrique (25) pour permettre l'appui d'un poussoir élastique, par exemple un ressort hélicoïdal (35), placé entre la surface extérieure de l'insert de blocage (27) et ledit épaulement d'appui (34).
6. Boîtier selon les revendications précédentes, **caractérisé en ce que** ladite ouverture traversante (19), définie sur le rebord de blocage correspondant (20) d'un couvercle latéral (12, 13), comporte une première partie (38) dont les dimensions sont telles qu'elle permet le passage de la tête empêchant l'extraction (23) et une deuxième partie contiguë (39) dont la largeur transversale est inférieure à la dimension correspondante de la tête empêchant l'extraction (23).
7. Boîtier selon les revendications précédentes, **caractérisé en ce que** ladite partie de blocage (22), conçue pour être associée à un épaulement respectif (15, 16), est constituée d'un bloc profilé, fait d'une matière plastique ou d'une matière métallique ou de bois, qui est pourvu d'un ou de plusieurs sièges (21) pour un nombre correspondant de premiers éléments (17) et de deuxièmes sièges respectifs (29) pour les deuxièmes éléments respectifs (24).

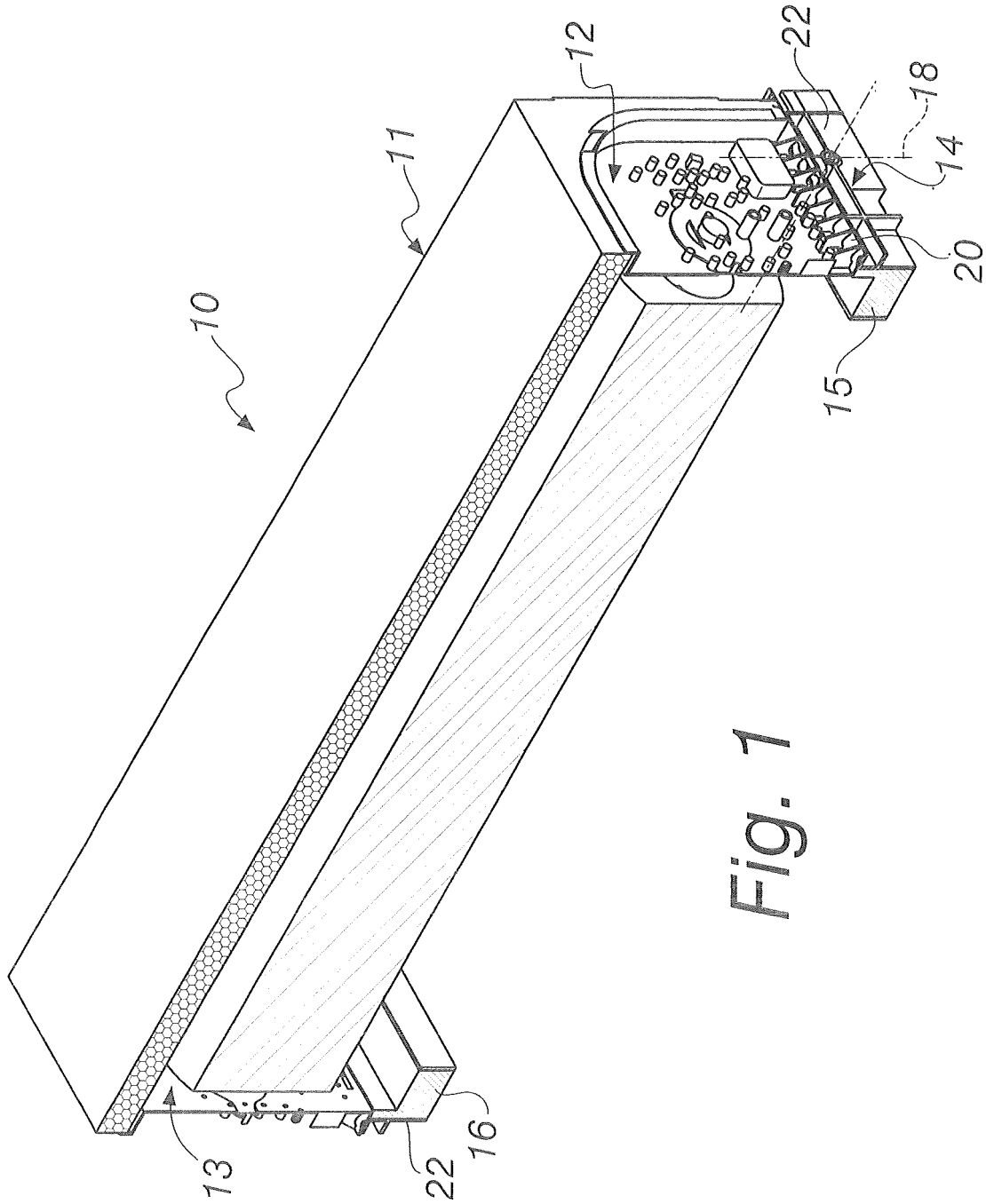

Fig. 1

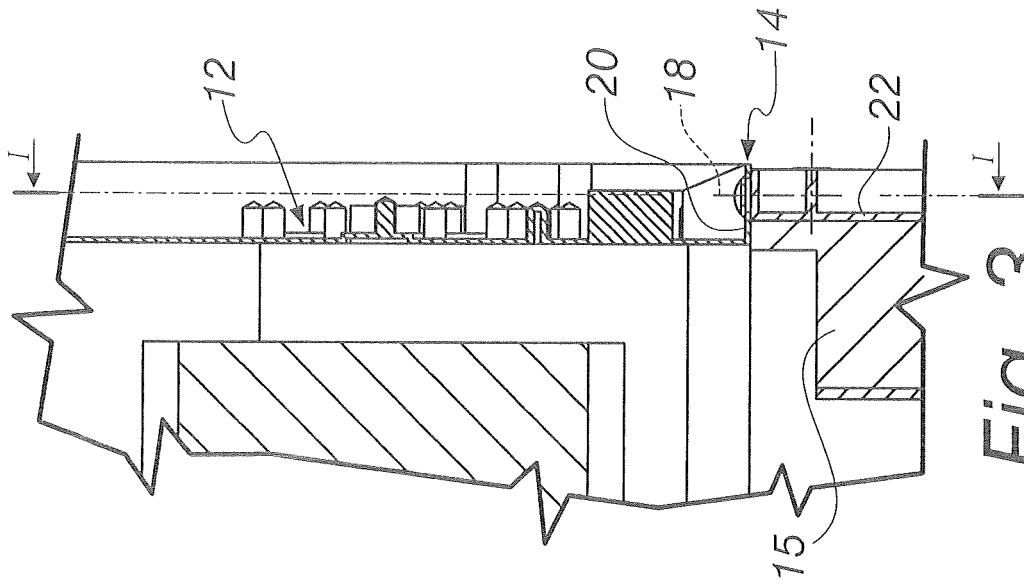

Fig. 3

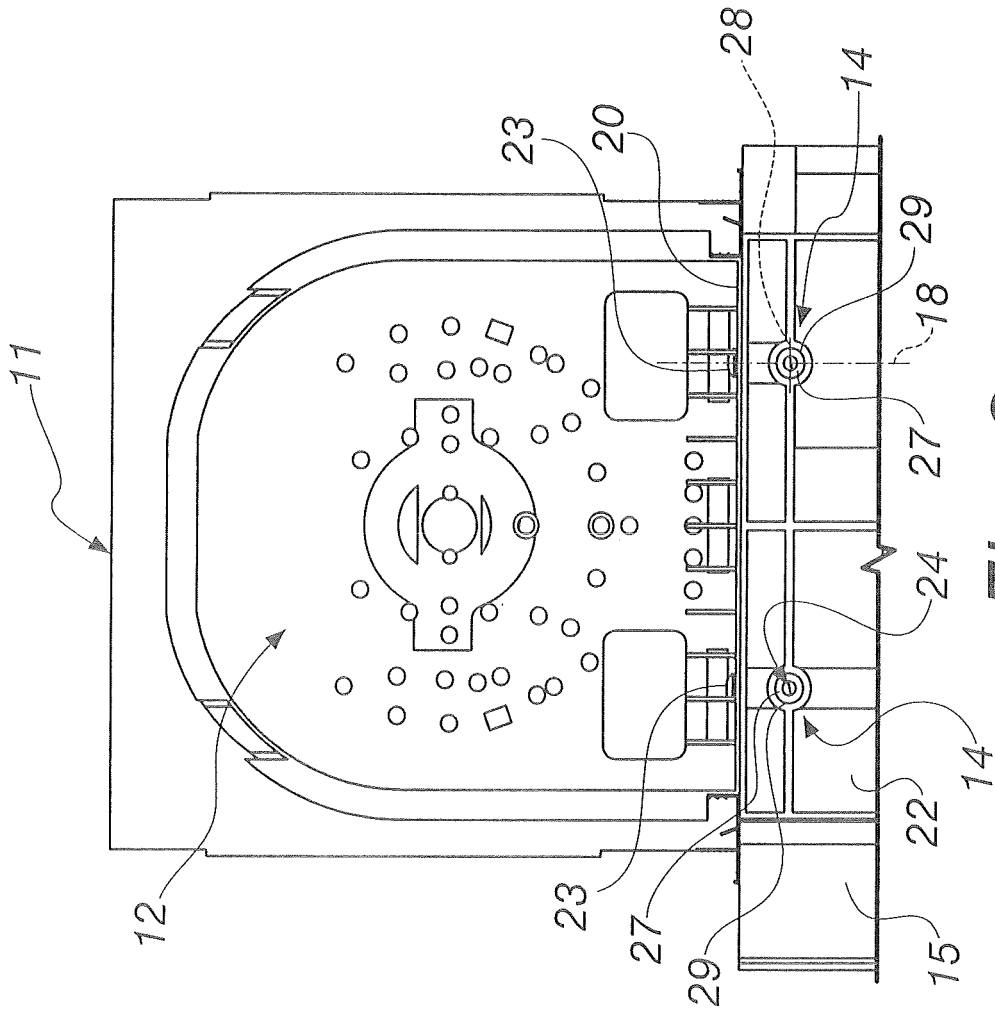

Fig. 2

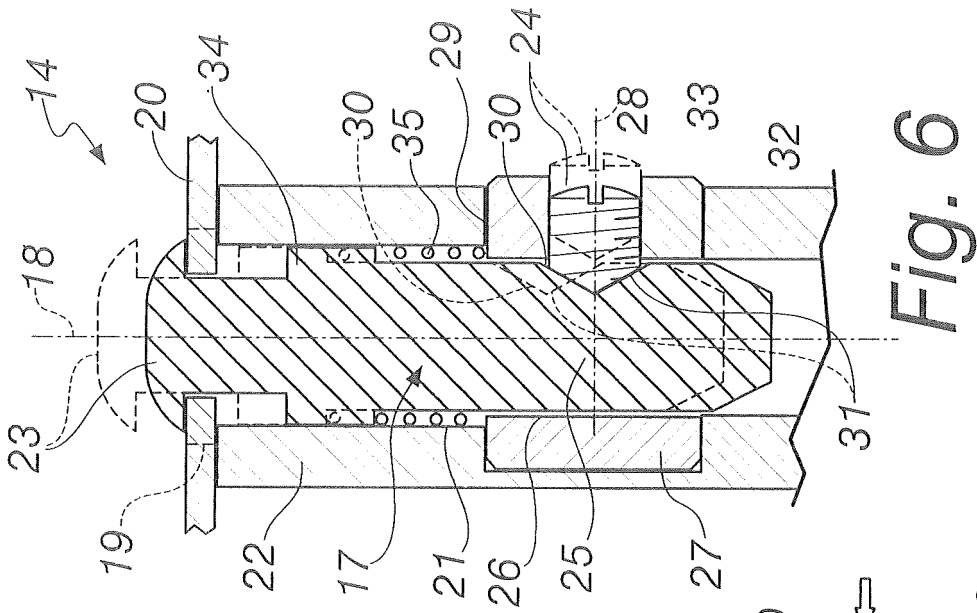

Fig. 6

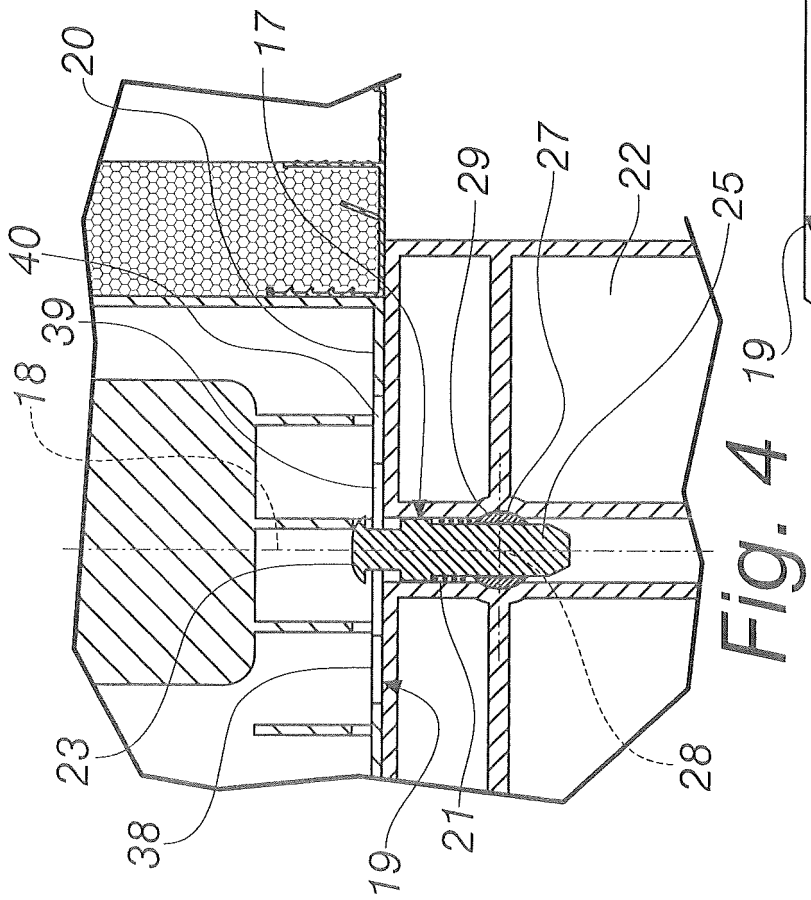

Fig. 4

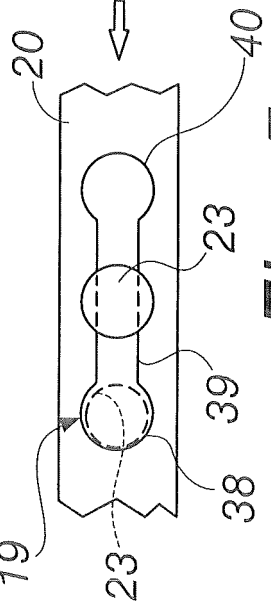

Fig. 5

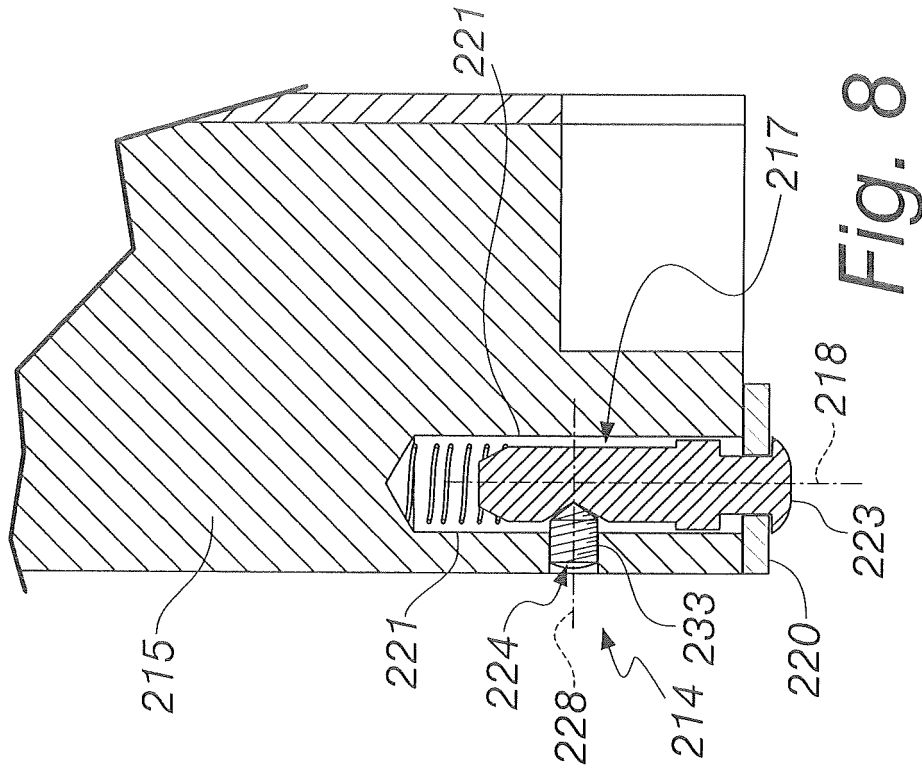

Fig. 8

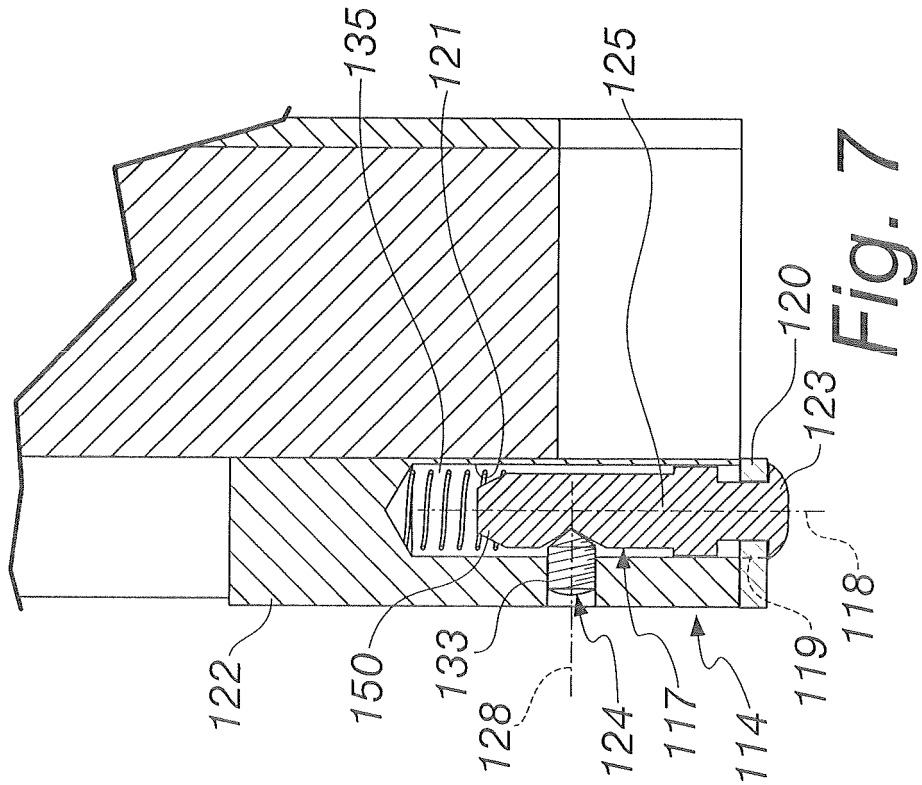

Fig. 7

REFERENCES CITED IN THE DESCRIPTION

This list of references cited by the applicant is for the reader's convenience only. It does not form part of the European patent document. Even though great care has been taken in compiling the references, errors or omissions cannot be excluded and the EPO disclaims all liability in this regard.

Patent documents cited in the description

- EP 0183953 A2 [0011]