



(11)

**EP 2 894 392 A1**

(12)

**EUROPEAN PATENT APPLICATION**

(43) Date of publication:  
**15.07.2015 Bulletin 2015/29**

(51) Int Cl.:  
**F21S 8/08<sup>(2006.01)</sup> F21V 7/09<sup>(2006.01)</sup>**

(21) Application number: **14368005.6**

(22) Date of filing: **10.01.2014**

(84) Designated Contracting States:  
**AL AT BE BG CH CY CZ DE DK EE ES FI FR GB GR HR HU IE IS IT LI LT LU LV MC MK MT NL NO PL PT RO RS SE SI SK SM TR**  
Designated Extension States:  
**BA ME**

(72) Inventors:  
• **Rocard, Florian**  
**95800 Cergy Le Haut (FR)**  
• **Mulin, Alice**  
**25170 Noironte (FR)**

(71) Applicant: **Thorn Europhane S.A.**  
**27705 Les Andelys Cedex (FR)**

(74) Representative: **Kiwit, Benedikt**  
**Mitscherlich PartmbB**  
**Patent- und Rechtsanwälte**  
**Sonnenstraße 33**  
**80331 München (DE)**

(54) **Lighting device for illumination streets, roads or paths**

(57) Lighting device (100) for illuminating streets, roads or paths, comprising: at least one light source (220) comprising at least one light emitting diode; at least one reflector (120) comprising an essentially saddle-shaped reflection surface (150); wherein the light source (220) is arranged such that at least a part of the emitted light

is directed to the reflection surface (150) of the reflector (120); and wherein the light is reflected by the reflection surface (150) in such a way that a wide light distribution of the lighting device (100) is provided at least in a direction parallel to a surface to be illuminated and perpendicular to a main axis (160) of the reflection surface (150).

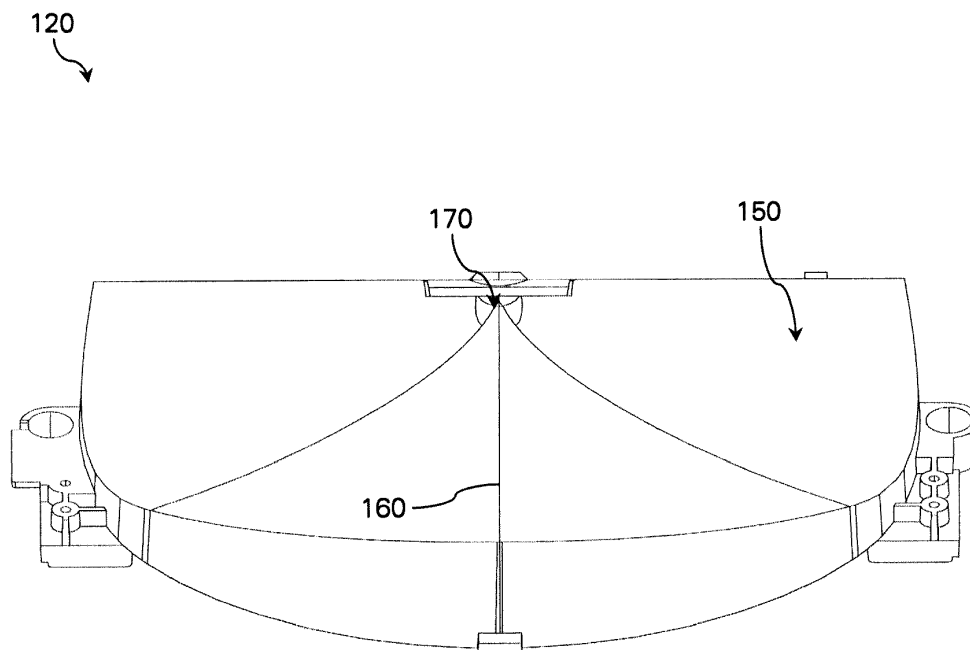

**Fig. 2**

**EP 2 894 392 A1**

## Description

### 1. Field of the invention

[0001] The present invention relates to a lighting device for illuminating streets, roads or paths, as well as to a corresponding lighting system for illuminating streets, roads or paths.

### 2. Technical background

[0002] From the prior art, lighting devices for illuminating streets or roads are well-known. For example, document WO 2006/092538 A1 discloses a device for illuminating traffic lanes having a light source arranged at a vertical height of not more than 1 m. In this document, it is further disclosed that the lighting device is mounted on a guard rail (e.g. on a guard rail placed in the middle of a highway) such that the device is preferably arranged under the position of a driver. However, in practice it has been found that a driver can be dazzled by the light of such a lighting device. Moreover, in this document, it is disclosed to use a gas-discharge lamp (HID lamp) due to the required luminance. However, in this respect, it has also to be noted that there are only limited design opportunities for the lighting device (*i.e.* for any reflector arrangement positioned adjacent to the light source) using such gas-discharge lamps due to the usual large dimensions of such gas-discharge lamps. As a result, there are also only limited opportunities for any reflector arrangement used in connection with such a gas-discharge lamp.

[0003] Therefore, it is an object of the present invention to provide a new lighting device for illuminating streets, roads or paths with which a wide distribution of the light emitted by the lighting device is reached, and whereby the risk to dazzle a driver by means of a lateral light is further minimized. These and other objects, which become apparent upon reading the following description, are solved by the subject-matter of the independent claims. The dependent claims refer to preferred embodiments of the invention.

### 3. Summary of the invention

[0004] According to the invention, a lighting device for illuminating streets, roads or paths is provided comprising: at least one light source comprising at least one light emitting diode; at least one reflector comprising an essentially saddle-shaped reflection surface, wherein the light source is arranged in such a way that at least a part of the light emitted by the light source is directed to the reflection surface of the reflector; and wherein the light is reflected by the reflection surface in such a way that a wide light distribution of the lighting device is provided at least in a direction parallel to a surface to be illuminated and perpendicular to a main axis of the reflection surface.

[0005] The lighting device according to the invention

is preferably mounted at a height of less than two meters, e.g. the present lighting device is preferably provided below the common position of a driver sitting in a vehicle.

[0006] The term saddle-shaped has to be understood as any structure having a mainly rounded shape with an elevated area and two laterally arranged indentations (*i.e.* two minima in the reflection surface) extending therefrom, thereby providing a surface/structure commonly known from a saddle.

[0007] By means of an arrangement comprising the above-mentioned at least one light source, which is preferably arranged/mounted at a central area with respect to the reflection surface, and the above-mentioned specifically shaped reflector a wide light distribution (*i.e.* a relatively broad light distribution) in a direction parallel to the surface to be illuminated and perpendicular to a main axis of the reflection surface (*e.g.* a symmetry line of the saddle-shaped reflection surface) can be provided.

[0008] Contrary to the known lighting devices using a gas-discharge lamp, the presently used light source can be provided as a relatively compact structure such that there are essentially no design limitations allowing using a specifically adapted reflector (*i.e.* a specifically adapted and arranged reflection surface). Thereby, the light emitted by the lighting device can be adjusted in such a way that the risk for dazzling a driver can be minimized. In other words, in particular by means of the saddle-shaped reflection surface a distribution of the light can be exactly adjusted as required by the respective mounting/application conditions.

[0009] Preferably, the reflection surface is mirror symmetrical with respect to the main axis of the reflection surface. Thereby, an essentially homogenous distribution of the light emitted by the lighting device can be provided in a direction parallel to the surface to be illuminated.

[0010] It is preferred that in top view, the reflection surface has a shape corresponding to a sector of a circle, preferably having an interior angle between 90° and 220° DEG, more preferably between 150° and 200° DEG, and even more preferably between 170° and 190° DEG. It is further preferred that in top view, the main axis of the reflection surface (*i.e.* the center of the elevated area) halves the reflection surface.

[0011] It is further preferred that at least two indentations/minima of the reflection surface are provided at an angle between +/- 50° and +/- 90° DEG, preferably between +/- 60° and +/- 85° DEG, and more preferably between +/- 70° and +/- 80° DEG with respect to the main axis of the reflection surface. By the positions of the minima (*i.e.* the indentations), the maximum width (*i.e.* the maximum angle) of the light distribution in a direction parallel to a surface to be illuminated and perpendicular to the main axis of the reflection surface is provided.

[0012] It is further preferred that the reflection surface does not comprise any jump discontinuities. Thereby, it is possible to provide a relatively homogenous light distribution, since thereby no overlap of the emitted light

occurs.

**[0013]** Preferably, in top view, the light is distributed with an angle greater than  $\pm 50^\circ$  DEG preferably greater than  $\pm 70^\circ$  DEG, and more preferably greater than  $\pm 75^\circ$  DEG with respect to the main axis of the reflection surface. In other words, the light is essentially distributed over the entire shape of the reflection surface (*i.e.* over the entire sector of a circle).

**[0014]** Preferably, perpendicular to the surface to be illuminated, the light is distributed with an angle greater than  $60^\circ$  DEG preferably greater than  $70^\circ$  DEG, and more preferably greater than  $80^\circ$  DEG, and most preferably the light is distributed with an angle of about  $85^\circ$  DEG; preferably measured at most from a horizontal plane downwards. Thereby, not only a wide light distribution of the lighting device in a direction parallel to a surface to be illuminated and perpendicular to the main axis of the reflection surface can be provided, but also a wide light distribution perpendicular to the surface to be illuminated can be provided.

**[0015]** It is further preferred that adjacent to the reflector at least one baffle is arranged, wherein the at least one baffle preferably comprises an inward reflection surface for redirecting light to the reflection surface of the reflector. In order to further ensure that no light is emitted dazzling a driver of a vehicle, a respective baffle can be arranged ensuring that no light is emitted parallel to the horizontal. Therefore, the baffle is preferably arranged such that it at least partially surrounds the light source (*i.e.* opposite to the reflection surface with respect to the light source). By means of the inward reflection surface, the respective part of the emitted light is redirected to the reflection surface, thereby further usable for an illumination. Notably, depending on the respective application, further baffles can be used for adjusting the shape and dimension of the emitted light.

**[0016]** Preferably, the lighting device comprises a housing in which the reflector and the at least one light source are housed. Preferably, the reflection surface is arranged (preferably downwards) inclined (*e.g.* in the housing) with its main axis with respect to the horizontal plane, preferably with an angle between  $20^\circ$  and  $60^\circ$  DEG, more preferably between  $30^\circ$  and  $50^\circ$  DEG and most preferably between  $35^\circ$  and  $45^\circ$  DEG. Notably, many experiments have been carried out in order to establish that the above-mentioned light distribution ranges can be provided using a saddle-shaped reflection surface which is arranged inclined with respect to the horizontal line, wherein a respective angle is dependent from the mounting height of the lighting device and from the respective surface to be illuminated.

**[0017]** Further, it is preferred that the light source is a directional light source emitting light essentially only in the direction to the reflection surface of the reflector. Thereby, light losses can be minimized and also any dazzling can be further avoided.

**[0018]** Preferably, the at least one light source is ar-

ranged above the main axis of the reflection surface, preferably in the center of the sector of a circle. The light source, preferably comprises a high brightness light emitting diode, a light emitting diode, a ray/cluster and/or a chip on board light emitting diode arrangement. By such an arrangement of the light source above the main axis, the light emitted by the light source is splitted and widened by means of the reflection surface, wherein about a half of the emitted light is directed to each symmetry part of the reflection surface. However, it can be further preferred that the lighting device comprises at least two light sources arranged with an offset with respect to the main axis of the reflection surface such that each light source emits light to a half of the mirror symmetrical shaped reflection surface. Thereby, it is possible to assign respective light sources to a specific part of the reflection surface, wherein thereby an essentially homogenous distribution of the emitted light is still provided. Such an arrangement also provides the possibility to increase the light quantity emitted by a lighting device.

**[0019]** The present invention further relates to a lighting system for illuminating streets, roads or paths comprising a lighting device as explained above, wherein the lighting device is mounted at a height less than 2.0 m preferably between 1.5 and 0.5 m, more preferably between 1.0 and 0.7 m, and most preferably between 0.95 and 1.80 m.

#### 4. Description of the preferred embodiments

**[0020]** In the following, the invention is described exemplarily with reference to the enclosed figures in which

**Figure 1** is a schematic side view of a lighting device according to the invention;

**Figure 2** is a schematic view of a reflector comprising an essentially saddle-shaped reflection surface;

**Figure 3** is a schematic top view of the reflector shown in figure 1;

**Figure 4** is a schematic side view of the reflector shown in figure 2;

**Figure 5** is a cross-section view along a main axis of the reflection surface;

**Figure 6** is a schematic top view of the reflector shown in figure 2 together with a light source arranged thereby,

**Figure 7** is a schematic view of a light distribution obtained by a device according to the present invention.

**[0021]** Figure 1 is a schematic view of a lighting device

100 comprising preferably a housing 110 in which a light source module is housed, preferably comprising a high brightness light emitting diode (not shown) being arranged above a reflector 120.

**[0022]** As can be taken from figure 1, the reflector 120 is arranged inclined with respect to the horizontal plane (indicated by an auxiliary line 130). In the shown preferred embodiment, the reflector 120 is arranged inclined with respect to the horizontal plane 130 with an angle of about 30° DEG. However, depending on the specific application (e.g. the specific mounting height), the reflector 120 may be arranged with an angle between 20° and 60° DEG, more preferably between 30° and 50° DEG. Notably, by means of the inclined arrangement of the reflector 120, the area to be illuminated by the lighting device 100 can be adjusted.

**[0023]** The lighting device 100 distributes light perpendicular to the surface to be illuminated with an angle 135 greater than 60° DEG. In other embodiments of the lighting device, light can be distributed in a direction perpendicular to the surface to be illuminated with an angle preferably greater than 70° DEG and more preferably greater than 80° DEG, and most preferably, the light is distributed with an angle 85° DEG. Preferably, this angle is measured from a horizontal plane 130 downwards. Notably, the angle of the light distribution perpendicular to the surface to be illuminated can be adjusted by means of the inclined arrangement of the reflector 120 and/or by means of the specific geometry of the reflector 120 (e.g. by means of the specific height of the elevation) and/or by further optical means like a baffle as described in the following.

**[0024]** The lighting device 100 is adapted to be mounted at a height of about 0.95 m. For example, the lighting device 100 can be mounted at a guard rail (not shown) provided at a middle strip of a highway. Notably, the lighting device 100 is preferably mounted at a height lower than the height of a driver of a vehicle, such that the driver is not dazzled by any light laterally emitted by the lighting device 100. However, to ensure that a driver is not dazzled by a lateral light, the lighting device 100 can further comprise a baffle 140 preferably arranged and at least partially surrounding the light source in the horizontal plane 130 or even additionally above the light source.

**[0025]** Figure 2 is a schematic view of the reflector 120 shown in the lighting device 100 in figure 1.

**[0026]** As can be taken from figure 2, the reflector 120 comprises an upper reflection surface 150 having an essentially saddle-shape surface. Notably, the term saddle-shape according to the present invention is to be understood as a structure having a kind of a wave form with a wave crest (i.e. provided by the elevation) positioned at the main axis 160 and two laterally arranged wave troughs (i.e. provided by indentations), wherein the wave crest and the wave troughs convert together, preferably at a central section 170 of the reflection surface 150, thereby providing a commonly known saddle-shape surface.

**[0027]** Figure 3 is a schematical top view of the reflector 120. As can be taken from figure 3, the reflection surface 150 has a shape corresponding to a sector of a circle having a center point in the center section 170, wherein in the shown preferred embodiment, the sector of a circle has an interior angle of about 190° DEG (indicated by the angle 180). Preferably, this interior angle is between 90° and 220° DEG, more preferably between 150° and 200° DEG, and even more preferably between 170° and 190° DEG. As already mentioned, by the positions of the minima (i.e. the indentations), the maximum width (i.e. the maximum angle) of the light distribution in a direction parallel to a surface to be illuminated and perpendicular to the main axis of the reflection surface is provided.

**[0028]** As can be further taken from figure 3, the reflection surface 150 is preferably mirror symmetrical with respect to the main axis 160 of the reflection surface 150.

**[0029]** In figure 3, the minima (i.e. the indentations) are highlighted by auxiliary lines 190. Thus, in the shown preferred embodiment, the two minima are provided at an angle of about +/- 80° DEG with respect to the main axis 160 of the reflection surface 150. Notably, in case a light source is arranged above the central section 170 of the reflection surface 150, light is essentially distributed between both minima, thus providing in the preferred embodiment a light distribution in a direction parallel to a surface to be illuminated and perpendicular to the main axis 160 of the reflection surface 150 with an angle of about 160° DEG. However, depending on the specific application, the minima can be provided at an angle between +/- 50° and +/- 90° DEG, preferably between +/- 60° and +/- 85° DEG, and more preferably between +/- 70° and +/- 80° DEG with respect to the main axis 160 of the reflection surface. Thereby, a wide light distribution can be achieved, preferably with an angle greater than +/- 50° DEG, preferably greater than +/- 70° DEG, and even more preferably greater than +/-75° DEG.

**[0030]** Figure 4 is a side view of the reflector 120 as shown in figures 2 and 3. As can be taken from figure 4, the reflection surface 150 does not comprise any jump discontinuities. In fact, starting from a rearward edge 200, the outer circumference of the reflection surface 150 runs downwards to the shown minima and runs subsequently upwards to the front-tip 210 of the reflection surface 150. Since in the preferred embodiment, the reflection surface 150 is mirror symmetrical with respect to the main axis 160, the circumference at the not shown other side is equally provided.

**[0031]** Figure 5 is a cross-section view along the main axis 160 of the reflection surface 150. As can be taken from figure 5, the main axis 160 is provided by a flat curve slightly directed downwardly from the rear edge 200 to a minima and then slightly directed upwardly to the front-tip 210.

**[0032]** Figure 6 is a schematical top view of the reflector 120, wherein above the center section 170 of the reflection surface 150, a light module 220 comprising a high brightness light emitting diode is arranged. The light mod-

ule 220 is preferably a light source having only a directional light emitting light essentially only in the direction to the reflection surface 150 of the reflector 120. Notably, the use of a high brightness light emitting diode preferred, however, also light emitting diode arrays/clusters and/or chip on board light emitting diode arrangements can be used depending on the specific application. As an alternative or in addition to the arrangement of the light module 220 above the center section (*i.e.* above the main axis 160 of the reflection surface 150), it is also possible to arrange two light sources with an offset with respect to the main axis 160 such that each light source emits light to a predetermined area of the reflection surface 150 (*e.g.* one light source is arranged slightly left of the main axis 160 and a further light source is arranged slightly right of the main axis 160) such that the emitted light of each light sources is directed and assigned to a half of the mirror symmetrical shaped reflection surface 150.

**[0033]** It should be clear to a skilled person that the above shown embodiment is a preferred embodiment, but that, however, also different shapes of the reflection surface can be used, as long as the shape of the reflection surface is essentially saddle-shaped. In particular, the specific use of a lighting device may require, that the reflection surface has to be provided with different gradients, thereby adjusting the emitting light cone. Moreover, even if it is preferred that the reflection surface does not comprise any jump discontinuities, the reflection surface may be provided by discrete surface areas, as long as the transitions between these areas provide an essentially uniform distribution of the light.

### Claims

1. Lighting device (100) for illuminating streets, roads or paths, comprising:
  - at least one light source (220) comprising at least one light emitting diode;
  - at least one reflector (120) comprising an essentially saddle-shaped reflection surface (150);
 wherein the light source (220) is arranged such that at least a part of the emitted light is directed to the reflection surface (150) of the reflector (120); and wherein the light is reflected by the reflection surface (150) in such a way that a wide light distribution of the lighting device (100) is provided at least in a direction parallel to a surface to be illuminated and perpendicular to a main axis (160) of the reflection surface (150).
2. Lighting device (100) according to claim 1, wherein the reflection surface (150) is mirror symmetrical with respect to its main axis (160).
3. Lighting device (100) according to any of the preced-

ing claims, wherein in top view the reflection surface (150) has a shape corresponding to a sector of a circle, preferably having an interior angle between 90° and 220° DEG, more preferably between 150° and 200° DEG, and even more preferably between 170° and 190° DEG.

4. Lighting device (100) according to any of the preceding claims, wherein the reflection surface (150) of the reflector (120) comprises at least two minima (190) provided at an angle between +/- 50° and +/- 90° DEG, preferably between +/- 60° and +/- 85° DEG, and more preferably between +/- 70° and +/- 80° DEG with respect to the main axis (160) of the reflection surface (150).
5. Lighting device (100) according to any of the preceding claims, wherein the reflection surface (150) does not comprise any jump discontinuities.
6. Lighting device (150) according to any of the preceding claims, wherein the reflector (120) is designed and arranged such that in top view, the light is distributed with an angle greater than +/- 50° DEG, preferably greater than +/- 70° DEG, and more preferably greater than +/- 75° DEG with respect to the main axis (160) of the reflection surface (150).
7. Lighting device (100) according to any of the preceding claims, wherein the reflector (120) is designed such that perpendicular to the surface to be illuminated, the light is distributed with an angle greater than 60° DEG, preferably greater than 70° DEG, and more preferably greater than 80° DEG, and most preferably the light is distributed with an angle of about 85° DEG.
8. Lighting device (100) according to any of the preceding claims, wherein adjacent to the reflector (120) at least one baffle (140) is arranged at least partially surrounding the light source preferably in a horizontal plane, wherein the at least one baffle (140) preferably comprises an inward reflection surface for redirecting light to the reflection surface (150) of the reflector (120).
9. Lighting device (100) according to any of the preceding claims, wherein the lighting device (100) comprises a housing (110) in which the reflector (120) and the at least one light source (220) are housed.
10. Lighting device (100) according to any of the preceding claims, wherein the reflector (120) is arranged inclined downwards with its main axis (160) with respect to the horizontal plane (130), preferably with an angle between 20° and 60° DEG, more preferably between 30° and 50° DEG and most preferably between 35° and 45° DEG.

11. Lighting device (100) according to any of the preceding claims, wherein the light source (220) is a directional light source emitting light essentially only in the direction to the reflection surface of the reflector. 5
12. Lighting device (100) according to any of the preceding claims, wherein the at least one light source (220) is arranged above the main axis (160) of the reflection surface (150), preferably in the center of the sector of a circle. 10
13. Lighting device (100) according to any of the preceding claims, wherein the lighting device (100) comprises at least two light sources arranged with an offset with respect to the main axis (160) of the reflection surface (150) such that each light source emits light to a predetermined area of the reflection surface (150). 15
14. Lighting device (100) according to any of the preceding claims, wherein the light source (220) comprises a high brightness light emitting diode, a light emitting diode array/cluster and/or a chip on board light emitting diode arrangement. 20  
25
15. Lighting system for illuminating streets, roads or paths comprising a lighting device (100) according to any of the claims 1 to 14, wherein the lighting device (100) is mounted at a height less than 2.0 m, preferably between 1.5 and 0.5 m, more preferably between 1.0 and 0.7 m, and most preferably between 0.95 and 0.80 m. 30  
35  
40  
45  
50  
55

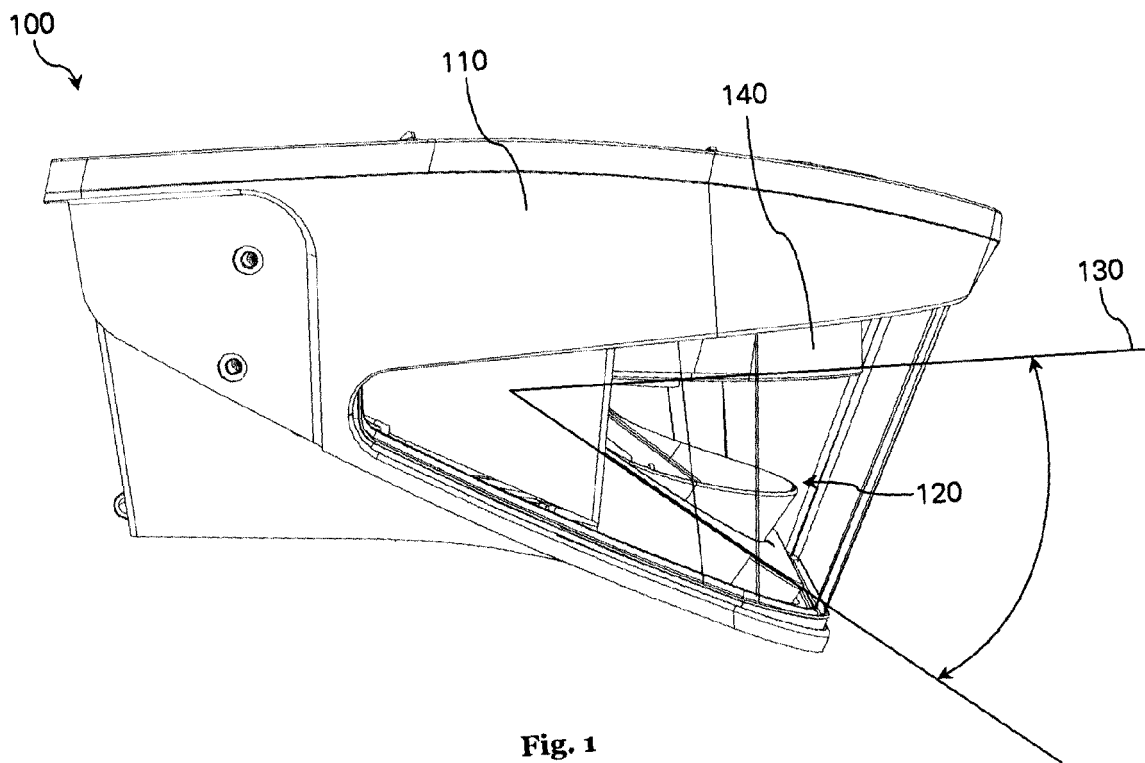
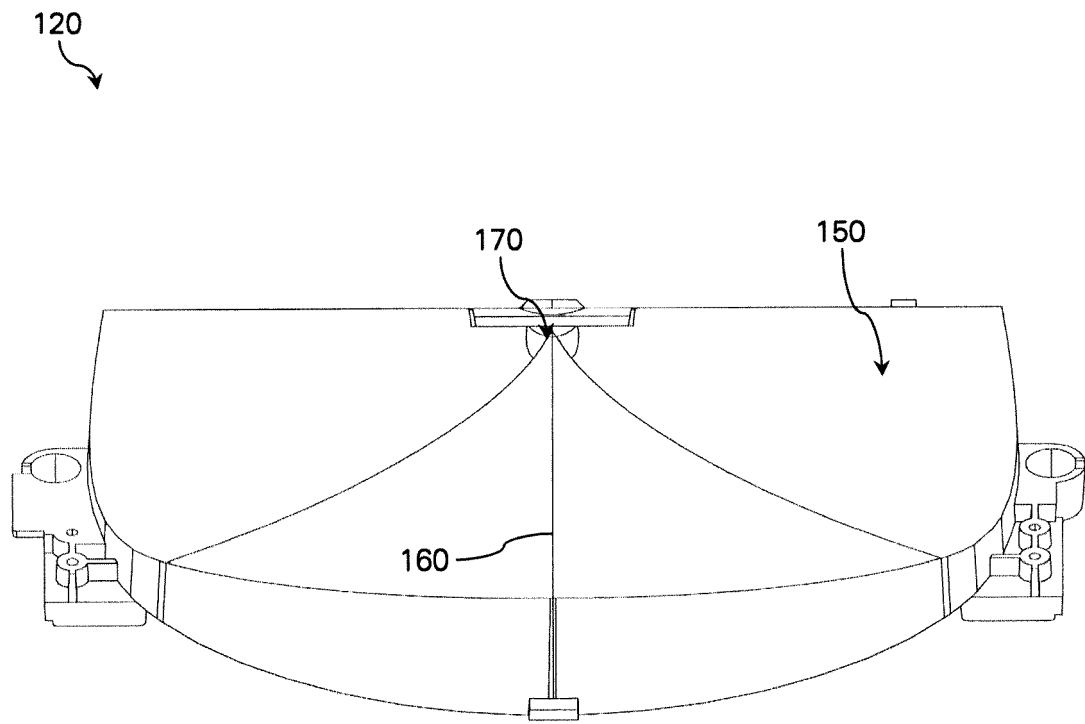
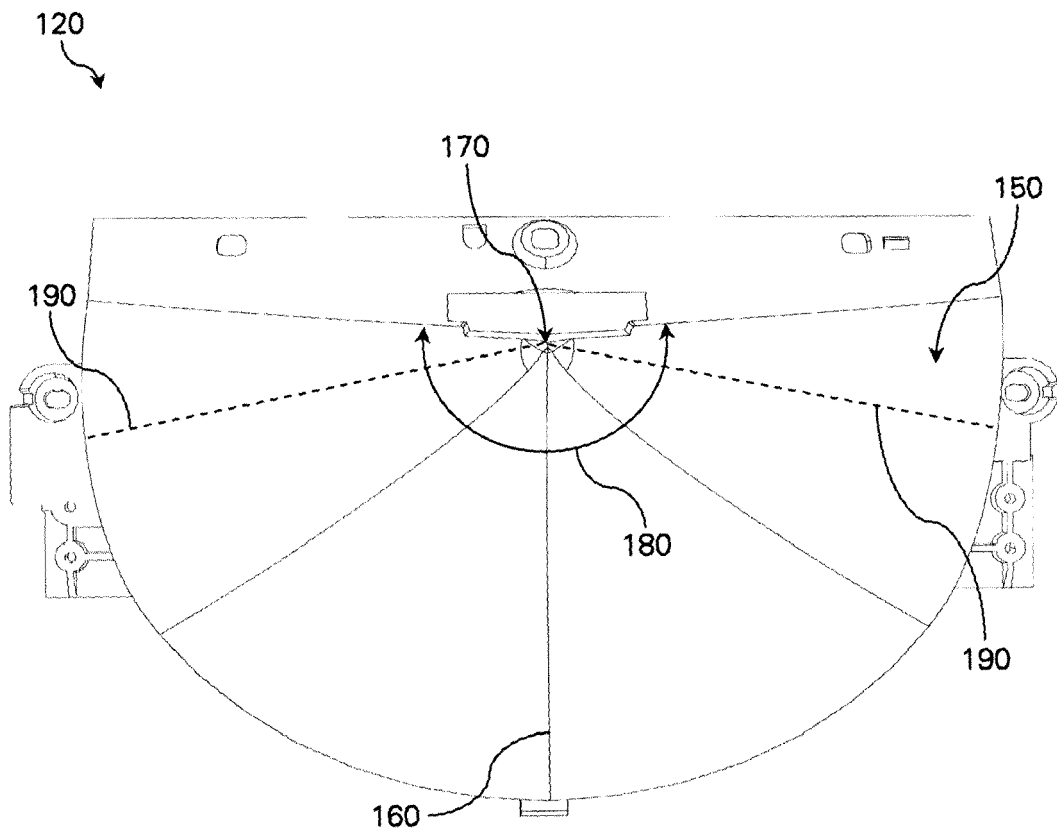

Fig. 1



**Fig. 2**



**Fig. 3**

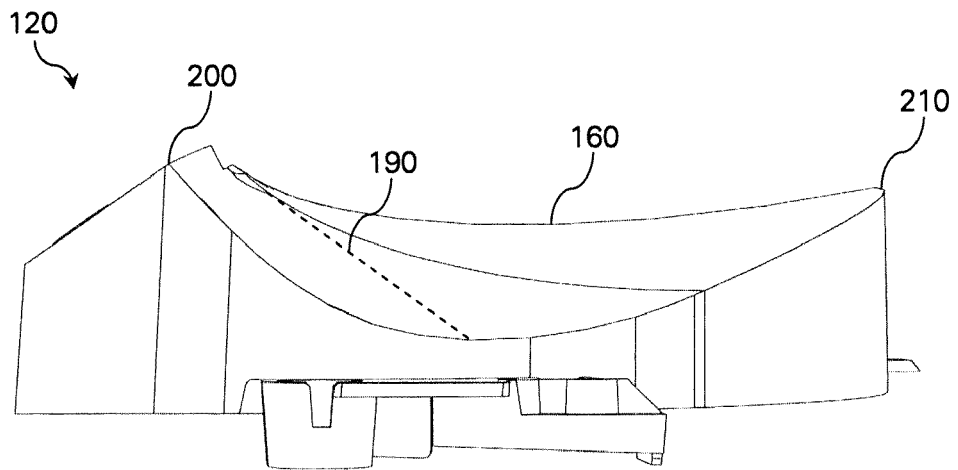

**Fig. 4**

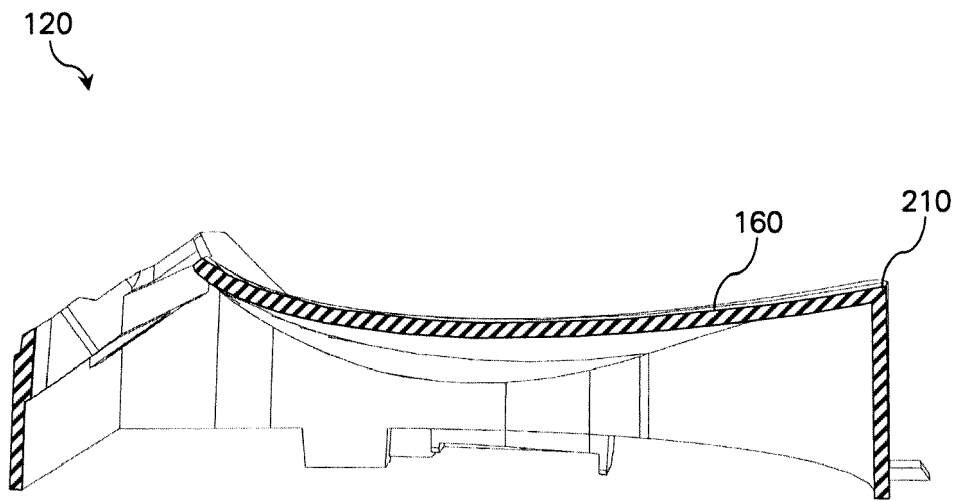

**Fig. 5**

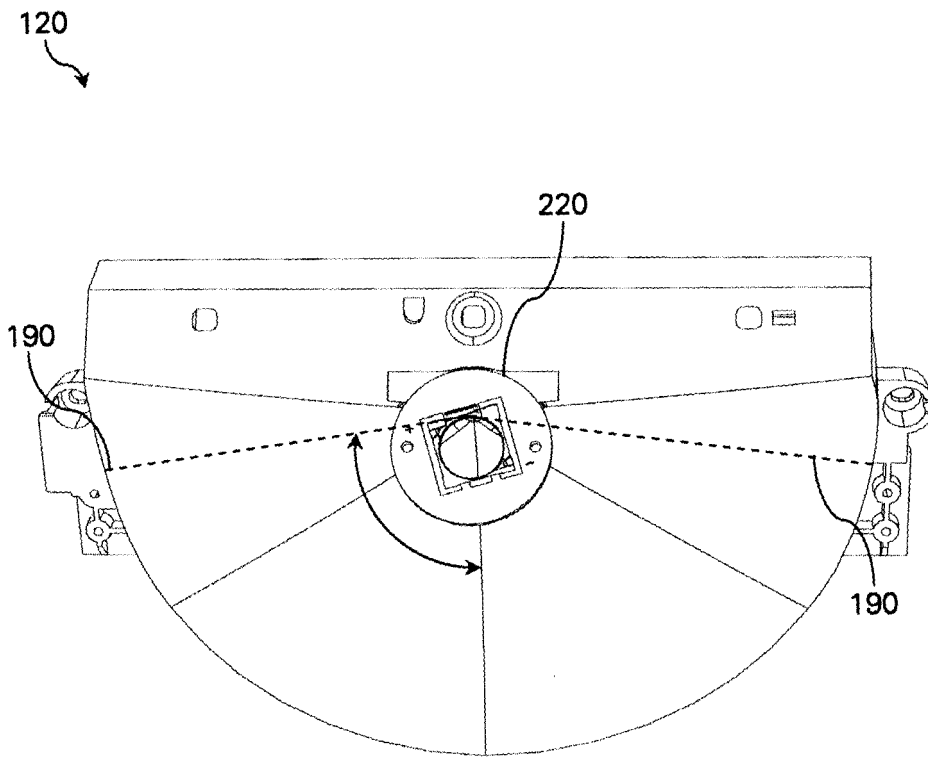

**Fig. 6**

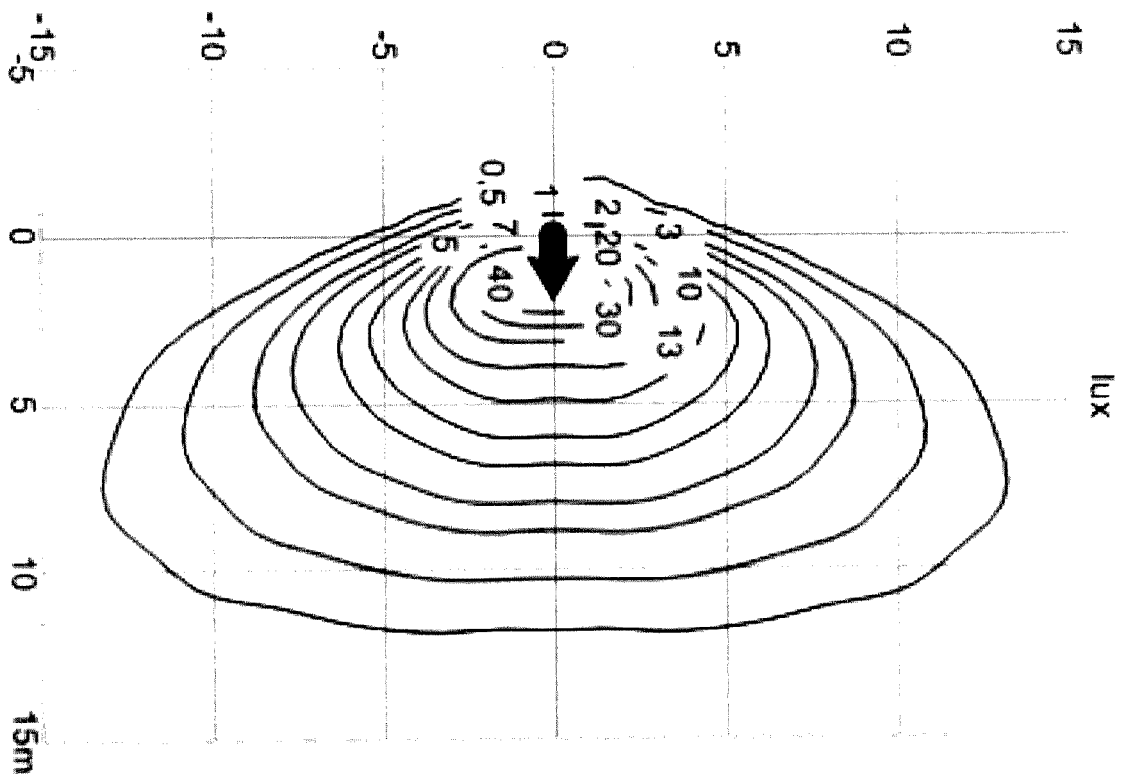

Fig. 7



EUROPEAN SEARCH REPORT

Application Number  
EP 14 36 8005

5

10

15

20

25

30

35

40

45

50

55

DOCUMENTS CONSIDERED TO BE RELEVANT			
Category	Citation of document with indication, where appropriate, of relevant passages	Relevant to claim	CLASSIFICATION OF THE APPLICATION (IPC)
X	WO 2013/136217 A1 (KONINKL PHILIPS NV [NL]) 19 September 2013 (2013-09-19) * page 8, line 3 - line 14; claims 1,7,9; figures 6,7 *	1-12,14,15	INV. F21S8/08 F21V7/09
X	----- EP 1 698 823 A2 (DIALIGHT CORP [US]) 6 September 2006 (2006-09-06) * paragraph [0038] - paragraph [0039]; figures 16B, 17 *	1-3,5-9,11,13,14	
X	----- EP 2 375 130 A1 (THORN EUROPHANE S A [FR]) 12 October 2011 (2011-10-12) * paragraph [0017]; claims 1-4; figures 1,3,4,8,10 *	1,2,4-9,11,13-15	
	-----		
			TECHNICAL FIELDS SEARCHED (IPC)
			F21S F21V F21W
The present search report has been drawn up for all claims			
Place of search		Date of completion of the search	Examiner
The Hague		25 April 2014	Krikorian, Olivier
CATEGORY OF CITED DOCUMENTS		T : theory or principle underlying the invention E : earlier patent document, but published on, or after the filing date D : document cited in the application L : document cited for other reasons ..... & : member of the same patent family, corresponding document	
X : particularly relevant if taken alone Y : particularly relevant if combined with another document of the same category A : technological background O : non-written disclosure P : intermediate document			

EPO FORM 1503 03.82 (P04C01)

**ANNEX TO THE EUROPEAN SEARCH REPORT  
ON EUROPEAN PATENT APPLICATION NO.**

EP 14 36 8005

5

This annex lists the patent family members relating to the patent documents cited in the above-mentioned European search report. The members are as contained in the European Patent Office EDP file on  
The European Patent Office is in no way liable for these particulars which are merely given for the purpose of information.

25-04-2014

10

Patent document cited in search report	Publication date	Patent family member(s)	Publication date
WO 2013136217 A1	19-09-2013	NONE	
-----			
EP 1698823 A2	06-09-2006	EP 1698823 A2	06-09-2006
		US 2006198141 A1	07-09-2006
		US 2009190362 A1	30-07-2009
-----			
EP 2375130 A1	12-10-2011	NONE	
-----			

15

20

25

30

35

40

45

50

55

EPO FORM P0459

For more details about this annex : see Official Journal of the European Patent Office, No. 12/82

**REFERENCES CITED IN THE DESCRIPTION**

*This list of references cited by the applicant is for the reader's convenience only. It does not form part of the European patent document. Even though great care has been taken in compiling the references, errors or omissions cannot be excluded and the EPO disclaims all liability in this regard.*

**Patent documents cited in the description**

- WO 2006092538 A1 [0002]