



(11) **EP 2 916 081 A1**

(12) **EUROPEAN PATENT APPLICATION**

(43) Date of publication:
09.09.2015 Bulletin 2015/37

(51) Int Cl.:
F24F 1/56 (2011.01)

(21) Application number: **15154783.3**

(22) Date of filing: **12.02.2015**

(84) Designated Contracting States:
**AL AT BE BG CH CY CZ DE DK EE ES FI FR GB
GR HR HU IE IS IT LI LT LU LV MC MK MT NL NO
PL PT RO RS SE SI SK SM TR**
Designated Extension States:
BA ME

(71) Applicant: **Mitsubishi Electric Corporation**
Chiyoda-ku
Tokyo 100-8310 (JP)

(72) Inventor: **Tanikawa, Yoshinori**
Tokyo, 102-0073 (JP)

(30) Priority: **03.03.2014 JP 2014040650**

(74) Representative: **Pfenning, Meinig & Partner GbR**
Patent- und Rechtsanwälte
Theresienhöhe 11a
80339 München (DE)

(54) **Outdoor unit**

(57) To prevent, with a simple configuration of a casing of an outdoor unit, reduction in blowing performance, occurrence of noise, and the like, which may be caused by frozen water droplets intruding from an outside of the casing into the casing, particularly into a periphery of a bellmouth and the like provided in a vicinity of an air outlet grille, provided is an outdoor unit, including: a main body (1) including a front panel (2); a top panel (3) covering a top surface of the main body (1); and an air outlet grille

(6) mounted to the front panel (2). The top panel (3) includes a bending piece portion (3a) formed along a periphery of the top panel (3). The air outlet grille (6) includes a fixing piece portion (6a) formed along an edge of the air outlet grille (6). The air outlet grille (6) is mounted so that the fixing piece portion (6a) of the air outlet grille (6) is sandwiched between the front panel (2) and the bending piece portion (3a).

EP 2 916 081 A1

Description

Technical Field

[0001] The present invention relates to an outdoor unit of an air-conditioning apparatus, and more particularly, to an outdoor unit of an air-conditioning apparatus, which is capable of preventing water droplets from being frozen between a fan and a bellmouth.

Background Art

[0002] In an outdoor unit of an air-conditioning apparatus, during heating operation, when water droplets generated from rain, snow, and the like intrude into a casing and a temperature of the outside air is low, the water droplets are frozen between a fan and a bellmouth. This may hinder normal rotation of the fan, or may cause noise.

[0003] Consequently, in the related-art outdoor unit of the air-conditioning apparatus, a protruding part is formed around an air outlet opening of a front panel, and a waterproofing part (slanted part) that abuts on the protruding part is formed on an air outlet grille. When the air outlet grille is mounted to the front panel of the casing, the protruding part and the waterproofing part are brought into intimate contact with each other. Thus, water droplets generated from rainwater and the like are prevented from intruding into the bellmouth and the like provided at the inside of the air outlet grille (see, for example, Patent Literature 1).

Citation List

Patent Literature

[0004] Patent Literature 1: Japanese Unexamined Patent Application Publication No. Hei 08-178365 (see Figs. 1 and 2, etc.)

Summary of Invention

Technical Problem

[0005] However, in the related-art outdoor unit of the air-conditioning apparatus, the protruding part formed around the air outlet opening of the front panel and the waterproofing part (slanted part) formed on the air outlet grille are brought into intimate contact with each other so as to prevent the water droplets from intruding into the casing. Consequently, when the front panel and the air outlet grille are warped or deformed during a constituting process, a gap is formed between the protruding part and the waterproofing part, and hence there is a problem in that intrusion of the water droplets may not be prevented from occurring. Further, also when the front panel and the air outlet grille are deformed due to aged deterioration after installation of the outdoor unit, waterproofing per-

formance cannot similarly be secured.

[0006] The present invention has been made in order to solve the above-mentioned problem, and an object thereof is to prevent, with a simple configuration of a casing of an outdoor unit, reduction in blowing performance, occurrence of noise, and the like, which may be caused by frozen water droplets intruding from an outside of the casing into the casing, particularly into a periphery of a bellmouth and the like provided in a vicinity of an air outlet grille.

Solution to Problem

[0007] According to one embodiment of the present invention, there is provided an outdoor unit, including: a main body including a front panel; a top panel covering a top surface of the main body; and an air outlet grille mounted to the front panel. The top panel includes a bending piece portion formed along a periphery of the top panel. The air outlet grille includes a fixing piece portion formed along an edge of the air outlet grille. The air outlet grille is mounted so that the fixing piece portion of the air outlet grille is sandwiched between the front panel and the bending piece portion.

Advantageous Effects of Invention

[0008] According to the outdoor unit of the one embodiment of the present invention, the air outlet grille is mounted so that the fixing piece portion of the air outlet grille is sandwiched between the front panel and the bending piece portion of the top panel. Consequently, it is possible to prevent, with a simple configuration of the casing of the outdoor unit, reduction in blowing performance, occurrence of noise, and the like, which may be caused by frozen water droplets intruding from the outside of the casing into the casing, particularly into the periphery of the bellmouth and the like provided in the vicinity of the air outlet grille.

Brief Description of Drawings

[0009]

[Fig. 1] Fig. 1 is an exploded perspective view illustrating an outdoor unit according to Embodiment 1.

[Fig. 2] Fig. 2 is an external perspective view illustrating the outdoor unit according to Embodiment 1.

[Fig. 3] Fig. 3 is a cross-sectional view illustrating a periphery of a front panel of the outdoor unit according to Embodiment 1.

[Fig. 4] Fig. 4 is an external perspective view illustrating an outdoor unit according to Embodiment 2.

[Fig. 5] Fig. 5 is a cross-sectional view illustrating a periphery of a front panel of the outdoor unit according to Embodiment 2.

[Fig. 6] Fig. 6 is a cross-sectional view illustrating a periphery of a front panel of an outdoor unit according

to Embodiment 3.

Description of Embodiments

[0010] Now, an outdoor unit according to the present invention is described with reference to the drawings.

[0011] Note that, a configuration described below is merely an example, and the outdoor unit according to the present invention is not limited to the following configuration.

[0012] Further, illustration of detailed structure is simplified or omitted as appropriate.

[0013] Still further, repeated or similar description is simplified or omitted as appropriate.

Embodiment 1

[0014] An overview of structure of an outdoor unit according to Embodiment 1 is described with reference to Figs. 1 to 3.

Fig. 1 is an exploded perspective view illustrating the outdoor unit according to Embodiment 1.

Fig. 2 is an external perspective view illustrating the outdoor unit according to Embodiment 1.

Fig. 3 is a cross-sectional view illustrating a periphery of a front panel of the outdoor unit according to Embodiment 1.

[0015] As illustrated in Fig. 1, a casing of the outdoor unit of an air-conditioning apparatus includes a front panel 2 constituting a front surface side of a main body 1 having a box-like shape, a top panel 3 constituting a top surface of the main body 1, and an air outlet grille 6.

[0016] An air outlet opening 2a is formed into a circular shape in the front panel 2, and a bellmouth 4 having a substantially cylindrical shape is formed around the air outlet opening 2a integrally with the front panel 2.

[0017] Inside the bellmouth 4, blades of a fan 5 are arranged along the cylindrical shape of the bellmouth 4. Further, a heat exchanger (not shown) is arranged on a back surface side of the main body 1, which is opposed to the front panel 2.

[0018] Along a peripheral edge of the main body 1 on the top surface side, a vertical stepped portion 1 a and a horizontal stepped portion 1 b are formed. The vertical stepped portion 1 a has a vertical surface on an inner side of the casing with respect to a side wall surface of the main body 1, and the horizontal stepped portion 1 b horizontally connects the side wall surface and the vertical stepped portion 1 a of the main body 1. A bending piece portion 3a formed along an outer periphery of the top panel 3 is fitted onto the vertical stepped portion 1 a, and closes the top surface of the main body 1, to thereby form the casing of the outdoor unit. Then, an outer surface of the bending piece portion 3a of the top panel 3 is flush with the side wall surface of the main body 1.

[0019] In a front view of the main body 1, the air outlet

grille 6 has, for example, a rectangular shape. A plurality of flat-plate-like louvers 6c define openings that allow the outside air, which is to be blown by the fan 5, to flow therethrough for heat exchange.

[0020] Along an upper edge of the air outlet grille 6, there are formed a fixing piece portion 6a, and an inclined tongue portion 6b formed continuously with the fixing piece portion 6a.

[0021] As illustrated in Fig. 3, the fixing piece portion 6a has a plate-like shape, and is formed so as to extend upward from a back surface side of the air outlet grille 6. Further, when viewed from a front surface of the air outlet grille 6, the fixing piece portion 6a is formed along a widthwise direction of the air outlet grille 6.

[0022] The fixing piece portion 6a is fixed along the vertical stepped portion 1 a of the front panel 2 of the main body 1 so that an air outlet plane of the air outlet grille 6 is substantially vertical when the air outlet grille 6 is mounted to the main body 1.

[0023] The inclined tongue portion 6b is formed so as to extend with a downward inclination from a lower end of the fixing piece portion 6a toward the front surface side of the main body 1. A front end portion of the inclined tongue portion 6b is substantially flush with front end portions of the plurality of louvers 6c.

[0024] As materials for the components, for example, a steel sheet may be adopted for the main body 1 and the top panel 3, and a resin may be adopted for the air outlet grille 6 and the fan 5. However, materials for the components are not limited thereto.

[0025] Next, description is made of a process of assembling components provided around the air outlet grille 6 of the outdoor unit according to Embodiment 1.

[0026] First, the air outlet grille 6 is temporarily mounted so as to cover the air outlet opening 2a of the front panel 2 of the main body 1. Then, as illustrated in Fig. 3, the air outlet grille 6 is temporarily mounted so that the back surface side of the fixing piece portion 6a formed along the upper edge of the air outlet grille 6 abuts on the front surface side of the vertical stepped portion 1 a of the front panel 2 of the main body 1, and that a lower surface of the fixing piece portion 6a abuts on the horizontal stepped portion 1 b of the main body 1.

[0027] Next, the top panel 3 is mounted from an upper surface side of the main body 1, and the bending piece portion 3a of the top panel 3 is fitted onto the vertical stepped portion 1 a of the main body 1. Thus, the fixing piece portion 6a of the air outlet grille 6 is sandwiched between the vertical stepped portion 1 a of the front panel 2 of the main body 1 and the bending piece portion 3a of the top panel 3. Then, the inclined tongue portion 6b is shaped so as to extend with a downward inclination from the lower end of the fixing piece portion 6a toward the front surface side of the main body 1.

[0028] Finally, a lower portion of the air outlet grille 6 is fixed to the front panel 2 with engaging means, such as screws and engaging claws. Thus, mounting of the air outlet grille 6 to the main body 1 is completed.

[0029] When the outdoor unit according to Embodiment 1 is assembled in the above-mentioned manner, an upper surface of the inclined tongue portion 6b of the air outlet grille 6 is positioned below the bending piece portion 3a of the top panel 3 under a state in which the fixing piece portion 6a is mounted to the main body 1, and the upper surface of the inclined tongue portion 6b has a surface inclined downward toward the front surface side of the main body 1.

[0030] Next, description is made of actions when the outdoor unit according to Embodiment 1 is operated.

[0031] When the fan 5 of the outdoor unit is driven so as to rotate, the outside air that is present outside the main body 1 is sucked into the inside of the main body 1 from the back surface side of the main body 1. The heat exchanger (not shown) is disposed on the back surface side of the main body 1. The heat exchanger functions as a condenser when an indoor unit performs cooling operation, and functions as an evaporator when the indoor unit performs heating operation.

[0032] The outside air, which has passed through the heat exchanger, is blown by the blades of the fan 5 to the front surface side of the main body 1 of the outdoor unit, and then is blown out from the air outlet opening 2a of the front panel 2 through an inner wall surface side of the cylindrical bellmouth 4. The outside air blown out from the air outlet opening 2a passes between the louvers 6c of the air outlet grille 6, and is discharged from the main body 1 of the outdoor unit.

[0033] Now, description is made of a flow of water droplets generated from rain, snow, and the like when the water droplets fall down onto the outdoor unit according to Embodiment 1.

[0034] The water droplets, which are generated from rain, snow, and the like coming down onto the top panel 3 of the outdoor unit, fall down onto the inclined tongue portion 6b of the air outlet grille 6 along the bending piece portion 3a from the top panel 3 illustrated in Fig. 3. The upper surface of the inclined tongue portion 6b includes the surface inclined downward toward the front surface side of the main body 1, and hence the water droplets flow over the inclined tongue portion 6b toward the front surface side of the main body 1, and then fall down from the front end portion of the inclined tongue portion 6b. The water droplets, which have thus fallen down, fall downward along surfaces of the louvers 6c. Alternatively, when the fan 5 is driven so as to rotate, the water droplets fall down while being carried off by a blown-out airflow further toward the front surface side of the main body 1.

[0035] Description is made of effects obtained with the configuration of the outdoor unit according to Embodiment 1.

[0036] As described above, in the casing of the outdoor unit according to Embodiment 1, the fixing piece portion 6a of the air outlet grille 6 is arranged so as to be sandwiched between the vertical stepped portion 1a of the front panel 2 of the main body 1 and the bending piece portion 3a of the top panel 3. Thus, the water droplets,

which are generated from rain, snow, and the like coming down onto the inclined tongue portion 6b, are dammed up by the fixing piece portion 6a without intruding into the main body 1.

[0037] In particular, in the weather such as rain or snow, in the case where the heat exchanger of the outdoor unit functions as the evaporator, when a temperature of the air having passed through the heat exchanger is reduced and thus the water droplets are present in the main body 1, the water droplets may be frozen. In particular, when the water droplets are frozen on the bellmouth 4 and the like provided around the fan 5, reduction in blowing performance of the fan 5, occurrence of noise, breakage of the fan 5, and the like may be caused. However, the casing of the outdoor unit according to Embodiment 1 does not allow the intrusion of the water droplets into a periphery of the bellmouth 4, thereby being capable of securing the blowing performance of the fan 5 and preventing the breakage of the fan 5. Further, even when the front panel 2 and the air outlet grille 6 are warped or deformed, as long as the fixing piece portion 6a is arranged between the bending piece portion 3a and the vertical stepped portion 1a of the front panel 2, the water droplets do not fall down to the bellmouth 4 side. Consequently, the same effects as the above-mentioned effects may be obtained.

Embodiment 2

[0038] An overview of structure of an outdoor unit according to Embodiment 2 is described with reference to Figs. 4 and 5.

[0039] Fig. 4 is an external perspective view illustrating the outdoor unit according to Embodiment 2.

[0040] Fig. 5 is a cross-sectional view illustrating a periphery of a front panel of the outdoor unit according to Embodiment 2.

[0041] The outdoor unit according to Embodiment 2 is similar to the outdoor unit according to Embodiment 1 in the basic configuration in which the fixing piece portion 6a of the air outlet grille 6 is sandwiched between the vertical stepped portion 1a of the front panel 2 of the main body 1 and the bending piece portion 3a of the top panel 3. However, in Embodiment 1, the air outlet grille 6 has such a configuration that the inclined tongue portion 6b is formed so as to extend from the lower end of the fixing piece portion 6a to the front surface side of the main body 1, whereas a configuration of an upper edge of the air outlet grille 6 is different in Embodiment 2. Therefore, the differences from the air outlet grille 6 according to Embodiment 1 are described.

[0042] As illustrated in Fig. 4, the upper edge of the air outlet grille 6 of the outdoor unit according to Embodiment 2 includes a lateral inclined tongue portion 6d having such a shape that a center is highest and downward inclined surfaces extend from the center laterally. The lateral inclined tongue portion 6d is formed so as to extend from the lower end of the fixing piece portion 6a to the front

surface side of the main body 1.

[0043] Further, as illustrated in Fig. 5, in cross-sectional view of the front panel 2, the lateral inclined tongue portion 6d is shaped so as to have a horizontal upper surface. Note that, description is made of an example in which the upper surface of the lateral inclined tongue portion 6d is horizontal in cross-sectional view of the front panel 2 as described above. However, similarly to the inclined tongue portion 6b according to Embodiment 1, the lateral inclined tongue portion 6d may further have a downward inclination extending toward the front surface side of the main body 1.

[0044] A process of assembling components provided around the air outlet grille 6 of the outdoor unit according to Embodiment 2 is carried out similarly to that of Embodiment 1. When the outdoor unit according to Embodiment 2 is assembled, as illustrated in Fig. 5, the upper surface of the lateral inclined tongue portion 6d of the air outlet grille 6 is positioned below the bending piece portion 3a of the top panel 3, and includes downward inclined surfaces extending laterally when viewed from the front surface side of the main body 1.

[0045] Next, description is made of a flow of water droplets generated from rain, snow, and the like in a case where the water droplets fall down onto the outdoor unit according to Embodiment 2.

[0046] The water droplets, which are generated from rain, snow, and the like coming down onto the top panel 3 of the outdoor unit, fall down onto the lateral inclined tongue portion 6d of the air outlet grille 6 along the bending piece portion 3a from the top panel 3 illustrated in Fig. 5. The upper surface of the lateral inclined tongue portion 6d includes the downward inclined surfaces extending laterally in front view of the main body 1, and hence the water droplets flow over the lateral inclined tongue portion 6d separately in rightward and leftward directions, and then fall down from both right and left end portions of the lateral inclined tongue portion 6d. The water droplets that have thus fallen down fall downward along both end portions of the louvers 6c.

[0047] Note that, in Fig. 4, description is made of an example in which the upper surface of the lateral inclined tongue portion 6d includes the downward inclined surfaces extending laterally in front view of the main body 1. However, the upper surface of the lateral inclined tongue portion 6d may include an inclined surface having a downward inclination extending in one of the rightward and leftward directions.

[0048] Description is made of effects obtained with the configuration of the outdoor unit according to Embodiment 2.

[0049] Similarly to Embodiment 1, in the casing of the outdoor unit according to Embodiment 2, there is adopted such a configuration that the fixing piece portion 6a of the air outlet grille 6 is arranged so as to be sandwiched between the vertical stepped portion 1a of the front panel 2 of the main body 1 and the bending piece portion 3a of the top panel 3, and that the lateral inclined tongue

portion 6d is formed so as to extend from the lower end of the fixing piece portion 6a toward the front surface side of the main body 1. Thus, the water droplets, which are generated from rain, snow, and the like coming down onto the lateral inclined tongue portion 6d, are dammed up by the fixing piece portion 6a without intruding into the main body 1.

[0050] In particular, in the weather such as rain or snow, in a case where the heat exchanger of the outdoor unit functions as the evaporator, when a temperature of the air having passed through the heat exchanger is reduced and thus the water droplets are present in the main body 1, the water droplets may be frozen. In particular, when the water droplets are frozen on the bellmouth 4 and the like provided around the fan 5, reduction in blowing performance of the fan 5, occurrence of noise, breakage of the fan 5, and the like may be caused. However, similarly to Embodiment 1, the casing of the outdoor unit according to Embodiment 2 does not allow intrusion of the water droplets into a periphery of the bellmouth 4, thereby being capable of securing the blowing performance of the fan 5 and preventing the breakage of the fan 5. Further, even when the front panel 2 and the air outlet grille 6 are warped or deformed, as long as the fixing piece portion 6a is arranged between the bending piece portion 3a and the vertical stepped portion 1a of the front panel 2, the water droplets do not fall down to the bellmouth 4 side. Consequently, the same effects as the above-mentioned effects can be obtained.

Embodiment 3

[0051] An overview of structure of an outdoor unit according to Embodiment 3 is described with reference to Fig. 6.

[0052] Fig. 6 is a cross-sectional view illustrating a periphery of a front panel of the outdoor unit according to Embodiment 3.

[0053] The outdoor unit according to Embodiment 3 is similar to the outdoor units according to Embodiments 1 and 2 in the basic configuration in which the fixing piece portion 6a of the air outlet grille 6 is sandwiched between the vertical stepped portion 1a of the front panel 2 of the main body 1 and the bending piece portion 3a of the top panel 3. Further, an air outlet grille according to Embodiment 3 has a common feature in configuration of the upper edge of the air outlet grille 6 having such a shape that a center is highest and downward inclined surfaces extend from the center laterally like the lateral inclined tongue portion 6d according to Embodiment 2. Therefore, the differences from the air outlet grilles 6 according to Embodiments 1 and 2 are described.

[0054] As illustrated in Fig. 4, the upper edge of the air outlet grille 6 of the outdoor unit according to Embodiment 3 includes a lateral inclined tongue portion 6d having such a shape that a center is highest and downward inclined surfaces extend from the center laterally. The lateral inclined tongue portion 6d is formed so as to extend from

the lower end of the fixing piece portion 6a to the front surface side of the main body 1.

[0055] As illustrated in Fig. 6, the lateral inclined tongue portion 6d integrally includes a protruding piece portion 6e arranged on the front surface side of the main body 1 in cross-sectional view of the front panel 2 so as to extend from the lateral inclined tongue portion 6d upright substantially in a vertical direction. The protruding piece portion 6e is formed along a widthwise direction of the air outlet grille 6 when viewed from the front surface side of the air outlet grille 6.

[0056] Further, as illustrated in Fig. 6, in cross-sectional view of the front panel 2, the lateral inclined tongue portion 6d is shaped so as to have a horizontal upper surface. Note that, description is made of an example in which the upper surface of the lateral inclined tongue portion 6d is horizontal in cross-sectional view of the front panel 2 as described above. However, similarly to the inclined tongue portion 6b according to Embodiment 1, the lateral inclined tongue portion 6d may further have a downward inclination extending toward the front surface side of the main body 1.

[0057] A process of assembling components provided around the air outlet grille 6 of the outdoor unit according to Embodiment 3 is carried out similarly to that of Embodiment 1. When the outdoor unit according to Embodiment 3 is assembled, as illustrated in Fig. 6, the upper surface of the lateral inclined tongue portion 6d of the air outlet grille 6 is positioned below the bending piece portion 3a of the top panel 3, and includes downward inclined surfaces extending laterally when viewed from the front surface side of the main body 1. Further, the protruding piece portion 6e is formed on the upper surface of the lateral inclined tongue portion 6d on the front surface side of the main body 1.

[0058] Next, description is made of a flow of water droplets generated from rain, snow, and the like in a case where the water droplets fall down onto the outdoor unit according to Embodiment 3.

[0059] The water droplets, which are generated from rain, snow, and the like coming down onto the top panel 3 of the outdoor unit, fall down onto the lateral inclined tongue portion 6d of the air outlet grille 6 along the bending piece portion 3a from the top panel 3 illustrated in Fig. 6. The upper surface of the lateral inclined tongue portion 6d includes the downward inclined surfaces extending laterally in front view of the main body 1, and the protruding piece portion 6e is formed at an end portion of the lateral inclined tongue portion 6d on the front surface side. Consequently, the water droplets flow over the lateral inclined tongue portion 6d separately in the rightward and leftward directions, and then fall down from both the right and left end portions of the lateral inclined tongue portion 6d. The water droplets that have thus fallen down fall downward along both the end portions of the louvers 6c.

[0060] Description is made of effects obtained with the configuration of the outdoor unit according to Embodi-

ment 3.

[0061] Similarly to Embodiments 1 and 2, in the casing of the outdoor unit according to Embodiment 3, there is adopted such a configuration that the fixing piece portion 6a of the air outlet grille 6 is arranged so as to be sandwiched between the vertical stepped portion 1 a of the front panel 2 of the main body 1 and the bending piece portion 3a of the top panel 3, and that the lateral inclined tongue portion 6d is formed so as to extend from the lower end of the fixing piece portion 6a toward the front surface side of the main body 1. Thus, the water droplets, which are generated from rain, snow, and the like coming down onto the lateral inclined tongue portion 6d, are dammed up by the fixing piece portion 6a without intruding into the main body 1.

[0062] In particular, in the weather such as rain or snow, in a case where the heat exchanger of the outdoor unit functions as the evaporator, when a temperature of the air having passed through the heat exchanger is reduced and thus the water droplets are present in the main body 1, the water droplets may be frozen. In particular, when the water droplets are frozen on the bellmouth 4 and the like provided around the fan 5, reduction in blowing performance of the fan 5, occurrence of noise, breakage of the fan 5, and the like may be caused. However, similarly to Embodiments 1 and 2, the casing of the outdoor unit according to Embodiment 3 does not allow intrusion of the water droplets into a periphery of the bellmouth 4, thereby being capable of securing the blowing performance of the fan 5 and preventing the breakage of the fan 5.

[0063] Further, even when the front panel 2 and the air outlet grille 6 are warped or deformed, as long as the fixing piece portion 6a is arranged between the bending piece portion 3a and the vertical stepped portion 1 a of the front panel 2, the water droplets do not fall down to the bellmouth 4 side. Consequently, the same effects as the above-mentioned effects can be obtained. In addition, the protruding piece portion 6e is formed on the upper surface of the lateral inclined tongue portion 6d on the front surface side of the main body 1, and hence the water droplets do not fall down to the front surface side of the main body 1. Therefore, it is possible to prevent the water droplets from being scattered to the front surface side of the main body 1 by the airflow that is blown out when the fan 5 is driven so as to rotate.

[0064] Embodiments 1 to 3 are described above, but the present invention is not limited to the description of the respective embodiments, and all or part of the respective embodiments may be combined.

Claims

1. An outdoor unit, comprising:

a main body (1) comprising a front panel (2) on a front surface side thereof;

- a top panel (3) covering a top surface of the main body (1); and
 an air outlet grille (6) mounted to the front panel (2),
 the top panel (3) comprising a bending piece portion (3a) formed along a periphery of the top panel (3),
 the air outlet grille (6) comprising a fixing piece portion (6a) formed along an edge of the air outlet grille (6),
 the air outlet grille (6) being mounted so that the fixing piece portion (6a) of the air outlet grille (6) is sandwiched between the front panel (2) and the bending piece portion (3a).
- 5
10
15
2. The outdoor unit of claim 1, wherein the air outlet grille (6) further comprises an inclined tongue portion (6b) formed so as to extend from a lower end of the fixing piece portion (6a).
- 20
3. The outdoor unit of claim 2, wherein an upper surface of the inclined tongue portion (6b) comprises a downward inclination extending toward the front surface side of the main body (1).
- 25
4. The outdoor unit of claim 2, wherein an upper surface of the inclined tongue portion (6b) comprises a downward inclination extending in one of rightward and leftward directions when viewed from the front surface side of the main body (1).
- 30
5. The outdoor unit of claim 2, wherein an upper surface of the inclined tongue portion (6b) comprises a downward inclination extending toward both right and left ends of the inclined tongue portion (6b) when viewed from the front surface side of the main body (1).
- 35
6. The outdoor unit of any one of claims 2 to 5, wherein the inclined tongue portion (6b) comprises a protruding piece portion (6e) arranged on the front surface side of the main body (1) so as to extend from the inclined tongue portion (6b) upright substantially in a vertical direction.
- 40
7. The outdoor unit of any one of claims 1 to 6, further comprising a vertical stepped portion (1 a) formed along an upper edge of the front panel (2) so as to be stepped with respect to a plane in which the front panel (2) is formed,
 wherein the air outlet grille (6) is mounted so that the fixing piece portion (6a) is sandwiched between the vertical stepped portion (1 a) and the bending piece portion (3a).
- 45
50
55

FIG. 1

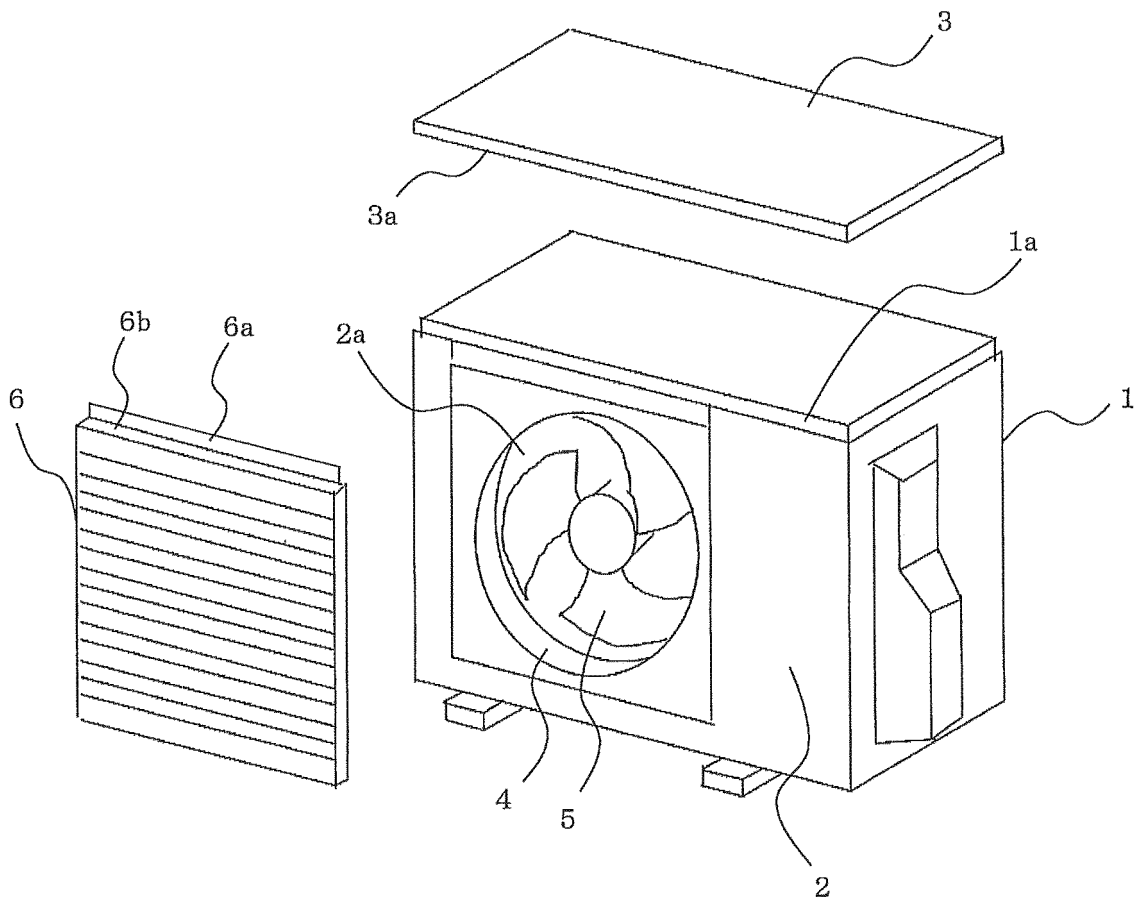

FIG. 2

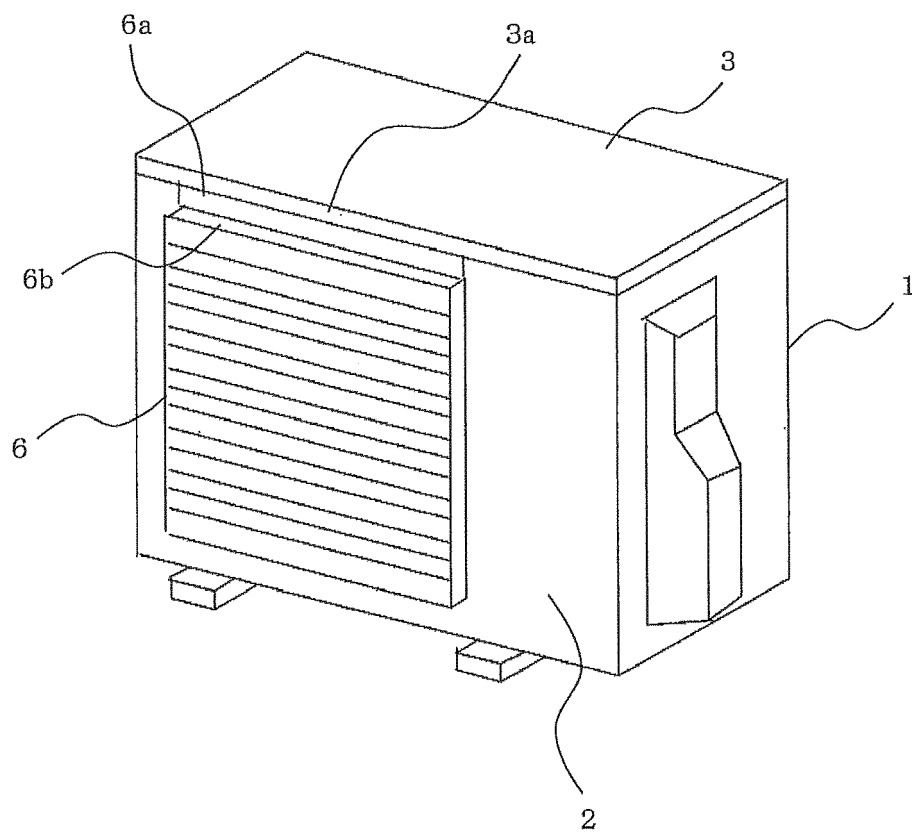

FIG. 3

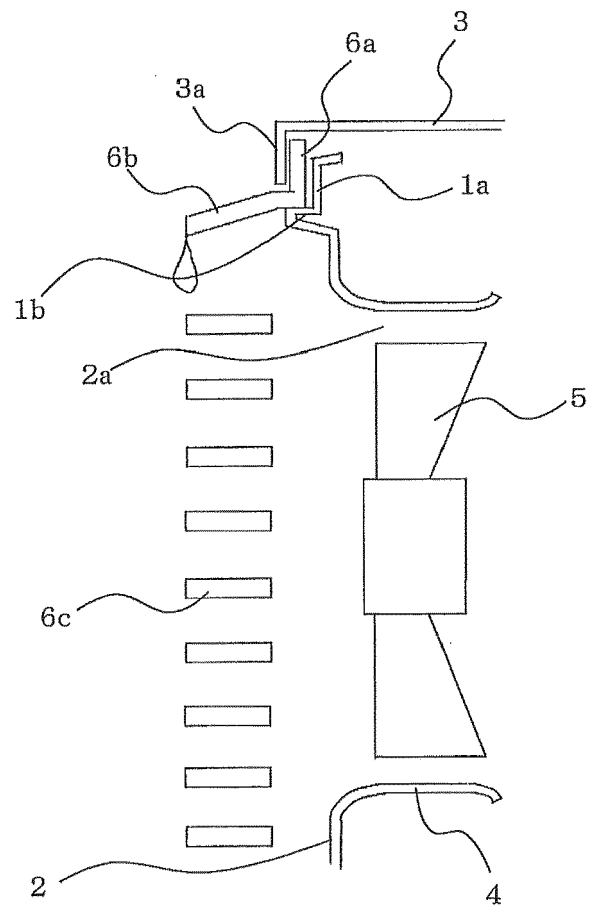

FIG. 4

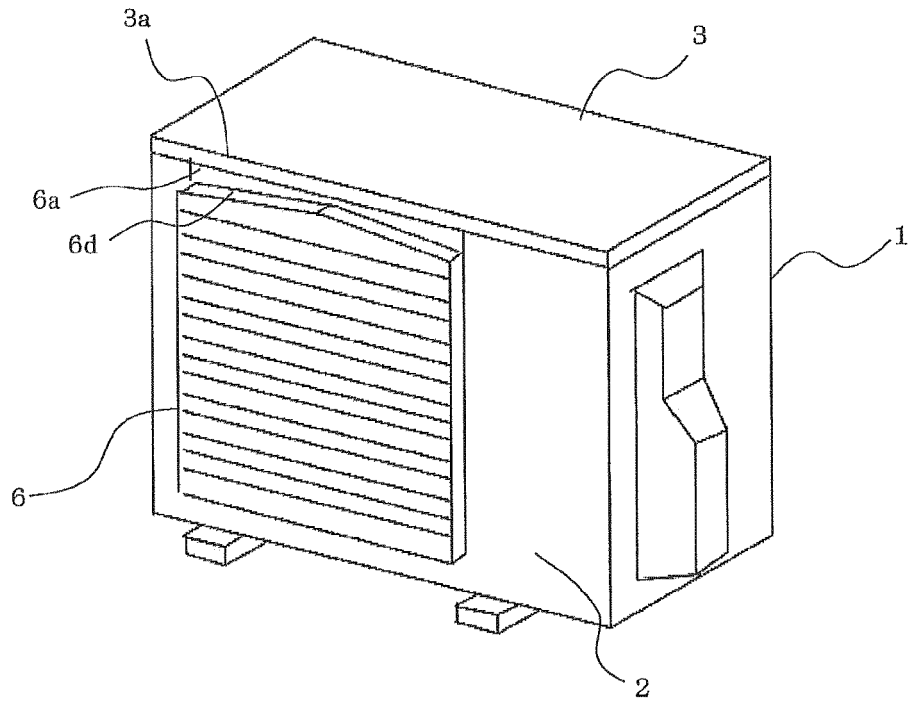

FIG. 5

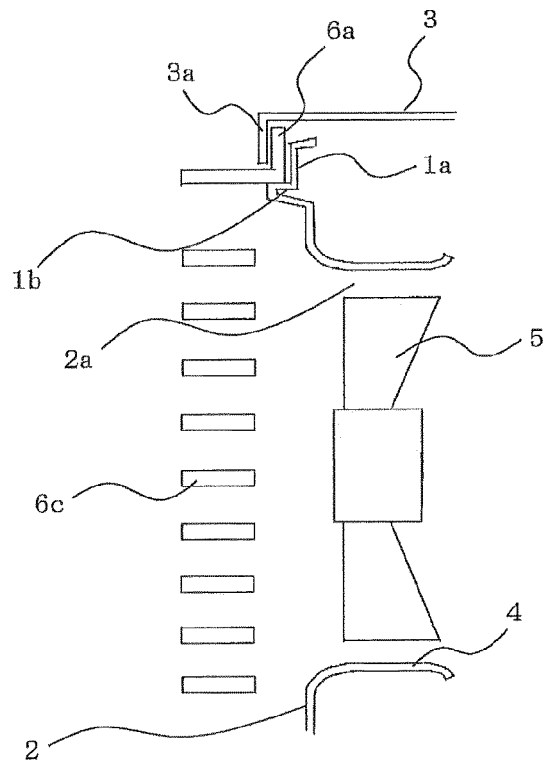
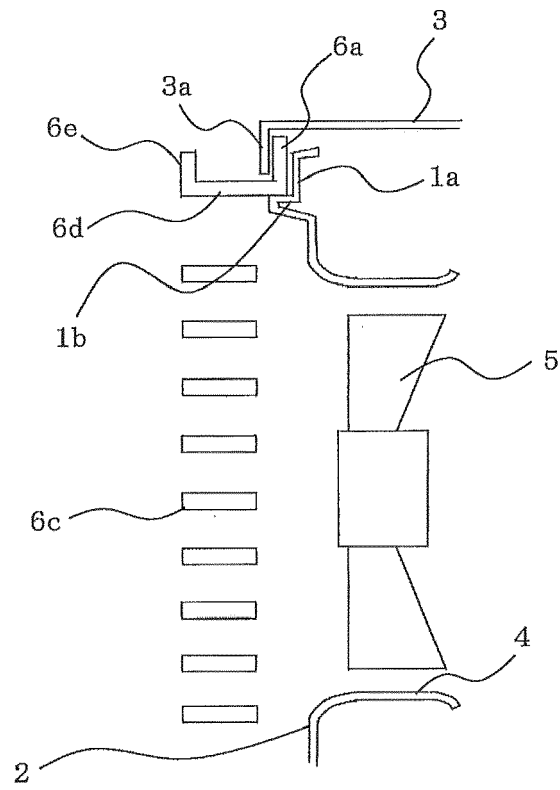

FIG. 6





EUROPEAN SEARCH REPORT

Application Number
EP 15 15 4783

5

10

15

20

25

30

35

40

45

50

55

DOCUMENTS CONSIDERED TO BE RELEVANT			
Category	Citation of document with indication, where appropriate, of relevant passages	Relevant to claim	CLASSIFICATION OF THE APPLICATION (IPC)
X	JP H08 200744 A (MITSUBISHI ELECTRIC CORP) 6 August 1996 (1996-08-06) * abstract; figures 17-25 *	1-7	INV. F24F1/56
X	JP 2008 170082 A (MATSUSHITA ELECTRIC IND CO LTD) 24 July 2008 (2008-07-24) * abstract; figure 5 *	1-7	
A	JP 2010 145063 A (PANASONIC CORP) 1 July 2010 (2010-07-01) * abstract; figures 1-4 *	1-7	
A	EP 1 666 801 A1 (FUJITSU GENERAL LTD [JP]) 7 June 2006 (2006-06-07) * paragraph [0100] - paragraph [0101]; figures 3,5,17 *	1-7	
A	JP 2008 256296 A (MATSUSHITA ELECTRIC IND CO LTD) 23 October 2008 (2008-10-23) * abstract; figures 1-12 *	1-7	
			TECHNICAL FIELDS SEARCHED (IPC)
			F24F
The present search report has been drawn up for all claims			
Place of search Munich		Date of completion of the search 24 June 2015	Examiner Anconetani, Mirco
CATEGORY OF CITED DOCUMENTS X : particularly relevant if taken alone Y : particularly relevant if combined with another document of the same category A : technological background O : non-written disclosure P : intermediate document		T : theory or principle underlying the invention E : earlier patent document, but published on, or after the filing date D : document cited in the application L : document cited for other reasons & : member of the same patent family, corresponding document	

EPO FORM 1503 03.02 (P04/C01)

ANNEX TO THE EUROPEAN SEARCH REPORT
ON EUROPEAN PATENT APPLICATION NO.

EP 15 15 4783

5

This annex lists the patent family members relating to the patent documents cited in the above-mentioned European search report. The members are as contained in the European Patent Office EDP file on The European Patent Office is in no way liable for these particulars which are merely given for the purpose of information.

24-06-2015

10

Patent document cited in search report	Publication date	Patent family member(s)	Publication date
JP H08200744 A	06-08-1996	JP 3216462 B2 JP H08200744 A	09-10-2001 06-08-1996
JP 2008170082 A	24-07-2008	NONE	
JP 2010145063 A	01-07-2010	NONE	
EP 1666801 A1	07-06-2006	AU 2005209616 A1 CN 1782568 A EP 1666801 A1 ES 2443223 T3 JP 2006162094 A KR 20060061760 A MY 151800 A US 2006130516 A1	22-06-2006 07-06-2006 07-06-2006 18-02-2014 22-06-2006 08-06-2006 14-07-2014 22-06-2006
JP 2008256296 A	23-10-2008	NONE	

15

20

25

30

35

40

45

50

55

EPO FORM P0459

For more details about this annex : see Official Journal of the European Patent Office, No. 12/82

REFERENCES CITED IN THE DESCRIPTION

This list of references cited by the applicant is for the reader's convenience only. It does not form part of the European patent document. Even though great care has been taken in compiling the references, errors or omissions cannot be excluded and the EPO disclaims all liability in this regard.

Patent documents cited in the description

- JP HEI08178365 B [0004]