



(11) **EP 2 920 354 B1**

(12) **EUROPEAN PATENT SPECIFICATION**

(45) Date of publication and mention of the grant of the patent:
10.06.2020 Bulletin 2020/24

(21) Application number: **13789796.3**

(22) Date of filing: **12.11.2013**

(51) Int Cl.:
D06F 34/14 ^(2020.01) **D06F 58/20** ^(2006.01)

(86) International application number:
PCT/EP2013/073643

(87) International publication number:
WO 2014/076093 (22.05.2014 Gazette 2014/21)

(54) **METHOD OF OPERATING A HEAT PUMP LAUNDRY DRYER AND HEAT PUMP LAUNDRY DRYER OR HEAT PUMP WASHING MACHINE HAVING DRYING FUNCTION**

VERFAHREN FÜR DEN BETRIEB EINES WÄSCHETROCKNERS MIT WÄRMEPUMPE UND WÄSCHETROCKNER MIT WÄRMEPUMPE ODER WASCHMASCHINE MIT WÄRMEPUMPE MIT TROCKNUNGSFUNKTION

PROCÉDÉ D'UTILISATION D'UN SÈCHE-LINGE AVEC POMPE À CHALEUR, SÈCHE-LINGE AVEC POMPE À CHALEUR OU MACHINE À LAVER AVEC POMPE À CHALEUR AYANT UNE FONCTION DE SÉCHAGE

(84) Designated Contracting States:
AL AT BE BG CH CY CZ DE DK EE ES FI FR GB GR HR HU IE IS IT LI LT LU LV MC MK MT NL NO PL PT RO RS SE SI SK SM TR

(30) Priority: **16.11.2012 EP 12192939**

(43) Date of publication of application:
23.09.2015 Bulletin 2015/39

(73) Proprietor: **Electrolux Home Products Corporation N.V.**
1130 Brussels (BE)

(72) Inventors:
• **BISARO, Michele**
I-33080 Porcia (PN) (IT)
• **RAGOGNA, Roberto**
I-33080 Porcia (PN) - Italy (IT)

(74) Representative: **Electrolux Group Patents**
AB Electrolux
Group Patents
105 45 Stockholm (SE)

(56) References cited:
EP-A1- 2 058 427 EP-A1- 2 460 927
EP-A2- 1 884 586 DE-A1- 4 409 607
DE-A1- 19 853 234

EP 2 920 354 B1

Note: Within nine months of the publication of the mention of the grant of the European patent in the European Patent Bulletin, any person may give notice to the European Patent Office of opposition to that patent, in accordance with the Implementing Regulations. Notice of opposition shall not be deemed to have been filed until the opposition fee has been paid. (Art. 99(1) European Patent Convention).

Description

[0001] The invention relates to a method of operating a heat pump laundry dryer or washing machine having a cooling fan unit for cooling a compressor of the dryer and the invention relates to a heat pump laundry dryer or a heat pump washing machine having drying function.

[0002] EP 2 212 463 B1 discloses a household appliance for drying laundry. A heat pump unit and means for cooling a component thereof are arranged in a housing of the appliance. The means for cooling comprises a blower or fan which is adapted to convey cooling air from the outside of the appliance to the component. A temperature sensor is disposed in the housing for generating a signal dependent from a temperature within the housing, wherein the temperature sensor may be arranged adjacent to a heat exchanger for condensing a refrigerant. A control unit of the appliance is programmed to operate the blower in response to the signal. According to an embodiment a motor for driving the blower may have a fixed speed, wherein the control unit is adapted to operate the motor intermittently in response to the temperature signal. According to another embodiment a variable-speed motor is provided, wherein the control unit is adapted to operate the motor at varying speeds depending on the temperature signal.

[0003] EP 1 884 586 A2 discloses a laundry dryer comprising a process air circuit and a heat pump circuit with a condenser, a throttle, and an evaporator. The process air circuit is adapted to guide process air through a drum, cool and thereby dry process air at the evaporator, and to re-heat process air at the condenser. An additional heat exchanger is arranged in the heat pump circuit between the condenser and the throttle and serves for removing heat energy from the heat pump circuit. In an embodiment, a fan is arranged for cooling the additional heat exchanger, the fan being optionally controlled in dependency of a temperature of the process air and/or a temperature in the heat pump circuit.

[0004] DE 44 09 607 A1 is related to a drying machine as well as a set of drying processes in a drying machine comprising a closed process air circuit, wherein process air is guided in the process air circle through the drying chamber, and a heat pump system with a closed refrigerant circuit, wherein a refrigerant is guided through an evaporator, a compressor and a condenser. The process air leaving the drying chamber is dehumidified in a heat exchanger which comprises the evaporator and is then re-heated in a heater that incorporates the condenser. A means for cooling the refrigerant is arranged at least at one of the components of the refrigerant circuit and may be controlled in dependency of a refrigerant temperature.

[0005] EP 198 53 234 A1 presents a laundry dryer having a heat pump system and a closed process air circuit wherein a process air blower conveys process air through a laundry drum, a refrigerant evaporator, and a refrigerant condenser. A heat balancing means is arranged in the refrigerant circuit of the heat pump system between the refrigerant evaporator and the compressor. An additional fan is adapted to create a stream of ambient air moving across the surface of the heat balancing means. In that way, additional heat energy can be introduced into the heat pump system as long as the refrigerant is relatively cool whereas heat energy is removed when the refrigerant becomes relatively hot during the course of a drying process. According to the teachings of the document, the additional fan is preferably operated continuously throughout the whole drying process as well as during an optional cool-down phase at the end of the drying program.

[0006] EP 2 058 427 A1 teaches a household appliance for drying articles, the appliance comprising a drying chamber, a closed process-air circuit with a first blower, a heat pump unit, a condensate collector, a control unit, and an additional cooling means with a second blower for cooling at least one component of the heat pump unit. Process air is conveyed by the first blower along the articles to be dried inside the drying chamber. The heat pump unit is adapted for extracting humidity from the process air, and the resulting condensate is collected within the condensate collector. By means of the second blower, air from the outside of the appliance is fed to the additional cooling means serving for removal of excess heat generated by the heat pump unit. Optionally, the second blower is operated by the control unit in response to a signal created by a temperature sensor which is preferably disposed at the heat pump unit. It is an object of the invention to provide a heat pump laundry dryer or washing machine having drying function and a method of operating a heat pump laundry dryer or washing machine which provides an improved drying performance.

[0007] It is an object of the invention to provide a heat pump laundry dryer or washing machine having drying function and a method of operating a heat pump laundry dryer or washing machine which provides an improved drying performance.

[0008] The invention is defined in claims 1 and 14, respectively. Particular embodiments are set out in the dependent claims.

[0009] According to claim 1, it is provided a method of operating a heat pump laundry dryer or a heat pump washing machine having drying function, wherein the laundry dryer or washing machine comprises:

- a control unit (30) controlling the operation of the laundry dryer or washing machine,
- a laundry drum (18) for treating laundry using process air,
- a process air circuit for circulating the process air,
- a heat pump system (4) having a refrigerant loop, in which the refrigerant fluid is circulated through a first and a

second heat exchanger (10, 12),
a compressor (14) for circulating the refrigerant fluid through the refrigerant loop, and
a cooling fan unit (24) for cooling the compressor (14),
wherein the method comprises: detecting or monitoring one or a plurality of input variables during a running program
5 cycle;
the method further comprises:

determining the end of a program sub-sequence by detecting or monitoring the one or the plurality of input
variables, and
10 modifying or changing an operation parameter set for operating the cooling fan unit upon determining the end
of the program sub-sequence,
wherein the one or the plurality of input variables is at least one of the following input variables:

a) a user selectable input variable, being one or more of:

15 a laundry type,
a drying program type,
a residual laundry humidity,
an energy-saving option,
20 a drying process time-saving option,
the laundry amount,
a final laundry humidity, and
a drying level;

25 b) a working parameter of the laundry drum (18), being one or more of:

a power supply of a drum motor,
a power consumption of a drum motor,
a rotation speed of a drum motor,
30 a voltage, current, or phase supplied to a drum motor,
a motor torque of a drum motor, and
a laundry parameter derived from the power consumption of a drum motor;

35 c) a working parameter of a process air fan (8), being one or more of:

a process air fan rotation speed,
a process air fan motor power supply,
a power consumption,
a process air fan flow rate, and
40 a voltage, current, or phase supplied to a process air fan motor;

d) a working parameter of the heat pump system (4),

e) a working parameter of an electric driving motor (32), being one or more of:

45 a motor power supply,
a motor power consumption, and
a voltage, current, or phase supplied to the motor;

50 f) a working parameter of the compressor (14), being one or more of:

the compressor power consumption,
the compressor speed, and
the compressor motor status;

55 g) a working parameter of a liquid pump or condensate pump;

h) a humidity value of the laundry to be dried;

i) a status of a liquid or condensate level;

j) an environment parameter of the treatment apparatus environment; and

k) a machine alarm status parameter.

[0010] For example the compressor may have a fixed rotational speed or may be a variable speed compressor.

[0011] The cooling fan unit comprises for example at least one fan and a motor for driving the at least one fan. The cooling fan unit is adapted to cool the compressor during a drying operation, i.e. to remove excess heat from the heat pump system, to provide that the energy-efficient steady state or targeted operation state of the heat pump system is maintained during a drying operation (after a warm-up period at the beginning of a drying cycle).

[0012] According to the invention, a drying program or drying cycle comprises a plurality of sub-sequences, i.e. cycle steps or program steps, wherein the duration or end of a cycle step is determined in dependency of one or more input variables. For example a cycle step may be terminated when a predetermined threshold value of an input variable is reached, e.g. a predetermined time is elapsed or a predetermined temperature of the heat pump system is reached. Thus the operation parameter settings of the fan unit, i.e. the cooling power of the fan unit, is adjusted to requirements of each specific drying cycle step, such that the heat pump system operates at all times at best possible conditions. I.e. it is provided that as soon as the heat pump system operates in a steady or balanced state, this operation state is maintained, whereby the drying performance of the treatment apparatus is improved, in particular with respect to energy-efficiency.

[0013] For example an operation parameter set of the cooling fan unit may comprise one or more of the following operation parameters, in particular an arbitrary combination thereof: a fan rotation speed, i.e. a fan flow rate, an On/Off activation power duty ratio, e.g. controlled by driving a cooling fan motor through a PWM (pulse-width modulation) signal to control the fan speed, a threshold temperature above which the cooling fan unit is switched On and below which the fan unit is switched Off, and additionally or alternatively an On/Off time profile (e.g. duty ratio of operational ON/OFF periods), e.g. driving the fan not continuously but through a certain activation rhythm (e.g. 20 sec. ON, 5 sec. OFF).

[0014] A program cycle may be one of the following: a drying cycle, a laundry refreshment cycle, a laundry dry cleaning cycle, a laundry chemical processing cycle, a washing cycle, and an anti-wrinkle cycle. Preferably the program cycle or each of the plurality of program cycles has a first sub-sequence and at least a second sub-sequence, wherein the first sub-sequence has a first operation parameter set for operating the cooling fan unit and the second sub-sequence has a second operation parameter set for operating the cooling fan unit, and wherein the first and second operation parameter sets are different from each other. In other words the method provides a plurality of operation parameter sets, wherein each operation parameter set is different from the other. The plurality of operation parameter sets is provided, i.e. selected and applied, by the control unit which controls the operation of the fan unit.

[0015] A working parameter of heat pump system may be for example a temperature of the refrigerant, in particular the refrigerant temperature at one of the heat exchangers, at the compressor outlet or at the condenser outlet.

[0016] For example a counter for determining a time parameter of a running program cycle may be implemented in the control unit. The counter may be adapted to count time or determine elapsed time from the start of a program cycle, or from the start of a sub-sequence or from the time point of one of the other input parameters reaching or exceeding a predefined value, e.g. a predetermined refrigerant temperature, laundry humidity or process air temperature.

[0017] A drying progress status may include the temperature of process air for example at drum exit or a humidity value of the laundry to be dried for example detected by a humidity sensor of the treatment apparatus.

[0018] A user selected variable, i.e. a user selection, may be for example a selected cycle, a selected cycle option or drying program type (e.g. fast-drying or night operation (silent and slow mode)), a residual laundry humidity, final humidity or drying level (e.g. extra-dry or iron-aid, i.e. higher residual laundry humidity), a laundry amount (e.g. input by user, detected by a weight sensor of the treatment apparatus (e.g. laundry dryer)), or estimated by an appropriate algorithm, a laundry type (e.g. cotton, wool etc.), and/or an energy-saving option or a drying process time-saving option (e.g. eco-mode, rapid).

[0019] A working parameter of the laundry compartment or laundry drum may be a power consumption of a drum motor for driving the drum and/or a rotation speed of the drum motor. In particular a plurality of laundry parameters may be derived from the power consumption of the drum motor. For example the laundry amount or load and its humidity or loss of humidity may be concluded/estimated from the detected power consumption of the drum motor. E.g. when driving or rotating the drum with a large (i.e. high weight) laundry load, the power consumption for rotating the laundry drum is higher than for a less weighing laundry load. Further, when the humidity level of the laundry decreases during a drying process, the drum motor has a lower power consumption when agitating the (less weighing) laundry.

[0020] A working parameter of the process air fan may be a fan rotation speed, a fan motor power consumption and/or a fan flow rate.

[0021] A working parameter of an electric driving motor, for example a drum motor driving a laundry drum, a process air fan motor for driving process air through the process air circuit, may be the motor power supply and/or power consumption of the motor as described above, or the current, the voltage, the phase supplied to such motor, or a parameter calculated therefrom, such as the motor torque.

[0022] A working parameter of the compressor may be its power consumption, the compressor speed and/or a com-

pressor motor status (e.g. On/Off).

[0023] An environment parameter of the treatment apparatus may be the detected ambient temperature and additionally or alternatively the humidity of ambient air outside the treatment apparatus.

[0024] An operation parameter set of the fan unit may be modified or changed in dependency of any one of the above described input variables or in dependency of an arbitrary combination of two or more of the input variables. I.e. an operation parameter set may be modified in dependency of each input variable independently from the other input variable(s).

[0025] Preferably the end of a sub-sequence is determined in response to the detected or monitored input variable exceeding, reaching or undershooting a predefined threshold, a predefined amount of change of the detected or monitored input variable, a predefined temporal gradient of the detected or monitored input variable, or an arbitrary combination thereof. The specific cycle or program step end condition is determined and controlled by the control unit, such that the selected drying program may be closely adapted to requirements of a presently running program or cycle.

[0026] According to an embodiment modifying or changing an operation parameter set for operating the cooling fan unit comprises changing from a first predetermined fan unit profile to a second predetermined fan unit profile, wherein the first fan unit profile is different from the second fan unit profile. E.g. a first fan unit profile is executed in a (first) cycle step or sub-sequence of a running drying program cycle. The cycle step is terminated as described above, e.g. because a predetermined threshold value is reached, i.e. a following (second) cycle step is started with a second fan unit profile different to the first.

[0027] For example an executed fan unit control profile may be a time behavior or time pattern, i.e. a profile over time, which is applied during the sub-sequence of the drying program until the monitored input variable reaches a predetermined sub-sequence end condition which terminates the sub-sequence. Preferably the predetermined fan unit (time) profile includes one or more of the following: a predetermined fan unit speed or conveyance capacity profile (e.g. an individual speed profile over time), a predetermined fan unit On/Off-time profile (e.g. a predetermined activation profile over time like 20 sec. On / 5 sec. Off - either periodic or non-periodic), and a predetermined fan unit On/Off duty cycle ratio, i.e. the ratio between On-time and Off-time of the fan unit.

[0028] Preferably an operation parameter set of the cooling fan unit provides an operation profile for switching the fan On and Off over time, i.e. a fan unit On/Off profile. As described above, detected input variables may be a working parameter of the treatment apparatus (e.g. drum motor speed, power consumption of the apparatus), a machine alarm or a (humidity) status of the laundry dried in the apparatus. If for example the power consumption of the treatment apparatus (i.e. the detected input variable) increases during a drying cycle above a predetermined threshold value the executed sub-sequence is terminated. In the following sub-sequence or cycle step an operation profile for the fan unit is selected (i.e. applied) by the control unit which increases the cooling power or conveying capacity of the fan unit. For example by providing an operation profile having longer operating phases between non-operating phases of the fan unit, i.e. by increasing a duty cycle ratio of the fan unit.

[0029] At least one of the working parameters and the status parameters may be detected by an associated sensor dedicated to the working parameter or status parameter to be detected, wherein the sensor signal is processed by a sensor unit. Examples for a sensor may be: a weight sensor for detecting a laundry amount or load, a temperature sensor for detecting a temperature of the treatment apparatus, in particular a starting temperature of the heat pump, a humidity sensor for detecting a laundry humidity in the laundry compartment. The sensor unit may be implemented or partially implemented in or by the control unit of the treatment apparatus.

[0030] According to an embodiment the control unit is adapted to derive at least one of the above mentioned working parameters and status parameters by monitoring a sensor signal (or signals) and/or a component status over time. For example as described above the laundry load or loss of humidity may be derived from the power consumption of the drum motor. Another example is deriving a laundry type by monitoring the progress of process air temperature and/or laundry humidity over time - possibly with knowledge of a laundry amount. For example wool absorbs more liquid than synthetic fibers. I.e. when heating process air to remove moisture from a load of woolen articles more water has to be vaporized - in comparison to a load of synthetic fibers - such that the temperature of the process air does not rise as fast.

[0031] Preferably a look-up table is implemented in the control unit, wherein the look-up table provides for each program cycle and for each sub-sequence of the program cycle (i) a corresponding operation parameter set for operating the cooling fan unit, or (ii) a reference to a corresponding operation parameter set for operating the cooling fan unit. A reference may be a location in a memory (of the control unit) where a corresponding operation parameter set is stored. Some of the operation parameter sets may be identical or the reference may point to the same memory location.

[0032] The method further comprises: changing an operation parameter set of the cooling fan unit in dependency of the detected end of a program sub-sequence, i.e. in dependency of at least one detected or monitored first input variable, as described above and additionally modifying or changing such a determined operation parameter set of the cooling fan unit in dependency of a second input variable, wherein the type of the second input variable is different of the type of the first input variable. For example the humidity level and the drum motor speed of the laundry load are the detected first and second input variables. E.g. when a predefined humidity level (end condition) is reached during a sub-sequence,

the sub-sequence is terminated and a predefined operation parameter set, e.g. ON/Off temperature set, is selected and applied to the fan unit for the following sub-sequence. Subsequently, i.e. during the executed sub-sequence or cycle step, the selected fan unit operation parameter set (ON/Off temperature set) is modified in dependency of the second input variable, e.g. the drum motor speed.

5 **[0033]** For example (a range of) the drum motor speed (input variable), e.g. motor speed < 2000 rpm, is related to a specific On/Off temperature set (fan unit operation parameter set), defining at which temperature the fan unit is switched-on and switched-Off (e.g. 58°C / 56°C). The higher the drum motor speed the lower the On/Off temperature set, i.e. other ranges of drum motor speed are related to other On/Off temperature sets for the fan unit. Thus the operation parameter settings of the fan unit may be individually adapted to the specific state or condition of a presently executed drying cycle (step). For example the temperature may be detected at any place in the treatment apparatus, e.g. at the heat pump system or laundry drum.

10 **[0034]** Preferably the control unit receives and processes the at least one input variable and is adapted to modify the operating parameter set of the cooling fan unit in response to the receiving and processing of the input variable. In case of repeatedly receiving one or more of the input variables, preferably the operating parameter set is changed only in response of a change in the input variable status or level. For example when the input variable changes from one predefined level range to another predefined level range (e.g. using thresholds for the variables).

15 **[0035]** Preferably the second input variable is at least one of the following input variables, which have been described in part above: a user selectable input variable, a machine alarm status parameter (e.g. overheat alarm, electric failure alarm etc.), a working parameter of the laundry drum, a working parameter of a process air fan, a working parameter of an electric driving motor, a working parameter of the compressor, a drying progress status parameter or a status parameter of the laundry to be dried, an environment parameter of the treatment apparatus environment, and a working parameter of the heat pump system. A working parameter of heat pump system is for example a temperature of the refrigerant, in particular the refrigerant temperature at one of the heat exchangers, at the compressor outlet or at the condenser outlet.

20 **[0036]** After terminating a sub-sequence or cycle step and starting a following cycle step as described above in dependency of a first input variable, it is preferred that for a predefined first range of the first input variable the operation parameter set of the cooling unit may be changed in dependency of the second input variable being in a first predefined range or being above or below a first predefined threshold, wherein for a predefined second range of the first input variable the operation parameter set of the cooling unit may be changed in dependency of the second input variable being in a second predefined range or being above or below a second predefined threshold. A general example comprising first and second threshold values (Thresholds 1 and 2) is depicted in the following Table 1:

Table 1: General example

Input Range	fan unit operation parameter set activated
Input < Threshold 1	fan unit operation parameter set 1
Threshold 1 < Input < Threshold 2	fan unit operation parameter set 2
Input > Threshold 2	fan unit operation parameter set 3

35 **[0037]** A specific example or application of the general example is shown in Table 2:

Table 2: Specific example

Drum motor speed (connected to fan unit)	fan unit On/Off temperature
Speed < 2000 rpm	58°C / 56°C
2000 rpm < speed < 2800 rpm	54°C / 53°C
Speed > 2800 rpm	51°C / 50°C

40 **[0038]** As shown in Table 2 the first input variable is the drum motor speed, wherein the second input variable is a temperature of a heat pump system temperature or refrigerant temperature. The applied fan unit On/Off temperature (in column 2) is selected in dependency of the drum motor speed (in column 1) - i.e. the higher the drum motor speed the lower the On/Off switching temperature to respond in time to a faster temperature rise of the compressor at higher drum motor speeds.

50 **[0039]** Preferably a look-up table, e.g. like shown in the example of Table 2, is implemented in the control unit and the operation parameter set to be selected is retrieved from the look-up table in dependency of the respective value or value range of the input variable.

[0040] According to an embodiment a further look-up table may be implemented in the control unit and the second input variable to be selected is retrieved from the further look-up table in dependency of the first input variable, wherein the first and second input variables govern the operation of the fan unit as described above and below. For example the first input variable may be the drum motor speed as shown above, the process air blower speed or the drum rotation speed, wherein the second input variable is a threshold temperature or temperature range of a heat pump system temperature or refrigerant temperature.

[0041] According to an embodiment the selection of the operation parameter set or the modification of the operation parameter set during a sub-sequence or cycle step may be made in dependency of a function in which the first input variable and the second input variable are used as function variables.

[0042] The following exemplary equations [1] and [2] show how a fan unit On/Off temperature may be calculated in dependency of the drum motor speed, wherein during an executed drying cycle the detected temperature, e.g. of the heat pump system, defines whether the fan unit is switched On or Off.

$$\text{Fan unit switch-ON temperature (}^\circ\text{C)} = 80 - \text{Drum Motor speed (rpm)} / 100 \quad [1]$$

$$\text{Fan unit switch-OFF temperature (}^\circ\text{C)} = 78 - \text{Drum Motor speed (rpm)} / 100 \quad [2]$$

[0043] I.e. corresponding to the example shown in Table 2 the drum motor speed is the first input variable and a temperature of e.g. the heat pump system is the second input variable, wherein the operation parameter set (switch-On / switch-Off temperature set) is set in dependency of the first input variable. In contrast to the example shown in Table 2, equations [1] and [2] provide a continuous adjustment of the fan unit switch-On / switch-Off temperature.

Table 3: Continuous adjustment of fan unit switch-On/-Off temperature in dependency of detected drum motor speed

drum motor [rpm]	fan unit switch-On temp. [°C]	fan unit switch-Off temp. [°C]
2000	60	58
2100	59	57
2200	58	56
....
2700	53	51
2800	52	50
2900	51	49
3000	50	48

[0044] According to claim 14 it is provided a heat pump laundry dryer or heat pump washing machine having drying function, wherein the laundry dryer or washing machine comprises:

- a control unit controlling the operation of the laundry dryer or washing machine,
 - a laundry drum for treating laundry using process air,
 - a process air circuit for circulating the process air,
 - a heat pump system having a refrigerant loop, in which the refrigerant fluid is circulated through a first and a second heat exchanger,
 - a compressor for circulating the refrigerant fluid through the refrigerant loop, and
 - a cooling fan unit for cooling the compressor, and
 - a sensor unit;
- wherein at least one of the working parameters and the status parameters is detected by an associated sensor dedicated to the working parameter or status parameter to be detected,
- wherein the sensor unit is adapted to process the sensor signal, and
- wherein the control unit is adapted to control the operation of the laundry dryer or of the washing machine according to the method described above.

[0045] Any of the above described features and elements of the method of operating a treatment apparatus may be

combined in any arbitrary combination and may be implemented in a heat pump laundry dryer or heat pump washing machine having drying function as described above.

[0046] Reference is made in detail to preferred embodiments of the invention, examples of which are illustrated in the accompanying figures, which show:

- 5
 Fig. 1 a schematic view of a laundry treatment apparatus having a heat pump system,
 Fig. 2 a schematic block diagram of components of the apparatus of Fig. 1,
 10 Fig. 3a-c schematic block diagrams of different relations between input variables and fan unit operation parameter settings,
 Fig. 4 a flow chart of how a user selection may modify fan unit parameter settings,
 15 Fig. 5 a flow chart showing an example of modifying fan unit parameter settings as given in Table 2,
 Fig. 6 a diagram showing the modification of fan unit parameter settings in dependency of drum motor speed over time as depicted in Fig. 5, and
 20 Fig. 7 a flow chart of how fan unit parameter settings may be modified during a drying cycle,

[0047] Fig. 1 depicts in a schematic representation a laundry treatment apparatus 2 which in this embodiment is a heat pump tumble dryer. The tumble dryer comprises a heat pump system 4, including in a closed refrigerant loop 6 in this order of refrigerant flow B: a first heat exchanger 10 acting as evaporator for evaporating the refrigerant and cooling
 25 process air, a compressor 14, a second heat exchanger 12 acting as condenser for cooling the refrigerant and heating the process air, and an expansion device 16 from where the refrigerant is returned to the first heat exchanger 10. Together with the refrigerant pipes connecting the components of the heat pump system 4 in series, the heat pump system 4 forms a refrigerant loop 6 through which the refrigerant is circulated by the compressor 14 as indicated by arrow B. If the refrigerant in the heat pump system 4 is operated in the transcritical or totally supercritical state, the first and second
 30 heat exchanger 10, 12 can act as gas heater and gas cooler, respectively.

[0048] The expansion device 16 is a controllable valve that operates under the control of a control unit 30 (Fig. 2) to adapt the flow resistance for the refrigerant in dependency of operating states of the heat pump system 4. In an embodiment the expansion device 16 may be a fixed, non-controllable device like a capillary tube.

[0049] The process air flow within the treatment apparatus 2 is guided through a compartment 18 of the treatment apparatus 2, i.e. through a compartment 18 for receiving articles to be treated, e.g. a drum 18. The articles to be treated are textiles, laundry 19, clothes, shoes or the like. In the embodiments here these are preferably textiles, laundry or clothes. The process air flow is indicated by arrows A in Fig. 1 and is driven by a process air blower 8 or fan. The process air channel 20 guides the process air flow A outside the drum 18 and includes different sections, including the section forming the battery channel 20a in which the first and second heat exchangers 10, 12 are arranged. The process air
 35 exiting the second heat exchanger 12 flows into a rear channel 20b in which the process air blower 8 is arranged. The air conveyed by blower 8 is guided upward in a rising channel 20c to the backside of the drum 18. The air exiting the drum 18 through the drum outlet (which is the loading opening of the drum) is filtered by a fluff filter 22 arranged close to the drum outlet in or at the channel 20.

[0050] When the heat pump system 4 is operating, the first heat exchanger 10 transfers heat from process air A to the refrigerant. By cooling the process air to lower temperatures, humidity from the process air condenses at the first heat exchanger 10, is collected there and drained to a condensate collector 26. The process air which is cooled and dehumidified after passing the first heat exchanger 10 passes subsequently through the second heat exchanger 12 where heat is transferred from the refrigerant to the process air. The process air is sucked from exchanger 12 by the blower 8 and is driven into the drum 18 where it heats up the laundry 19 and receives the humidity therefrom. The
 45 process air exits the drum 18 and is guided in front channel 20d back to the first heat exchanger 10. The main components of the heat pump system 4 are arranged in a base section 5 or basement of the dryer 2.

[0051] A cooling fan unit 24 or blower unit is arranged close to the compressor 14 for blowing cooling air C towards the compressor to remove heat from the compressor 14, i.e. from the heat pump system 4, during a drying operation. The cooling air flow C, which is an ambient air flow in the embodiments, is actively driven by the cooling fan unit 24 and is taking heat from (the surface of) the compressor 14. The fan unit 24 comprises a blower or fan 36 which is driven by a fan motor 34 controlled by the control unit 30 of the dryer 2. By transferring heat from the compressor 14, during a
 55 steady state of operation of the heat pump system 4, thermodynamic balance is achieved between the closed loops of the process air loop and refrigerant loop 6. Thereby the electrical power consumed by the compressor 14 which is not

transformed to work power by compressing the refrigerant is removed from the heat pump system 4, i.e. heat power of the compressor is balanced in the - under ideal consideration - closed loops of refrigerant and process air. This means, in the steady state of the heat pump system 4 in which maximum or nearly maximum operation condition or efficiency is achieved after the warm-up period, the heat deposited by the compressor 14 in the refrigerant loop 6 is balanced by the cooling fan unit 24 to prevent overheating. After starting the dryer 2 from a cold or ambient state the heat pump system 4 runs through a warm-up phase before reaching the steady state (i.e. normal or balanced mode after the warm-up period). As the heat pump system operation status changes (depending mainly on the refrigerant temperature) in the warm-up phase, the conditions for optimizing cooling requirement over time changes. The present invention provides a solution for optimizing cooling over time.

[0052] Fig. 2 shows a schematic block diagram of components of the dryer of Fig. 1 illustrating the control of the dryer components. The control unit 30 is adapted to control the operation of the components of the dryer 2, like a drum motor 32, the compressor 14, the valve 16 (optionally) and the fan motor, according to the selected program. Via an input panel 38 a user may select a drying program or cycle, e.g. fast, economy, iron-aid. Optionally further inputs may be made, e.g. residue humidity, laundry amount or laundry type. Further, the control unit 30 is adapted to control the fan unit 24 such that after a warm-up period a steady state of the heat pump system is maintained by operating the fan unit 24 for example as described below.

[0053] Depending on one or more input variables, which may be for example a user selection (e.g. a selected cycle), a working parameter of the drum motor (e.g. power consumption, motor speed), or a temperature (e.g. detected via temperature sensor 28 at condenser outlet), operation parameter settings of the fan unit 24 may be modified or changed by the control unit 30 as schematically shown in Fig. 3a. Operation parameter of the fan unit 24 may be a switch-On/Off temperature set, a cooling fan rotation speed, an On/Off activation duty ratio, an On/Off time profile (e.g. 10 sec. On, 5 sec. Off).

[0054] Fig. 3a shows an example for modifying an operation parameter set of the fan unit 24: In a first step an input variable x is detected or monitored by the control unit 30 at the beginning or before starting a drying program or cycle, e.g. the weight of laundry loaded in the drum 18. For example by means of a weight sensor or by a user input via input panel 38 (e.g. low/middle/high load). For each input variable (or range of input variables), i.e. the laundry weight, the control unit 30 is adapted to control the fan unit 24 to execute a predetermined fan unit control profile - e.g. a profile having a predefined On/Off activation profile and/or a predefined fan rotation speed profile. For example a look-up table is implemented in the control unit 30 which relates an input value or a range of input values to a specific fan unit control profile.

[0055] The predetermined control profile may be executed during the (remainder) of the drying program cycle or during a predetermined cycle step (cf. Fig. 4). I.e. the input variable x is detected once (at a start of a drying program) and determines the operation parameter set for the remainder of the drying cycle (or a step thereof). Alternatively the input variable x is detected repeatedly, e.g. permanently in real-time, and the control unit 30 is adapted to calculate an operation parameter set $f(x)$ in dependency of the detected input variable x repeatedly throughout a drying cycle. I.e. the operation of the fan unit 24 may be closely adapted to specific requirements of a presently executed drying program or cycle.

[0056] Fig. 3b shows another example for modifying an operation parameter set of the fan unit 24: In dependency of a detected or monitored first input variable x and second input variable y the control unit 30 is adapted to determine or calculate a corresponding operation parameter set $f(x, y)$ in dependency of both input variables x, y . The control unit 30 may retrieve the operation parameter set $f(x, y)$ from a look-up table (e.g. Table 2 or 3) or may calculate a corresponding operation parameter set from a predetermined function (e.g. equations [1] and [2]). A look-up table is preferred when relating a plurality of input values (or ranges thereof) to one specific operation parameter set as shown in Table 2. Calculating an operation parameter set is preferred when at least one input value is detected in real-time.

[0057] Fig. 3c shows a further example for modifying an operation parameter set of the fan unit 24: In dependency of a first input variable x a second input variable $g(x)$ to be detected is selected. For example a look-up table is implemented in the control unit which defines which second input variable is to be selected in dependency of the first input variable. In a next step the operation parameter set $f(x, g(x))$ is determined by the control unit 30 in dependency of the first and second input variable. For example by means of a further look-up table implemented in the control unit 30 or by providing a function or equation for calculating an operation parameter set for each detected first and second input value as described above.

[0058] Fig. 4 shows an exemplary flow chart of how a user selection modifies fan unit parameter settings. Different fan unit operation parameter sets 1..6 are selected for each drying cycle 1..4, each drying cycle plus option 1..2 (e.g. economy, night) and each drying cycle plus final humidity 1..2 (e.g. iron aid). For example a user selects drying cycle or program number 4 and selects additionally final humidity number 2, e.g. a high final humidity (iron-aid). Then the control unit 30 is adapted to select cooling fan parameter set 6 and correspondingly controls the fan unit 24.

[0059] Fig. 5 shows a flow chart illustrating how fan unit operation parameter settings may be modified as described above in the example of Table 2. I.e. the look-up table as shown in Table 2 is implemented in the control unit 30 to determine operation parameter settings in dependency of two input variables. The first input variable is the drum motor

speed and the second input variable is the temperature at the condenser exit detected by the temperature sensor 28. In dependency of the value of the drum motor speed, i.e. of a working parameter of the drum motor 32, a related fan unit On/Off temperature is selected by the control unit 30. This parameter set defines the temperatures at which the fan unit 24 is switched-On and switched-Off, respectively, while the temperature of the refrigerant at the condenser exit is detected or monitored repeatedly, e.g. every second. Thus the operation parameter may be adapted continuously to the requirements of the presently executed drying cycle.

[0060] Fig. 6 depicts a diagram illustrating the modification of fan unit parameter settings over time in dependency of the drum motor speed as shown in the example of Table 2 and Fig. 5, respectively.

[0061] Fig. 7 shows a flow chart illustrating how fan parameter settings are modified during a drying cycle or program. The drying cycle comprises a plurality of sub-sequences, program steps or cycle steps, i.e. each cycle step is part of the corresponding drying cycle or program. The duration or end of a cycle step or sub-sequence is determined by an end condition of an input variable which is detected during the cycle step. Every cycle step may be dependent on different parameters or input variables of each control system, for example drum movement speed or sequence and condensate pump activation mode (On/Off). Each cycle step may be terminated when certain predetermined control conditions or cycle end conditions are verified, for example: time is elapsed, laundry humidity degree is reached, and/or condenser exit temperature is reached. In other words by verifying the predetermined control or end conditions the duration or length of a cycle step is determined. I.e. for control conditions concerning e.g. laundry humidity or temperature thresholds the duration of cycle steps may vary in dependency of the type of laundry and laundry load. Thus the operation of the fan unit, i.e. the cooling power, can be closely adapted to the specific requirements of laundry to be dried.

[0062] As shown in the exemplary drying cycle of Fig. 7, with selection of the drying program (i.e. user selected input variable) a first operation parameter set 1 is selected and applied by the control unit to the cooling fan unit. During the first cycle step for example a predetermined On/Off profile as described above is applied to the fan unit 24. Alternatively or additionally the selected operation parameter set 1 may be dependent on the condenser exit temperature, e.g. the operation parameter set 1 comprises a threshold temperature or an On/Off temperature set as described above, which defines when the fan unit is switched On and Off.

[0063] The end or terminating condition for the first cycle step 1 is the condenser exit temperature of the refrigerant reaching a predetermined threshold temperature at the condenser exit, e.g. 45°C. When this condition is verified the first cycle step 1 is terminated and a second cycle step 2 is started, wherein a second operation parameter set 2 is selected and applied to the fan unit 24. The second parameter set 2 is for example dependent on an input variable different to the input variable(s) of the first cycle step 1, e.g. the second input variable is the time elapsed since cycle step 2 is started which is detected by a counter implemented by the control unit. The end condition for the second cycle step 2 is in this example an elapsed time of 30 minutes since cycle step 2 started. When this end condition is verified by the control unit the second cycle step 2 is terminated and a third cycle step 3 is started.

[0064] Similarly as described above with respect to the first and second cycle steps, a third parameter set 3 is selected and applied to the fan unit 24 with starting the third cycle step 3. The third parameter set 3 may be dependent on any of the above described input variables, wherein in this example the end condition of the third cycle step is determined by reaching a predetermined threshold value of laundry humidity, e.g. 12%. I.e. when this end condition is verified, e.g. by means of a humidity sensor of the treatment apparatus 2, the third cycle step 3 is terminated and a final fourth cycle step 4 is started.

[0065] A fourth operation parameter set 4 is selected by the control unit 30 for the fourth cycle step 4. Any of the above described input variables and operation parameter settings may be used for the fourth cycle step 4. For example a predetermined On/Off time profile, an On/Off temperature set defining when the fan unit 24 is switched On and Off, a threshold value for the power consumption of the compressor 14 or a humidity of the laundry or process air. In this example the end condition for terminating cycle step 4 is reaching a laundry humidity of 0 %, i.e. dry laundry. When for example a drying program is selected and executed with the option 'iron-aid', i.e. a higher final laundry humidity, the terminating condition for the last cycle step could be reaching a final humidity of 10 %. The end condition of the fourth cycle step terminates the drying program or drying cycle.

Reference Numeral List

[0066]

- 2 heat pump tumble dryer
- 4 heat pump system
- 5 base section
- 6 refrigerant loop
- 8 blower
- 10 first heat exchanger (evaporator)

- 12 second heat exchanger (condenser)
- 14 compressor
- 16 expansion device
- 18 drum (laundry compartment)
- 5 19 laundry
- 20 process air channel
- 20a battery channel
- 20b rear channel
- 20c rising channel
- 10 20d front channel
- 22 fluff filter
- 24 cooling fan unit
- 26 condensate collector
- 28 temperature sensor
- 15 30 control unit
- 32 drum motor
- 34 fan motor
- 36 fan
- 38 input panel
- 20
- A process air flow
- B refrigerant flow
- C cooling air flow

25

Claims

1. Method of operating a heat pump laundry dryer or a heat pump washing machine having drying function, wherein the laundry dryer or washing machine comprises:

30

a control unit (30) controlling the operation of the laundry dryer or washing machine,
a laundry drum (18) for treating laundry using process air,
a process air circuit for circulating the process air,
a heat pump system (4) having a refrigerant loop, in which the refrigerant fluid is circulated through a first and
35 a second heat exchanger (10, 12),
a compressor (14) for circulating the refrigerant fluid through the refrigerant loop, and
a cooling fan unit (24) for cooling the compressor (14),
wherein the method comprises: detecting or monitoring one or a plurality of input variables during a running
program cycle;
40 the method further comprises:

40

determining the end of a program sub-sequence by detecting or monitoring the one or the plurality of input
variables, and
modifying or changing an operation parameter set for operating the cooling fan unit upon determining the
45 end of the program sub-sequence,
wherein the one or the plurality of input variables is at least one of the following input variables:

45

a) a user selectable input variable, being one or more of:

50

a laundry type,
a drying program type,
a residual laundry humidity,
an energy-saving option,
a drying process time-saving option,
55 the laundry amount,
a final laundry humidity, and
a drying level;

55

EP 2 920 354 B1

b) a working parameter of the laundry drum (18), being one or more of:

- a power supply of a drum motor,
- a power consumption of a drum motor,
- a rotation speed of a drum motor,
- a voltage, current, or phase supplied to a drum motor,
- a motor torque of a drum motor, and
- a laundry parameter derived from the power consumption of a drum motor;

c) a working parameter of a process air fan (8), being one or more of:

- a process air fan rotation speed,
- a process air fan motor power supply,
- a power consumption,
- a process air fan flow rate, and
- a voltage, current, or phase supplied to a process air fan motor;

d) a working parameter of the heat pump system (4),

e) a working parameter of an electric driving motor (32), being one or more of:

- a motor power supply,
- a motor power consumption, and
- a voltage, current, or phase supplied to the motor;

f) a working parameter of the compressor (14), being one or more of:

- the compressor power consumption,
- the compressor speed, and
- the compressor motor status;

g) a working parameter of a liquid pump or condensate pump;

h) a humidity value of the laundry to be dried;

i) a status of a liquid or condensate level;

j) an environment parameter of the treatment apparatus environment; and

k) a machine alarm status parameter.

2. Method according to claim 1, wherein the or each of the plurality of program cycles each has a first sub-sequence and at least a second sub-sequence, wherein the first sub-sequence has a first operating set for operating the cooling fan unit (24) and the second sub-sequence has a second operating set for operating the cooling fan unit, and wherein the first and second operating sets are different from each other.

3. Method according to claim 1 or 2, wherein the end of a sub-sequence is determined in response to the detected or monitored input variable exceeding, reaching or undershooting a predefined threshold, exceeding, reaching or undershooting a predefined amount of change of the detected or monitored input variable, exceeding, reaching or undershooting a predefined temporal gradient of the detected or monitored input variable, or a combination thereof.

4. Method according to claim 1, 2, or 3, wherein a program cycle is one of a drying cycle, a laundry refreshment cycle, a laundry dry cleaning cycle, a laundry chemical processing cycle, a washing cycle, and an anti-wrinkle cycle.

5. Method according to any of the previous claims, wherein modifying or changing an operation parameter set for operating the cooling fan unit comprises changing from a first predetermined fan unit profile to a second predetermined fan unit profile, wherein the first fan unit profile is different from the second fan unit profile and each fan unit profile includes one or more of:

- a predetermined fan unit speed or conveyance capacity profile,
- a predetermined fan unit On/Off-time profile, and

a predetermined fan unit On/Off duty cycle ratio.

5 6. Method according to any of the previous claims, wherein at least one of the working parameters and the status parameters is detected by an associated sensor dedicated to the working parameter or status parameter to be detected, wherein the sensor signal is processed by a sensor unit (30).

7. Method according to any of the previous claims, wherein the control unit (30) is adapted to derive at least one of the working parameters and the status parameters by monitoring a sensor signal or a component status over time.

10 8. Method according to any of the previous claims, wherein a look-up table is implemented in the control unit (30), wherein the look-up table provides for each program cycle and for each sub-sequence of the program cycle

- a corresponding operation parameter set for operating the cooling fan unit (24), or
- a reference to a corresponding operation parameter set for operating the cooling fan unit.

15 9. Method according to any of the previous claims, wherein the method further comprises:

20 changing an operation parameter set of the cooling fan unit (24) in dependency of the detected end of a program sub-sequence dependent on at least one first input variable according to any of the previous claims, and additionally modifying or changing such determined operation parameter set of the cooling fan unit (24) in dependency of a second input variable, wherein the type of the second input variable is different from the type of the first input variable.

25 10. Method according to claim 9, wherein the second input variable is at least one of the following input variables:

- a user selectable input variable,
- a machine alarm status parameter,
- a working parameter of the laundry drum (18),
- a working parameter of a process air fan (8),
- 30 a working parameter of an electric driving motor (32),
- a working parameter of the compressor (14),
- a drying progress status parameter or a status parameter of the laundry to be dried,
- an environment parameter of the treatment apparatus environment, and
- a working parameter of the heat pump system (4).

35 11. Method according to claim 9 or 10, wherein for a predefined first range of the first input variable the operation parameter set of the cooling unit (24) is changed in dependency of the second input variable being in a first predefined range or being above or below a first predefined threshold, and wherein for a predefined second range of the first input variable the operation parameter set of the cooling unit (24) is changed in dependency of the second input variable being in a second predefined range or being above or below a second predefined threshold

40 12. Method according to claim 9, 10 or 11, wherein the first input variable is the drum motor speed, the process air blower speed or the drum rotation speed, and wherein the second variable is a threshold temperature or temperature range of a heat pump system temperature or refrigerant temperature.

45 13. Method according to any of claims 9 to 12, wherein the selection of the operation parameter set or the modification of the operation parameter set is made in dependency of a function in which the second input variable is used as function variable.

50 14. Heat pump laundry dryer or heat pump washing machine having drying function, wherein the laundry dryer or washing machine comprises:

- 55 a control unit (30) controlling the operation of the laundry dryer or washing machine,
- a laundry drum (18) for treating laundry using process air,
- a process air circuit for circulating the process air,
- a heat pump system (4) having a refrigerant loop (6), in which the refrigerant fluid is circulated through a first

and a second heat exchanger (10, 12),
 a compressor (14) for circulating the refrigerant fluid through the refrigerant loop (6), and
 a cooling fan unit (24) for cooling the compressor (14), and
 a sensor unit;

wherein at least one of the working parameters and the status parameters is detected by an associated sensor
 dedicated to the working parameter or status parameter to be detected,
 wherein the sensor unit is adapted to process the sensor signal, and
 wherein the control unit (30) is adapted to control the operation of the laundry dryer or of the washing machine
 according to any of the previous claims 1-13.

Patentansprüche

1. Verfahren zum Betreiben eines Wärmepumpen-Wäschetrockners oder einer Wärmepumpen-Waschmaschine, die
 eine Trocknungsfunktion aufweist, wobei der Wäschetrockner oder die Waschmaschine Folgendes umfasst:

eine Steuereinheit (30), die den Betrieb des Wäschetrockners oder der Waschmaschine steuert,
 eine Wäschetrommel (18) zum Behandeln von Wäsche unter Verwendung von Prozessluft,
 einen Prozessluftkreislauf, um die Prozessluft umzuwälzen,
 ein Wärmepumpensystem (4), das einen Kühlmittelkreislauf aufweist, in dem das Kühlmittelfluid durch einen
 ersten und einen zweiten Wärmetauscher (10, 12) umgewälzt wird,
 einen Kompressor (14), um das Kühlmittelfluid durch den Kühlmittelkreislauf umzuwälzen,
 und
 eine Kühlgebläseeinheit (24) zum Kühlen des Kompressors (14),
 wobei das Verfahren den folgenden Schritt umfasst: Detektieren oder Überwachen einer oder mehrerer Ein-
 gangsvARIABLEN während eines laufenden Programmzyklus;
 wobei das Verfahren ferner die folgenden Schritte umfasst:

Ermitteln des Endes einer Programm-Teilsequenz durch Detektieren oder Überwachen der einen oder der
 mehreren EingangsvARIABLEN, und
 Modifizieren oder Ändern eines Betriebsparametersatzes zum Betreiben der Kühlgebläseeinheit beim Er-
 mitteln des Endes der Programm-Teilsequenz,
 wobei die eine oder die mehreren EingangsvARIABLEN wenigstens eine der folgenden EingangsvARIABLEN ist:

- a) eine durch einen Benutzer auswählbare EingangsvARIABLE, die eine oder mehrere der folgenden
 Variablen ist:

ein Wäschetyp,
 ein Trocknungsprogrammtyp,
 eine verbleibende Wäscheuchtigkeit,
 eine Energiesparoption,
 eine Trocknungsverfahren-Zeitsparoption die Wäschemenge,
 eine endgültige Wäscheuchtigkeit, und
 ein Trocknungsgrad;

- b) ein Arbeitsparameter der Wäschetrommel (18), der einer oder mehrere der folgenden Parameter
 sein kann:

eine Energiezufuhr eines Trommelmotors,
 ein Energieverbrauch eines Trommelmotors,
 eine Drehzahl eines Trommelmotors,
 eine Spannung, ein Strom oder eine Phase, die einem Trommelmotor zugeführt wird,
 ein Motordrehmoment eines Trommelmotors, und
 ein Wäscheparameter, der aus dem Energieverbrauch eines Trommelmotors abgeleitet wird;

- c) ein Arbeitsparameter eines Prozessluftgebläses (8), der einer oder mehrere der folgenden Parameter
 sein kann:

EP 2 920 354 B1

eine Prozessluft-Gebläsedrehzahl,
eine Energiezufuhr für den Prozessluft-Gebläsemotor,
ein Energieverbrauch,
einen Prozessluft-Gebläsedurchfluss, und
eine Spannung, ein Strom oder eine Phase, die einem Prozessluft-Gebläsemotor zugeführt wird;

d) ein Arbeitsparameter des Wärmepumpensystems (4),
e) ein Arbeitsparameter eines elektrischen Antriebsmotors (32), der einer oder mehrere der folgenden Parameter sein kann:

eine Motor-Energiezufuhr,
ein Motor-Energieverbrauch, und
eine Spannung, ein Strom oder eine Phase, die dem Motor zugeführt wird;

f) ein Arbeitsparameter des Kompressors (14), der einer oder mehrere der folgenden Parameter sein kann:

der Kompressor-Energieverbrauch,
die Kompressor-Drehzahl, und
der Kompressormotor-Status;

g) ein Arbeitsparameter einer Flüssigkeitspumpe oder einer Kondensatpumpe;
h) ein Feuchtigkeitswert der zu trocknenden Wäsche;
i) ein Status eines Flüssigkeits- oder Kondensatfüllstands;
j) ein Umgebungsparameter der Umgebung der Behandlungsvorrichtung; und
k) ein Maschinenalarm-Statusparameter.

2. Verfahren nach Anspruch 1, wobei der eine oder jeder der mehreren Programmzyklen eine erste Teilsequenz und wenigstens eine zweite Teilsequenz aufweist, wobei die erste Teilsequenz einen ersten Betriebssatz zum Betreiben der Kühlgebläseeinheit (24) aufweist und die zweite Teilsequenz einen zweiten Betriebssatz zum Betreiben der Kühlgebläseeinheit aufweist, und wobei sich der erste und der zweite Betriebssatz voneinander unterscheiden.

3. Verfahren nach Anspruch 1 oder 2, wobei das Ende einer Teilsequenz in Reaktion auf die detektierte oder überwachte Eingangsvariable ermittelt wird, wenn Folgendes eintritt:

Überschreiten, Erreichen oder Unterschreiten eines festgelegten Schwellenwerts;
Überschreiten, Erreichen oder Unterschreiten eines festgelegten Änderungsbetrags der detektierten oder überwachten Eingangsvariablen,
Überschreiten, Erreichen oder Unterschreiten eines festgelegten zeitlichen Gradienten der detektierten oder überwachten Eingangsvariablen, oder
eine Kombination davon.

4. Verfahren nach Anspruch 1, 2 oder 3, wobei ein Programmzyklus ein Trocknungszyklus, ein Wäscheauffrischzyklus, ein Wäsche-Trockenreinigungszyklus, ein chemischer Wäschebearbeitungszyklus, ein Waschzyklus oder ein Antiknitterzyklus ist.

5. Verfahren nach einem der vorhergehenden Ansprüche, wobei das Modifizieren oder Ändern eines Betriebsparametersatzes zum Betreiben der Kühlgebläseeinheit ein Wechseln von einem ersten festgelegten Gebläseeinheitsprofil zu einem zweiten festgelegten Gebläseeinheitsprofil umfasst, wobei sich das erste Gebläseeinheitsprofil von dem zweiten Gebläseeinheitsprofil unterscheidet und wobei jedes Gebläseeinheitsprofil einen oder mehrere der folgenden Parameter umfasst:

eine festgelegte Drehzahl der Gebläseeinheit oder ein Förderkapazitätsprofil,
ein festgelegtes Ein/Aus-Zeitprofil der Gebläseeinheit, und
ein festgelegtes Ein/Aus-Lastzyklusverhältnis der Gebläseeinheit.

6. Verfahren nach einem der vorhergehenden Ansprüche, wobei wenigstens einer der Arbeitsparameter und der Statusparameter durch einen zugehörigen Sensor detektiert wird, der dem Arbeitsparameter oder dem Statusparameter,

der detektiert werden soll, zugewiesen ist, wobei das Sensorsignal durch eine Sensoreinheit (30) verarbeitet wird.

7. Verfahren nach einem der vorhergehenden Ansprüche, wobei die Steuereinheit (30) ausgelegt ist, wenigstens einen der Arbeitsparameter und der Statusparameter durch Überwachen eines Sensorsignals oder eines Status einer Komponente in Abhängigkeit von der Zeit abzuleiten.

8. Verfahren nach einem der vorhergehenden Ansprüche, wobei eine Nachschlagetabelle in der Steuereinheit (30) enthalten ist, wobei die Nachschlagetabelle für jeden Programmzyklus und für jede Teilsequenz des Programmzyklus die folgenden Parameter bereitstellt:

- einen entsprechenden Betriebsparametersatz zum Betreiben der Kühlgebläseeinheit (24), oder
- einen Bezugswert für einen entsprechenden Betriebsparametersatz zum Betreiben der Kühlgebläseeinheit.

9. Verfahren nach einem der vorhergehenden Ansprüche, wobei das Verfahren ferner die folgenden Schritte umfasst:

Ändern eines Betriebsparametersatzes der Kühlgebläseeinheit (24) in Abhängigkeit von dem detektierten Ende einer Programm-Teilsequenz in Abhängigkeit von wenigstens einer ersten Eingangsvariablen nach einem der vorhergehenden Ansprüche, und zusätzlich das Modifizieren oder Ändern eines festgelegten Betriebsparametersatzes der Kühlgebläseeinheit (24) in Abhängigkeit von einer zweiten Eingangsvariablen, wobei sich der Typ der zweiten Eingangsvariablen von dem Typ der ersten Eingangsvariablen unterscheidet.

10. Verfahren nach Anspruch 9, wobei die zweite Eingangsvariable wenigstens eine der folgenden Eingangsvariablen ist:

- eine durch einen Benutzer auswählbare Eingangsvariable,
- ein Maschinenalarm-Statusparameter,
- ein Arbeitsparameter der Wäschetrommel (18),
- ein Arbeitsparameter eines Prozessluftgebläses (8),
- ein Arbeitsparameter eines elektrischen Antriebsmotors (32),
- ein Arbeitsparameter des Kompressors (14),
- ein Trocknungsfortschritt-Statusparameter oder ein Statusparameter der zu trocknenden Wäsche,
- ein Umgebungsparameter der Umgebung der Behandlungsvorrichtung, und
- ein Arbeitsparameter des Wärmepumpensystems (4).

11. Verfahren nach Anspruch 9 oder 10, bei für einen festgelegten ersten Bereich der ersten Eingangsvariablen der Betriebsparametersatz der Kühleinheit (24) in Abhängigkeit von der zweiten Eingangsvariablen, die in einem ersten festgelegten Bereich liegt oder die über oder unter einem ersten festgelegten Schwellenwert liegt, geändert wird, und wobei für einen festgelegten zweiten Bereich der ersten Eingangsvariablen der Betriebsparametersatz der Kühleinheit (24) in Abhängigkeit von der zweiten Eingangsvariablen, die in einem zweiten festgelegten Bereich liegt oder die über oder unter einem zweiten festgelegten Schwellenwert liegt, geändert wird.

12. Verfahren nach Anspruch 9, 10 oder 11, wobei die erste Eingangsvariable die Trommelmotordrehzahl, die Prozessluft-Lüfterdrehzahl oder die Trommeldrehzahl ist, und wobei die zweite Variable eine Schwellenwerttemperatur oder ein Temperaturbereich einer Wärmepumpen-Systemtemperatur oder einer Kühlmitteltemperatur ist.

13. Verfahren nach einem der Ansprüche 9 bis 12, wobei die Auswahl des Betriebsparametersatzes oder die Modifikation des Betriebsparametersatzes in Abhängigkeit von einer Funktion durchgeführt wird, in der die zweite Eingangsvariable als Funktionsvariable verwendet wird.

14. Wärmepumpen-Wäschetrockner oder Wärmepumpen-Waschmaschine, die eine Trocknungsfunktion aufweist, wobei der Wäschetrockner oder die Waschmaschine Folgendes umfasst:

- eine Steuereinheit (30), die den Betrieb des Wäschetrockners oder der Waschmaschine steuert,
- eine Wäschetrommel (18) zum Behandeln von Wäsche unter Verwendung von Prozessluft,
- einen Prozessluftkreislauf, um die Prozessluft umzuwälzen,
- ein Wärmepumpensystem (4), das einen Kühlmittelkreislauf (6) aufweist, in dem das Kühlmittelfluid durch einen ersten und einen zweiten Wärmetauscher (10, 12) umgewälzt wird,

einen Kompressor (14), um das Kühlmittelfluid durch den Kühlmittelkreislauf (6) umzuwälzen, und eine Kühlgebläseeinheit (24) zum Kühlen des Kompressors (14), und eine Sensoreinheit;

wobei wenigstens einer der Arbeitsparameter und der Statusparameter durch einen zugeordneten Sensor detektiert wird, der dem Arbeitsparameter oder dem Statusparameter, der detektiert werden soll, zugewiesen ist, wobei die Sensoreinheit ausgelegt ist, das Sensorsignal zu verarbeiten, und wobei die Steuereinheit (30) ausgelegt ist, den Betrieb des Wäschetrockners oder der Waschmaschine nach einem der vorhergehenden Ansprüche 1 - 13 zu steuern.

Revendications

1. Procédé permettant de faire fonctionner un sèche-linge à pompe à chaleur ou une machine à laver à pompe à chaleur dotée d'une fonction de séchage, le sèche-linge ou la machine à laver comprenant :

une unité de commande (30) commandant le fonctionnement du sèche-linge ou de la machine à laver, un tambour à linge (18) destiné à traiter du linge au moyen d'air de processus, un circuit d'air de processus destiné à faire circuler l'air de processus, un système de pompe à chaleur (4) doté d'une boucle de frigorigène, dans lequel le fluide frigorigène circule à travers un premier et un deuxième échangeur de chaleur (10, 12), un compresseur (14) destiné à faire circuler le fluide frigorigène à travers la boucle de frigorigène, et une unité ventilateur de refroidissement (24) destinée à refroidir le compresseur (14), le procédé comprenant : la détection ou la surveillance d'une ou d'une pluralité de variables d'entrée au cours d'un cycle de programme en cours d'exécution ; le procédé comprenant en outre :

la détermination de la fin d'une sous-séquence de programme par détection ou surveillance de la ou de la pluralité de variables d'entrée, et la modification ou le changement d'un jeu de paramètres de fonctionnement permettant le fonctionnement de l'unité ventilateur de refroidissement lors de la détermination de la fin de la sous-séquence de programme, la ou la pluralité de variables d'entrée consistant en au moins une des variables d'entrée suivantes :

- a) une variable d'entrée sélectionnable par l'utilisateur, consistant en un ou plusieurs éléments dans le groupe constitué par :

un type de linge,
un type de programme de séchage,
une humidité de linge résiduelle,
une option d'économie d'énergie,
une option d'économie de temps de processus de séchage,
une quantité de linge,
une humidité de linge finale, et
un niveau de séchage ;

- b) un paramètre de travail du tambour à linge (18), consistant en un ou plusieurs éléments dans le groupe constitué par :

une alimentation en énergie d'un moteur du tambour,
une consommation d'énergie d'un moteur du tambour,
une vitesse de rotation d'un moteur du tambour,
une tension, un courant ou une phase fournis à un moteur du tambour,
un couple moteur d'un moteur du tambour, et
un paramètre de linge déduit de la consommation d'énergie d'un moteur du tambour ;

- c) un paramètre de travail d'un ventilateur d'air de processus (8), consistant en un ou plusieurs éléments dans le groupe constitué par :

une vitesse de rotation du ventilateur d'air de processus,

EP 2 920 354 B1

une alimentation en énergie de moteur du ventilateur d'air de processus,
une consommation d'énergie,
un débit du ventilateur d'air de processus, et
une tension, un courant ou une phase fournis à un moteur du ventilateur d'air de processus ;

5

d) un paramètre de travail du système de pompe à chaleur (4),
e) un paramètre de travail d'un moteur d'entraînement électrique (32), consistant en un ou plusieurs éléments dans le groupe constitué par :

10

une alimentation en énergie du moteur,
une consommation d'énergie du moteur, et
une tension, un courant ou une phase fournis au moteur ;

15

f) un paramètre de travail du compresseur (14), consistant en un ou plusieurs éléments dans le groupe constitué par :

la consommation d'énergie du compresseur,
la vitesse du compresseur, et
l'état de moteur du compresseur ;

20

g) un paramètre de travail d'un pompe à liquide ou d'une pompe à condensat ;
h) une valeur d'humidité du linge à sécher ;
i) un état d'un niveau de liquide ou de condensat ;
j) un paramètre ambiant du milieu ambiant de l'appareil de traitement ; et
k) un paramètre d'état d'alarme de la machine.

25

2. Procédé selon la revendication 1, dans lequel le ou chacun de la pluralité de cycles de programme possède une première sous-séquence et au moins une deuxième sous-séquence, dans lequel la première sous-séquence possède un premier jeu de fonctionnement permettant le fonctionnement de l'unité ventilateur de refroidissement (24) et la deuxième sous-séquence possède un deuxième jeu de fonctionnement permettant le fonctionnement de l'unité ventilateur de refroidissement, et dans lequel les premier et deuxième jeux de fonctionnement sont différents l'un de l'autre.

30

3. Procédé selon la revendication 1 ou 2, dans lequel la fin d'une sous-séquence est déterminée dès que la variable d'entrée détectée ou surveillée dépasse, atteint ou ne parvient pas à un seuil prédéterminé, dépasse, atteint ou ne parvient pas à une quantité prédéfinie de changement de la variable d'entrée détectée ou surveillée, dépasse, atteint ou ne parvient pas à un gradient temporel prédéfini de la variable d'entrée détectée ou surveillée, ou une combinaison de ces éléments.

35

40

4. Procédé selon la revendication 1, 2 ou 3, dans lequel un cycle de programme consiste en l'un des cycles suivants : un cycle de séchage, un cycle de rafraîchissement de linge, un cycle de nettoyage à sec de linge, un cycle de traitement chimique de linge, un cycle de lavage et un cycle d'antifroissage.

45

5. Procédé selon l'une quelconque des revendications précédentes, dans lequel la modification ou le changement d'un jeu de paramètres de fonctionnement permettant le fonctionnement de l'unité ventilateur de refroidissement comprend le changement d'un premier profil prédéterminé d'unité ventilateur pour un deuxième profil prédéterminé d'unité ventilateur, le premier profil prédéterminé d'unité ventilateur étant différent du deuxième profil prédéterminé d'unité ventilateur et chaque profil d'unité ventilateur comportant :

50

un profil prédéterminé de vitesse ou de capacité d'acheminement d'unité ventilateur, et/ou
un profil prédéterminé de durée de marche/arrêt d'unité ventilateur, et/ou
un rapport prédéterminé de cycle de travail marche/arrêt d'unité ventilateur.

55

6. Procédé selon l'une quelconque des revendications précédentes, dans lequel au moins un des paramètres de travail et des paramètres d'état est détecté par un capteur associé dédié au paramètre de travail ou au paramètre d'état à détecter, le signal de capteur étant traité par une unité capteur (30).

EP 2 920 354 B1

7. Procédé selon l'une quelconque des revendications précédentes, dans lequel l'unité de commande (30) est adaptée à déduire au moins un des paramètres de travail et des paramètres d'état en surveillant dans le temps un signal de capteur ou un état de composant.
- 5 8. Procédé selon l'une quelconque des revendications précédentes, dans lequel une table de recherche est mise en œuvre dans l'unité de commande (30), la table de recherche fournissant, pour chaque cycle de programme et pour chaque sous-séquence du cycle de programme
- 10 - un jeu de paramètres de fonctionnement correspondant permettant le fonctionnement de l'unité ventilateur de refroidissement (24), ou
- une référence à un jeu de paramètres de fonctionnement correspondant permettant le fonctionnement de l'unité ventilateur de refroidissement.
- 15 9. Procédé selon l'une quelconque des revendications précédentes, lequel procédé comprend en outre :
- le changement d'un jeu de paramètres de fonctionnement de l'unité ventilateur de refroidissement (24) en fonction de la fin détectée d'une sous-séquence de programme dépendant d'au moins une première variable d'entrée selon l'une quelconque des revendications précédentes, et
la modification ou le changement supplémentaire de ce jeu de paramètres de fonctionnement déterminé de
20 l'unité ventilateur de refroidissement (24) en fonction d'une deuxième variable d'entrée,
le type de la deuxième variable d'entrée étant différent du type de la première variable d'entrée.
- 25 10. Procédé selon la revendication 9, dans lequel la deuxième variable d'entrée consiste en au moins une des variables d'entrée suivantes :
- une variable d'entrée sélectionnable par l'utilisateur,
un paramètre d'état d'alarme de la machine,
un paramètre de travail du tambour à linge (18),
un paramètre de travail d'un ventilateur d'air de processus (8),
30 un paramètre de travail d'un moteur d'entraînement électrique (32),
un paramètre de travail du compresseur (14),
un paramètre d'état d'avancement de séchage ou un paramètre d'état du linge à sécher,
un paramètre ambiant du milieu ambiant de l'appareil de traitement, et
un paramètre de travail du système de pompe à chaleur (4).
- 35 11. Procédé selon la revendication 9 ou 10, dans lequel, pour une première plage prédéfinie de la première variable d'entrée, le jeu de paramètres de fonctionnement de l'unité de refroidissement (24) est changé selon que la deuxième variable d'entrée s'inscrit dans une première plage prédéfinie ou est supérieure ou inférieure à un premier seuil prédéfini, et
40 dans lequel, pour une deuxième plage prédéfinie de la première variable d'entrée, le jeu de paramètres de fonctionnement de l'unité de refroidissement (24) est changé selon que la deuxième variable d'entrée s'inscrit dans une deuxième plage prédéfinie ou est supérieure ou inférieure à un deuxième seuil prédéfini.
- 45 12. Procédé selon la revendication 9, 10 ou 11, dans lequel la première variable d'entrée consiste en la vitesse de moteur du tambour, la vitesse de la soufflante d'air de processus ou la vitesse de rotation du tambour, et dans lequel la deuxième variable consiste en une température-seuil ou une plage de températures d'une température du système de pompe à chaleur ou d'une température de frigorigène.
- 50 13. Procédé selon l'une quelconque des revendications 9 à 12, dans lequel la sélection du jeu de paramètres de fonctionnement ou la modification du jeu de paramètres de fonctionnement s'effectue en fonction d'une fonction dans laquelle la deuxième variable d'entrée est utilisée comme variable de fonction.
- 55 14. Sèche-linge à pompe à chaleur ou machine à laver à pompe à chaleur dotée d'une fonction de séchage, le sèche-linge ou la machine à laver comprenant :
- une unité de commande (30) commandant le fonctionnement du sèche-linge ou de la machine à laver,
un tambour à linge (18) destiné à traiter du linge au moyen d'air de processus,
un circuit d'air de processus destiné à faire circuler l'air de processus,

EP 2 920 354 B1

un système de pompe à chaleur (4) doté d'une boucle de frigorigène (6), dans lequel le fluide frigorigène circule à travers un premier et un deuxième échangeur de chaleur (10, 12),

un compresseur (14) destiné à faire circuler le fluide frigorigène à travers la boucle de frigorigène (6), et
une unité ventilateur de refroidissement (24) destinée à refroidir le compresseur (14), et

5 une unité capteur ;

au moins un des paramètres de travail et des paramètres d'état étant détecté par un capteur associé dédié au paramètre de travail ou au paramètre d'état à détecter,

l'unité capteur étant adaptée à traiter le signal de capteur, et

10 l'unité de commande (30) étant adaptée à commander le fonctionnement du sèche-linge ou de la machine à laver selon l'une quelconque des revendications 1 à 13.

15

20

25

30

35

40

45

50

55

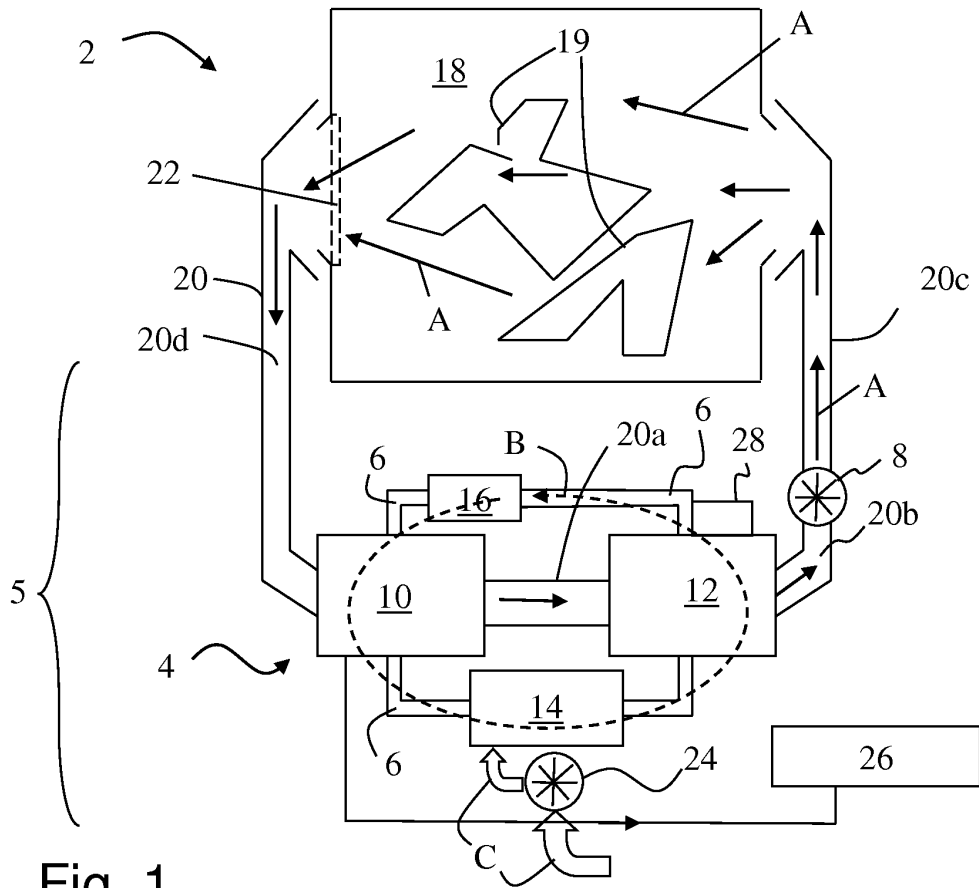

Fig. 1

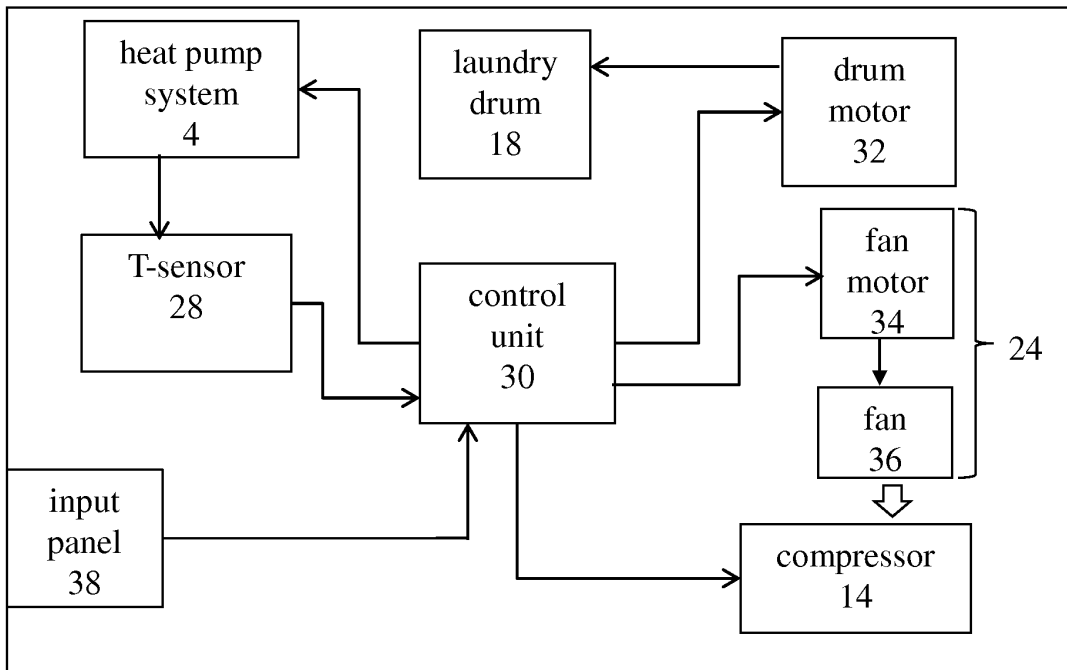

Fig. 2

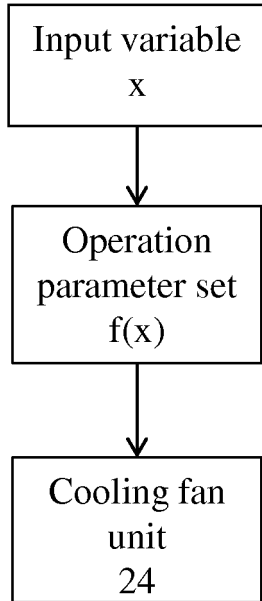

Fig. 3a

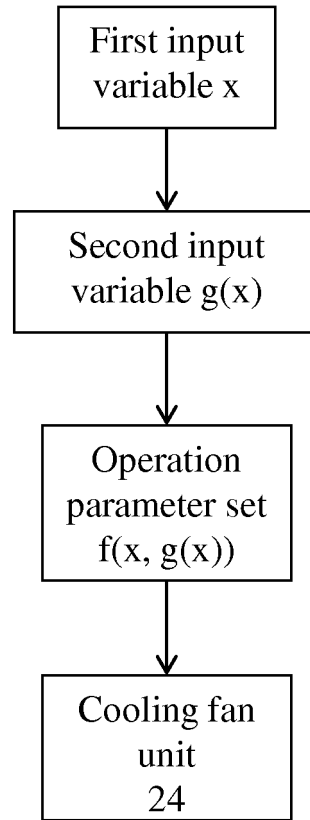

Fig. 3c

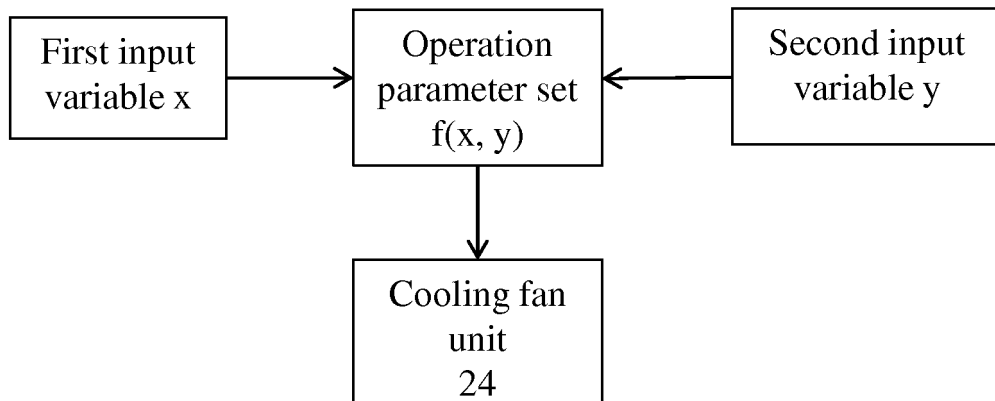

Fig. 3b

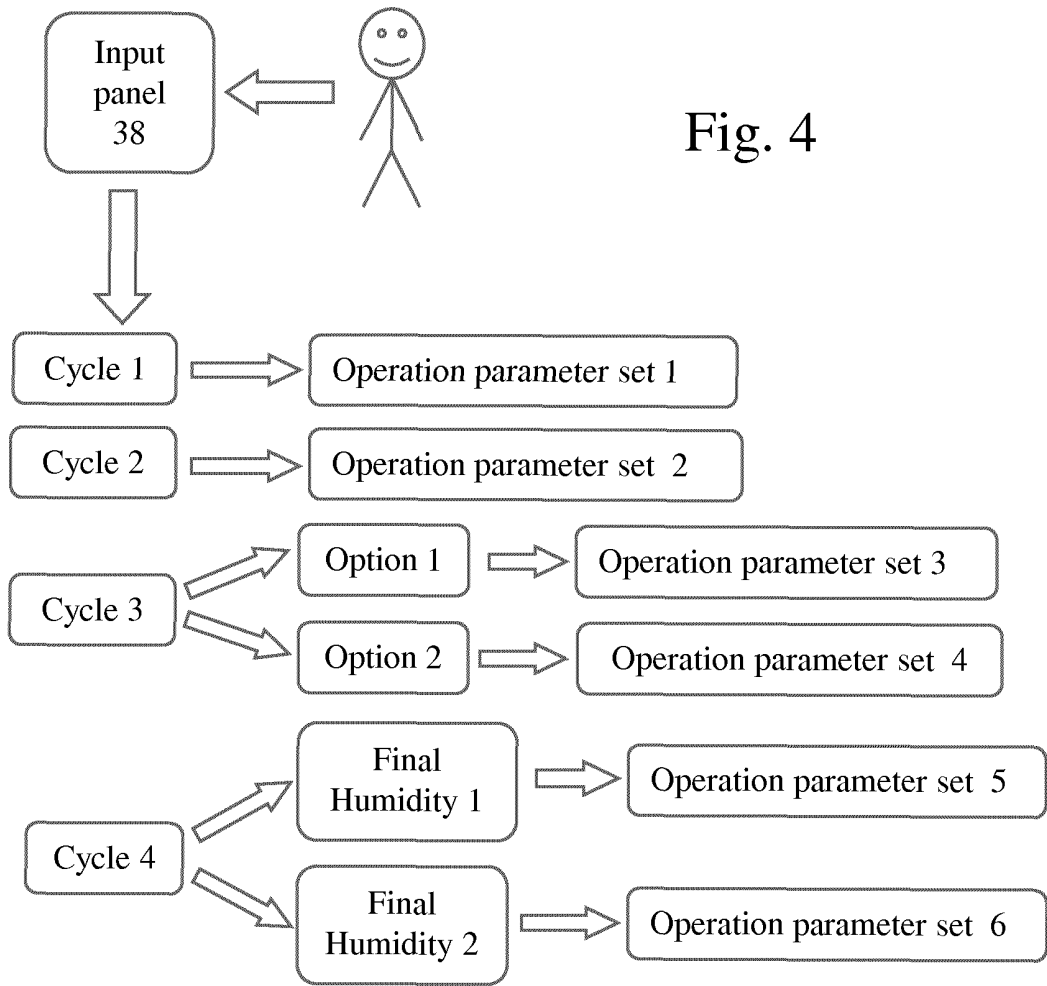

Fig. 4

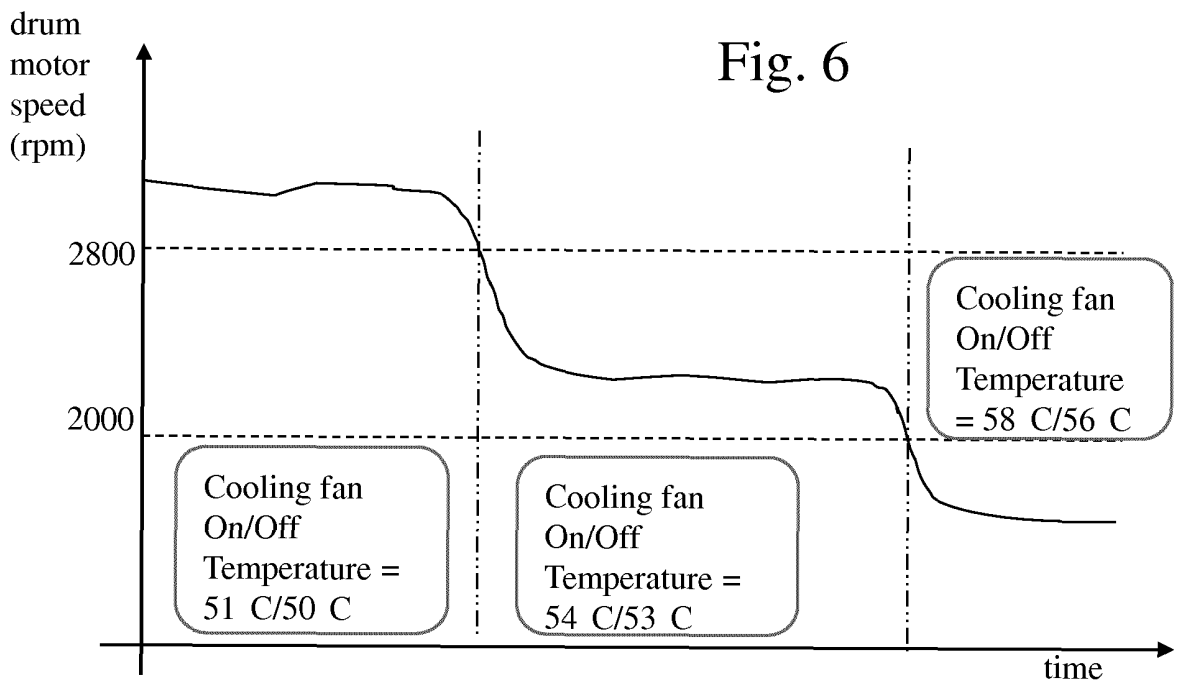

Fig. 6

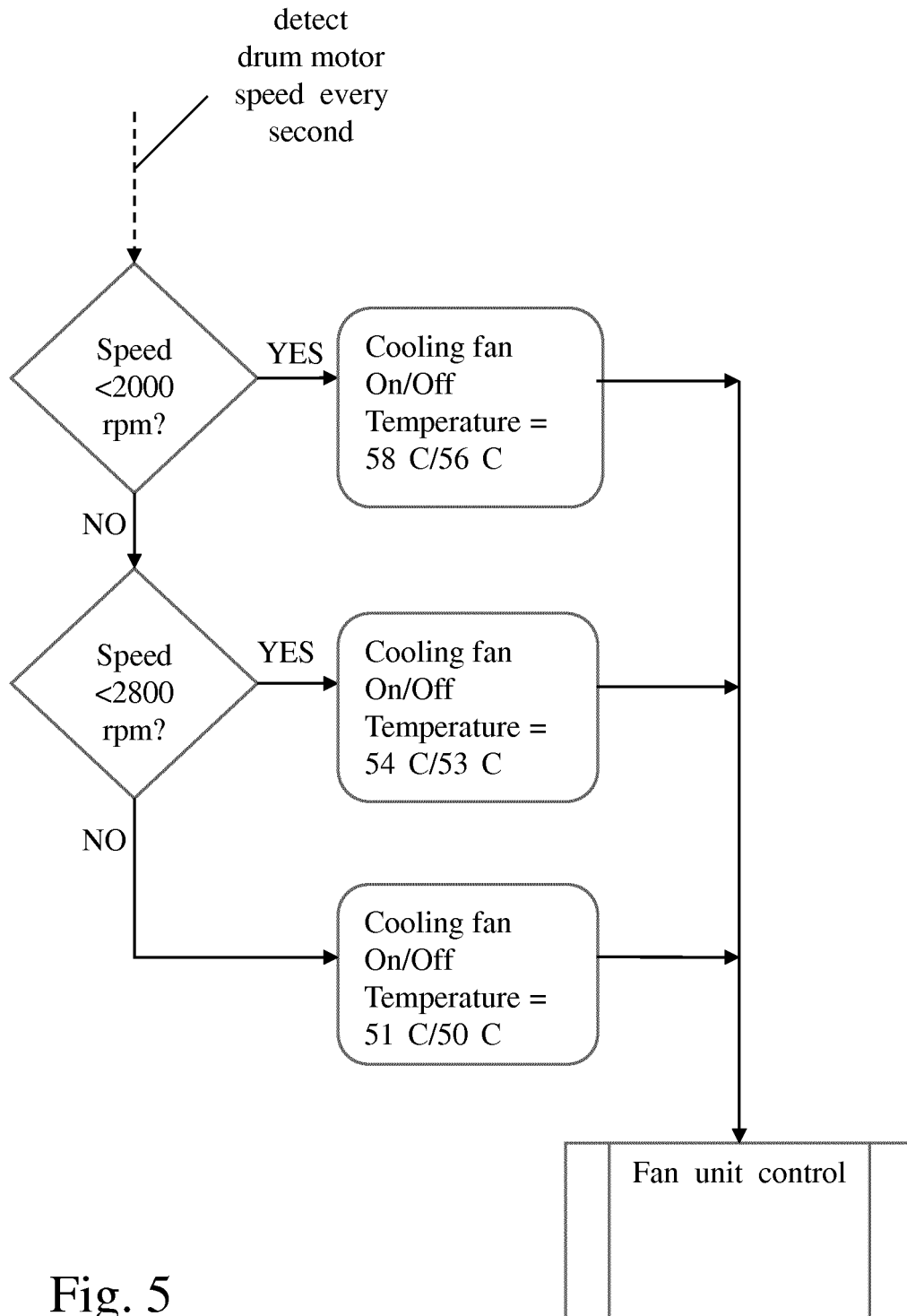

Fig. 5

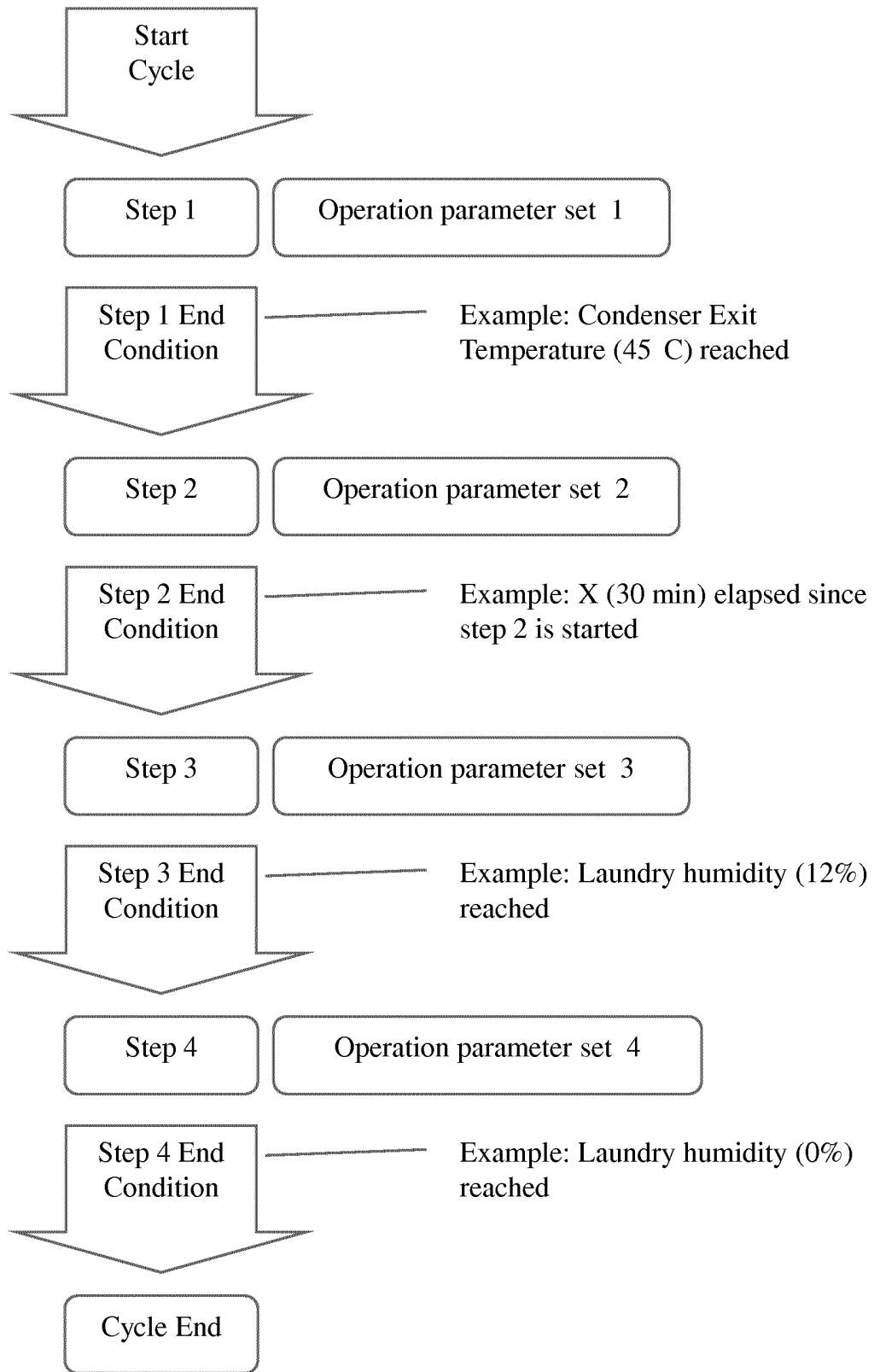

Fig. 7

REFERENCES CITED IN THE DESCRIPTION

This list of references cited by the applicant is for the reader's convenience only. It does not form part of the European patent document. Even though great care has been taken in compiling the references, errors or omissions cannot be excluded and the EPO disclaims all liability in this regard.

Patent documents cited in the description

- EP 2212463 B1 [0002]
- EP 1884586 A2 [0003]
- DE 4409607 A1 [0004]
- EP 19853234 A1 [0005]
- EP 2058427 A1 [0006]