



(12) **EUROPEAN PATENT APPLICATION**

(43) Date of publication:
23.09.2015 Bulletin 2015/39

(51) Int Cl.:
E05D 15/10^(2006.01)

(21) Application number: **14192783.0**

(22) Date of filing: **12.11.2014**

(84) Designated Contracting States:
AL AT BE BG CH CY CZ DE DK EE ES FI FR GB GR HR HU IE IS IT LI LT LU LV MC MK MT NL NO PL PT RO RS SE SI SK SM TR
 Designated Extension States:
BA ME

(72) Inventors:
 • **Shirahama, Tomohiko**
Tokyo, 101-8642 (JP)
 • **Saito, Daisuke**
Tokyo, 101-8642 (JP)

(30) Priority: **18.03.2014 JP 2014055454**

(74) Representative: **Schwabe - Sandmair - Marx**
Patentanwälte
Stuntzstraße 16
81677 München (DE)

(71) Applicant: **YKK AP Inc.**
Tokyo 101-8642 (JP)

(54) **FITTING**

(57) A fitting includes a movable sash 30 that is provided so as to be slidable relative to an opening frame 10 by abutting sash rollers 36 of a movable bottom rail 33 on a bottom guide surface 101 of a guide track 100 provided on a bottom frame member 12. The fitting includes a bottom slide member 40B that is provided on the movable bottom rail 33 so as to slide in the longitudinal direction of the movable bottom rail 33 when an operating handle 50 provided on the movable sash 30 is operated,

a pulling member 72 that is provided so as to be movable along the thickness direction of the movable bottom rail 33, and a drive mechanism (71, 74, and 76) that moves the pulling member 72 in the thickness direction of the movable bottom rail 33 according to the slide of the bottom slide member 40B. The movable sash 30 is moved in the thickness direction relative to the opening frame 10 by abutting the pulling member 72 on a thickness-direction-facing surface of a bottom frame member 12.

FIG.1

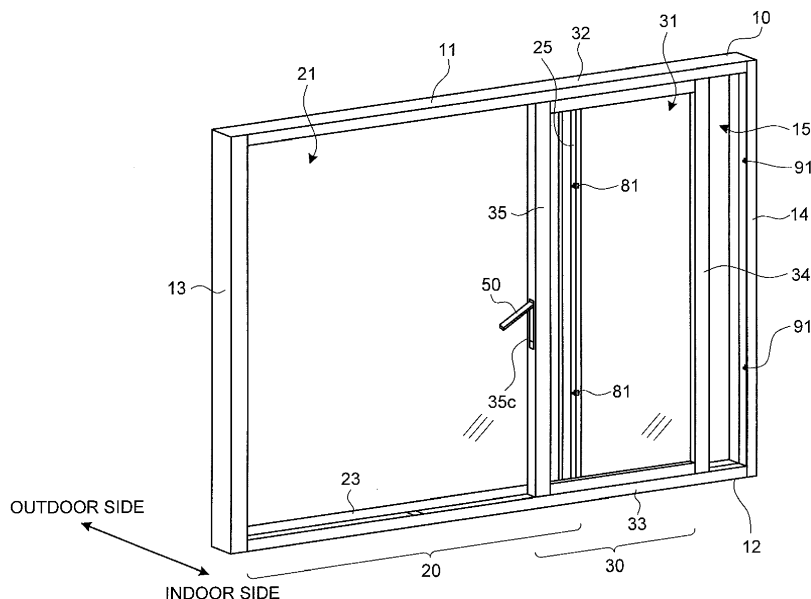

Description

CROSS-REFERENCE TO RELATED APPLICATIONS

[0001] The present application claims priority to and incorporates by reference the entire contents of Japanese Patent Application No. 2014-055454 filed in Japan on March 18, 2014.

BACKGROUND OF THE INVENTION

1. Field of the Invention

[0002] The present invention relates to a fitting that is configured such that a sash slides relative to an opening frame.

2. Description of the Related Art

[0003] In order to improve water tightness, heat insulating properties, and sound insulating properties of fittings configured such that a sash slides relative to an opening frame, fittings have been provided in which the sash obliquely slides immediately before closing so as to come close to the thickness direction surface of the opening frame, and rail and stile members of the sash are pressed on tight materials provided on the opening frame. In this type of fittings, the rail and stile members of the sash are apart from or only slightly in contact with the tight materials when the sash is in a state before closing. This enables the improvement in the water tightness, the heat insulating properties, and the sound insulating properties when the sash is closed, without increasing an operating force to slide the sash. However, obliquely sliding the sash to gradually press it on the tight materials causes the sash and the tight materials to slidingly contact each other, thereby increasing the operating force during this operation. In addition, in view of durability of the tight materials, this is not necessarily a desirable solution.

[0004] Hence, fittings have conventionally been provided in which an oblique guide mechanism is provided between a sash roller part and a lower frame part of a sash, and when the sash roller part slides relative to the lower frame part along a direction parallel to a track, an effect of the oblique guide mechanism is used to press the lower frame part on tight materials of an opening frame by moving the lower frame part in a direction orthogonal to the track (refer to Japanese National Publication of International Patent Application No. 2009-522470, for example).

[0005] However, in the fitting disclosed in Japanese National Publication of International Patent Application No. 2009-522470, the sash needs to be configured such that the sash roller part and the lower frame part can move relative to each other, resulting in a very complex structure. In addition, the sash roller part and the lower frame part support the load of the sash. As a result, mak-

ing the relative movement between the sash roller part and the lower frame part requires a large operating force to be applied. This is also not desirable in terms of operability. Moreover, moving the lower frame part relative to the sash roller part in the direction orthogonal to the track causes a large reaction force to be applied along the axle of the sash roller part. This may cause a problem in smooth sliding of the sash, such as generation of rattling of the axle.

SUMMARY OF THE INVENTION

[0006] It is an object of the present invention to provide a fitting that can improve water tightness, heat insulating properties, and sound insulating properties without causing structural complexity or problem in the sliding of the sash.

[0007] According to one aspect of the present invention, there is provided a fitting in which a sash is provided slidably along a longitudinal direction of a rail or stile member by rolling a rolling body provided on the rail or stile member on a guide surface along a thickness direction surface of a frame member, the fitting including: a slide member provided on the rail or stile member and configured to slide in the longitudinal direction of the rail or stile member; an operating handle provided on the sash and configured to slide the slide member relative to the rail or stile member when operated; a pulling member configured to move along a thickness direction of the rail or stile member; and a drive mechanism configured to move the pulling member in the thickness direction of the rail or stile member in accordance with sliding of the slide member, wherein the sash is configured to be moved in its thickness direction relative to an opening frame by abutting the pulling member on a thickness-direction-facing surface of the frame member.

[0008] According to this aspect of the present invention, sliding the slide member by operating the operating handle causes the pulling member to abut on the thickness-direction-facing surface of the frame member, and thereby moves the sash in the thickness direction thereof on the guide surface relative to the opening frame. Thus, the water tightness, the heat insulating properties, and the sound insulating properties can be improved without configuring the sash such that a rail or stile member and the rolling bodies can move relative to each other.

[0009] According to another aspect of the present invention, in the above-described fitting, the sash includes: an orthogonal rail or stile member disposed in a direction orthogonal to the rail or stile member; and an orthogonal slide member configured to slide in a longitudinal direction of the orthogonal rail or stile member and configured to slide in conjunction with the slide member, and an orthogonal pulling mechanism is interposed between the orthogonal rail or stile member and a thickness direction surface of an orthogonal frame member disposed facing a thickness direction surface of the orthogonal rail or stile member when the sash is closed, the orthogonal pulling

mechanism moving the orthogonal rail or stile member in the same direction as that of the rail or stile member in accordance with sliding of the orthogonal slide member.

[0010] According to this aspect of the present invention, sliding the orthogonal slide member also operates the orthogonal pulling mechanism interposed between the orthogonal rail or stile member and the orthogonal frame member to move the sash in the thickness direction.

[0011] According to still another aspect of the present invention, in the above-described fitting, the orthogonal pulling mechanism includes: an engaging pin projecting from the orthogonal frame member toward the thickness direction surface of the orthogonal rail or stile member, and having a larger outside diameter at a projecting end thereof than at a base thereof; an engaging inclined surface configured to face the base after the projecting end of the engaging pin has passed when the sash is closed, and configured to move the orthogonal frame member and the orthogonal rail or stile member closer to each other along the thickness direction by abutting on the base when the orthogonal slide member has slid; and an engaging portion configured to face the projecting end of the engaging pin when the orthogonal frame member and the orthogonal rail or stile member have moved closer to each other, and configured to restrict the sash from sliding toward a direction of opening by engaging with the projecting end.

[0012] According to this aspect of the present invention, the sash can move in the thickness direction relative to the opening frame, and can be restricted from sliding toward the direction of opening.

[0013] According to yet another aspect of the present invention, in the above-described fitting, the sash includes: the rolling body on a bottom rail member; a top guide member on a thickness direction surface of a top rail member; and a top slide member provided slidably along a longitudinal direction of the top rail member and configured to slide in conjunction with the slide member, a top guide groove having a pair of top guide surfaces along a sash width direction is formed on a frame member facing the top rail member, and the sash is provided so as to be slidable along the longitudinal direction of the top rail member in a state in which the top guide member abuts on the top guide surfaces, and the top guide member is supported so as to be movable along the thickness direction relative to the top rail member, and a shift mechanism is interposed between the top rail member and the top guide member, the shift mechanism moving the top guide member along the thickness direction relative to the top rail member according to the slide of the top slide member.

[0014] According to this aspect of the present invention, sliding the top slide member can move the sash along the thickness direction by simultaneously pulling the sash and the opening frame to each other at a plurality of places thereof.

[0015] The above and other objects, features, advantages and technical and industrial significance of this invention will be better understood by reading the following detailed description of presently preferred embodiments of the invention, when considered in connection with the accompanying drawings.

BRIEF DESCRIPTION OF THE DRAWINGS

10 **[0016]**

FIG. 1 is a perspective view of a fitting as an embodiment of the present invention, as viewed from the indoor side;

15 FIG. 2 is a transverse sectional view when a sash is closed in the fitting illustrated in FIG. 1;

FIG. 3 is a transverse sectional view when the sash is slightly opened in the fitting illustrated in FIG. 1;

20 FIG. 4 is a transverse sectional view of a state in which the sash is moved toward the outdoor side in the closed state in the fitting illustrated in FIG. 1;

FIG. 5 is a vertical sectional view of a portion of a slidable sash in the fitting illustrated in FIG. 1;

25 FIG. 6 is a vertical sectional view of a state in which the slidable sash is moved toward the outdoor side in the fitting illustrated in FIG. 1;

FIG. 7 is a vertical sectional view of a portion of a non-slidable sash in the fitting illustrated in FIG. 1;

30 FIG. 8 is an enlarged sectional view of an operating handle used on the sash of the fitting illustrated in FIG. 1;

FIG. 9 is an enlarged plan view of a top guide member used on the sash of the fitting illustrated in FIG. 1;

35 FIG. 10 is a sectional view of the top guide member illustrated in FIG. 9;

FIG. 11 is a perspective view when the top guide member illustrated in FIG. 9 is in a projecting attitude;

40 FIG. 12 is a perspective view when the top guide member illustrated in FIG. 9 is in a retracted attitude;

FIG. 13 is a plan view when the top guide member illustrated in FIG. 9 is in the retracted attitude;

45 FIG. 14 is a vertical sectional view of an essential part when the top guide member illustrated in FIG. 9 is in the retracted attitude;

FIG. 15 is a plan view of a state in which the top guide member illustrated in FIG. 9 is moved toward the outdoor side relative to the sash in the projecting attitude;

50 FIG. 16 is a plan view of a state in which the top guide member illustrated in FIG. 9 is moved toward the indoor side relative to the sash in the projecting attitude;

FIG. 17 is a transparent perspective view of the sash of the fitting illustrated in FIG. 1, as viewed from below;

55 FIG. 18 is a perspective view of a pulling mechanism used in the fitting illustrated in FIG. 1, as viewed from below;

FIG. 19 is a perspective view of a state in which the pulling mechanism illustrated in FIG. 18 has operated, as viewed from below;

FIGS. 20A to 20D are plan views for sequentially illustrating the operation of the pulling mechanism illustrated in FIG. 18;

FIG. 21 is an enlarged sectional view of an essential part of an orthogonal pulling mechanism on the tail end side used in the fitting illustrated in FIG. 1;

FIG. 22 is an enlarged sectional view of the essential part of a state in which the orthogonal pulling mechanism illustrated in FIG. 21 has operated;

FIG. 23 is an enlarged view of an essential part of an orthogonal pulling mechanism on the head end side used in the fitting illustrated in FIG. 1; and

FIG. 24 is an enlarged view of the essential part of a state in which the orthogonal pulling mechanism illustrated in FIG. 23 has operated.

DETAILED DESCRIPTION OF THE PREFERRED EMBODIMENT

[0017] The following describes a preferred embodiment of a fitting according to the present invention, with reference to the accompanying drawings.

[0018] FIG. 1 illustrates the fitting as an embodiment of the present invention. As illustrated in FIGS. 1 to 7, the fitting illustrated here is what is called a single sliding window that includes a fixed sash 20 fixed to an opening frame 10 and a movable sash 30 provided so as to slide right and left relative to the opening frame 10. The opening frame 10 is made by framing a top frame member (frame member) 11, a bottom frame member 12, and a pair of vertical frame members (orthogonal frame members) 13 and 14 into four peripheral sides. The present embodiment uses the opening frame 10 in which each of the frame members 11, 12, 13, and 14 is, in particular, made of wood. The fixed sash 20 is made by bonding a fixed top rail 22, a fixed bottom rail 23, a fixed head end stile 24, and a fixed tail end stile 25 (orthogonal frame member) to respective peripheral ends of a fixed multi-layered planar material 21 having a rectangular outer shape. The movable sash 30 is made by bonding a movable top rail (top rail or stile member) 32, a movable bottom rail (bottom rail or stile member) 33, a movable head end stile (orthogonal rail or stile member) 34, and a movable tail end stile (orthogonal rail or stile member) 35 to respective peripheral ends of a movable multi-layered planar material 31 having a rectangular outer shape. As understood from FIG. 1, the fixed sash 20 is formed to have a larger right-left width than that of the movable sash 30, and is positioned at a place to the left of the opening frame 10 when viewed from the indoor side. The movable sash 30 is positioned at a place on the indoor side of the fixed sash 20 so as to open and close an inner opening 15 formed by the opening frame 10 and the fixed sash 20. In the description below, when the vertical frame members of the opening frame 10 need to be distin-

guished from each other, the vertical frame member located on the left side in FIG. 1 will be called the "fixed vertical frame 13", and the vertical frame member located on the right side in FIG. 1 will be called the "head end vertical frame 14 (orthogonal frame member)".

Configuration of Fixed Sash 20

[0019] As illustrated in FIGS. 2 and 7, the fixed multi-layered planar material 21 of the fixed sash 20 is made by bonding together three fixed glass plates 211, 212, and 213. The three fixed glass plates 211, 212, and 213 have each a rectangular shape, two of them having the same outside dimensions as each other, and the remaining one being formed to have smaller vertical and transverse dimensions than those of the other two. In the description below, for convenience, the fixed glass plates having larger outside dimensions will be called the "first fixed glass plate 211" and the "second fixed glass plate 212", and the fixed glass plate having smaller outside dimensions will be called the "third fixed glass plate 213".

[0020] The first and the second fixed glass plates 211 and 212 are bonded to each other with a spacer member 214 interposed between peripheral ends of the respective glass plates, and have a heat-insulating space 215 formed therebetween. The third fixed glass plate 213 is bonded to a surface of the first fixed glass plate 211 with a spacer member 216 interposed between peripheral ends of the respective glass plates, and have a heat-insulating space 217 formed between the first and the third fixed glass plates 211 and 213. As understood from FIG. 2, the first fixed glass plate 211 is positioned such that an end face thereof serving as the tail end with respect to the third fixed glass plate 213 (end face on the right side in FIG. 2) lies on the same plane as that of the third fixed glass plate 213, and the other end faces serving as the head end (on the left side in FIG. 2), the top end, and the bottom end are in a projecting state from respective end faces of the third fixed glass plate 213.

[0021] Peripheral ends of the fixed multi-layered planar material 21 serving as the head end, the top end, and the bottom end are provided with cover members 218 and an end cover 219. The cover members 218 cover portions extending from a surface of the first fixed glass plate 211 to end faces of the first fixed glass plate 211 and end faces of the second fixed glass plate 212. The cover members 218 used in the present embodiment are formed of a metal, such as an aluminum alloy, and are bonded to the surface of the first fixed glass plate 211 with adhesive so as to cover the end faces of the first fixed glass plate 211 and the end faces of the second fixed glass plate 212. Respective spaces between the cover members 218 and the end faces of the first fixed glass plate 211 and the end faces of the second fixed glass plate 212 are filled with a sealing material 220. The end cover 219 covers a portion extending from a surface of the second fixed glass plate 212 to the end faces of the first fixed glass plate 211 and the end faces of the

second fixed glass plate 212 with the cover members 218 interposed between the end cover 219 and the end faces. The end cover 219 is also formed of a metal, such as an aluminum alloy, and is provided at ends of the fixed multi-layered planar material 21 by being bonded to the cover members 218 with adhesive.

[0022] The fixed top rail 22, the fixed bottom rail 23, and the fixed head end stile 24 are provided on the fixed multi-layered planar material 21 so as to cover surfaces at the respective peripheral ends of the third fixed glass plate 213 and the surface of the first fixed glass plate 211 projecting from the third fixed glass plate 213. The fixed tail end stile 25 is provided so as to cover the surface of the third fixed glass plate 213. These fixed rails and stiles 22, 23, 24, and 25 are formed of wood or a resin material.

[0023] The fixed top rail 22, the fixed bottom rail 23, and the fixed head end stile 24 are formed to have approximately the same dimension as one another along the thickness direction thereof, and are bonded to the surface of the first fixed glass plate 211 in the state of partially covering the cover members 218. Each of the fixed top rail 22, the fixed bottom rail 23, and the fixed head end stile 24 is bonded such that outer peripheral end faces thereof are located in positions receding from the end faces of the first fixed glass plate 211. In other words, the first fixed glass plate 211 projects higher than the end face of each of the fixed top rail 22, the fixed bottom rail 23, and the fixed head end stile 24, and is in a state of fully covering thickness-direction-facing surfaces 22a, 23a, and 24a on one side of the fixed top rail 22, the fixed bottom rail 23, and the fixed head end stile 24.

[0024] The fixed tail end stile 25 is formed in a step-like manner so as to have a dimension along the thickness direction larger on the outer peripheral side than on the inner peripheral side, and a fixed side facing surface 25a is formed between the outer and the inner peripheral sides. The dimension along the thickness direction of the portion on the inner peripheral side of the fixed tail end stile 25 is set so that the amount of projection from the third fixed glass plate 213 is approximately equal to those of the fixed rails 22 and 23 and the other fixed stile 24. A meeting part cover member 221 is provided at an outer peripheral end of the fixed tail end stile 25. The meeting part cover member 221 covers an end face of the fixed tail end stile 25 and end faces of the three fixed glass plates 211, 212, and 213, and is formed of a metal, such as an aluminum alloy.

[0025] The fixed sash 20 configured as described above is mounted on the opening frame 10 with the fixed head end stile 24 and the fixed top and bottom rails 22 and 23 interposed therebetween in the state in which the second fixed glass plate 212 is disposed on the outdoor side. More specifically, support frame members 16 formed of a metal, such as an aluminum alloy, are provided on the thickness direction surfaces of portions of the respective frame members 11, 12, and 13, except the head end vertical frame 14, where the fixed sash 20

is to be mounted, and the fixed sash 20 is mounted onto the opening frame 10 by fixing thereto the frame members 11, 12, and 13 corresponding to the individual support frame members 16. Between the support frame members 16 and the fixed sash 20, fixed tight materials 17 provided at the respective support frame members 16 are pressed into contact with the cover members 218 of the fixed sash 20, whereby desired air tightness and water tightness are ensured.

Configuration of Movable Sash 30

[0026] As illustrated in FIGS. 2 and 5, in the same manner as in the case of the fixed multi-layered planar material 21 of the fixed sash 20, the movable multi-layered planar material 31 of the movable sash 30 is made by bonding together three movable glass plates 311, 312, and 313. The three movable glass plates 311, 312, and 313 have each a rectangular shape, two of them having the same outside dimensions as each other, and the remaining one being formed to have smaller vertical and transverse dimensions than those of the other two. In the description below, for convenience, the movable glass plates having larger outside dimensions will be called the "first movable glass plate 311" and the "second movable glass plate 312", and the movable glass plate having smaller outside dimensions will be called the "third movable glass plate 313".

[0027] While having a different right-left width from that of the fixed multi-layered planar material 21 of the fixed sash 20, the movable multi-layered planar material 31 has the following points in common with the fixed multi-layered planar material 21 of the fixed sash 20. That is, the first and the second movable glass plates 311 and 312 have the same outside dimensions as each other, and have a heat-insulating space 315 formed therebetween by being bonded to each other with a spacer member 314 interposed therebetween; the third movable glass plate 313 has smaller vertical and transverse dimensions than those of the first movable glass plate 311, and has a heat-insulating space 317 formed between the first movable glass plate 311 and the first movable glass plate 311 by being bonded to each other with a spacer member 316 interposed therebetween; and the first movable glass plate 311 is positioned such that an end face thereof serving as the tail end with respect to the third movable glass plate 313 (end face on the right side in FIG. 2) lies on the same plane as that of the third movable glass plate 313, and the other end faces serving as the head end (on the left side in FIG. 2), the top end, and the bottom end are in a projecting state from respective end faces of the third movable glass plate 313.

[0028] Peripheral ends of the movable multi-layered planar material 31 serving as the head end, the top end, and the bottom end are provided with cover members 318. The cover members 318 are formed of a metal, such as an aluminum alloy, and are bonded with adhesive to a surface of the first movable glass plate 311 so as to

cover a portion extending from the surface of the first movable glass plate 311 to end faces of the first movable glass plate 311 and end faces of the second movable glass plate 312. Respective spaces between the cover members 318 and the end faces of the first movable glass plate 311 and the end faces of the second movable glass plate 312 are filled with a sealing material 320.

[0029] The movable top rail 32, the movable bottom rail 33, and the movable head end stile 34 are provided on the movable multi-layered planar material 31 so as to cover surfaces at respective peripheral ends of the third movable glass plate 313 and the surface of the first movable glass plate 311 projecting from the third movable glass plate 313. The movable tail end stile 35 is provided so as to cover a surface at a peripheral end of the third movable glass plate 313 and end faces of the three movable glass plates 311, 312, and 313. These movable rails and stiles 32, 33, 34, and 35 are formed of wood or a resin material in the same manner as in the case of the fixed rails and stiles 22, 23, 24, and 25.

[0030] The movable top rail 32, the movable bottom rail 33, and the movable head end stile 34 are formed to have approximately the same dimension as one another along the thickness direction thereof, and are bonded to the surface of the first movable glass plate 311 in the state of partially covering the cover members 318. Each of the movable top rail 32, the movable bottom rail 33, and the movable head end stile 34 is bonded such that outer peripheral end faces thereof are located in positions receding from the end faces of the first movable glass plate 311. In other words, the first movable glass plate 311 projects higher than the end face of each of the movable top rail 32, the movable bottom rail 33, and the movable head end stile 34, and is in a state of fully covering thickness-direction-facing surfaces 32a, 33a, and 34a on one side of the movable top rail 32, the movable bottom rail 33, and the movable head end stile 34.

[0031] In the movable tail end stile 35, the portion covering the surface at the peripheral end of the third movable glass plate 313 is made such that the amount of projection from the third movable glass plate 313 is approximately equal to those of the movable rails 32 and 33 and the other movable stile 34. In the movable tail end stile 35, the portion covering the end faces of the three movable glass plates 311, 312, and 313 is made such that the thickness-direction-facing surface thereof on the side of the second movable glass plate 312 has a stepped shape. Specifically, in the movable tail end stile 35, the thickness-direction-facing surface located on the side of the second movable glass plate 312 is made to lie, at the inner peripheral portion thereof, on approximately the same plane as a surface of the second movable glass plate 312, and to project, at the outer peripheral portion thereof, higher than the surface of the second movable glass plate 312, and a movable side facing surface 35a is formed between the inner and the outer peripheral portions.

[0032] As illustrated in FIGS. 5 and 17, the movable

sash 30 is provided with a plurality of sash rollers (rolling bodies) 36 at the movable bottom rail 33. The sash rollers 36 are provided such that the lower peripheral surface of each thereof projects downward from the lower surface of the movable bottom rail 33, and when placed on a guide surface along the horizontal direction, allow the movable sash 30 to slide along the longitudinal direction of the movable bottom rail 33 by appropriately rolling. As understood from FIG. 5, in the present embodiment, the lower peripheral surface of each of the sash roller 36 lies above an end face of the first movable glass plate 311 and an end face of the second movable glass plate 312.

Configurations of Slide Members 40 and Operating Handle 50 Provided at Movable Sash 30

[0033] As illustrated in FIGS. 2, 5 and 8, slide grooves 32b, 33b, 34b, and 35b are formed on the movable top rail 32, the movable bottom rail 33, the movable head end stile 34, and the movable tail end stile 35, respectively, of the movable sash 30, and the movable tail end stile 35 is provided with an operating handle 50.

[0034] The slide grooves 32b, 33b, 34b, and 35b are empty spaces formed along the longitudinal direction of the movable rails and stiles 32, 33, 34, and 35, respectively. The slide grooves 32b, 33b, and 34b are formed on the movable top rail 32, the movable bottom rail 33, and the movable head end stile 34, respectively, so as to be open on the thickness direction surface and so as to be located at a common position along the thickness direction. In the present embodiment, the slide grooves 32b, 33b, and 34b are formed so that the cover members 318 provided on respective side faces of the first movable glass plate 311 are exposed. At the movable tail end stile 35, the slide groove 35b is formed at a place located on the outer peripheral side of the end faces of the three movable glass plates 311, 312, and 313 but on the inner peripheral side of the movable side facing surface 35a so as to be open on both upper and lower end faces. The position of the slide groove 35b along the thickness direction is common with those of the slide grooves 32b, 33b, and 34b formed on the movable rails 32 and 33 and the other movable stile 34.

[0035] The respective slide grooves 32b, 33b, 34b, and 35b are provided with the respective slide members 40. The slide members 40 are long members housed in the slide grooves 32b, 33b, 34b, and 35b so as to be slidable only along the longitudinal direction of the movable rails and stiles 32, 33, 34, and 35, respectively, slide members 40 provided on the movable top rail 32, the movable head end stile 34, and the movable tail end stile 35 are each obtained by integrally forming a base 41 having a narrow flat-plate shape with a pair of ribs 42 projecting from both ends of the base 41 in the orthogonal direction thereto. The bases 41 are housed in the slide grooves 32b, 33b, and 34b approximately parallel to the thickness direction surfaces of the movable rails 32 and 33 and the movable stile 34. A slide member 40 used in the movable bottom

rail 33 has a flat-plate shape, and is housed in the slide groove 35b approximately orthogonally to the lower surface of the movable bottom rail 33. At the movable top rail 32, the movable bottom rail 33, and the movable head end stile 34, the cover members 318 exposed to the respective slide grooves 32b, 33b, and 34b abut on the slide members 40, thus restricting the movement of the slide members 40 in the direction of moving closer to the first movable glass plate 311. While not explicitly illustrated in any of FIGS. 2, 5 and 8, the slide members 40 provided at the movable rails and stiles 32, 33, 34, and 35 are connected together between respective ends thereof by flexible power transmission members so as to slide in a mutually coupled manner. In the description below, when the slide members 40 need to be distinguished from one another, a slide member of the movable top rail 32 will be called a "top slide member (shift mechanism) 40A"; a slide member of the movable bottom rail 33 will be called a "bottom slide member (slide member) 40B"; a slide member of the movable head end stile 34 will be called a "head end slide member (orthogonal slide member: engaging portion) 40C"; and a slide member of the movable tail end stile 35 will be called a "tail end slide member (orthogonal slide member) 40D".

[0036] As illustrated in FIG. 8, the operating handle 50 is rotatably installed in a housing depression 35c provided on the tail end face of the movable tail end stile 35, and can move from a state of being housed in the housing depression 35c of the movable tail end stile 35, as indicated by a solid line in FIG. 8, to a state of projecting from the housing depression 35c of the movable tail end stile 35, as indicated in FIG. 1 and by chain double-dashed lines in FIG. 8. The operating handle 50 is linked to the tail end slide member 40D provided at the movable tail end stile 35, and can slide all the slide members 40 via the tail end slide member 40D by being operated so as to rotate around the shaft center of a support shaft 51. The present embodiment is configured such that operating the operating handle 50 in the direction of housing it in the housing depression 35c causes the tail end slide member 40D to slide upward, which in turn causes the top slide member 40A to slide toward the head end, the head end slide member 40C to slide downward, and the bottom slide member 40B to slide toward the tail end. In contrast, operating the operating handle 50 in the direction of projecting it from the housing depression 35c causes the tail end slide member 40D to slide downward, which in turn causes the top slide member 40A to slide toward the tail end, the head end slide member 40C to slide upward, and the bottom slide member 40B to slide toward the head end.

[0037] While not explicitly illustrated in FIG. 8, an urging unit that urges the operating handle 50 toward the state of projecting from the housing depression 35c is interposed between the operating handle 50 and the movable tail end stile 35. Housing the operating handle 50 in the housing depression 35c against an urging force of the urging unit (not illustrated) can engage the oper-

ating handle 50 with a latch 52 provided in the housing depression 35c so as to place the operating handle 50 in the state of being housed in the housing depression 35c. Releasing the latch 52 causes the urging force of the urging unit (not illustrated) to project the operating handle 50 from the housing depression 35c to place the operating handle 50 in an operable state.

Configurations of Top Guide Member 60 and Shift Mechanism Provided at Movable Sash 30

[0038] As illustrated in FIGS. 5, 9, and 10, a top guide member 60 is provided at a place located approximately at the longitudinal center of the movable top rail 32 on the movable sash 30. The top guide member 60 includes a guide arm 61 and guide rollers 62 provided at both ends of the guide arm 61. The guide arm 61 is a narrow plate-like member that is long enough to be capable of projecting both ends thereof from the respective thickness-direction-facing surfaces of the movable sash 30. The guide arm 61 has a support pin (shift mechanism) 63 in a position located approximately at the longitudinal center thereof, and is rotatably supported at the tip of a support arm 64 via the support pin 63. The support arm 64 is a long sheet member provided in a space surrounded by the base 41 and the pair of ribs 42 of the top slide member 40A in the slide groove 32b formed on the movable top rail 32, and is supported, via the base end thereof, on the upper surface of the movable top rail 32 by a mounting screw 65. The support arm 64 is formed to have a smaller width than the interdistance between the pair of ribs 42, and the tip thereof can move between the pair of ribs 42 around the mounting screw 65 serving as an axial center of the tip.

[0039] The guide arm 61 is supported at the tip of the support arm 64 in a state of being exposed out of the top slide member 40A by inserting the support pin 63 through an upper cam hole (shift mechanism) 43 formed in the base 41 of the top slide member 40A. The upper cam hole 43 includes two positioning hole portions 43a and 43b along the longitudinal direction of the top slide member 40A and a connecting hole portion 43c that connects the positioning hole portions 43a and 43b to each other. The two positioning hole portions 43a and 43b and the connecting hole portion 43c are formed to have a width approximately equal to the outside diameter of the support pin 63. As illustrated in FIG. 9, the two positioning hole portions 43a and 43b are formed in positions displaced from each other in the thickness direction of the movable sash 30, and the connecting hole portion 43c is formed in a slanting manner relative to the longitudinal direction of the top slide member 40A so as to connect ends of the two positioning hole portions 43a and 43b to each other. Sliding the top slide member 40A along the longitudinal direction of the movable top rail 32 changes the position of the support pin 63 between the two positioning hole portions 43a and 43b with respect to the upper cam hole 43. This moves the guide arm 61 supported

at the tip of the support arm 64 via the support pin 63 between a position nearer to the second movable glass plate 312 of the movable multi-layered planar material 31 and a position nearer to the third movable glass plate 313 of the movable multi-layered planar material 31. In the present embodiment, as illustrated in FIG. 9, the upper cam hole 43 is formed such that the positioning hole portion 43a located on the head end side of the top slide member 40A is positioned nearer to the second movable glass plate 312 of the movable multi-layered planar material 31 than the positioning hole portion 43b located on the tail end side of the top slide member 40A, and thereby, moving the top slide member 40A toward the head end moves the guide arm 61 nearer to the third movable glass plate 313 of the movable multi-layered planar material 31 with respect to the movable sash 30.

[0040] The guide rollers 62 are provided at both ends of the guide arm 61 in a state in which the circumferential surface of each of the guide rollers 62 projects from the guide arm 61, with a roller shaft 62a interposed between the guide roller 62 and the guide arm 61. Each of the guide rollers 62 can rotate around the roller shaft 62a disposed parallel to the support pin 63.

Configuration for Changing Attitude of Top Guide Member 60 Between Projecting Attitude and Retracted Attitude

[0041] An end of the guide arm 61 is linked to an end of a regulating arm (a first arm of a regulating member) 66. As illustrated in FIGS. 11 and 12, the regulating arm 66 is rotatably supported, via the base end thereof, at the tip of an operating arm (a second arm of a regulating member) 67. The operating arm 67 is a long member provided on the upper surface of the movable top rail 32, and is supported on the upper surface of the movable top rail 32 via two sliding guides 68 so as to be slidable only along the longitudinal direction of the movable top rail 32. The operating arm 67 is formed long enough so that the base end thereof can be projecting from the head end surface of the movable head end stile 34 by sliding the operating arm 67 toward the head end.

[0042] As illustrated in FIGS. 9 and 11, when the operating arm 67 slides toward the tail end, the regulating arm 66 functions to rotate the guide arm 61 so that the guide arm 61 becomes approximately orthogonal to the top slide member 40A and is placed in an attitude (projecting attitude) in which both ends of the guide arm 61 project from the respective thickness-direction-facing surfaces of the movable sash 30. In this state, the base end surface of the operating arm 67 approximately coincides with the head end surface of the movable head end stile 34, and both ends of the guide arm 61 can be kept projecting from the thickness-direction-facing surfaces of the movable sash 30 by locking the base end of the operating arm 67 on a locking member (regulating member) 69 provided at the top end of the movable head end stile 34.

[0043] When the locking state between the base end of the operating arm 67 and the locking member 69 is released and the operating arm 67 slides toward the head end as illustrated in FIGS. 12 and 13, the guide arm 61 rotates so that the joint between the guide arm 61 and the regulating arm 66 is pulled toward the operating arm 67. When the operating arm 67 has slid until the base end projects from the head end surface of the movable head end stile 34 as illustrated in FIG. 12, the guide arm 61 and the pair of guide rollers 62 are placed in an attitude (retracted attitude) in which both the guide arm 61 and the pair of guide rollers 62 are disposed within a width along the thickness direction of the movable sash 30, as illustrated in FIGS. 13 and 14.

Configuration of Pulling Mechanism 70

[0044] As illustrated in FIGS. 17 to 19, the movable bottom rail 33 of the movable sash 30 is provided with a pulling mechanism 70. The pulling mechanism 70 includes a base block (drive mechanism) 71 and a pulling member 72. The base block 71 is installed in a housing cutout 33c formed on the lower surface of the movable bottom rail 33. The housing cutout 33c is formed so as to communicate with the slide groove 33b formed on the movable bottom rail 33. The base block 71 is connected to the bottom slide member 40B, and is supported so as to be slidable along the longitudinal direction of the movable bottom rail 33 by screwing slide screws 73 into the movable bottom rail 33 through respective elongated holes 71a formed at both ends of the base block 71. The pulling member 72 is a flat plate-like member provided on the lower surface of the base block 71, and is fastened, through the base end thereof, together with the base block 71 by one of the slide screws 73 that is screwed on the tail end side of the movable bottom rail 33. The pulling member 72 is provided with a lower cam hole (drive mechanism) 74 and an abutting piece 75. As illustrated in FIGS. 20A to 20D, the lower cam hole 74 approximately linearly extends from the base end side toward the tip side of the pulling member 72, then slopes in a direction gradually departing from the bottom slide member 40B, and further, approximately linearly extends toward the tip. A cam pin 76 extends through the lower cam hole 74. The cam pin (drive mechanism) 76 is a cylindrical member provided at the base block 71, and is formed to have an outside diameter that can be slidably inserted in the lower cam hole 74. As illustrated in FIGS. 5 and 6, the abutting piece 75 is a flat plate portion that projects downward from an end of the tip of the pulling member 72 nearer to the movable glass plate 311. As understood from FIGS. 5 and 6, the abutting piece 75 is formed so that the position of the projecting lower end face thereof projects slightly below the lower peripheral surface of the sash rollers 36.

[0045] As illustrated in FIGS. 18 and 20A, when the base block 71 lies nearest to the head end, the pulling member 72 is disposed such that the cam pin 76 is po-

sitioned on the tip side of the lower cam hole 74, and the abutting piece 75 is disposed in a state of abutting on a cover member 318 of the first movable glass plate 311. From this state, as illustrated in FIGS. 19 and 20B to 20D, sliding the base block 71 toward the tail end gradually moves the cam pin 76 toward the base end of the pulling member 72 relative to the lower cam hole 74, which in turn rotates the pulling member 72 around one of the slide screws 73 serving as an axial center of the pulling member 72, and moves the tip of the pulling member 72 along the thickness direction of the movable bottom rail 33 in a direction departing from the cover member 318 of the first movable glass plate 311.

Configuration of Opening Frame 10 for Slidably Supporting Movable Sash 30

[0046] As illustrated in FIGS. 2 and 5, the opening frame 10 that slidably supports the movable sash 30 is provided with a guide track 100 and a slide housing groove 110 on the bottom frame member 12, and provided with a top guide groove 120 and a housing portion 130 on the top frame member 11.

[0047] The guide track 100 is a long member provided on the upper surface of the bottom frame member 12 along the longitudinal direction of the bottom frame member 12, and has a bottom guide surface (guide surface) 101 on the upper surface thereof. The bottom guide surface 101 is a flat surface along the upper surface of the bottom frame member 12, and is formed wide enough so that the sash rollers 36 can be placed thereon. Both side portions of the bottom guide surface 101 are provided with inclined surfaces 102 that are mildly inclined upward in a gradual manner. The inclined surfaces 102 function so that the sash rollers 36 of the movable sash 30 abut on the bottom guide surface 101. A pulling abutment surface 103 for abutting against the abutting piece 75 of the pulling member 72 is formed on a portion located on the outdoor side of the guide track 100.

[0048] The slide housing groove 110 is a depression formed at a place on the upper surface of the bottom frame member 12 on the outdoor side of the guide track 100, and is formed along the longitudinal direction of the bottom frame member 12. The slide housing groove 110 is used for avoiding the end of the first movable glass plate 311 and the end of the second movable glass plate 312 that project below the movable bottom rail 33 from interfering with the bottom frame member 12 when the sash rollers 36 of the movable sash 30 are placed on the bottom guide surface 101 of the guide track 100. The slide housing groove 110 is formed to have a larger width than the dimension along the thickness direction of the first and the second movable glass plates 311 and 312.

[0049] The top guide groove 120 is a depression formed on the lower surface of the top frame member 11 along the longitudinal direction of the top frame member 11, and has a pair of top guide surfaces 121 along the sash width direction. The top guide surfaces 121 are

formed to have a space therebetween that allows the circumferential surfaces of the guide rollers 62 provided at the respective ends of the guide arm 61 of the top guide member 60 to abut on the top guide surfaces 121 when the guide arm 61 is placed in the projecting attitude.

[0050] The housing portion 130 is a depression formed in the upper surface of the top guide groove 120. The housing portion 130 is formed to have a size that can accommodate the two sliding guides 68, the regulating arm 66, and the operating arm 67 together with the guide arm 61 and the guide rollers 62 only when the guide arm 61 and the guide rollers 62 of the top guide member 60 are placed in the retracted attitude.

[0051] A head end housing groove 140 is formed in the thickness direction surface of the head end vertical frame 14 of the opening frame 10. The head end housing groove 140 is a depression formed along the longitudinal direction of the head end vertical frame 14, and is formed wide enough to be capable of accommodating the head end of the movable sash 30. A side face located on the outdoor side of the head end housing groove 140 is located on the same plane as that of a thickness-direction-facing surface facing the indoor side on the fixed tail end stile 25 of the fixed sash 20.

Operation When Mounting Movable Sash 30 to Opening Frame 10

[0052] To support the movable sash 30 on the opening frame 10 configured as described above, the operating arm 67 is first slid toward the head end, and the operating handle 50 is kept projecting from the housing depression 35c. In this state, the top guide member 60 is kept in the retracted attitude, so that the movable top rail 32 can be accommodated in the top guide groove 120 of the top frame member 11, and the top guide member 60 can be accommodated in the housing portion 130. The abutting piece 75 of the pulling member 72 is placed in the state of abutting on the cover member 318 of the first movable glass plate 311, so that the first and the second movable glass plates 311 and 312 of the movable sash 30 can be easily accommodated in the slide housing groove 110 of the bottom frame member 12.

[0053] From this state, the movable top rail 32 of the movable sash 30 is first disposed in the top guide groove 120 of the top frame member 11, and then, the movable sash 30 is moved up while keeping the state in which the top guide member 60 in the retracted attitude is housed in the housing portion 130. Thereafter, the movable sash 30 is moved so that the movable bottom rail 33 comes close to the bottom frame member 12; the end of the first movable glass plate 311 and the end of the second movable glass plate 312 are positioned to face the slide housing groove 110, and the sash rollers 36 provided at the movable bottom rail 33 are positioned to face the bottom guide surface 101 of the guide track 100; and the movable sash 30 is moved downward to place the sash rollers 36 on the bottom guide surface 101. Lastly, the operating

arm 67 projecting from the head end only needs to be slid toward the tail end to lock the base end of the operating arm 67 on the locking member 69 of the movable head end stile 34.

[0054] In this state, the guide arm 61 of the top guide member 60 provided at the movable top rail 32 is in the projecting attitude. As a result, the guide rollers 62 abut on respective guide surfaces of the top guide groove 120 provided on the top frame member 11, so that the movable top rail 32 is supported on the top frame member 11 so as to be slidable along the longitudinal direction thereof. The sash rollers 36 provided at the movable bottom rail 33 abut on the bottom guide surface 101 of the guide track 100 provided on the bottom frame member 12, so that the movable bottom rail 33 is supported on the bottom frame member 12 so as to be slidable along the longitudinal direction thereof. As a result, as illustrated in FIGS. 2 and 3, the inner opening 15 of the opening frame 10 can be opened and closed by sliding the movable sash 30 relative to the opening frame 10.

[0055] Closing the movable sash 30 relative to the opening frame 10 arranges the fixed tail end stile 25 of the fixed sash 20 and the movable tail end stile 35 of the movable sash 30 side by side along the thickness direction, as illustrated in FIG. 2. At this time, in the fitting, the fixed side facing surface 25a provided on the fixed tail end stile 25 and the movable side facing surface 35a provided on the movable tail end stile 35 are arranged facing each other in close positions with a gap held between the surfaces.

[0056] As understood from FIGS. 2 and 5, movable tight materials 150 are provided at portions on the top frame member 11, the bottom frame member 12, and the head end vertical frame 14 that face peripheral ends of the second movable glass plate 312 when the movable sash 30 is closed, and a movable tight material 150 is provided at a portion on the fixed tail end stile 25 of the fixed sash 20 that faces a peripheral end of the second movable glass plate 312 when the movable sash 30 is closed. When the operating handle 50 is projecting from the housing depression 35c, each of these movable tight materials 150 are disposed in a state of being apart from the surface of the second movable glass plate 312.

Configuration of Tail End Orthogonal Pulling Mechanism 80 Provided Between Fixed Tail End Stile 25 and Movable Tail End Stile 35

[0057] As illustrated in FIGS. 2, 3, 21 and 22, a tail end orthogonal pulling mechanism 80 provided between the fixed tail end stile 25 and the movable tail end stile 35 includes a tail end engaging pin 81 on the fixed tail end stile 25 and a pulling plate (engaging portion) 82 on the movable tail end stile 35. As illustrated in FIG. 3, the tail end engaging pin 81 has a head 81b having a larger outside diameter at the tip of a shank 81a having a cylindrical shape, and is installed in a projecting manner from the fixed side facing surface 25a of the fixed tail end

stile 25 through the shank 81a. The shank 81a of the tail end engaging pin 81 is provided with a collar member (base) 83 so as to cover the outer circumference of the shank 81a. As illustrated in FIGS. 2 and 3, the head 81b of the tail end engaging pin 81 is provided so as to be offset from the shank 81a toward the indoor side, so that only a portion located on the indoor side of the circumferential surface of the collar member 83 projects in a radial direction. While not explicitly illustrated in either of FIGS. 2 and 3, the tail end engaging pin 81 is provided in two positions at an upper portion and a lower portion of the fixed tail end stile 25. As illustrated in FIG. 2, the shank 81a of the tail end engaging pin 81 is formed to have a larger length than that of the gap held between the fixed side facing surface 25a and the movable side facing surface 35a of the movable tail end stile 35 that faces the fixed side facing surface 25a when the movable sash 30 is closed.

[0058] As illustrated in FIGS. 2, 3, 21 and 22, the pulling plate 82 is a sheet-like member provided so as to project from a plate housing groove 35d of the movable tail end stile 35 and so as to cover the movable side facing surface 35a of the movable tail end stile 35. While not explicitly illustrated in any of FIGS. 2, 3, 21 and 22, the pulling plate 82 is provided in two positions at an upper portion and a lower portion corresponding to the tail end engaging pins 81 of the fixed tail end stile 25. The plate housing groove 35d is an opening formed so as to communicate with the slide groove 35b from each thickness-direction-facing surface in the movable tail end stile 35 facing the fixed tail end stile 25. Each of the pulling plates 82 is connected, at the base end thereof, to the tail end slide member 40D, and moves up and down relative to the movable tail end stile 35 by being coupled with the sliding of the tail end slide member 40D.

[0059] Each of the pulling plates 82 is provided with a pair of slide rollers 84 and a tail end cam hole 85. The slide rollers 84 are provided at upper and lower portions of a part of the pulling plate 82 located in the plate housing groove 35d, and can each rotate around the shaft center orthogonal to the movable side facing surface 35a. The slide rollers 84 abut, at respective circumferential surfaces thereof, on a slide plate 86 provided so as to cover the plate housing groove 35d, and thereby restrict the pulling plate 82 and the tail end slide member 40D from moving toward the outdoor side relative to the movable tail end stile 35.

[0060] As illustrated in FIGS. 21 and 22, the tail end cam hole 85 is a special-shaped hole formed at a portion of the pulling plate 82 projecting from the plate housing groove 35d, and has a tail end pin insertion hole portion 85a at an upper part and a tail end pin engaging hole portion 85b at a lower part thereof. The tail end pin insertion hole portion 85a is an opening formed to have a width that allows the head 81b of the tail end engaging pin 81 provided on the fixed tail end stile 25 to be inserted therethrough. The tail end pin insertion hole portion 85a is formed at a position that faces the tail end engaging

pin 81 of the fixed tail end stile 25 when the tail end slide member 40D has moved down by projecting the operating handle 50 from the housing depression 35c. The tail end pin engaging hole portion 85b is an opening formed to have a width that allows the collar member 83 of the tail end engaging pin 81 to be inserted, and prevents the head 81b from being inserted therethrough. A tail end inclined guide surface (engaging inclined surface) 85c is provided at a portion located between the tail end pin insertion hole portion 85a and the tail end pin engaging hole portion 85b on an inner wall surface located on the outdoor side of the tail end cam hole 85. The tail end inclined guide surface 85c is inclined gradually toward the outdoor side as the position thereof shifts from the tail end pin engaging hole portion 85b toward the tail end pin insertion hole portion 85a. A portion on a movable facing surface of the movable tail end stile 35 facing the tail end engaging pin 81 is provided with a tail end depression 35e for accommodating the head 81b of the tail end engaging pin 81 when the movable sash 30 is closed.

Configuration of Head End Orthogonal Pulling Mechanism 90 Provided Between Head End Vertical Frame 14 and Movable Head End Stile 34

[0061] As illustrated in FIGS. 2, 3, 23, and 24, a head end orthogonal pulling mechanism 90 provided between the head end vertical frame 14 and the movable head end stile 34 includes a head end engaging pin 91 at a place in the head end housing groove 140 of the head end vertical frame 14 facing the head end slide member 40C, and has a head end cam hole 92 at the head end slide member 40C of the movable head end stile 34. In the same manner as the tail end engaging pin 81, the head end engaging pin 91 includes a collar member (base) 93 on the outer circumference of a shank 91a having a cylindrical shape, and has a head 91b having a larger outside diameter at the tip of the shank 91a in a position offset therefrom toward the indoor side. Such head end engaging pins 91 are installed in a projecting manner from an upper portion and a lower portion of the head end housing groove 140 through the shank 91a. As illustrated in FIG. 2, the shank 91a of the head end engaging pin 91 is formed to have a larger length than that of the gap held between the thickness direction surface of the head end housing groove 140 and the head end surface of the movable head end stile 34 when the movable sash 30 is closed.

[0062] As illustrated in FIGS. 23 and 24, the head end cam hole 92 is a special-shaped hole formed in the head end slide member 40C, and has a head end pin insertion hole portion 92a at a lower part and a head end pin engaging hole portion 92b at an upper part thereof. The head end pin insertion hole portion 92a is an opening formed to have a width that allows the head 91b of the head end engaging pin 91 provided on the head end vertical frame 14 to be inserted therethrough. The head end pin insertion hole portion 92a is formed at a position that

faces the head end engaging pin 91 of the head end vertical frame 14 when the head end slide member 40C has moved up by projecting the operating handle 50 from the housing depression 35c. The head end pin insertion hole portion 92a is an opening formed to have a width that allows the collar member 93 of the head end engaging pin 91 to be inserted, and prevents the head 91b from being inserted therethrough. A head end inclined guide surface (engaging inclined surface) 92c is provided at a portion located between the head end pin insertion hole portion 92a and the head end pin engaging hole portion 92b on an inner wall surface located on the outdoor side of the head end cam hole 92. The head end inclined guide surface 92c is inclined gradually toward the outdoor side as the position thereof shifts from the head end pin engaging hole portion 92b toward the head end pin insertion hole portion 92a. A portion on the head end surface of the movable tail end stile 35 facing the head end engaging pin 91 is provided with a head end depression 34e for accommodating the head 91b of the head end engaging pin 91 when the movable sash 30 is closed. At portions above and below the head end cam hole 92 in the head end slide member 40C, elongated holes 45 are formed along the longitudinal direction of the head end slide member 40C, and guide screws 44 are screwed in the respective elongated holes 45. The guide screws 44 are used for preventing the head end slide member 40C from moving in the thickness direction of the movable head end stile 34.

Operation of Operating Handle 50 When Operated

[0063] As described above, while the operating handle 50 is projecting from the housing depression 35c, the movable tight materials 150 provided on the top and the bottom frame members 11 and 12 and the head end vertical frame 14 and the movable tight material 150 provided on the fixed tail end stile 25 of the fixed sash 20 are all apart from the second movable glass plate 312 of the movable sash 30, as illustrated in FIGS. 2 and 5. As a result, this fitting can reduce the operating force for sliding the movable sash 30 in order to open or close the inner opening 15 of the opening frame 10.

[0064] While the movable sash 30 is closed, housing the operating handle 50 in the housing depression 35c causes each of the tail end slide member 40D, the top slide member 40A, the head end slide member 40C, and the bottom slide member 40B to slide, and, as a result, presses the movable tight materials 150 into contact with the four peripheral sides of the second movable glass plate 312 of the movable sash 30.

[0065] Specifically, operating the operating handle 50 in the direction of housing it in the housing depression 35c causes the tail end slide member 40D to slide upward, and thereby brings the tail end orthogonal pulling mechanism 80 from the state illustrated in FIG. 21 into the state illustrated in FIG. 22; thus, the collar member 83 of the tail end engaging pin 81 abuts on the tail end

inclined guide surface 85c, whereby the movable tail end stile 35 moves toward the outdoor side relative to the opening frame 10. This brings the movable tight material 150 provided on the fixed tail end stile 25 into the state of being pressed into contact with the peripheral end of the second movable glass plate 312 located on the tail end side thereof, as illustrated in FIG. 4.

[0066] In the same manner, operating the operating handle 50 in the direction of housing it in the housing depression 35c causes the head end slide member 40C to slide downward, and thereby brings the head end orthogonal pulling mechanism 90 from the state illustrated in FIG. 23 into the state illustrated in FIG. 24; thus, the collar member 93 of the head end engaging pin 91 abuts on the head end inclined guide surface 92c, whereby the movable head end stile 34 moves toward the outdoor side relative to the opening frame 10. This brings the movable tight material 150 provided on the head end vertical frame 14 into the state of being pressed into contact with the peripheral end of the second movable glass plate 312 located on the head end side thereof, as illustrated in FIG. 4.

[0067] In addition, while the operating handle 50 is housed in the housing depression 35c, the head 81b of the tail end engaging pin 81 is positioned in the tail end pin engaging hole portion 85b at the tail end orthogonal pulling mechanism 80, and the head 91b of the head end engaging pin 91 is positioned in the head end pin engaging hole portion 92b at the head end orthogonal pulling mechanism 90. As a result, sliding the movable sash 30 relative to the opening frame 10 in the opening direction thereof causes the head 81b of the tail end engaging pin 81 to engage with the pulling plate 82, and the head 91b of the head end engaging pin 91 to engage with the head end slide member 40C. This can bring the movable sash 30 into a locked state of being restricted from sliding.

[0068] Moreover, operating the operating handle 50 in the direction of housing it in the housing depression 35c causes the top slide member 40A to slide toward the head end, and thereby brings the relation between movable top rail 32 and the top frame member 11 from the state illustrated in FIG. 15 into the state illustrated in FIG. 16; thus, the top guide member 60 moves toward the indoor side relative to the movable top rail 32.

[0069] In the top guide member 60 of the movable top rail 32, both ends of the guide arm 61 are in the state of abutting on the top guide surfaces 121 of the top guide groove 120 through the guide rollers 62, thus not being movable in the thickness direction relative to the top frame member 11. As a result, moving the top guide member 60 toward the indoor side relative to the movable top rail 32 causes the movable top rail 32 to move toward the outdoor side relative to the top frame member 11. This brings the movable tight material 150 provided on the top frame member 11 into the state of being pressed into contact with the peripheral end of the second movable glass plate 312 located at the top thereof, as illustrated in FIG. 6.

[0070] Furthermore, operating the operating handle 50 in the direction of housing it in the housing depression 35c causes the bottom slide member 40B to slide toward the tail end, and thereby brings the relation between the movable bottom rail 33 and the bottom frame member 12 from the state illustrated in FIG. 20A into the state illustrated in FIG. 20D, thus, gradually moving the tip of the pulling member 72 away from the cover member 318 of the first movable glass plate 311.

[0071] Until the abutting piece 75 provided at the tip of the pulling member 72 abuts against the pulling abutment surface 103 of the guide track 100, the tip of the pulling member 72 moves toward the indoor side around one of the slide screws 73 serving as an axial center of the pulling member 72, as illustrated from FIG. 20A to FIG. 20B. During this movement, no external force acts on the movable sash 30, so that the movable sash 30 does not move relative to the opening frame 10. However, the pulling member 72 is prevented from rotating toward the indoor side after the abutting piece 75 has abutted against the pulling abutment surface 103 of the guide track 100. As a result, further rotation of the pulling member 72 around the slide screw 73 causes the movable bottom rail 33 to relatively move toward the outdoor side around a contact point between the pulling abutment surface 103 and the abutting piece 75 of the pulling member 72 serving as an axial center of the movable bottom rail 33. This brings the movable tight material 150 provided on the bottom frame member 12 into the state of being pressed into contact with the peripheral end of the second movable glass plate 312 located at the bottom thereof, as illustrated in FIG. 6.

[0072] As a result of the above-described operations, operating the operating handle 50 in the direction of housing it in the housing depression 35c brings all the four peripheral sides of the movable sash 30 into the state of being pressed into contact with the movable tight materials 150 provided on the opening frame 10 and the fixed sash 20. Thus, the water tightness, heat insulating properties, and sound insulating properties can be improved. As described above, the movable sash 30 is pressed into contact with the movable tight materials 150 by operating the operating handle 50 in the direction of housing it in the housing depression 35c without involving the sliding of the movable sash 30. This eliminates the risk of wear of the movable tight materials 150.

[0073] When the movable sash 30 is to be slid again, moving the operating handle 50 in the direction of projecting from the housing depression 35c moves the movable rails and stiles 32, 33, 34, and 35 of the movable sash 30 toward the indoor side, thus bringing the movable tight materials 150 into the state of being apart from the second movable glass plate 312. Moving the operating handle 50 also positions the tail end engaging pin 81 in the tail end pin insertion hole portion 85a of the tail end cam hole 85 formed in the pulling plate 82, and positions the head end engaging pin 91 in the head end pin insertion hole portion 92a of the head end cam hole 92 formed

in the head end slide member 40C. This enables sliding of the movable sash 30 without applying a large operating force.

[0074] During the operation described above, the movement of the movable sash 30 toward the outdoor side relative to the opening frame 10 causes a reaction force thereof to be applied to the respective slide members 40, the top guide member 60, and the sash rollers 36. However, according to the above-described fitting, the cover members 318 are provided at places located on the outdoor sides of the top, the bottom, and the head end slide members 40A, 40B, and 40C. As a result, the cover members 318 prevent the top, the bottom, and the head end slide members 40A, 40B, and 40C from moving toward the outdoor side. For the tail end slide member 40D, the slide rollers 84 are provided on the pulling plate 82 connected to the tail end slide member 40D, and abut on the slide plate 85 provided on the movable tail end stile 35. As a result, the pulling plate 82, the slide rollers 84, and the slide plate 86 cooperate to prevent the tail end slide member 40D from moving toward the outdoor side. As a result of these arrangements, the movement of the movable sash 30 toward the outdoor side does not cause a problem such as the slide members 40 being pressed into contact with the slide grooves 32b, 33b, 34b, and 35b, and the operating handle 50 can be operated without requiring a large operating force.

[0075] The top guide member 60 is made such that both ends of the guide arm 61 are provided with the two respective guide rollers 62, which in turn abut on the respective top guide surfaces 121 of the top guide groove 120 provided on the top frame member 11. This allows the guide member 60 to resist the above-mentioned reaction force without causing a problem in the sliding of the movable sash 30. Furthermore, the sash rollers 36 are directly supported by the movable bottom rail 33, and the guide track 100 having the inclined surfaces 102 is used. As a result, the sash rollers 36 and the movable sash 30 move toward the outdoor side while slightly moving upward along one of the inclined surfaces 102, and hence need not resist the above-mentioned reaction force. This allows the movable sash 30 to smoothly slide without causing a problem of applying a large reaction force to axles of the sash rollers 36.

[0076] In addition, in the fitting described above, the fixed multi-layered planar material 21 having the two layers of heat-insulating spaces 215 and 217 is used in the fixed sash 20, and the movable multi-layered planar material 31 having the two layers of heat-insulating spaces 315 and 317 is used in the movable sash 30. Moreover, as illustrated in FIGS. 4 and 6, the first glass plates 211 and 311 cover the thickness-direction-facing surfaces located on the outdoor sides of the head end stiles 24 and 34, the top rails 22 and 32, and the bottom rails 23 and 24 of the sashes 20 and 30, respectively. As a result, the heat-insulating spaces 215 and 315 lie between the second glass plates 212 and 312, respectively, and the thickness-direction-facing surfaces. This prevents the head

end stiles 24 and 34, the top rails 22 and 32, and the bottom rails 23 and 24 from acting as heat bridges between the outdoor space and the indoor space, which is very advantageous in terms of the heat insulating properties. Furthermore, the third glass plates 213 and 313 located on the indoor side are formed to have smaller vertical and transverse dimensions than those of the first glass plates 211 and 311. This can prevent a problem of increase in the dimension in the thickness direction when the first glass plates 211 and 311 and the second glass plates 212 and 312 cover the thickness-direction-facing surfaces on the outdoor side. While the meeting part cover member 221 is provided at the outer peripheral end of the fixed tail end stile 25 so as to cover the end face of the fixed tail end stile 25 and the end faces of the three fixed glass plates 211, 212, and 213, the meeting part cover member 221 is unlikely to act as a heat bridge to impair the heat insulating properties because the movable tail end stile 35 of the movable sash 30 is disposed on the indoor side. While a stile having a portion covering the end faces of the three movable glass plates 311, 312, and 313 is used as the movable tail end stile 35, the movable tail end stile 35 is unlikely to act as a heat bridge to impair the heat insulating properties because the fixed tail end stile 25 of the fixed sash 20 is disposed on the outdoor side.

[0077] While the embodiment described above illustrates the single sliding window, the embodiment can be applied to, for example, a double sliding window, provided that a sash or sashes slides or slide relative to an opening frame. While the multi-layered glass is used as the planar material, the planar material need not be multi-layered.

[0078] In the embodiment described above, the tail end orthogonal pulling mechanism 80 is provided between the movable tail end stile 35 of the movable sash 30 and the fixed vertical frame 13, and the head end orthogonal pulling mechanism 90 is provided between the movable head end stile 34 and the head end vertical frame 14. However, the present invention need not provide the two orthogonal pulling mechanisms, but only needs to provide one of them.

[0079] According to the embodiment of the present invention, sliding a slide member by operating the operating handle causes the pulling member to abut on the thickness-direction-facing surface of a frame member, and thereby moves the entire sash in the thickness direction thereof on the guide surface relative to the opening frame. This eliminates the necessity of configuring the sash such that a rail or stile member and the rolling bodies can move relative to each other. Thus, the water tightness, the heat insulating properties, and the sound insulating properties can be improved without causing the structural complexity or causing a large reaction force to be applied to the part supporting the rolling bodies.

[0080] Although the invention has been described with respect to specific embodiments for a complete and clear disclosure, the appended claims are not to be thus limited

but are to be construed as embodying all modifications and alternative constructions that may occur to one skilled in the art that fairly fall within the basic teaching herein set forth.

Claims

1. A fitting in which a sash is provided slidably along a longitudinal direction of a rail or stile member by rolling a rolling body provided on the rail or stile member on a guide surface along a thickness direction surface of a frame member, the fitting comprising:

a slide member provided on the rail or stile member and configured to slide in the longitudinal direction of the rail or stile member;
an operating handle provided on the sash and configured to slide the slide member relative to the rail or stile member when operated;
a pulling member configured to move along a thickness direction of the rail or stile member; and
a drive mechanism configured to move the pulling member in the thickness direction of the rail or stile member in accordance with sliding of the slide member, wherein
the sash is configured to be moved in its thickness direction relative to an opening frame by abutting the pulling member on a thickness-direction-facing surface of the frame member.

2. The fitting according to claim 1, wherein the sash includes:

an orthogonal rail or stile member disposed in a direction orthogonal to the rail or stile member; and
an orthogonal slide member configured to slide in a longitudinal direction of the orthogonal rail or stile member and configured to slide in conjunction with the slide member, and
an orthogonal pulling mechanism is interposed between the orthogonal rail or stile member and a thickness direction surface of an orthogonal frame member disposed facing a thickness direction surface of the orthogonal rail or stile member when the sash is closed, the orthogonal pulling mechanism moving the orthogonal rail or stile member in the same direction as that of the rail or stile member in accordance with sliding of the orthogonal slide member.

3. The fitting according to claim 2, wherein the orthogonal pulling mechanism includes:

an engaging pin projecting from the orthogonal frame member toward the thickness direction

5

10

15

20

25

30

35

40

45

50

55

surface of the orthogonal rail or stile member, and having a larger outside diameter at a projecting end thereof than at a base thereof; an engaging inclined surface configured to face the base after the projecting end of the engaging pin has passed when the sash is closed, and configured to move the orthogonal frame member and the orthogonal rail or stile member closer to each other along the thickness direction by abutting on the base when the orthogonal slide member has slid; and
an engaging portion configured to face the projecting end of the engaging pin when the orthogonal frame member and the orthogonal rail or stile member have moved closer to each other, and configured to restrict the sash from sliding toward a direction of opening by engaging with the projecting end.

4. The fitting according to claim 1, wherein the sash includes:

the rolling body on a bottom rail member; a top guide member on a thickness direction surface of a top rail member; and
a top slide member provided slidably along a longitudinal direction of the top rail member and configured to slide in conjunction with the slide member,

a top guide groove having a pair of top guide surfaces along a sash width direction is formed on a frame member facing the top rail member, and the sash is provided so as to be slidable along the longitudinal direction of the top rail member in a state in which the top guide member abuts on the top guide surfaces, and
the top guide member is supported so as to be movable along the thickness direction relative to the top rail member, and a shift mechanism is interposed between the top rail member and the top guide member, the shift mechanism moving the top guide member along the thickness direction relative to the top rail member according to the slide of the top slide member.

FIG.3

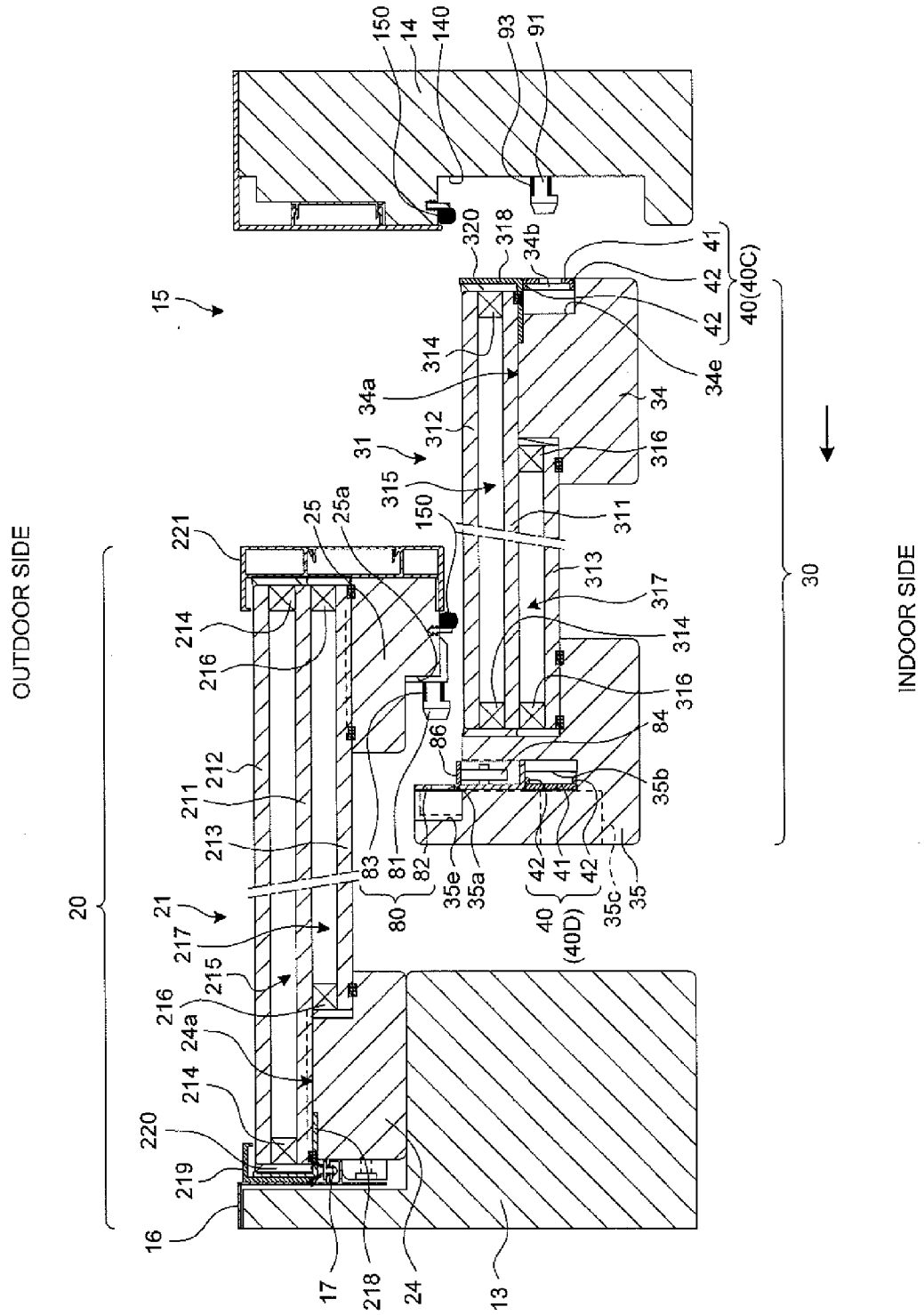

FIG.4

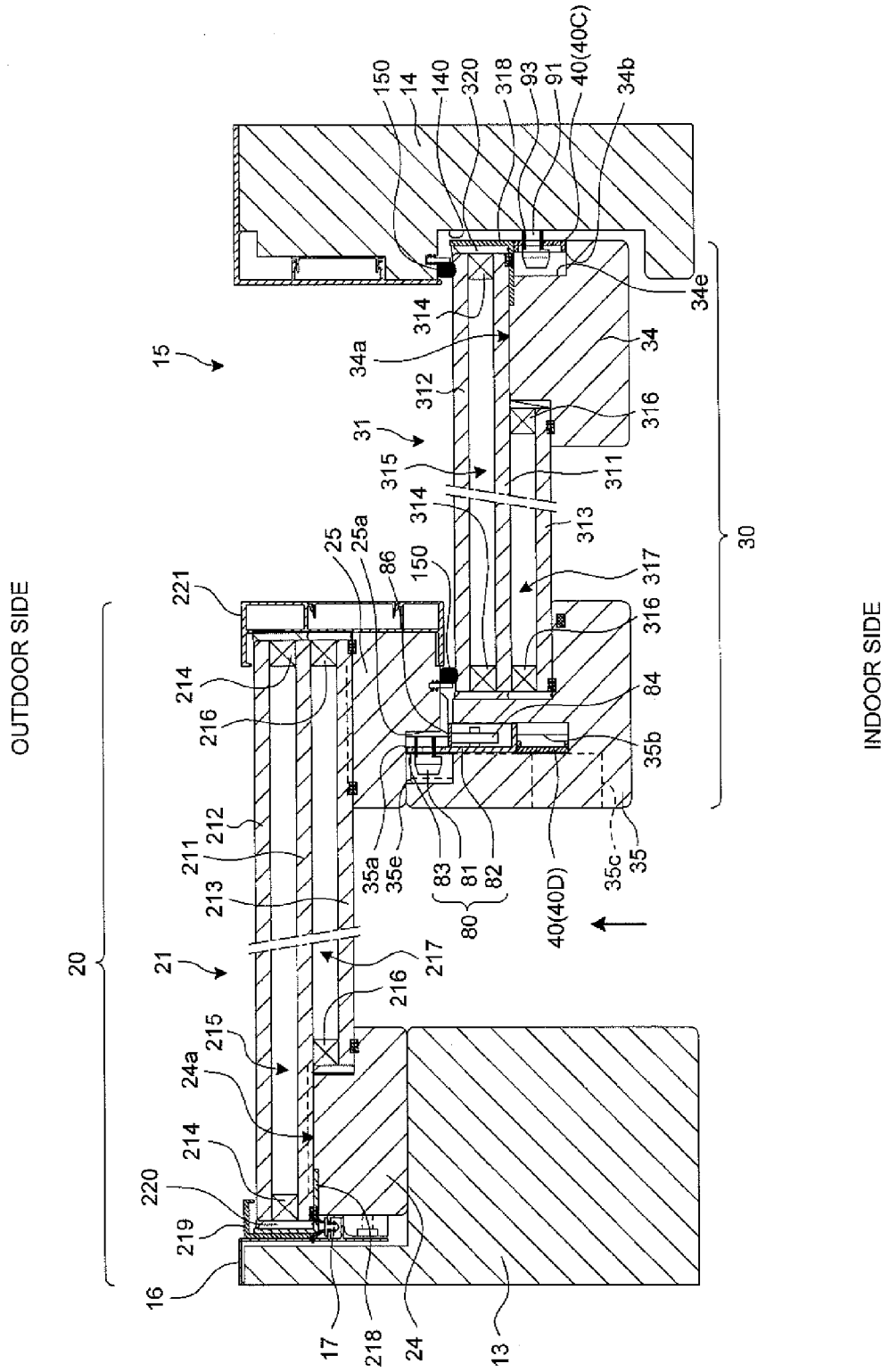

FIG.5

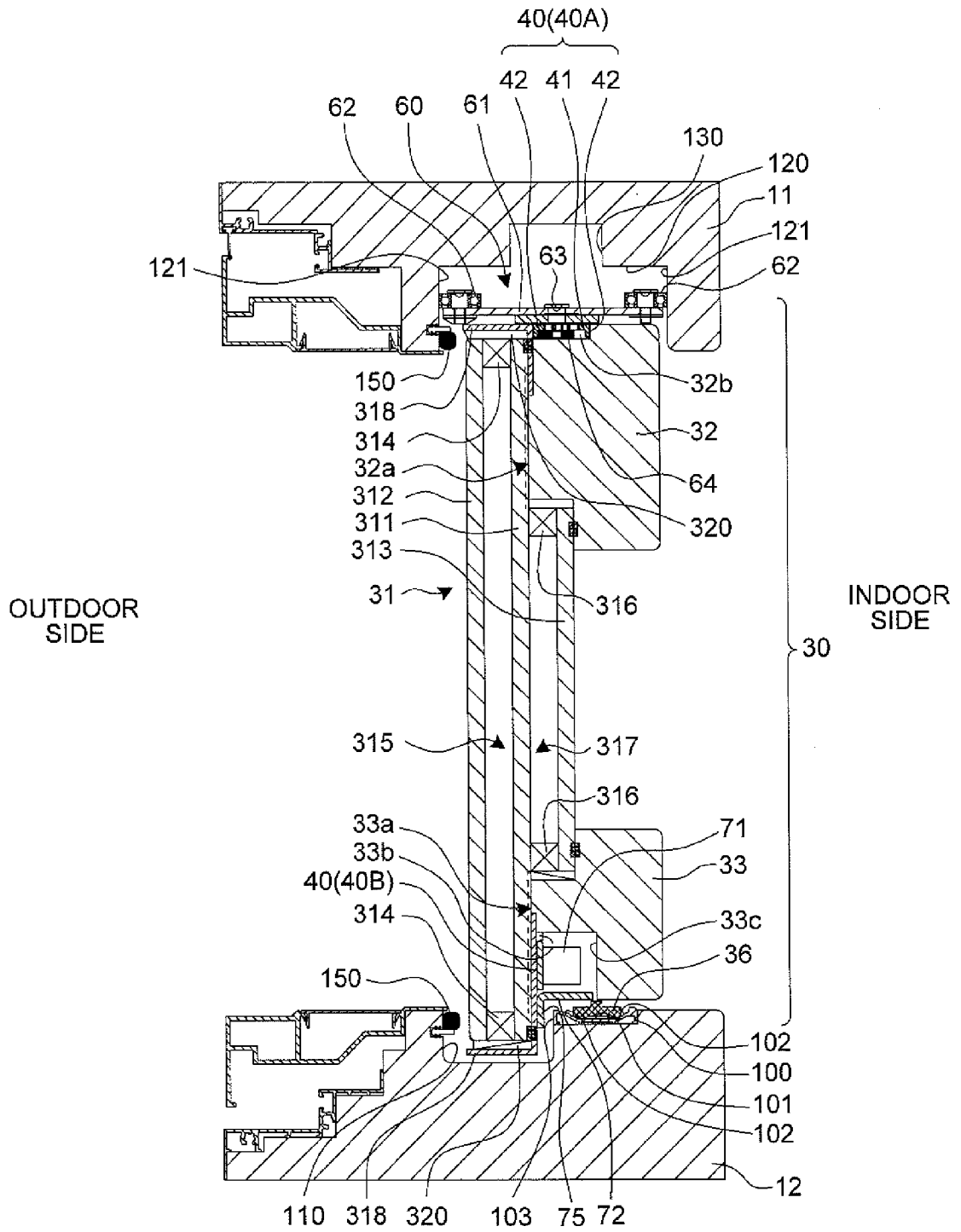

FIG.6

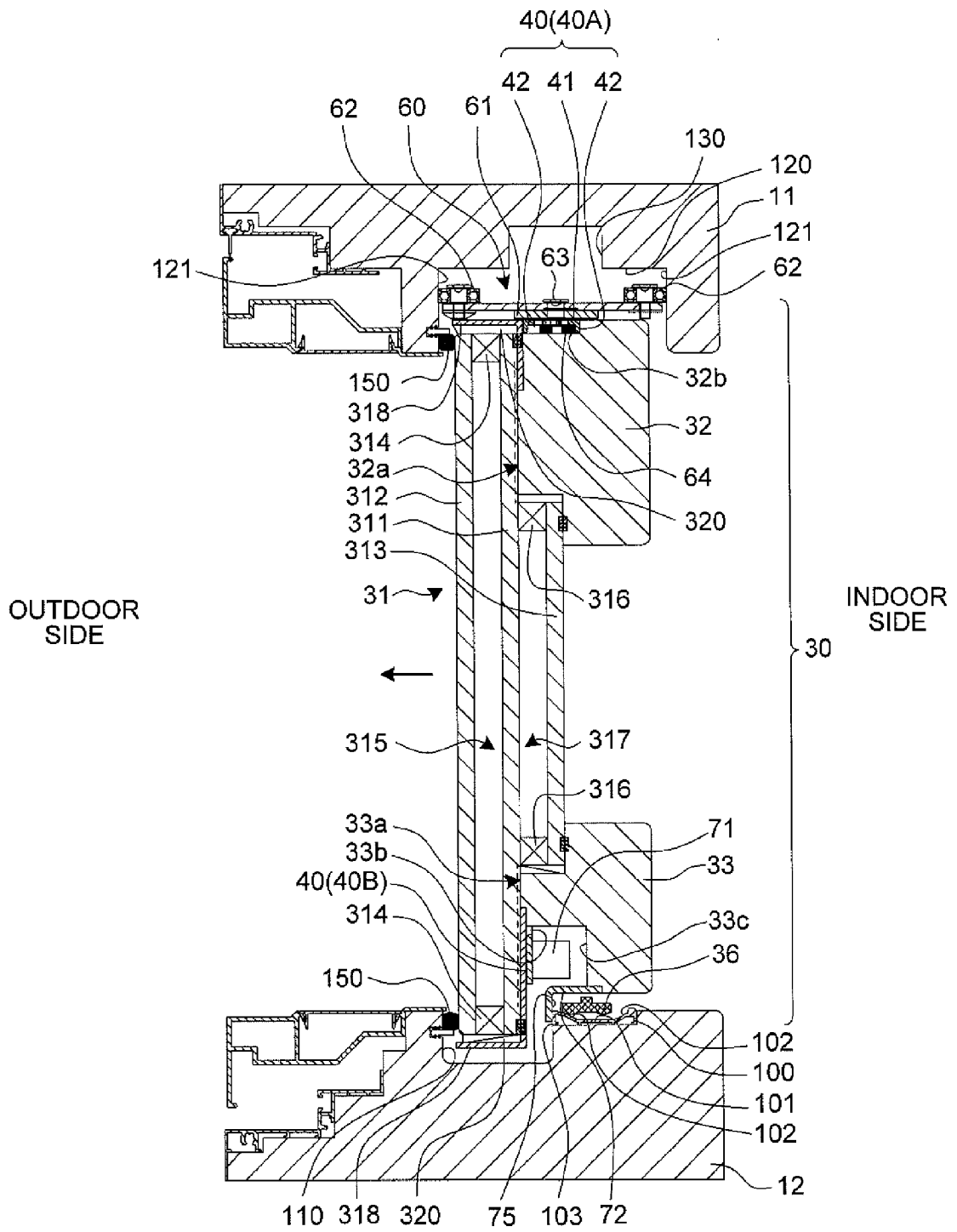

FIG.7

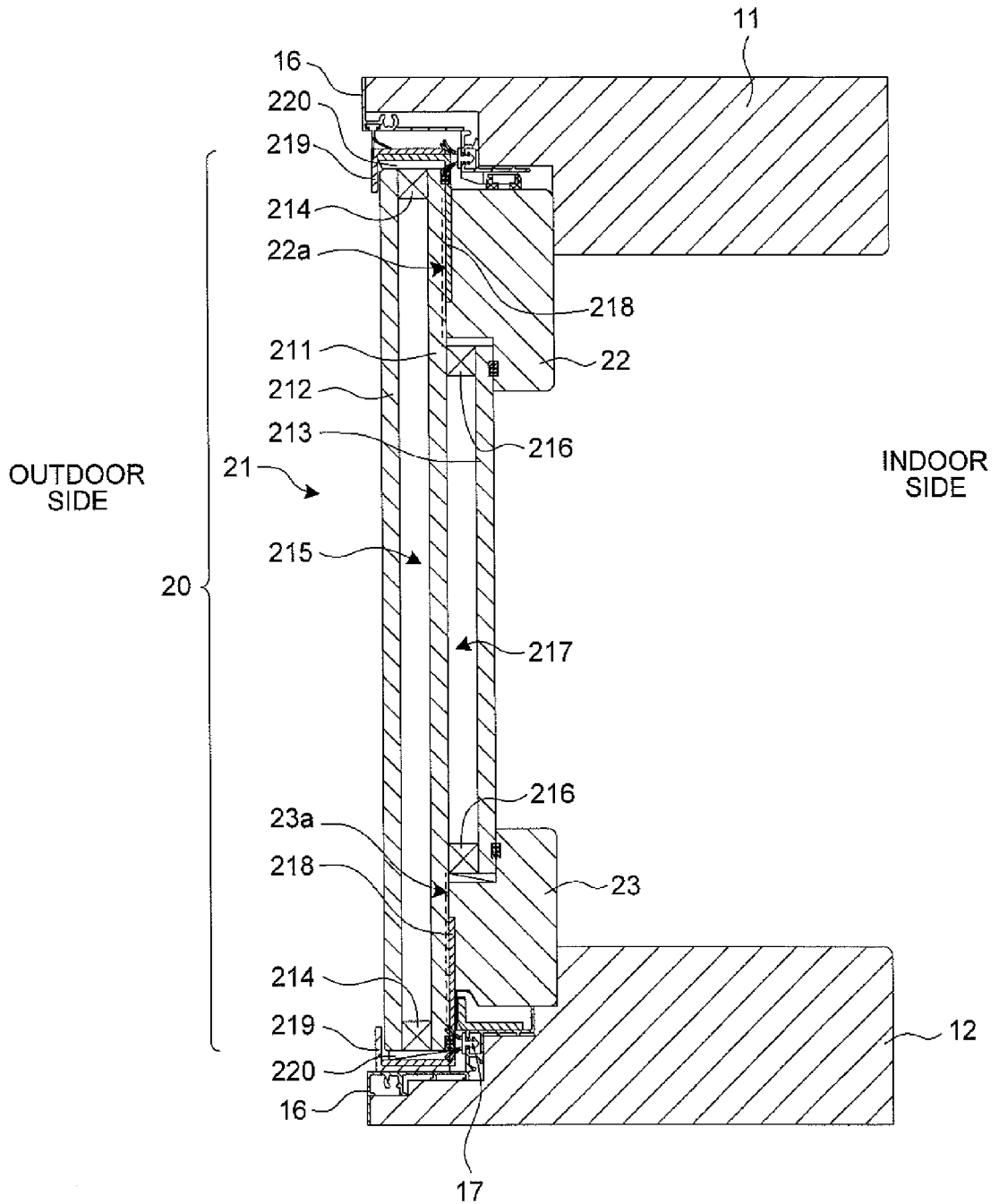

FIG.8

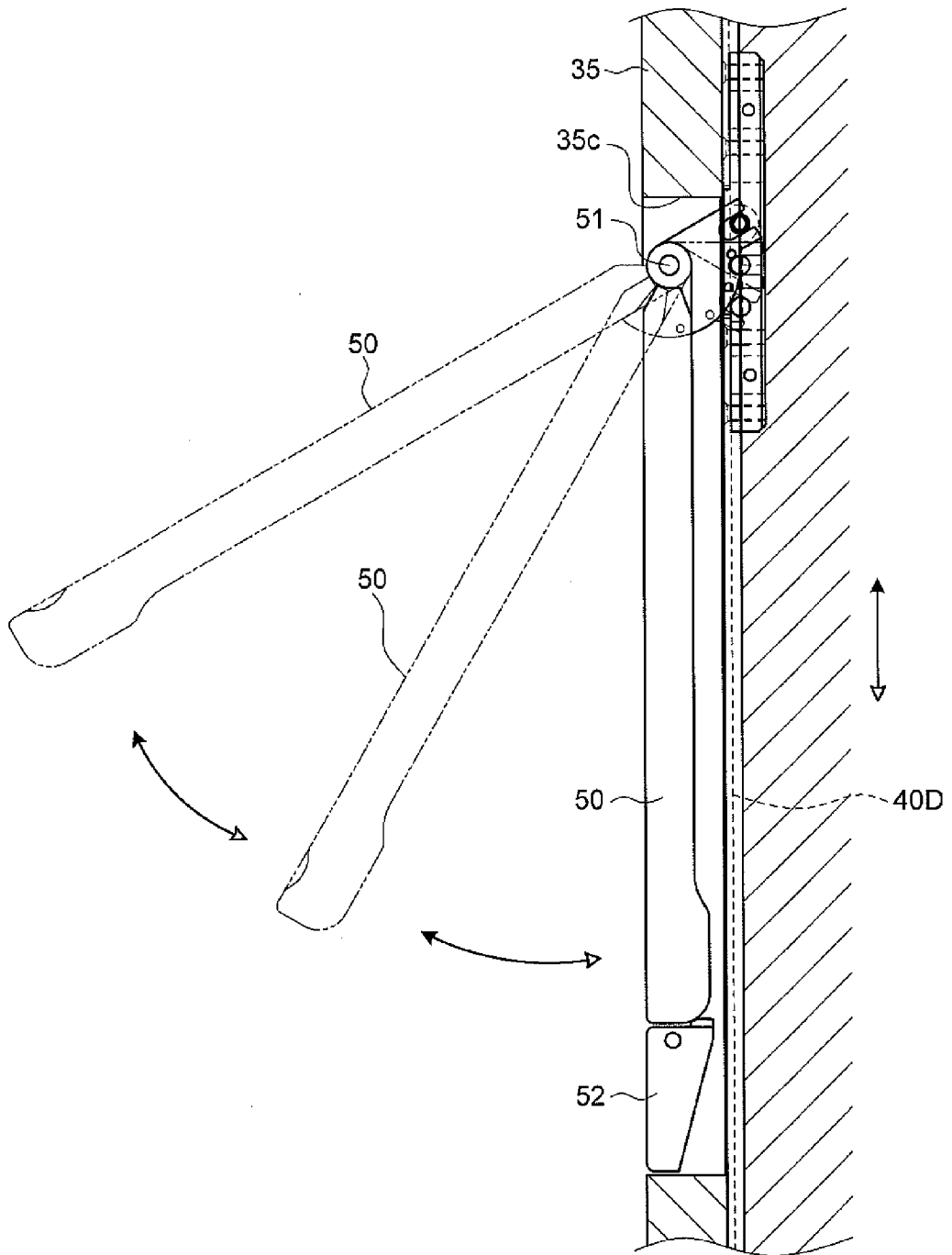

FIG.10

HEAD END SIDE

TAIL END SIDE

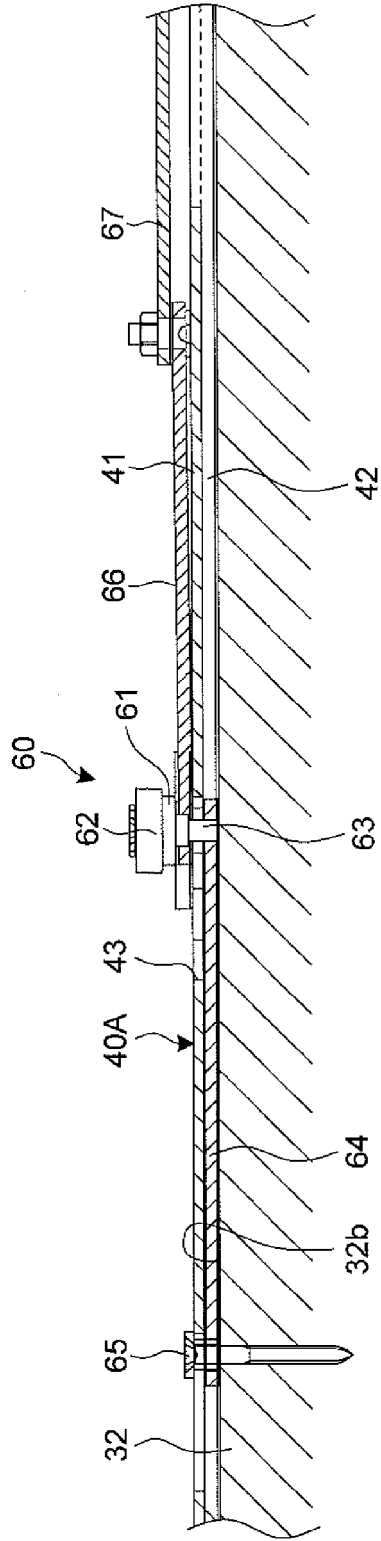

FIG.11

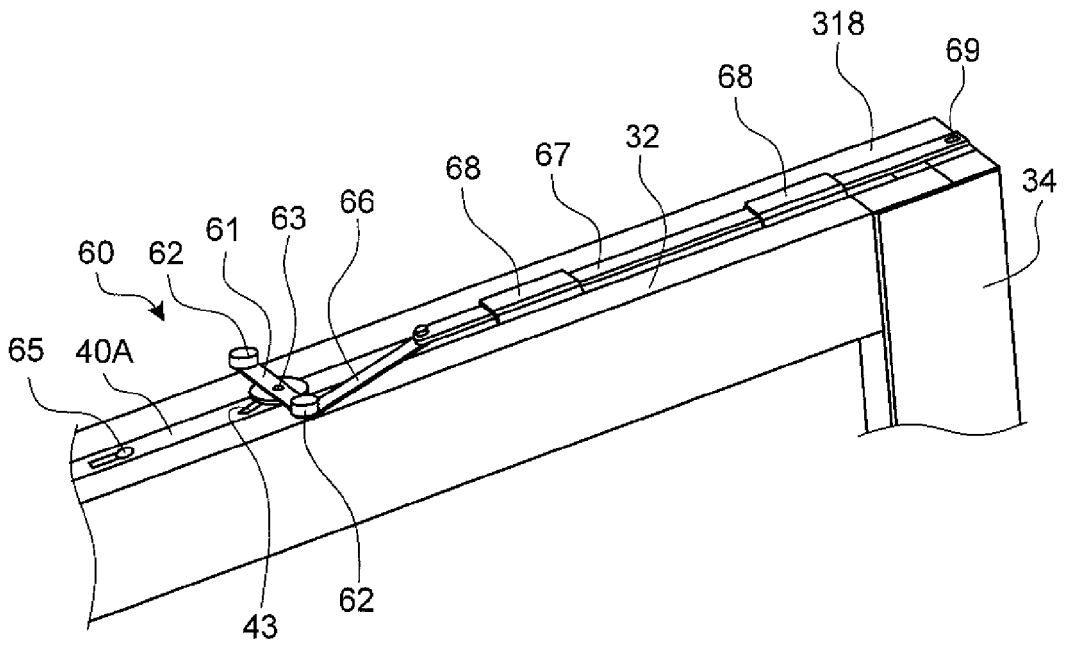

FIG.12

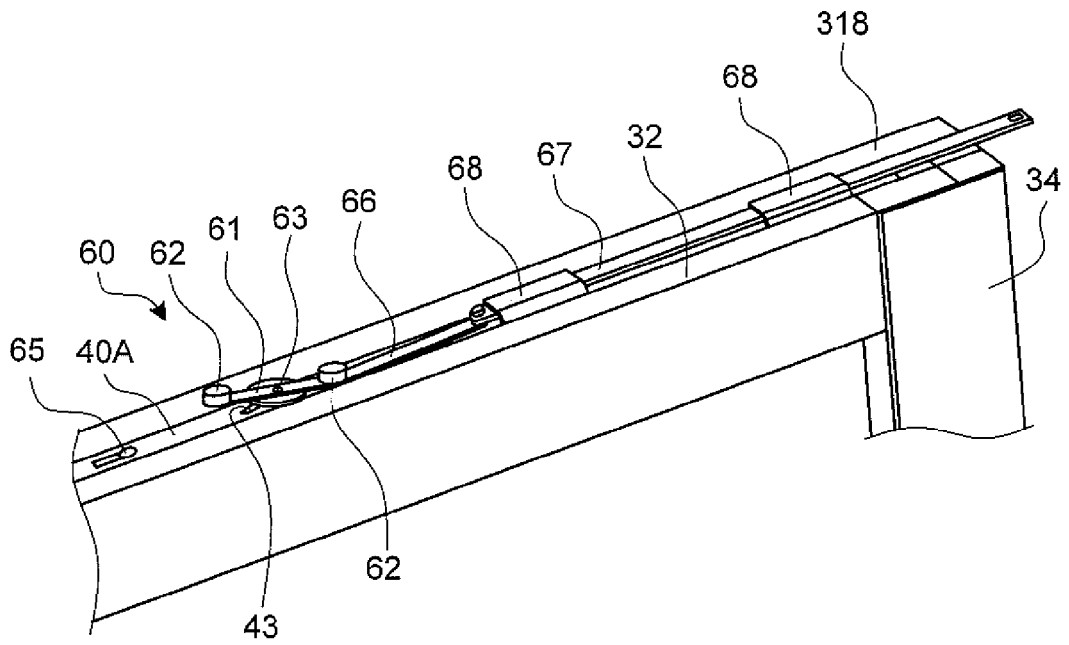

FIG.13

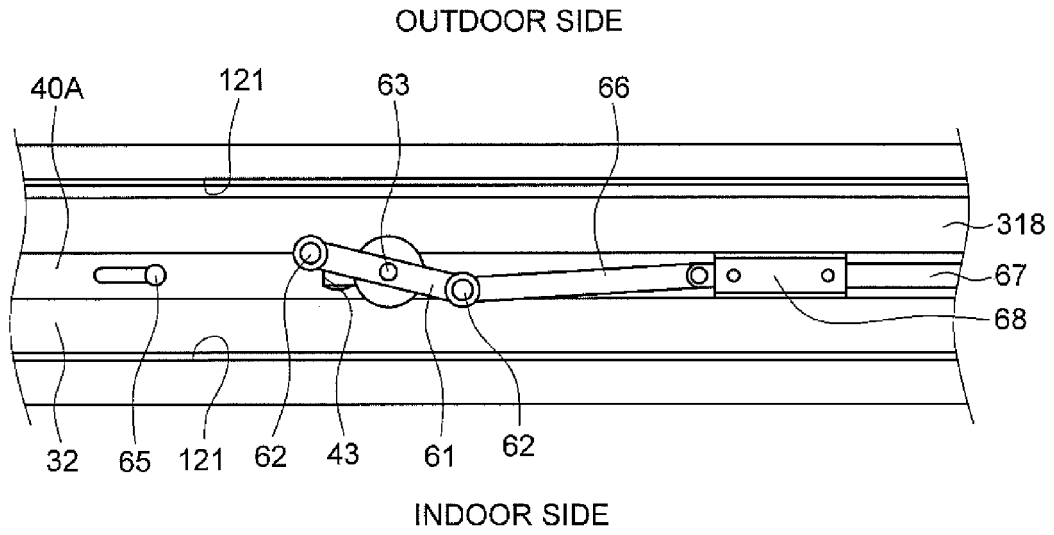

FIG.14

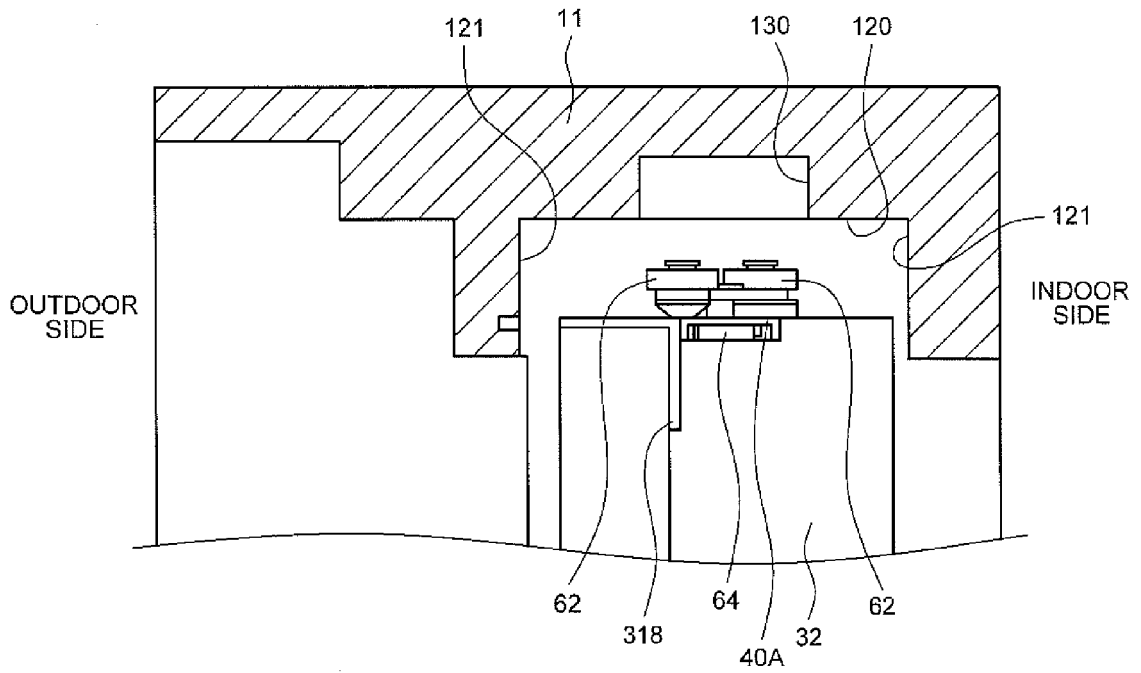

FIG. 15

OUTDOOR SIDE

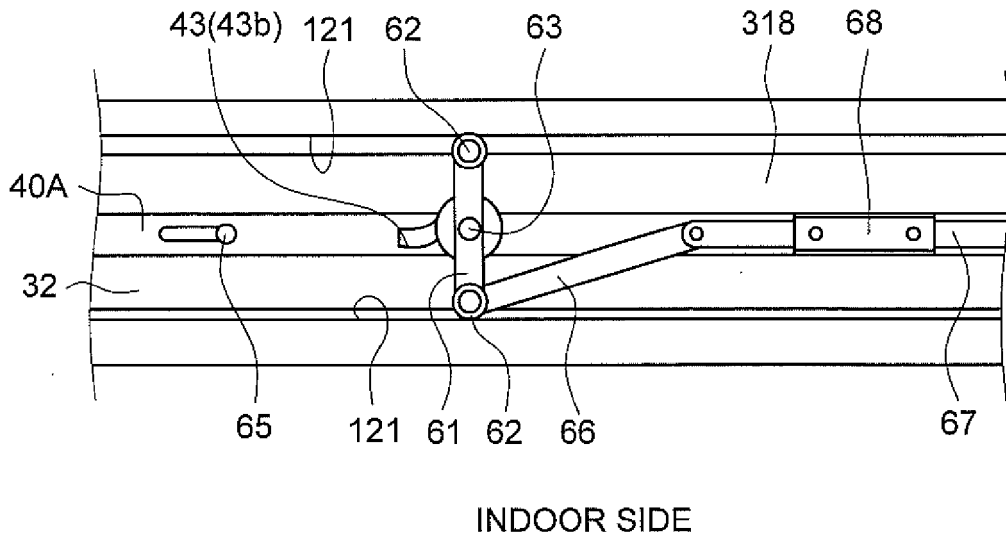

FIG. 16

OUTDOOR SIDE

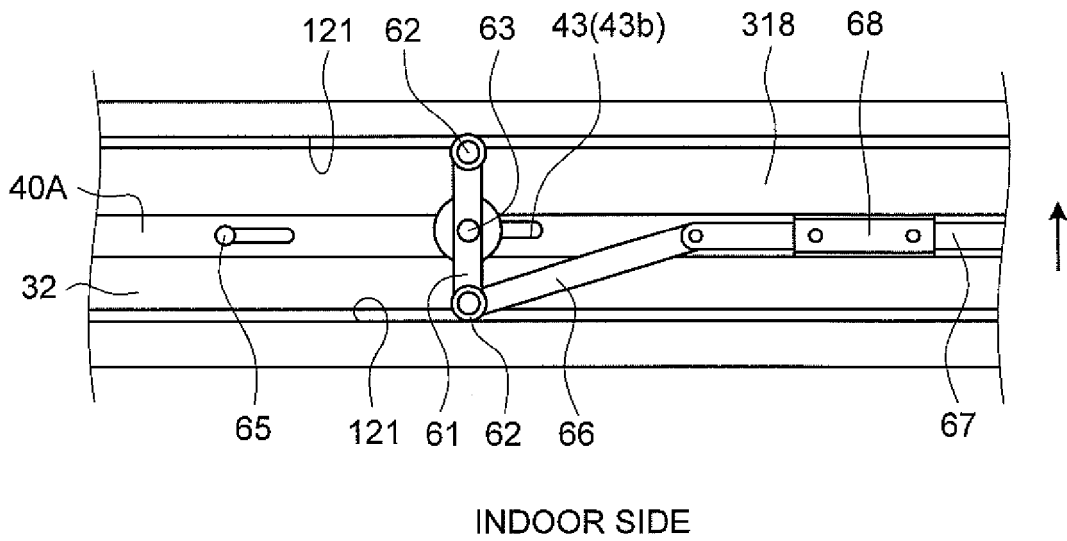

FIG.17

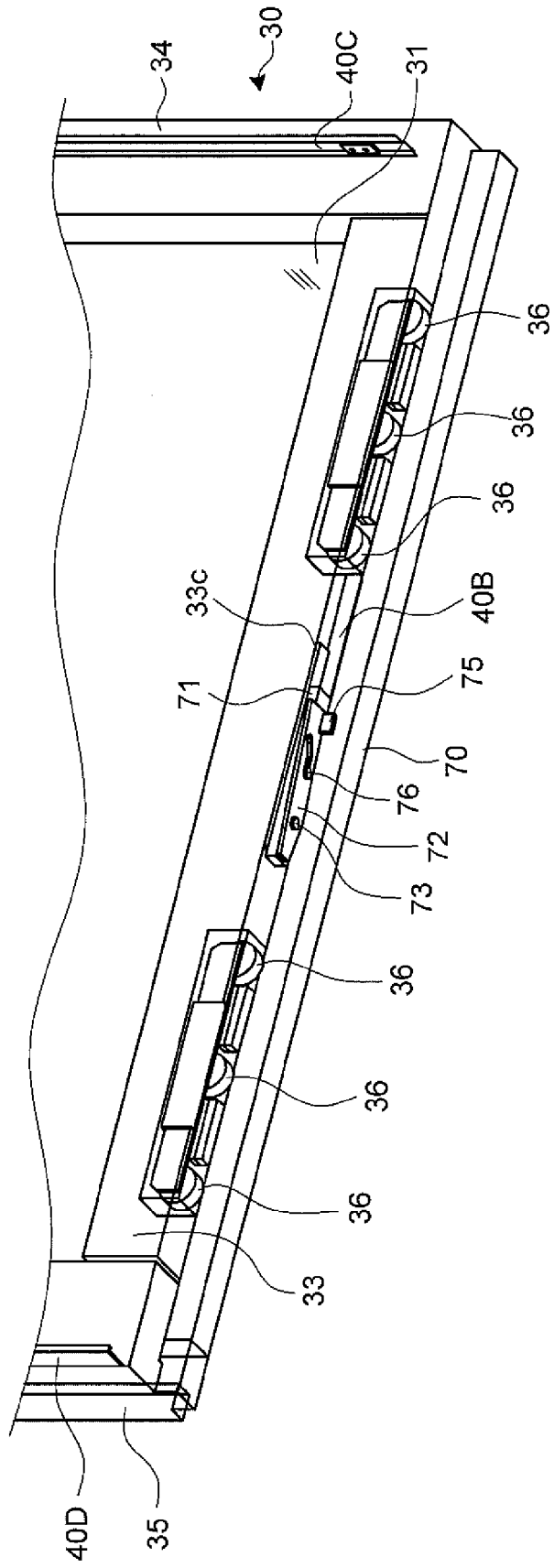

FIG.18

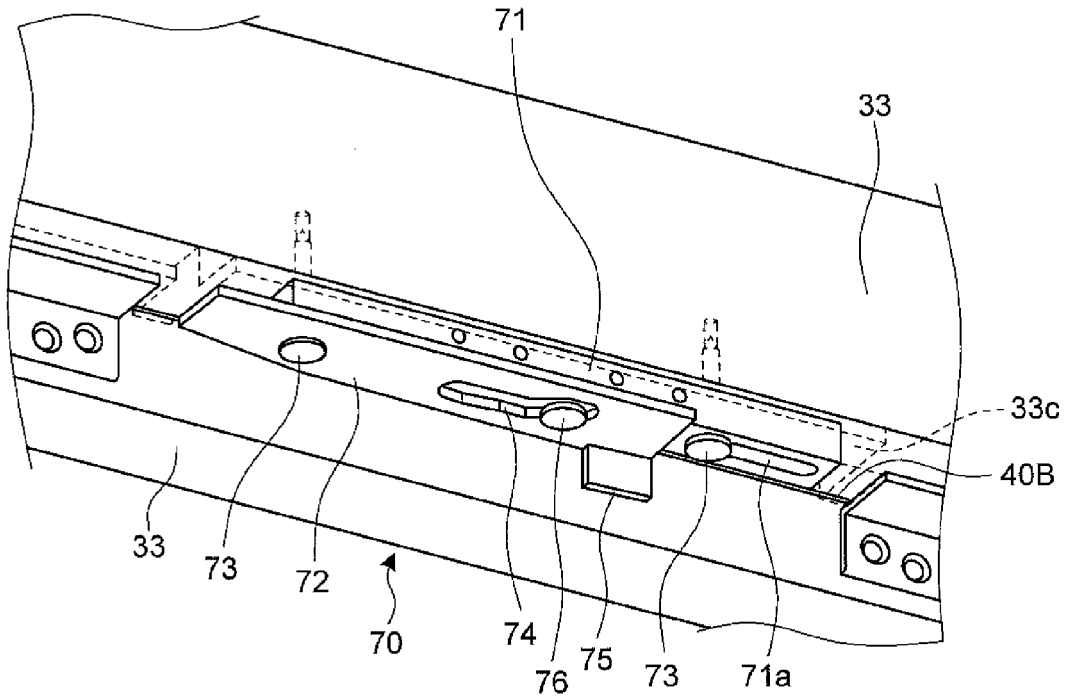

FIG.19

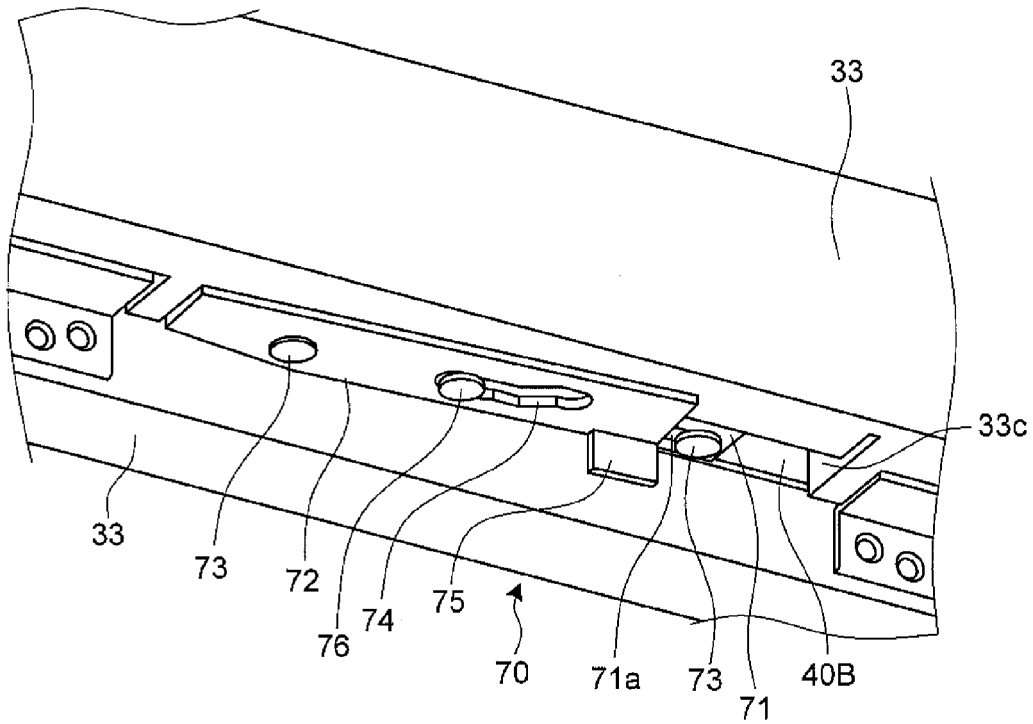

FIG.21

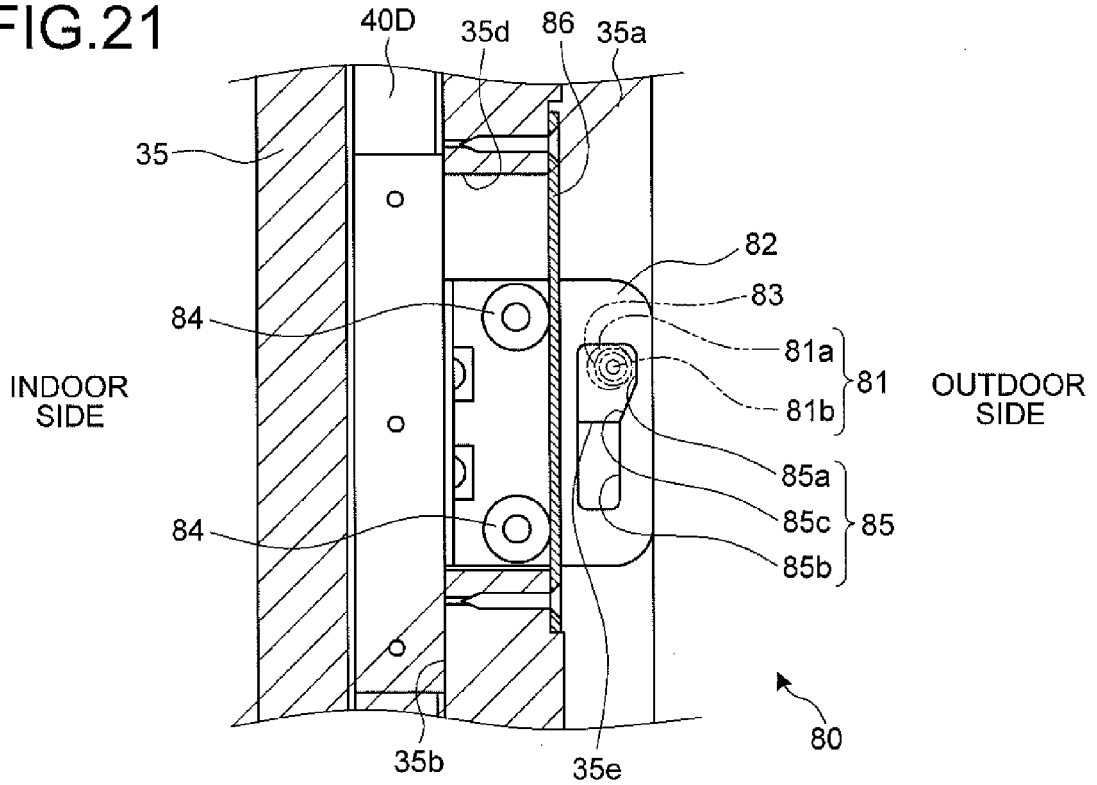

FIG.22

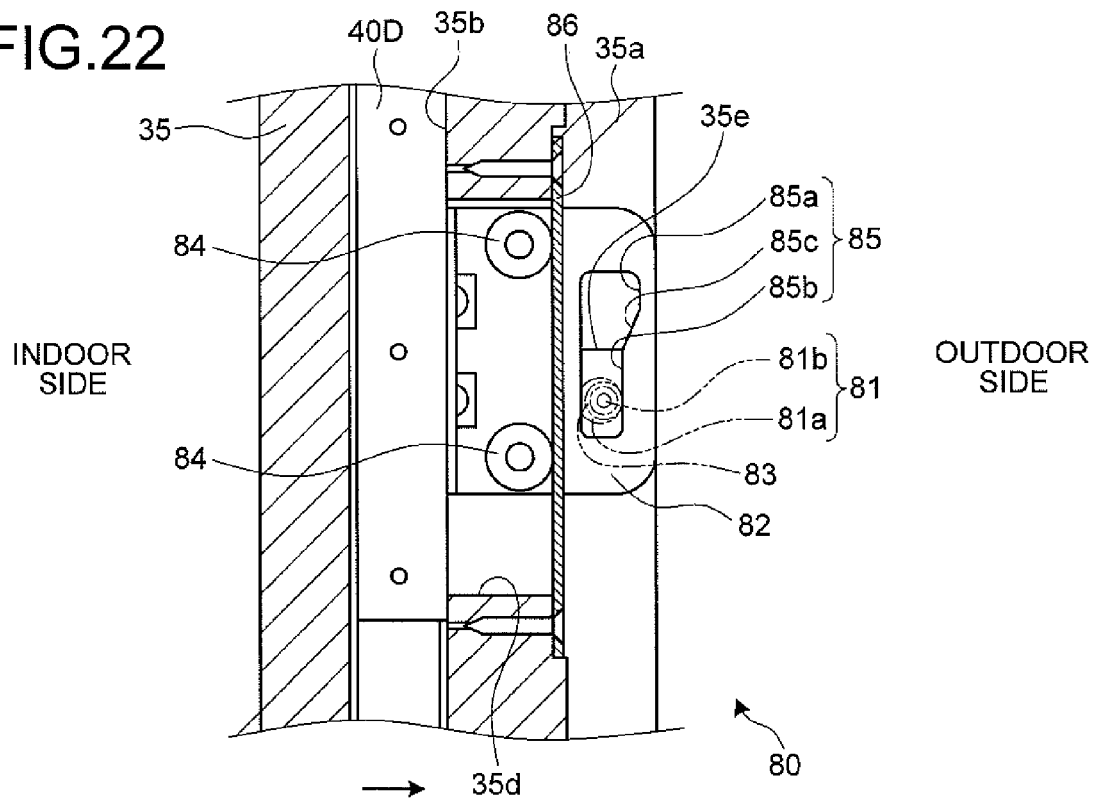

FIG.23

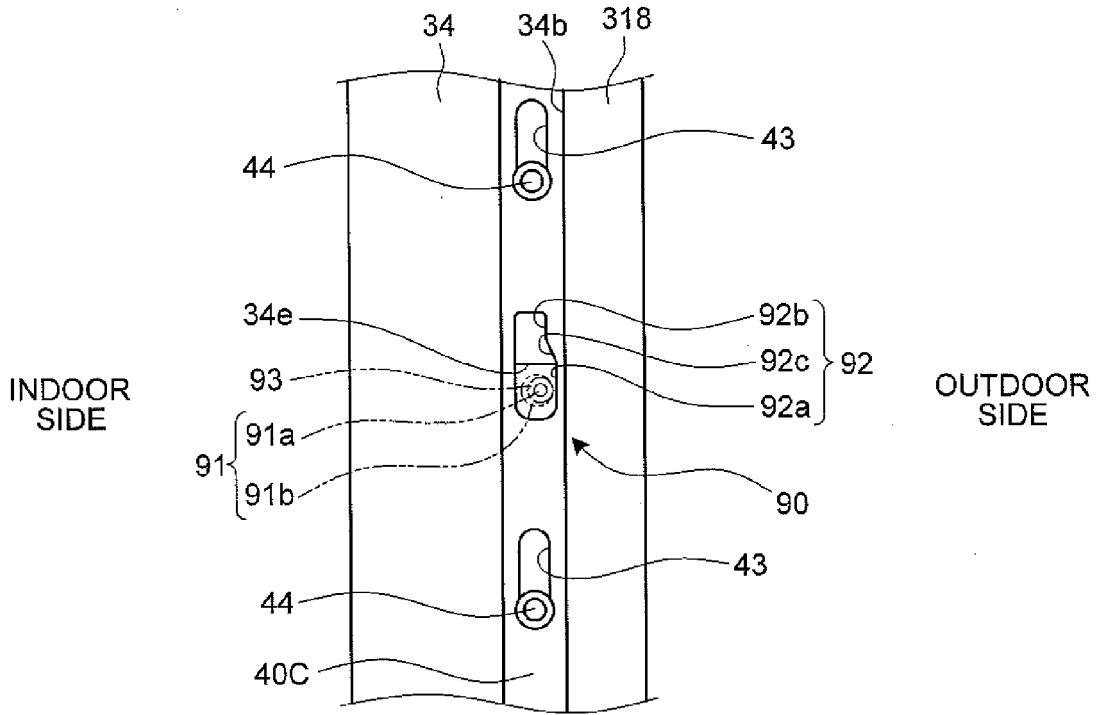
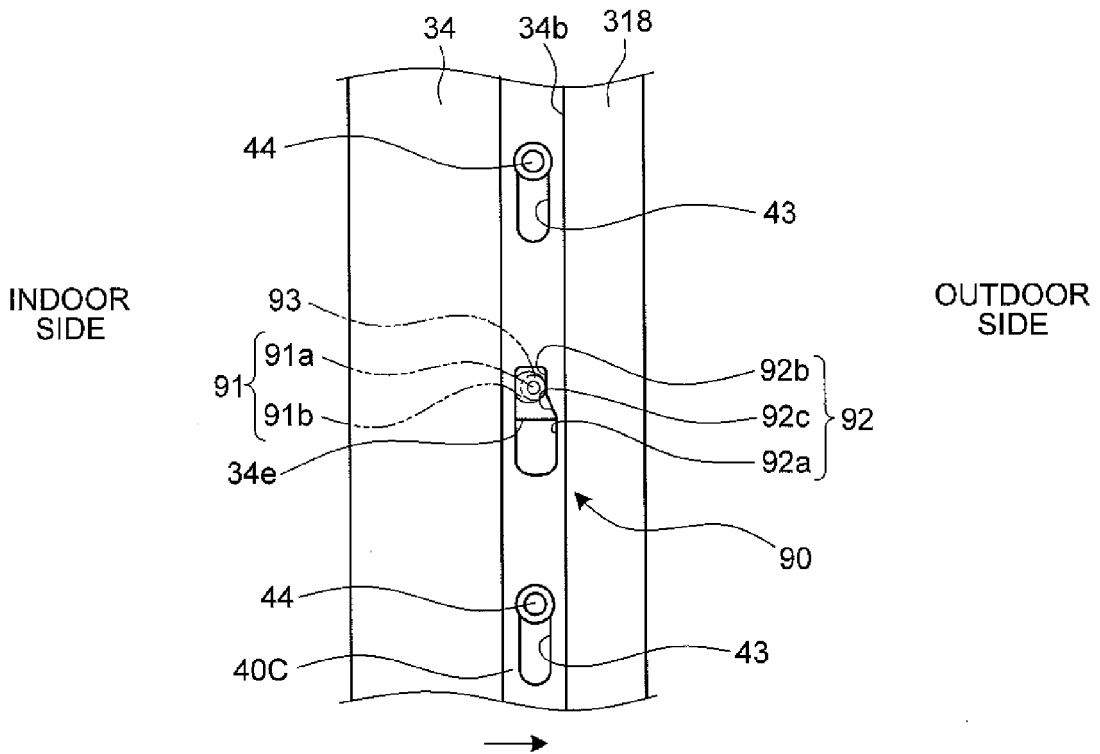

FIG.24





EUROPEAN SEARCH REPORT

Application Number
EP 14 19 2783

5

10

15

20

25

30

35

40

45

50

55

DOCUMENTS CONSIDERED TO BE RELEVANT			
Category	Citation of document with indication, where appropriate, of relevant passages	Relevant to claim	CLASSIFICATION OF THE APPLICATION (IPC)
X	WO 99/60239 A1 (MUSTERS JOHANNES MARIA [NL]) 25 November 1999 (1999-11-25) * page 2, line 35 - page 5, line 20 * * figures 1-5 *	1-4	INV. E05D15/10
X	DE 20 2008 007829 U1 (SIEGENIA AUBI KG [DE]) 21 August 2008 (2008-08-21) * paragraph [0029] - paragraph [0039] * * paragraph [0042] - paragraph [0043] * * figures 1-12 *	1,4	
			TECHNICAL FIELDS SEARCHED (IPC)
			E05D
The present search report has been drawn up for all claims			
Place of search The Hague		Date of completion of the search 10 August 2015	Examiner Prieto, Daniel
CATEGORY OF CITED DOCUMENTS X : particularly relevant if taken alone Y : particularly relevant if combined with another document of the same category A : technological background O : non-written disclosure P : intermediate document		T : theory or principle underlying the invention E : earlier patent document, but published on, or after the filing date D : document cited in the application L : document cited for other reasons & : member of the same patent family, corresponding document	

1
EPO FORM 1503 03/82 (P04C01)

**ANNEX TO THE EUROPEAN SEARCH REPORT
ON EUROPEAN PATENT APPLICATION NO.**

EP 14 19 2783

5

This annex lists the patent family members relating to the patent documents cited in the above-mentioned European search report. The members are as contained in the European Patent Office EDP file on
The European Patent Office is in no way liable for these particulars which are merely given for the purpose of information.

10-08-2015

10

Patent document cited in search report	Publication date	Patent family member(s)	Publication date
WO 9960239 A1	25-11-1999	AT 222317 T	15-08-2002
		AU 3960199 A	06-12-1999
		DE 69902528 D1	19-09-2002
		DE 69902528 T2	26-06-2003
		EP 1080291 A1	07-03-2001
		NL 1009220 C2	24-11-1999
		WO 9960239 A1	25-11-1999

DE 202008007829 U1	21-08-2008	DE 202008007829 U1	21-08-2008
		EP 2283197 A1	16-02-2011
		WO 2009149768 A1	17-12-2009

15

20

25

30

35

40

45

50

55

EPO FORM P0469

For more details about this annex : see Official Journal of the European Patent Office, No. 12/82

REFERENCES CITED IN THE DESCRIPTION

This list of references cited by the applicant is for the reader's convenience only. It does not form part of the European patent document. Even though great care has been taken in compiling the references, errors or omissions cannot be excluded and the EPO disclaims all liability in this regard.

Patent documents cited in the description

- JP 2014055454 A [0001]
- JP 2009522470 A [0004] [0005]