



(11) **EP 2 975 164 A3**

(12) **EUROPEAN PATENT APPLICATION**

(88) Date of publication A3:
10.02.2016 Bulletin 2016/06

(51) Int Cl.:
D01H 13/04 (2006.01) D02G 3/36 (2006.01)

(43) Date of publication A2:
20.01.2016 Bulletin 2016/03

(21) Application number: **15162355.0**

(22) Date of filing: **02.04.2015**

(84) Designated Contracting States:
AL AT BE BG CH CY CZ DE DK EE ES FI FR GB GR HR HU IE IS IT LI LT LU LV MC MK MT NL NO PL PT RO RS SE SI SK SM TR
Designated Extension States:
BA ME
Designated Validation States:
MA

(71) Applicant: **Murata Machinery, Ltd.**
Kyoto-shi, Kyoto 601-8326 (JP)
(72) Inventor: **Shiota, Takeshi**
Kyoto 612-8686 (JP)
(74) Representative: **Weickmann & Weickmann**
Maximilianstrasse 4b
82319 Starnberg (DE)

(30) Priority: **13.06.2014 JP 2014122178**

(54) **CORE YARN SUPPLYING UNIT, CORE YARN SUPPLYING DEVICE, AND SPINNING MACHINE**

(57) A core yarn supplying unit (50) adapted to supply a core yarn (c) includes a tension applying section (60) adapted to apply a tension to the core yarn (C); and a core yarn feeding section (90) adapted to feed the core yarn (C) towards a front top roller 19a, wherein a feeding path of the core yarn (C) in the core yarn feeding section (90) is arranged on a straight line connecting an inlet region and an outlet region of the feeding path.

FIG. 8

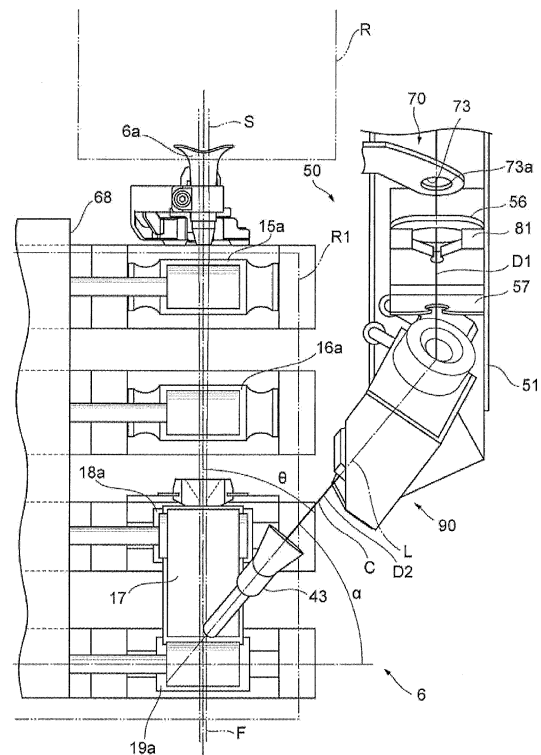

EP 2 975 164 A3



EUROPEAN SEARCH REPORT

Application Number
EP 15 16 2355

5

10

15

20

25

30

35

40

45

50

55

DOCUMENTS CONSIDERED TO BE RELEVANT			
Category	Citation of document with indication, where appropriate, of relevant passages	Relevant to claim	CLASSIFICATION OF THE APPLICATION (IPC)
X	EP 1 801 271 A1 (MURATA MACHINERY LTD [JP]) 27 June 2007 (2007-06-27) * paragraphs [0029] - [0041], [0043] - [0050]; figures 1,2 *	1,2,4-9	INV. D01H13/04 D02G3/36
X	US 2002/139102 A1 (KAWABATA HIRAYUKI [JP]) 3 October 2002 (2002-10-03) * paragraphs [0043], [0044], [0056] - [0062], [0095] - [0100]; figures 1-4 *	1,2,4-9	
X	EP 1 184 495 A2 (MURATA MACHINERY LTD [JP]) 6 March 2002 (2002-03-06) * paragraphs [0029], [0041] - [0044]; figures 1,6 *	1-9	
X	DE 196 42 222 A1 (ZINSER TEXTILMASCHINEN GMBH [DE]) 16 April 1998 (1998-04-16) * column 3, line 24 - column 4, line 4; figure 1 *	1,4,6-9	
			TECHNICAL FIELDS SEARCHED (IPC)
			D01H D02G
The present search report has been drawn up for all claims			
Place of search Munich		Date of completion of the search 5 January 2016	Examiner Wendl, Helen
CATEGORY OF CITED DOCUMENTS X : particularly relevant if taken alone Y : particularly relevant if combined with another document of the same category A : technological background O : non-written disclosure P : intermediate document		T : theory or principle underlying the invention E : earlier patent document, but published on, or after the filing date D : document cited in the application L : document cited for other reasons & : member of the same patent family, corresponding document	

EPO FORM 1503 03.02 (P04C01)

ANNEX TO THE EUROPEAN SEARCH REPORT
ON EUROPEAN PATENT APPLICATION NO.

EP 15 16 2355

5

This annex lists the patent family members relating to the patent documents cited in the above-mentioned European search report.
The members are as contained in the European Patent Office EDP file on
The European Patent Office is in no way liable for these particulars which are merely given for the purpose of information.

05-01-2016

10

Patent document cited in search report	Publication date	Patent family member(s)	Publication date	
EP 1801271	A1	27-06-2007	CN 101018900 A	15-08-2007
			EP 1801271 A1	27-06-2007
			JP 4529977 B2	25-08-2010
			WO 2006030661 A1	23-03-2006

US 2002139102	A1	03-10-2002	CN 1379131 A	13-11-2002
			US 2002139102 A1	03-10-2002

EP 1184495	A2	06-03-2002	CN 1342793 A	03-04-2002
			DE 60110981 D1	30-06-2005
			DE 60110981 T2	27-04-2006
			EP 1184495 A2	06-03-2002
			JP 4062869 B2	19-03-2008
			JP 2002069760 A	08-03-2002
			US 2002026781 A1	07-03-2002

DE 19642222	A1	16-04-1998	NONE	

15

20

25

30

35

40

45

50

55

EPO FORM/ P0459

For more details about this annex : see Official Journal of the European Patent Office, No. 12/82