



(12) **EUROPEAN PATENT APPLICATION**

(43) Date of publication:
17.02.2016 Bulletin 2016/07

(51) Int Cl.:
B65H 19/22 (2006.01)

(21) Application number: **15176363.8**

(22) Date of filing: **10.07.2015**

(84) Designated Contracting States:
AL AT BE BG CH CY CZ DE DK EE ES FI FR GB GR HR HU IE IS IT LI LT LU LV MC MK MT NL NO PL PT RO RS SE SI SK SM TR
 Designated Extension States:
BA ME
 Designated Validation States:
MA

(72) Inventors:
 • **TREZZI, Roberto**
20025 Legnano (Milano) (IT)
 • **TONIATO, Maurizio**
21012 Cassano Magnago (Varese) (IT)

(74) Representative: **Petruzziello, Aldo**
Racheli S.r.l.
Viale San Michele del Carso, 4
20144 Milano (IT)

(30) Priority: **15.07.2014 IT MI20141288**

(71) Applicant: **Mobert S.r.l.**
21053 Castellanza VA (IT)

(54) **DEVICE FOR WINDING ROLLS WITH AND WITHOUT CORR**

(57) An improved device (10) for the winding of rolls with and without core, especially suitable for the winding of a film (50) for plastic bags, applied to a rotation turret or head (33) of an apparatus or machine for winding (7) and comprising pairs of opposite grippers (11, 13) longitudinally developed, co-axially and symmetrically arranged with respect to a vertical plane and longitudinally developed, coaxially and symmetrically arranged with respect to a vertical plane and each with one of the two ends (20) apt to allow the hooking to a structure for moving said grippers in an axial sliding with respect to a guide bushing (22) and to at least one support flange (34) attached with respect to the apparatus or machine for wind-

ing (7) and coaxial one to the other, with the guide bushing (22) arranged between said support structure (20) and said support flange (34), the pairs of grippers comprising each one an upper gripper (12, 16) and a lower gripper (14, 18) opposite one to the other, with said pairs of grippers provided with a fixed tongue (24) suitable for coupling with the exterior of a core (46) and for hooking the film (50) for driving the same, said device likewise comprising mobile means with magnetic drive apt to couple with at least one further core (46) fitted on the same pair of grippers for the hooking and the driving of a further film (50) to be wound into a roll.

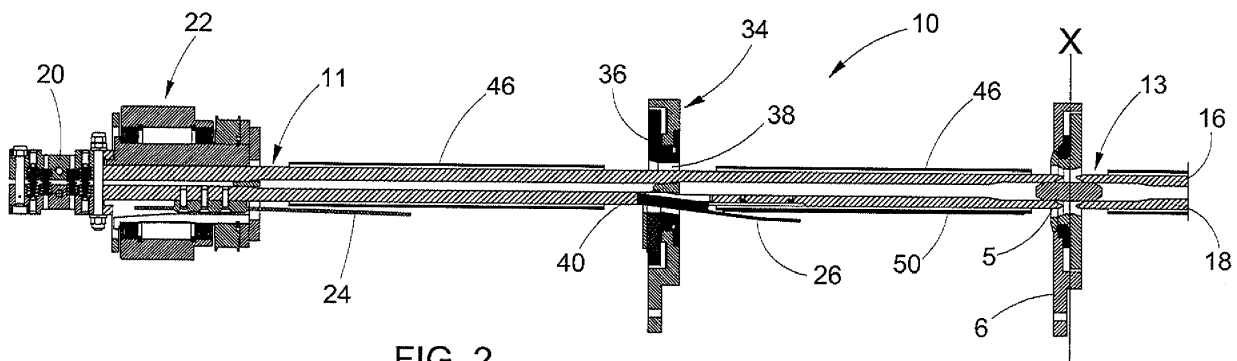

FIG. 2

Description

[0001] The present invention relates to an improved device for winding rolls with and without core.

[0002] More particularly the present invention relates to a device applied to an apparatus or machine for the production of rolls and such as to make the apparatus or machine highly flexible to allow both the creation of rolls provided with a central core in cardboard or in another known and suitable material and the creation of rolls without said central core.

[0003] As is known, these apparatuses are used for the winding in rolls of film in plastic material optionally machined beforehand for the formation of pre-cut and/or prepunched bags or, likewise, for the winding of film of paper for hygienic-sanitary use and the like.

[0004] Here below, however, specific reference will be made to the process of winding of film in plastic material.

[0005] Referring preferably to plastic bags, they can be wound on a core in cardboard or in another suitable material such as, for example, in the case of bags for use as packaging (for example the bags typically used in the fruit and vegetable sections of supermarkets) or can be wound into rolls without core such as, for example, in the case of bags used for refuse collection.

[0006] In the process of winding of the plastic film to define a roll, one of the more critical problems is represented by the mode of hooking of the film on the cardboard core around which to wind it.

[0007] According to some traditional technical solutions the film is guided in coupling to the core by means of mobile rollers which force the film to couple with the new core aided by a jet of air which pushes the film exiting from the core into the zone of contact between the film entering and the core itself. The film is thus "pinched" and the tension of the film which is created between the two mandrels causes the tearing of the zone wherein the pre-cut knurling is formed.

[0008] However this solution is mainly suitable in the case of film of reduced thickness for which the jet of air is sufficient for pushing the same film into the zone in which it will be pinched by the core.

[0009] Moreover this traditional solution is only suitable in the case of rolls provided with a central core which is rigidly stabilised on the mandrel by means of a movement of expansion with pneumatic actuation of the same mandrel.

[0010] To avoid the disadvantages given above a suitable device has been developed to allow the winding of rolls with and without central core.

[0011] This solution consists of the use of a system of hooking of the film to be wound comprising a pair of grippers sliding inside a guide bushing with said grippers apt to take said film, to restrain it and to wind it taking account of the fact that the same grippers are moved to rotate. Moreover the same grippers tighten the film with respect to the grippers which restrained it previously (another winding station) so as to cause the tearing at the pre-cut

knurling.

[0012] The blocking of the film for the subsequent driving in rolling on the core when the film grippers are made to rotate is performed by means of a tongue which engages with a portion of said film, driving it around the core during the rotation of the grippers which restrain said same core. This movement of rotation/driving of the film by means of the tongue causes, likewise, the tearing of the film with respect to the previous roll at the pre-cut knurling.

[0013] However this solution has a considerable and important disadvantage linked to the fact that, in the case of winding of the film on cores, it is possible to wind at most two rolls of which one mounted on a pair of grippers and one on an opposite pair of grippers. EP 2230067 in the name of the same Applicant describes a machine for the production of rolls of pre-cut bags and with punched handles comprising a station of winding wherein at least one axis of winding is provided, carried by two side carousels, supported by intermediate supports and made up of a pair of opposite grippers connected mechanically one to the other to rotate in the same direction and at the same speed.

[0014] The object of the present invention is that of obviating the disadvantages stated above.

[0015] More particularly the object of the present invention is that of providing an improved device for the winding of rolls suitable to allow a simultaneous winding of a plurality of rolls.

[0016] A further object of the present invention is that of providing a flexible and improved winding device apt to allow the winding both of rolls provided with a core and of rolls without a core.

[0017] A further object of the present invention is to make available to users an improved device for the winding of rolls with and without core apt to guarantee a high level of resistance and reliability in time and such, moreover, as to be easily and economically produced.

[0018] These and other objects are achieved by the system of the invention that has the features of claim 1.

[0019] According to the invention an improved device is provided for the winding of rolls with and without core, especially suitable for the winding of a film for plastic bags, applied to a rotation turret or head of an apparatus or machine for winding and comprising pairs of opposite grippers longitudinally developed, co-axially and symmetrically arranged with respect to a vertical plane and each with one of the two ends apt to allow the hooking with respect to a support structure suitable for moving said grippers in axial sliding with respect to a guide bushing and to at least one support flange attached with respect to the apparatus or machine for winding and coaxial one to the other, with the guide bushing arranged between said support structure and said support flange, the pairs of grippers comprising each one an upper gripper and a lower gripper one opposite to the other, with said pairs of grippers provided with a fixed tongue suitable for coupling, in the case of a roll provided with core, with the

exterior of a core and for hooking the film for driving of the same, said device which likewise comprises mobile means with magnetic drive apt to couple with at least one further core fitted on the same pair of grippers for the hooking and the driving of a further film to be wound into a roll.

[0020] Advantageous embodiments of the invention are disclosed by the dependent claims.

[0021] The constructional and functional features of the improved device for winding rolls with and without core of the present invention will be made clearer by the following detailed description, in which reference is made to the accompanying drawings which represent a preferred and non-limiting embodiment thereof, in which:

Figure 1 represents schematically a side view in longitudinal section of the improved device for winding rolls with and without core of the present invention according to a first working configuration;

Figure 2 shows schematically the device of the invention shown in a greater longitudinal extension in accordance with a second working configuration;

Figure 3 shows schematically an enlarged detail of a portion of the device as per the preceding drawings;

Figure 4 shows schematically a section view along an axial plane A-A of the enlarged detail of Figure 3;

Figure 5 shows schematically a side view of the winding apparatus provided with the improved device of the invention.

[0022] Referring to the aforementioned drawings, the improved device for the winding of rolls with and without core of the present invention, denoted overall by 10 in the drawings, comprises a pair of grippers 11 defined by an upper gripper 12 and a lower gripper 14 and a further pair of grippers 13 defined by a further upper gripper 16 and by a further lower gripper 18 (the second pair is partially shown in Figure 2), with said pairs of grippers opposite one to the other, longitudinally developed, coaxial one to the other, with one end 20 suitable for allowing the hooking of the pair of grippers to a drive unit (not shown, in the drawings only the support structure of the pair of grippers 11 is shown) and with the opposite end free.

[0023] The drawings considered for the description of the device of the invention illustrate schematically the constructional features of the pair of grippers 11 and of the constructional-functional elements associated with it, taking account of the fact that the pair of grippers 13 is wholly identical to said first pair of grippers and symmetrically arranged with respect thereto (referring to a vertical plane indicated by X in Figure 2).

[0024] More particularly, referring to Figure 2, the pairs of opposite grippers 11 and 13 are arranged symmetrically one to the other, as defined above, with respect to the vertical plane X.

[0025] A shim 5 attached to a coupling flange 6 (not described as per sé known) keeps the gripper 12 dis-

tanced from the gripper 14 and the gripper 16 from the gripper 18. Moreover, said upper and lower grippers of the pairs of grippers 11 and 13 have sections with growing thickness along the longitudinal development starting from the free end in the direction of the opposite end attached with respect to the support structure 20, as schematised in Figures 1 to 3.

[0026] The pair of grippers 11 slides internally and coaxially to a guide bushing 22 fixed with respect to the frame of the apparatus or winding system (not shown in the drawing).

[0027] The lower gripper 14 of the pair of grippers 11, at the end restrained with respect to the end 20, is provided with a tongue 24, arranged parallel to said lower gripper, developed away from said end 20 and in the direction of the free end of the gripper and with an end portion, turned in the direction of the end 20, rigidly restrained externally to the lower gripper 14 by means of screws or pins or equivalent retaining means. The end opposite to that of the restraint with respect to the lower gripper is, instead, free to perform the function described in detail here below.

[0028] The same lower gripper 14, about midway along its length development, comprises a further tongue 26 developed in the direction of the free end of the lower gripper.

[0029] The further tongue 26 is mobile and pivoted with respect to the lower gripper 14 by means of a hinged restraint 28 at one of its ends turned in the direction of the tongue 24 and, in the rest condition, is housed in a groove 30 of the lower gripper, not projecting with respect thereto and restrained thereto by means of one or more magnets 32 integrated in the same lower gripper 14 at the groove 30, as schematised in the enlarged detail of Figure 3. Said magnets 32 act in attraction on the free end of the further tongue 26 which, rotating with respect to the hinge 28, is arranged internally to the groove 30 of the lower gripper 14.

[0030] The device of the invention comprises, further, an innovative support flange 34 fixed with respect to the frame of the winding machine or apparatus 7 and, more particularly, attached with respect to a rotation turret or head 33 for the performing of the cycle of winding of the strip as described here below.

[0031] The support flange 34 comprises a rotating flange 36 arranged internally and coaxially to said support flange (as shown in Figure 3) and rotating with respect to the support flange 36 fixed and provided centrally with a through opening 38 and with a spacer 40 arranged internally and coaxially to said opening. Said through opening and spacer have the function of allowing and guiding the movement of the pair of grippers 11 as described in detail here below.

[0032] The rotating flange 36, moreover, houses a further magnet 42 with features of magnetic attraction superior to those of the one or more magnets 32 of the lower gripper 14 of the first pair of grippers 11. The further magnet 42 is in a position substantially opposite that of

the one or more magnets 32 of the lower gripper.

The rotating flange 36 is made preferably in non-magnetic material in order not to alter or reduce the magnetic power of the further magnet 42.

[0033] The functioning of the improved device for winding rolls, described in detail above with reference to the constructional features, is explained here below with reference to the condition of winding of a roll provided with core and of a roll without core. Referring to the condition of winding of a roll provided with core, Figure 5 illustrates the initial phase wherein the cores 46 coming from a magazine or store of cores 48 are conveyed at a loading station wherein they are fitted on the pair of grippers 11 (the procedure is wholly similar for the opposite pair of grippers 13).

[0034] More particularly the grippers of the pair of grippers 11 have a suitable length for supporting two cores 46.

[0035] The upper gripper 12 and the lower gripper 14 of the pair of grippers 11, moving slidingly forwards with respect to the guide bushing 22, engage coaxially and internally to the cores 46 with their own free end (Figure 1).

[0036] In this phase the further tongue 26 is restrained in the groove 30 of the lower gripper 14 through the effect of the action of magnetic attraction of the one or more magnets 32 so as to be able to traverse the core 46 during the phase of sliding of the pair of grippers 11 with respect to the guide bushing 22.

[0037] When, during the phase of sliding wherein the pair of grippers 11 moves with the end 20 in proximity of the abutment with respect to the guide bushing 22 (Figure 2), said further tongue 26, having traversed the whole core 46 closest to the guide bushing, arrives at the support flange 34 and the action of the further magnet 42 forces its movement (with respect to its hinged end) towards the exterior of the groove in such a way that said further tongue goes to engage with the outer surface of the core 46 placed downstream of the support flange 34 and, at the same time, the tongue 24 engages with the outer surface of the core 46 placed upstream of said support flange (considering as "upstream" the part turned in the direction of the end 20 of the pair of grippers 11).

[0038] During this phase of sliding of the pair of grippers 11 with respect to the guide bushing 22 and to the support flange 34, the inner surfaces of the opposite upper 12 and lower grippers 14, shaped with variable section as described above, engage with the spacer 40 of the support flange 32. At the same time the free end of the grippers engages with the spacer 5. The spacer 5 and the spacer 40 impose a movement of reciprocal distancing of said grippers so as to tighten the cores 46 preventing any relative movements thereof.

[0039] A film 50 to be wound around the cores 46, guided by means of rollers 51 and positioned by means of a film movement device 53, during the movement described above, finds itself in intermediate position between the tongue 24 and the core 46 upstream and be-

tween the further tongue 26 and the core 46 downstream. In this way the film 47 finds itself lapping the outer surface of the core 46.

[0040] On reaching this condition the pair of grippers 11 is made to rotate with respect to the longitudinal axis thereof, imposing the rotation of the cores 46 and the winding of the film 50 around the cores through the effect of the driving of the tongue 24 and of the further tongue 26.

[0041] At the end of the phase of winding of the film 50 around the core 46, the pair of grippers 11 is withdrawn from the cores 46 by means of an action of sliding with respect to the support flange 34 and to the guide bushing 22 in a direction opposite to that described above with reference to the phase of insertion/coupling and, consequently, the further tongue 26 disengages with respect to the core 46 placed downstream of the support flange and, moving away from said same flange, returns into a position of rest inside the groove 30 of the lower gripper 14 through the effect of the attraction exerted by the magnets 32.

[0042] In the case of winding of a roll without core, during the phase of sliding/insertion of the pair of grippers 11, the film 50 is in intermediate position between the upper gripper and the lower gripper and, therefore, is wound on itself during the phase of rotation by the pair of grippers 11.

[0043] Both in the case of winding of the film around a core and in the case of no core, the rotation of the pair of grippers causes a tensioning of the film 50 with respect to the pair of grippers which was winding previously (taking account of the fact that the apparatus or machine for winding comprises a turret rotating during the cycle of machining) causing the tearing thereof in the zone of knurling and pre-cutting.

[0044] As can be seen from the above the advantages that the device of the invention achieves are clear.

[0045] The improved device for the winding of rolls of the present invention has the advantage of allowing a simultaneous winding of a plurality of rolls with core, with the possibility of a use of the same device also for processes of winding of rolls without core.

[0046] A further advantage is represented by the fact that the tongues which can be moved by magnetic means allow a simple and convenient hooking of the film for the winding.

[0047] A further advantage is represented by the fact that the possibility of performing the simultaneous winding of two rolls for each pair of grippers allows the obtaining of a reduction of the times of production with a consequent lowering of costs.

[0048] According to a possible alternative embodiment, although constructionally more complex, more than one tongue 26 can be provided along the longitudinal development of at least one of the pairs of grippers 11 or 13, so as to allow a simultaneous winding of a higher number of rolls of plastic film.

In this case additional support flanges 34 will be provided,

with magnets 42 and magnets 32 having growing forces of attraction away from the bushing 22 to act on the further tongues 26 in a differentiated way so as to allow the outermost ones (i.e. closest to the free ends of the opposite upper and lower grippers) to traverse the flanges closer to the bushing without opening, exiting from the containment groove 30. The features of the magnets 32 must likewise be chosen in a manner concordant with those of the magnets 42 in such a way that the force of attraction of said magnets 32 of the outermost tongues is not overridden by that of the further magnets 42 of the support flanges closer to the bushing during the phase of sliding of the pairs of grippers.

[0049] Although the invention has been described above with particular reference to one of its embodiments given solely by way of a non-limiting example, numerous changes and variations will appear clear to a person skilled in the art in light of the description given above. The present invention intends, therefore, to embrace all the modifications and the variations that fall within the scope of the following claims.

Claims

1. An apparatus or machine for winding (7) with a rotation turret or head (33) provided with at least one device (10) for the winding of rolls with and without core, especially suitable for the winding of a film (50) for plastic bags, said device (10) comprising pairs of opposite grippers (11, 13) longitudinally developed, co-axially and symmetrically arranged with respect to a vertical plane and each with one of the two ends (20) apt to allow the hooking to a structure for moving said grippers in axial sliding with respect to a guide bushing (22) and to at least one support flange (34) fixed with respect to the apparatus or machine for winding (7) and coaxial one to the other, with the guide bushing (22) arranged between said end (20) of the grippers and said support flange (34), the pairs of grippers each comprising an upper gripper (12, 16) and a lower gripper (14, 18) opposite one to the other, with said pairs of grippers provided with fixed tongues (24) suitable for coupling with the exterior of a core (46) and for hooking the film (50) for driving the same, said device **characterised in that** it comprises mobile means with magnetic drive apt to couple with at least one further core (46) fitted on the same pair of grippers for the hooking and the driving of a further film (50) to be wound into a roll.
2. Winding apparatus according to claim 1, **characterised in that** said mobile means with magnetic movement comprise a further tongue (26) pivoted at one of its ends in a groove (30) of one of the opposite grippers (12, 14, 16, 18) of the pair of grippers (11, 13) and with the other end free and magnetic means apt to move said further tongue (26) in entry/exit with respect to said groove (30).
3. Winding apparatus according to claim 1 or 2, **characterised in that** said magnetic means comprise one or more magnets (32) integrated in one of said opposite grippers of the pair of grippers (11, 13) apt to retain the further tongue (26) in the groove (30) and a further magnet (42) attached to a rotating flange (36) of the support flange (34) and suitable for attracting said tongue outside said groove.
4. Winding apparatus according to claim 3, **characterised in that** the further magnet (42) has a magnetic attraction greater than that of the one or more magnets (32).
5. Winding apparatus according to claim 3 or 4, **characterised in that** the rotating flange (36) of the support flange (34) is made in a non-magnetic material and is provided with a central through opening (38) and with a spacer (40) arranged internally and coaxially to said opening, with said spacer apt to engage in an intermediate position between the upper gripper and the lower gripper of the pair of grippers (11, 13) to perform a movement of reciprocal moving away of said upper and lower grippers so as to tighten the cores (46) at their inner surface.
6. Winding apparatus according to claim 3 or 5, **characterised in that** the further magnet (42) is attached to the rotating flange so that the further tongue (26) is in an intermediate position between the one or more magnets (32) and the further magnet (42) when it traverses the through opening (38) of the rotating flange (36) of the support flange (34).
7. Winding apparatus according to any one of claims 2 to 6, **characterised in that** the further tongue (26) is restrained to a gripper (12, 14, 16, 18) of the pair of grippers (11, 13) substantially midway along the development in length of said gripper and is developed in the direction of the free end of the same gripper.
8. Winding apparatus according to any one of the preceding claims, **characterised in that** the fixed tongue (24), the further tongue (26) and the one or more magnets (32) are attached to the lower gripper (14, 18) of the pair of grippers (11, 13).
9. Winding apparatus according to any one of the preceding claims, **characterised in that** the fixed tongue (24), the further tongue (26) and the one or more magnets (32) are attached to the upper gripper (12, 16) of the pair of grippers (11, 13).
10. Winding device (10) for the winding of rolls with and without core, especially suitable for the winding of a

film (50) for plastic bags, applied to a rotation turret or head (33) of an apparatus or machine for winding (7), having the features of any one of the preceding claims.

5

10

15

20

25

30

35

40

45

50

55

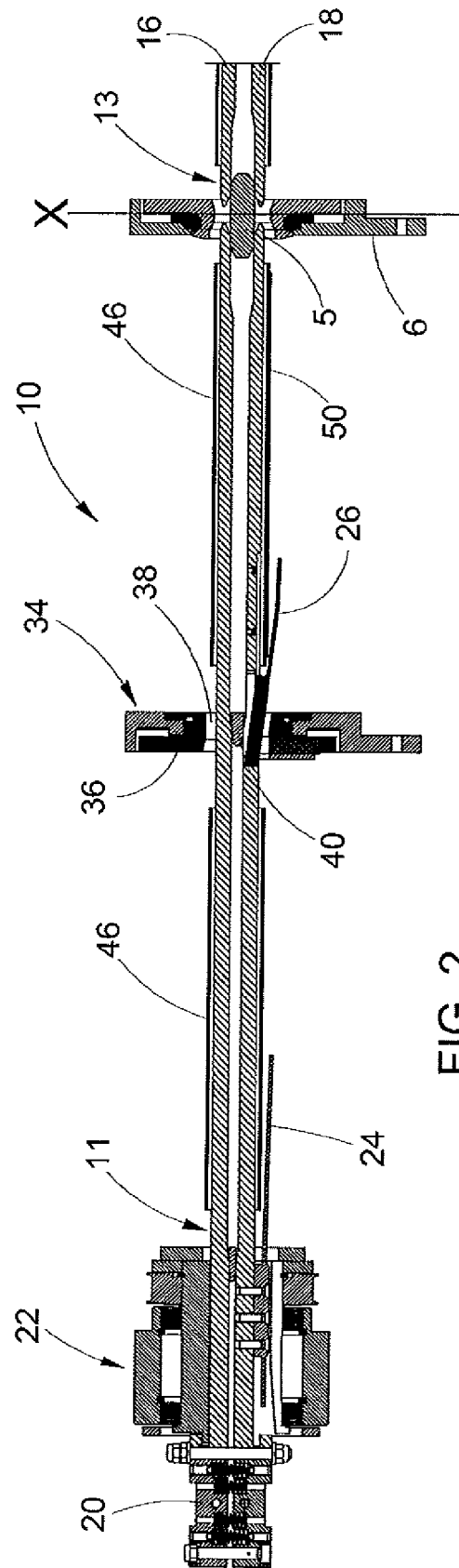
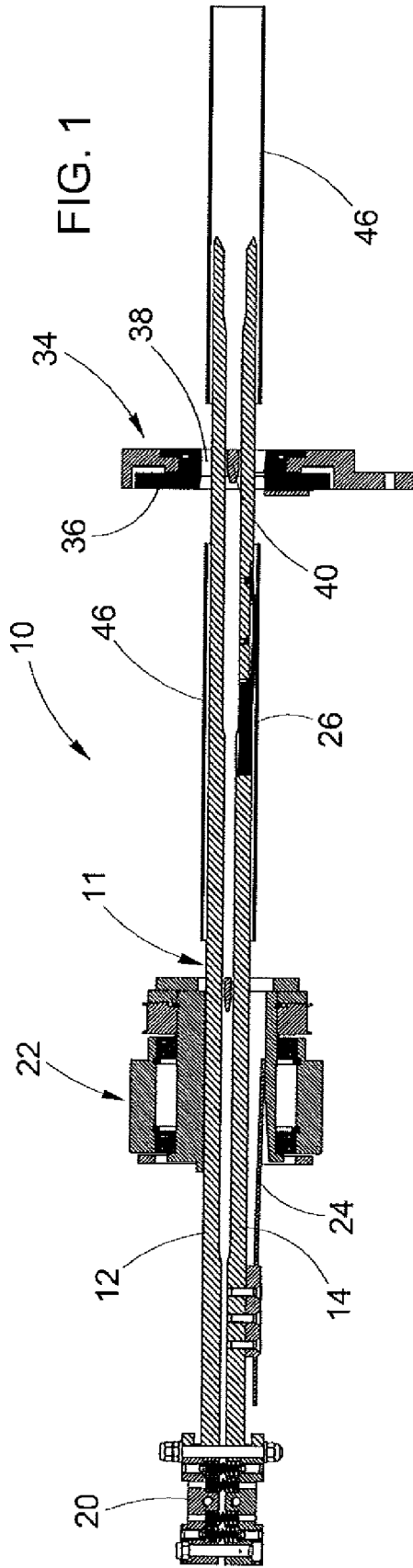

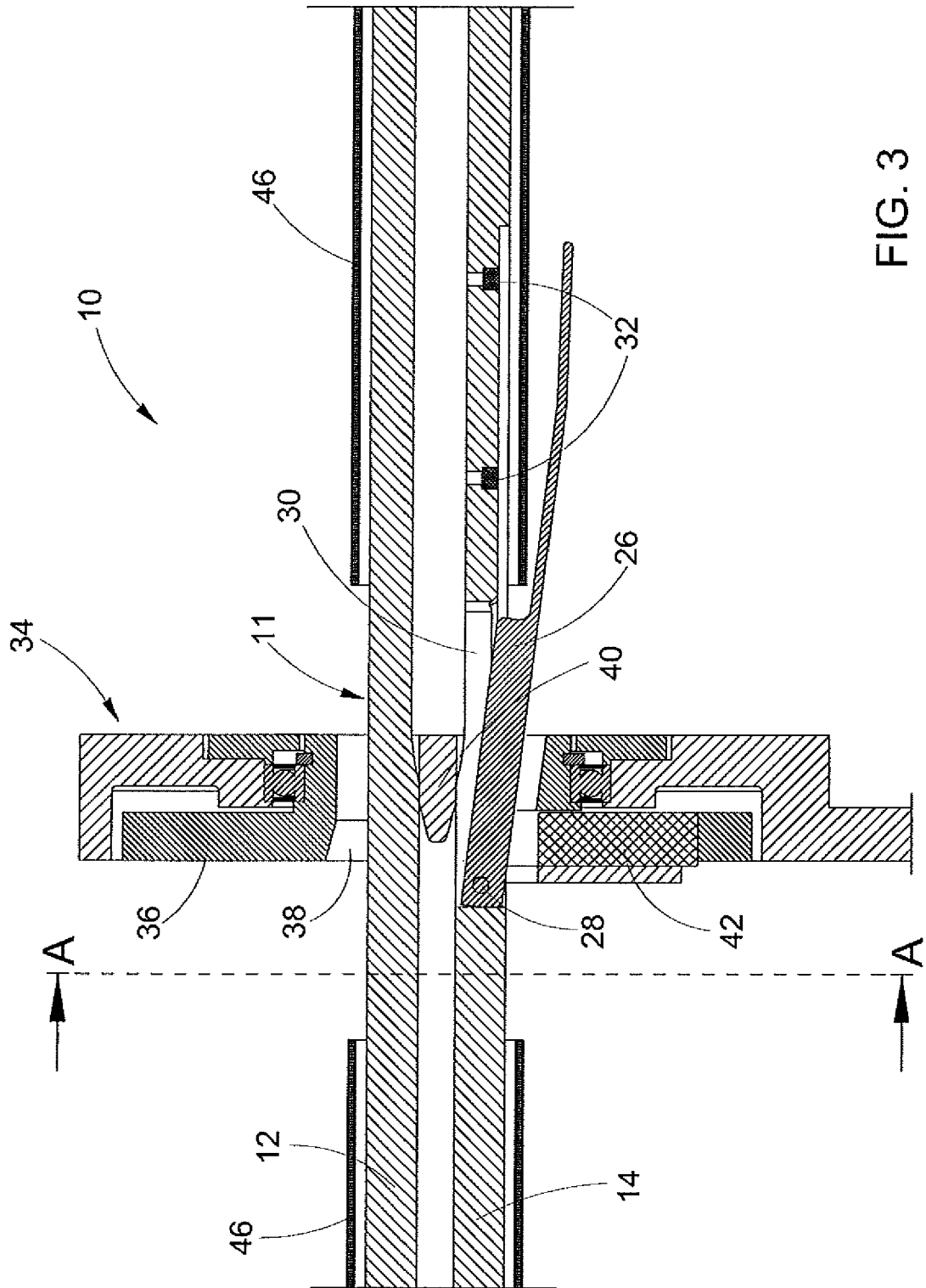

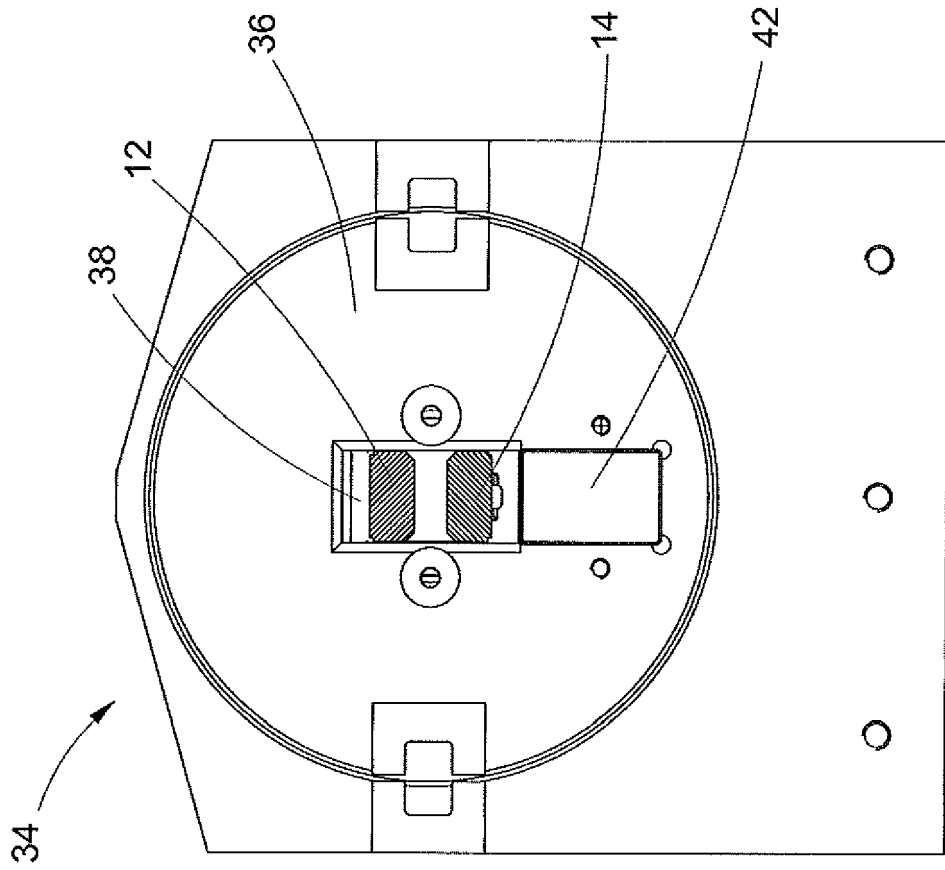

FIG. 4

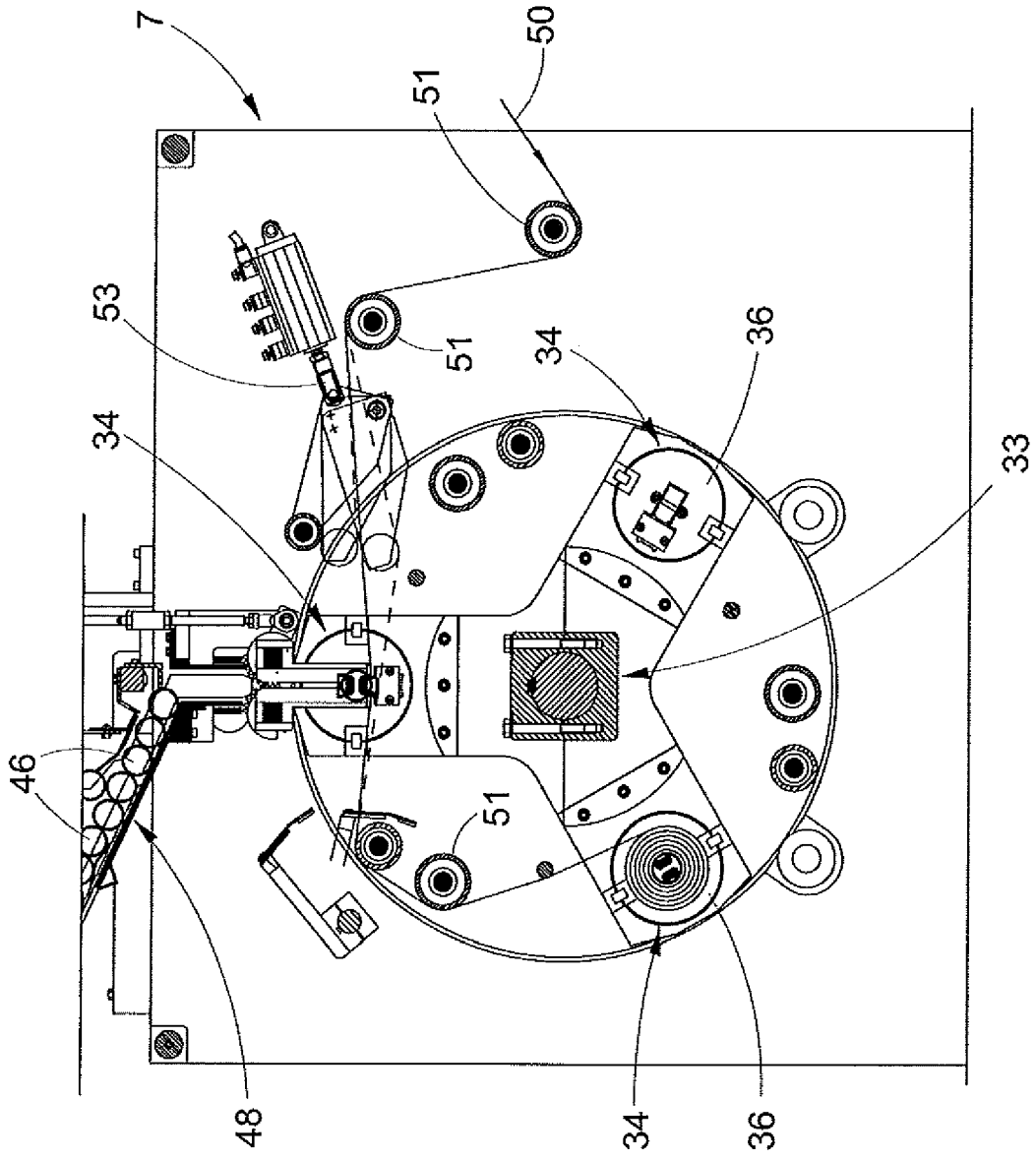

FIG. 5

REFERENCES CITED IN THE DESCRIPTION

This list of references cited by the applicant is for the reader's convenience only. It does not form part of the European patent document. Even though great care has been taken in compiling the references, errors or omissions cannot be excluded and the EPO disclaims all liability in this regard.

Patent documents cited in the description

- EP 2230067 A [0013]