



(12) **EUROPEAN PATENT APPLICATION**

(43) Date of publication:
06.04.2016 Bulletin 2016/14

(51) Int Cl.:
G04C 17/00 (2006.01) G04G 21/02 (2010.01)
G04G 21/04 (2013.01)

(21) Application number: **14187207.7**

(22) Date of filing: **30.09.2014**

(84) Designated Contracting States:
AL AT BE BG CH CY CZ DE DK EE ES FI FR GB GR HR HU IE IS IT LI LT LU LV MC MK MT NL NO PL PT RO RS SE SI SK SM TR
 Designated Extension States:
BA ME

(72) Inventor: **Stas, Peter**
1228 Plan-les-Ouates (CH)

(74) Representative: **Richard, François-Régis**
e-Patent S.A.
Rue Saint-Honoré, 1
2001 Neuchâtel (CH)

(71) Applicant: **Frédérique Constant S.A.**
1228 Plan-les-Ouates (CH)

(54) **Watch having distinct display modes and a mode indicator**

(57) A wristwatch comprising an analog display of time and date; a micro-controller, whereby the micro-controller stores a set of indicator modes, whereby the set of indicator modes comprises at least a date mode and a first mode, and for each indicator mode at least a corresponding value; a date and information display part; and a selecting means being arranged to receive an actuation. the date and information display part comprises a display with date and indicator icons, enabled for an analog display of any one of the numbers between 1 and 31 and at least the indicator icon representative of the at least first mode; and a display with percentage values. The selecting means, when actuated, triggers the micro-controller to switch to a determined indicator mode

taken from the set of indicator modes stored in the micro-controller, and is further configured to cause the display with date and indicator icons to display in analog mode the date or the indicator icon representative of the determined indicator mode, whereby if the determined indicator mode is the date mode then the display with date and indicator icons displays the corresponding value of the date, and if the determined indicator mode is the first mode, then display with date and indicator icons displays a corresponding icon of the first mode, and a second hand is pointed to a percentage value on the display with percentage values corresponding to the corresponding value stored for the first mode.

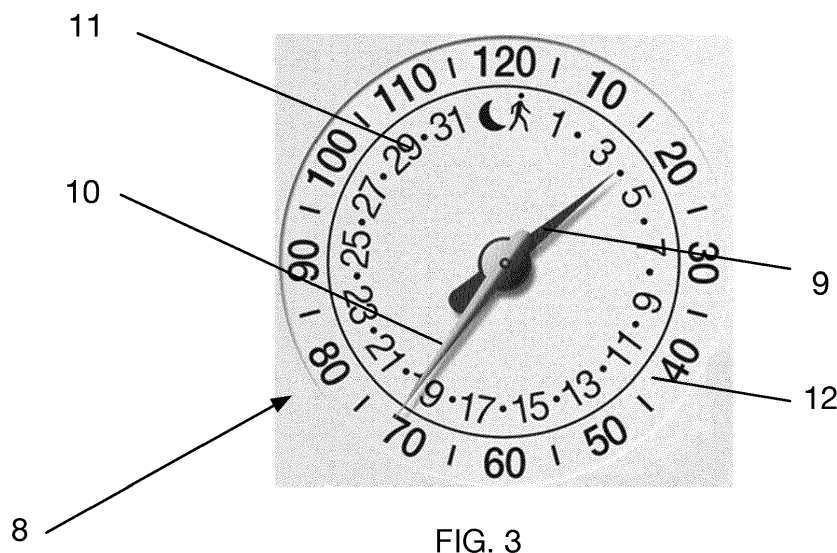

Description

Technical field

[0001] The present invention is related to the field of displaying information on wristwatches.

Background art

[0002] With the advent of Bluetooth connection to wristwatches, a multitude of information will need to be displayed on a wristwatch. As the surface area on a wristwatch is comparatively small, the method to display information is crucial.

[0003] It is an aim of the invention to maintain the luxury design of a wristwatch, considered a personal jewel for the wearer while at the same time displaying the multitude of information.

Disclosure of the invention

[0004] In a first aspect, the invention provides a wristwatch comprising an analog display of time and date; a micro-controller, whereby the micro-controller stores a set of indicator modes, whereby the set of indicator modes comprises at least a date mode and a first mode, and for each indicator mode at least a corresponding value; a date and information display part; and a selecting means being arranged to receive an actuation. the date and information display part comprises a display with date and indicator icons, enabled for an analog display of any one of the numbers between 1 and 31 and at least the indicator icon representative of the at least first mode; and a display with percentage values. The selecting means, when actuated, triggers the micro-controller to switch to a determined indicator mode taken from the set of indicator modes stored in the micro-controller, and is further configured to cause the display with date and indicator icons to display in analog mode the date or the indicator icon representative of the determined indicator mode, whereby if the determined indicator mode is the date mode then the display with date and indicator icons displays the corresponding value of the date, and if the determined indicator mode is the first mode, then display with date and indicator icons displays a corresponding icon of the first mode, and a second hand is pointed to a percentage value on the display with percentage values corresponding to the corresponding value stored for the first mode.

[0005] In a preferred embodiment when the selecting means is actuated, the micro-controller is further configured to point a first hand to a part of the display with date and indicator icons representative of the determined indicator mode, whereby if the determined indicator mode is the date mode then the first hand is pointed to the corresponding value of the date, and if the determined indicator mode is the first mode, the first hand is pointed to a corresponding icon of the first mode on the display

with date and indicator icons.

[0006] In a further preferred embodiment the display with date and indicator icons and the display with percentage values are each circular displays disposed in a coaxial manner.

[0007] In a further preferred embodiment the wristwatch further comprises a radio receiving means for receiving information via a radio signal, whereby the radio receiving means comprises any one of the list comprising at least a bluetooth receiver, a cellular phone signal receiver, a wifi receiver.

[0008] In a further preferred embodiment, the set of indicator modes comprises a Sleep mode and an Activity mode, and a sleep value corresponding to the sleep mode is indicative of an amount of sleep recorded in a determined period of time, and an activity value corresponding to the activity mode is indicative of an amount of activity recorded in the determined period of time.

[0009] In a further preferred embodiment the selecting means is either one of a crown or a pusher of the wristwatch.

[0010] In a further preferred embodiment the display with date and indicator icons has a single graduation scale, a first part of which is dedicated to the date indication and a second part of which is dedicated to the indicator icons.

[0011] In a further preferred embodiment the display with date and indicator icons is a circular display and the indicator icons are printed on a sectorial part of the circular display, and the date is printed on the remaining part of the circular display.

[0012] In a second aspect, the invention provides a method for displaying information on an analog wristwatch. The method comprises: storing a set of indicator modes in a micro-controller, whereby the set of indicator modes comprises at least a date mode and a first mode, and for each mode at least a corresponding value; receiving at a selecting means an actuation; switching to a determined indicator mode taken from the set of indicator modes stored in the micro-controller upon receiving the actuation; causing an analog display with date and indicator icons, to display a date or an indicator icon representative of the determined indicator mode; whereby if the determined indicator mode is the date mode then the display with date and indicator icons displays the corresponding value of the date, and if the determined indicator mode is the first mode, the display with date and indicator icons displays a corresponding icon of the first mode, and a second hand is pointed to a percentage value on the display with percentage values corresponding to the corresponding value stored for the first mode.

[0013] In a further preferred embodiment the step of causing the analog display with data and indicator icons to display a date or an indicator icon further comprises pointing a first hand to a part of the display with date and indicator icons, representative of the determined indicator mode; whereby if the determined indicator mode is the date mode then the first hand is pointed to the cor-

responding value of the date, and if the determined indicator mode is the first mode, the first hand is pointed to a corresponding icon of the first mode on the display with date and indicator icons, and a second hand is pointed to a percentage value on the display with percentage values corresponding to the corresponding value stored for the first mode.

[0014] In a further preferred embodiment the set of indicator modes comprises a Sleep mode and an Activity mode, and a sleep value corresponding to the sleep mode is indicative of an amount of sleep recorded in a determined period of time, and an activity value corresponding to the activity mode is indicative of an amount of activity recorded in the determined period of time.

[0015] In a further preferred embodiment if the determined indicator is the date mode, the second hand remains pointed to a previous percentage value on the display with percentage values that corresponds to the corresponding value stored for the indicator mode that was selected previous to selecting the date mode.

[0016] In a further preferred embodiment the step of receiving the actuation at the selecting means comprises registering a press of either one of a crown or a pusher of the wristwatch.

[0017] The invention combines the selection and display of modes on a wristwatch with typical horological display information like time and date.

Brief description of the drawings

[0018] The present invention is illustrated by way of example, and not by way of limitation, in the figures of the accompanying drawings and in which like reference numerals refer to similar elements and in which:

figure 1 illustrates an example embodiment of a wristwatch with an analog display according to the invention;

figure 2 is a schematic illustration of a system comprising a smartphone and a wristwatch according to the invention;

figure 3 is an illustration of a date and information display part according to the invention;

figure 4 illustrates a detail from the date and information display part in figure 3;

figure 5 illustrates a detail from the date and information display part in figure 3;

figure 6 is an illustration of a further date and information display part according to the invention;

figure 7 show a detail of a date and information display part according to a preferred embodiment of the invention;

figures 8-15 illustrate an example method of use of the invention;

figure 16 shows an example analog movement used in the connected portable device according to the invention;

figure 17 is a schematic illustration showing an ex-

ample data and signal exchange of the connected wristwatch according to the invention; and figures 18 and 19 illustrate an example embodiment of a detail of the date and information display part according to the invention.

Mode(s) for carrying out the invention

[0019] This invention realizes the display of multiple information on a wristwatch with hands or disc indicators. It enables the display of multiple sets of information in a same scale, and therewith allows to use less space than prior art displays while still remaining ergonomic and user friendly.

[0020] Traditional Swiss wristwatches look elegant and luxurious. Adding a digital display to such wristwatch is considered to reduce the luxury appeal of a watch as a jewel on the wrist. The present invention solves the problem to display multiple information on a connected wristwatch while maintaining a traditional wristwatch design.

[0021] Display of horological information like time, date, day, month by watch hands or disc indicators is a centuries old concept. This invention enables the display of a wide range of digital available information by hand or disc on a wristwatch.

[0022] The wristwatch receives information via a radio signal. To this end it comprises radio receiving means. Such a wristwatch may also be called a connected wristwatch.

[0023] In a first preferred embodiment, the wristwatch receives the information via a Bluetooth connection. The Bluetooth connection is established for example to a smartphone or any other Bluetooth capable device.

[0024] Figure 1 shows a connected wristwatch 1 with an analog display according to an example embodiment of the invention, which corresponds to an analog wristwatch. The analog character of the connected portable device 1 emanates from the manner in which it displays the time using the hands 2 as opposed to a digital display (not represented in figure 2).

[0025] Figure 2 show an example embodiment of a system comprising the connected wristwatch 1 with an analog display, and a smartphone 3 which is configured to transmit via double arrow 4, i.e., over wireless radio signals information to the connected wristwatch 1 where the radio signal is received by means of radio receiving mean 44 inside de wristwatch. The radio receiving means are not explicitly visible in figure 2 but rather are inside the casing of the wristwatch. The double arrow 4 connection may for example be realized using the widespread Bluetooth Low Energy standard, but any other standard that may be installed in the connected device may be implemented as an alternative without departing from the scope of the invention.

[0026] The smartphone 3 is also connected to the internet 5 as represented by double arrowed dotted line 6.

[0027] In a second preferred embodiment not illustrat-

ed, the wristwatch receives the information via a cellular phone signal, e.g., according to the 4G standard, or a WIFI signal. In the second preferred embodiment the information is received directly from the cloud.

[0028] The information is converted into at least a key number representing a key information percentage realized of a target for a selected period. Multiple key information percentages may be communicated to the wristwatch via the radio receiving means. The user may scroll through key information percentages associated to a respective corresponding indicator, i.e., successively select a determined key information percentage, by actuating a selecting means 7—as shown in figure 1—comprised in the wristwatch 1.

[0029] Preferably the selecting means 7 is embodied as the crown or the pusher of the wristwatch 1. In figure 1 the actuation of the selection means is represented by a thick line arrow pointing to the selecting means 7 in the directions that needs to be pressed to actuate.

[0030] Each actuation of the selecting means 7 activates one of the corresponding indicators.

[0031] Figure 1 further shows an example of a date and information display part 8 of the wristwatch 1.

[0032] Figure 3 illustrates an example of the date and information display part 8, that comprises a first hand 9 and a second hand 10 that respectively point to a display with dates and indicator icons 11 and a display with percentage values 12.

[0033] For the purpose of display of the information, i.e., display of the indicator activated and the corresponding key information percentage, the first hand 9 and the second hand 10 are used. The first hand 9 is oriented to a first position representative of the indicator activated, thereby showing which indicator is activated. In figure 3, the indicators are represented by a moon icon, a walking person icon and a series of numbers from 1 to 31 representing the dates of a month. The second hand 10 is oriented to a second position representative of the value of the corresponding key information percentage, thereby showing the corresponding key figure. In figure 3 the values shown on the display with percentage values 12 range between 10 and 120. A value between 1 and 10 would be represented between 120 and 10.

[0034] To enable the wristwatch to show horological information like time and date, the wristwatch comprises at least an icon, each icon being representative for one of the indicators available, i.e., each icon represents a specific information mode.

[0035] In a preferred embodiment, the problem of limited information and reducing the need for additional hands on the wristwatch, is solved by including the icons as part of the circular date display, as shown in the example of figure 3 and in the figure 4 where the display for dates and indicator icons 11 of figure 1 is shown separately. In this preferred embodiment the icons are printed on a sectorial part of the circular display, and the date is printed on the remaining part of the circular display.

[0036] In a preferred embodiment shown in figures 18

and 19, the display for dates and indicator icons is realized also in an analog manner, but instead of using a circular display and a hand, the date and the icon(s) are displayed by means of two disks. In the illustrated example one of the disks contains on its periphery the digits 1-9 as well as a moon and a walking man icons, while the other one of the disks contains the digits 1-9 and a blank spot. This preferred embodiment may advantageously be used in combination with an aperture through which the two disks may partially be viewed as illustrated by the rectangle in bold lines that covers a part of the respective disks. In figure 18 the position of the two disks results in the display of the date 19. In figure 19 the position of the two disks results in the display of the *Moon* icon. While the remaining description of the invention is made in reference to the circular display with hand embodiment, it is understood that the similar results and functions may be achieved using the embodiment illustrated in figures 18 and 19 without departing from the invention.

[0037] Figure 5 shows a view of the display with percentage values 12 as separated out from figure 3.

[0038] One example of the display according to the invention—corresponding to the one discussed herein—above with figures 3, 4 and 5—includes percentage of Sleep and Activity Recording on a Health Timer wristwatch. In this example the first hand 9 shows or points which recording is active, thereby pointing to the *moon* icon for sleep recording and to the *walking person* icon for activity recording. The user may further actuate the selecting means 7 (not illustrated in figure 3 and 4), e.g., by pressing the crown again if appropriate, to see the date display.

[0039] Figure 6 illustrates a further example embodiment of the date and information display part 8, that comprises the first hand 9 and the second hand 10 that respectively point to a display with dates and indicators as capital letters A-B-C, and a display with percentage values 10-120. The indicators A, B and C each stand for a type of business information, such as for example a key performance indicator. The display with percentage values 10-120 is then to be used to display the value corresponding to the key performance indicator selected.

[0040] Figure 7 illustrates a further example of a display for use in the date and information part 8 in replacement of the display with percentage values. Instead of comprising percentage values 10-120, the display comprises numbers ranging from -10 to +10, the 0-value being represented by a mark in bold line located in the middle between the two numbers 2. The signs "-" and "+" on respective left and right sides of the display apply to all the numbers located on their respective sides.

[0041] The user is able to determine the key information percentages that may be communicated to the wristwatch via an application running on the smartphone or any other suitable device depending on the embodiment chosen. A user interface of the application enables the user to select a number of key information percentages,

e.g., selecting up to five key information types, setting a range, and setting the period. The wristwatch 1 is configured to periodically receive the selected key information percentages corresponding to the indicators via the Bluetooth or any other connection.

[0042] The first hand 9 and the second hand 10 are periodically pointed to values corresponding to updated information by means of the firmware program running on a micro-controller on the connected wristwatch 1.

[0043] Figure 16 contains an example embodiment for a quartz analog movement that can be used to actuate at least the hands 2 of the connected wristwatch 1 both shown in figure 1. Such quartz analog movement or any other movement to be used is mounted on a circuit board that also is connected to a radio receiving means (not represented), for example one according to the bluetooth low energy standard.

[0044] Figure 17 contains a logical representation of the connected wristwatch 1 with the analog display, which comprises an analog display 13 for the hands 2 (not represented), the date and information display 8, the radio receiving means 44, and the micro-controller 14. All these features and the relations between them will now be discussed.

[0045] The radio receiving means 44 are enabled to receive information over a radio signal from a source 15 located outside of the connected wristwatch 1, as represented by a dotted line connecting the source 15 and the radio receiving means 44.

[0046] The micro-controller 14 is enabled to read the received information as indicated by the bi-directional arrow 16. Upon reading the received information, a first signal 17 is output to the date and information display 8, this causing the second hand 10 (not represented) to be pointed (not represented) to a determined value on the scale of the display corresponding to the received information and the selected active indicator (not represented).

[0047] The controller means 14 is further enabled to output a second signal 18 to the analog display 13, this causing the hands 2 (not represented) to indicate the time.

[0048] The micro-controller is understood to be housed in the wristwatch 1 together with a source of energy, e.g., a battery, and at least an analog movement to actuate the hands 2 and/or the first hand and the second hand (10) as appropriate.

[0049] The connected wristwatch (1) further may contain means for measuring sleep and activity of the user wearing the connected wristwatch, and means for storing the measured values.

[0050] In the following a number of examples are described relating to use examples of the connected wristwatch 1.

[0051] Figure 8 shows the date and information display part 8 with the first hand 9 and the second hand 10 in the left part. In the upper right part of figure 8, the display with percentage values 12 is represented separately with

the second hand 10 pointing to a value on the 0-120 scale, i.e., to the value 94. In the lower right part of figure 8, the display with dates and indicator icons 11 is represented separately with first hand 9 pointing to the date "21".

[0052] Figure 9 shows on its left part the same date and information display part 8 with the first hand 9 and the second hand 10 as in figure 8. After actuating the selecting means 7 (not shown in figure 9), the second hand 10 is pointed to the value 0 of the display with percentage values 12 as shown in the upper right part of figure 9. At the same time the first hand is pointed to the *moon* icon as shown in the lower right part of figure 9. In other words the sleep mode is activated by the actuating of the selecting means, and the value of sleep is set to 0 on the scale 0-120.

[0053] Figure 10 shows the situation of the date and information display part 8 after parts of the night have passed and sleep is active as set in figure 9. On the left part of the figure 10 the second hand points at a value slightly above 20 signaling that 20% have passed during the night. In the upper right part of figure 10 the second hand points to 95% after even more time of the night as passed. In the lower right part of figure 10 the first hand remains unchanged pointing at the *moon* icon showing that sleep is active.

[0054] Figure 11 departs from the situation where 95% have passed during active sleep mode as shown in the left part of the figure. After actuating the selecting means 7, the first hand 9 points to the *walking man* icon to indicate Activity mode is activated as shown in the lower right part of figure 11. The second hand is pointed to the value 0 to show the Activity result value for the days, which starts at 0%.

[0055] Figure 12 shows the situation of the date and information display part 8 after parts of the day have passed and Active mode is active as set in figure 11. Activity mode was active and still is. In the upper right part of figure 12 the second hand has moved to point to the value 20 which is representative of the number of steps taken during the day. In the lower right part of figure 12 the first hand still point to the *walking man* icon indicating that Activity mode is active.

[0056] Figure 13 departs from the situation where 20% have passed during active Activity mode as shown in the left part of the figure. After actuating the selecting means 7, the first hand 9 points to the date "23" as shown in the lower right part of figure 13. The second hand remains pointed to the value 20, thereby showing the Activity result value for the days. The steps that are illustrated in this figure happen when the user wishes to see the date.

[0057] Figure 14 departs from the situation where 20% have passed during active Activity mode as the situation was in previous figure 13 and the date is indicated as 23. After actuating the selecting means 7, the user reactivates Sleep mode. The first hand 9 points to the *moon* icon as shown in the lower right part of figure 14. The second hand is pointed to the value 95 from the previous

sleep mode and starts to continue progressing for a possible second sleep in the 24h cycle, as shown in the upper right part of figure 14. The steps that are illustrated in this figure happen when the user wishes to take a 2nd sleep during the day.

[0058] Figure 15 departs from the situation in figure 14 wherein 95% have passed during Sleep mode. After actuating the selecting means 7, the user reactivates Activity mode. This causes the second hand 10 to point to the value 20 again, ready to resume from the current value of Activity mode from the day as shown in the upper right part of figure 15. The first hand 9 is pointed to the *walking man* icon indicating that Activity mode is shown again as illustrated in the lower right part of figure 15.

[0059] The figures 8-15 have illustrated, for an example embodiment, the steps occurring at every actuating of the selecting means 7: the user cycles through Sleep mode - Activity mode - Date.

Claims

1. A wristwatch comprising
 - an analog display (2; 13) of time and date;
 - a micro-controller (14), whereby the micro-controller stores a set of indicator modes, whereby the set of indicator modes comprises at least a date mode and a first mode, and for each indicator mode at least a corresponding value;
 - a date and information display part (8);
 - a selecting means (7) being arranged to receive an actuation;
 - whereby the date and information display (8) part comprises

- a display with date and indicator icons (11), enabled for an analog display of any one of the numbers between 1 and 31 and at least the indicator icon representative of the at least first mode;

- a display with percentage values (12);

whereby the selecting means (7), when actuated, triggers the micro-controller (14) to switch to a determined indicator mode taken from the set of indicator modes stored in the micro-controller (14), and is further configured to cause the display with date and indicator icons (11) to display in analog mode the date or the indicator icon representative of the determined indicator mode, whereby

- if the determined indicator mode is the date mode then the display with date and indicator icons (11) displays the corresponding value of the date, and

- if the determined indicator mode is the first mode, then display with date and indicator icons (11) displays a corresponding icon of the first

mode, and a second hand (10) is pointed to a percentage value on the display with percentage values (12) corresponding to the corresponding value stored for the first mode.

2. The wristwatch of claim 1, wherein when the selecting means (7) is actuated, the micro-controller (14) is further configured to point a first hand (9) to a part of the display with date and indicator icons (11) representative of the determined indicator mode, whereby
 - if the determined indicator mode is the date mode then the first hand is pointed to the corresponding value of the date, and
 - if the determined indicator mode is the first mode, the first hand is pointed to a corresponding icon of the first mode on the display with date and indicator icons (11).
3. The wristwatch of claim 2, wherein the display with date and indicator icons (11) and the display with percentage values are each circular displays disposed in a coaxial manner.
4. The wristwatch (1) of any one of claims 1 and 2, further comprising a radio receiving means (44) for receiving information via a radio signal (4), whereby the radio receiving means comprises any one of the list comprising at least a bluetooth receiver, a cellular phone signal receiver, a wifi receiver.
5. The wristwatch (1) of any one of claims 1 and 2, wherein the set of indicator modes comprises a Sleep mode and an Activity mode, and a sleep value corresponding to the sleep mode is indicative of an amount of sleep recorded in a determined period of time, and an activity value corresponding to the activity mode is indicative of an amount of activity recorded in the determined period of time.
6. The wristwatch (1) of any one of claims 1 and 2, wherein the selecting means (7) is either one of a crown or a pusher of the wristwatch (1).
7. The wristwatch of claim 1, wherein the display with date and indicator icons (11) has a single graduation scale, a first part of which is dedicated to the date indication and a second part of which is dedicated to the indicator icons.
8. The wristwatch (1) of claim 2, wherein the display with date and indicator icons (11) is a circular display and the indicator icons are printed on a sectorial part of the circular display, and the date is printed on the remaining part of the circular display.
9. A method for displaying information on an analog wristwatch, comprising:

storing a set of indicator modes in a micro-controller (14), whereby the set of indicator modes comprises at least a date mode and a first mode, and for each mode at least a corresponding value;
 receiving at a selecting means (7) an actuation;
 switching to a determined indicator mode taken from the set of indicator modes stored in the micro-controller (14) upon receiving the actuation;
 causing an analog display with date and indicator icons, to display a date or an indicator icon representative of the determined indicator mode; whereby

if the determined indicator mode is the date mode then the display with date and indicator icons displays the corresponding value of the date, and
 if the determined indicator mode is the first mode, the display with date and indicator icons displays a corresponding icon of the first mode, and a second hand (10) is pointed to a percentage value on the display with percentage values (12) corresponding to the corresponding value stored for the first mode.

- 10.** The method of claim 9, wherein the step of causing the analog display with data and indicator icons to display a date or an indicator icon further comprises pointing a first hand (9) to a part of the display with date and indicator icons, representative of the determined indicator mode; whereby
 if the determined indicator mode is the date mode then the first hand is pointed to the corresponding value of the date, and
 if the determined indicator mode is the first mode, the first hand is pointed to a corresponding icon of the first mode on the display with date and indicator icons (11), and a second hand (10) is pointed to a percentage value on the display with percentage values (12) corresponding to the corresponding value stored for the first mode.
- 11.** The method of claim 9, wherein the set of indicator modes comprises a Sleep mode and an Activity mode, and a sleep value corresponding to the sleep mode is indicative of an amount of sleep recorded in a determined period of time, and an activity value corresponding to the activity mode is indicative of an amount of activity recorded in the determined period of time.
- 12.** The method of claim 11, wherein if the determined indicator is the date mode, the second hand (10) remains pointed to a previous percentage value on the display with percentage values (12) that corresponds to the corresponding value stored for the in-

dicator mode that was selected previous to selecting the date mode.

- 13.** The method of claim 9, wherein receiving the actuation at the selecting means comprises registering a press of either one of a crown or a pusher of the wristwatch (1).



FIG. 1

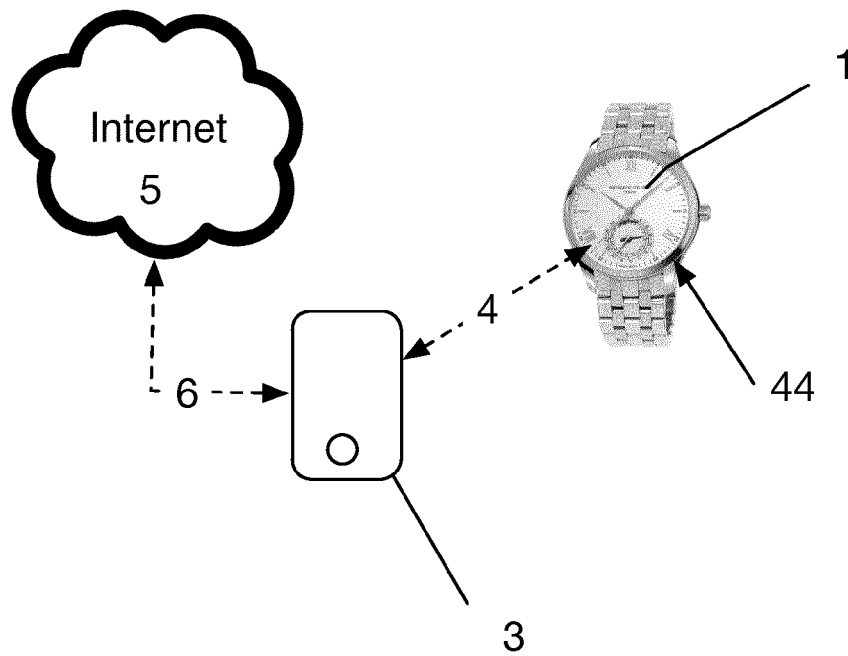
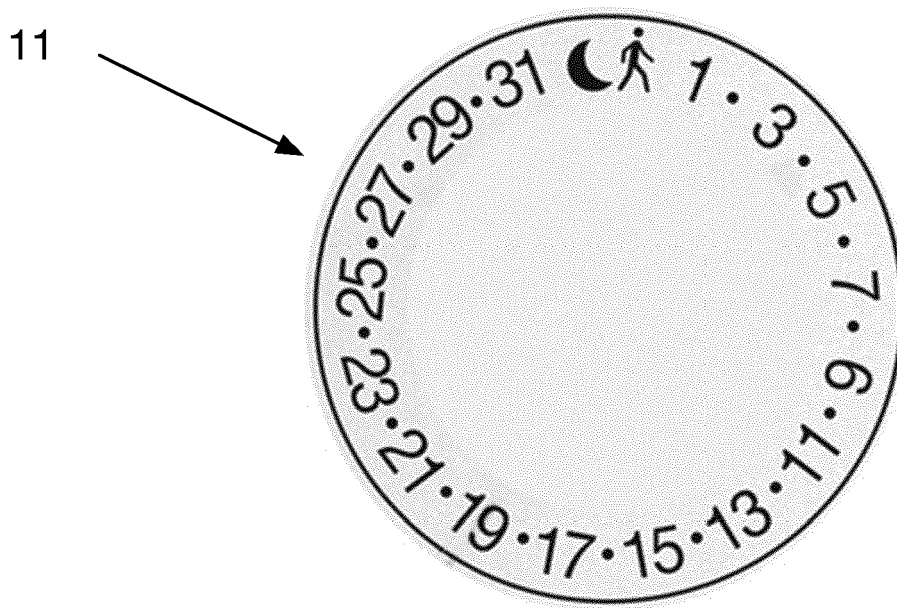
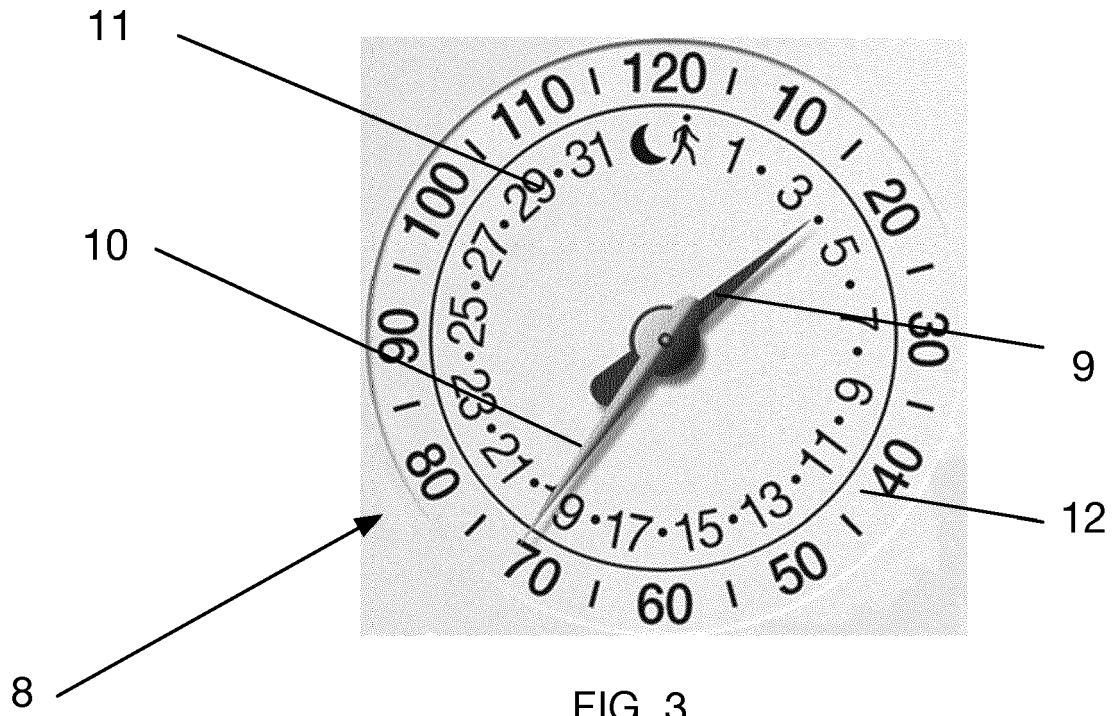

FIG. 2



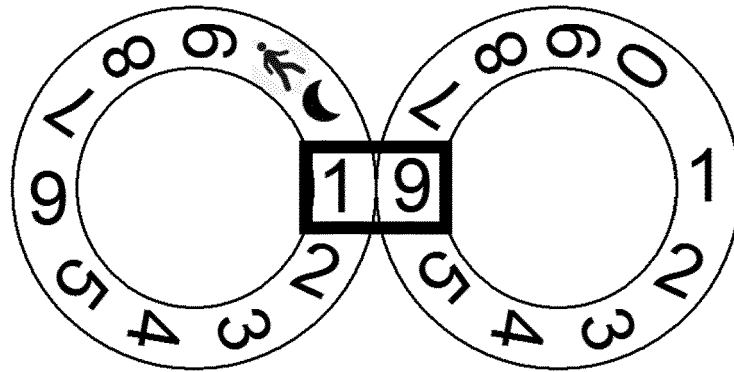

Fig. 18

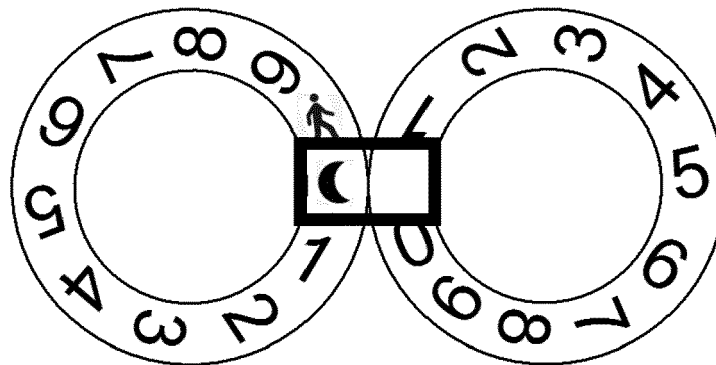

Fig. 19

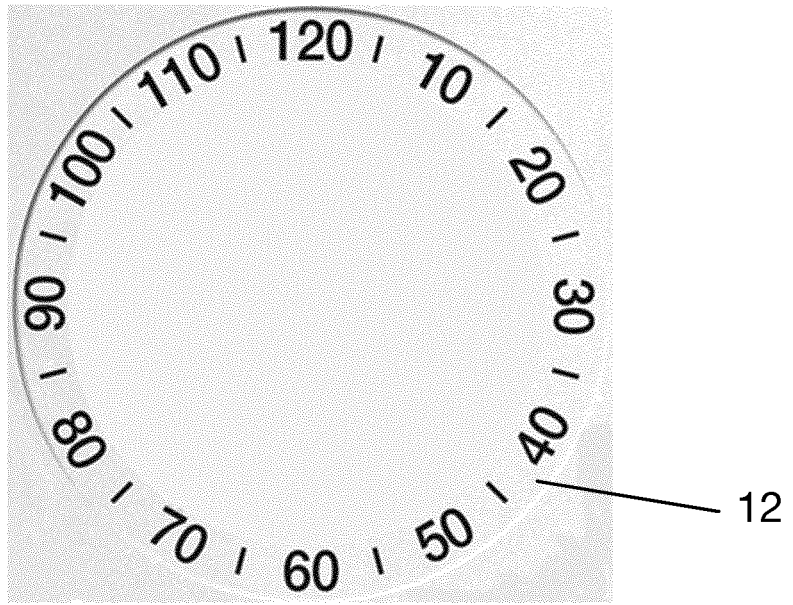

FIG. 5

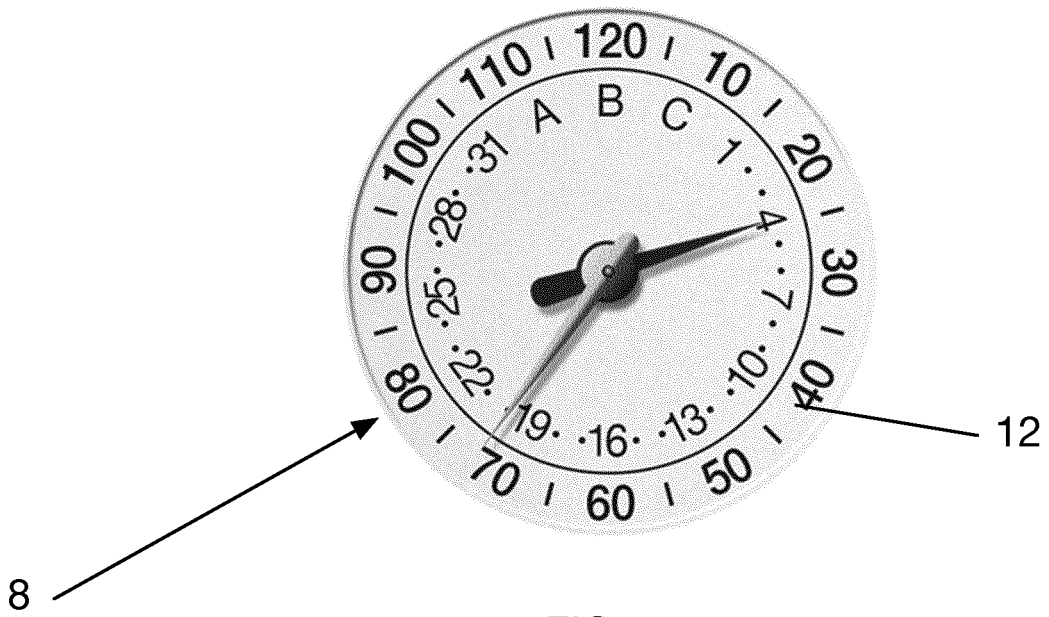

FIG. 6

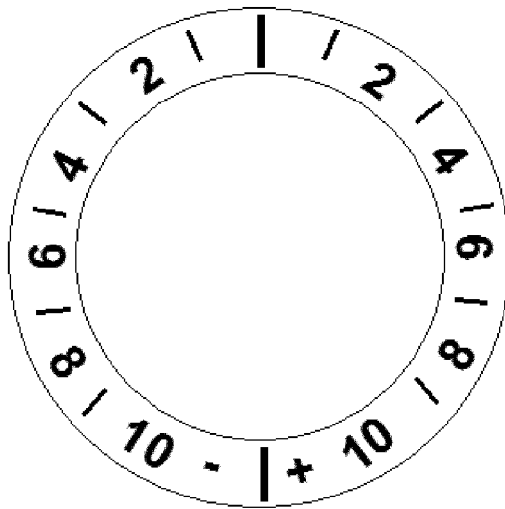
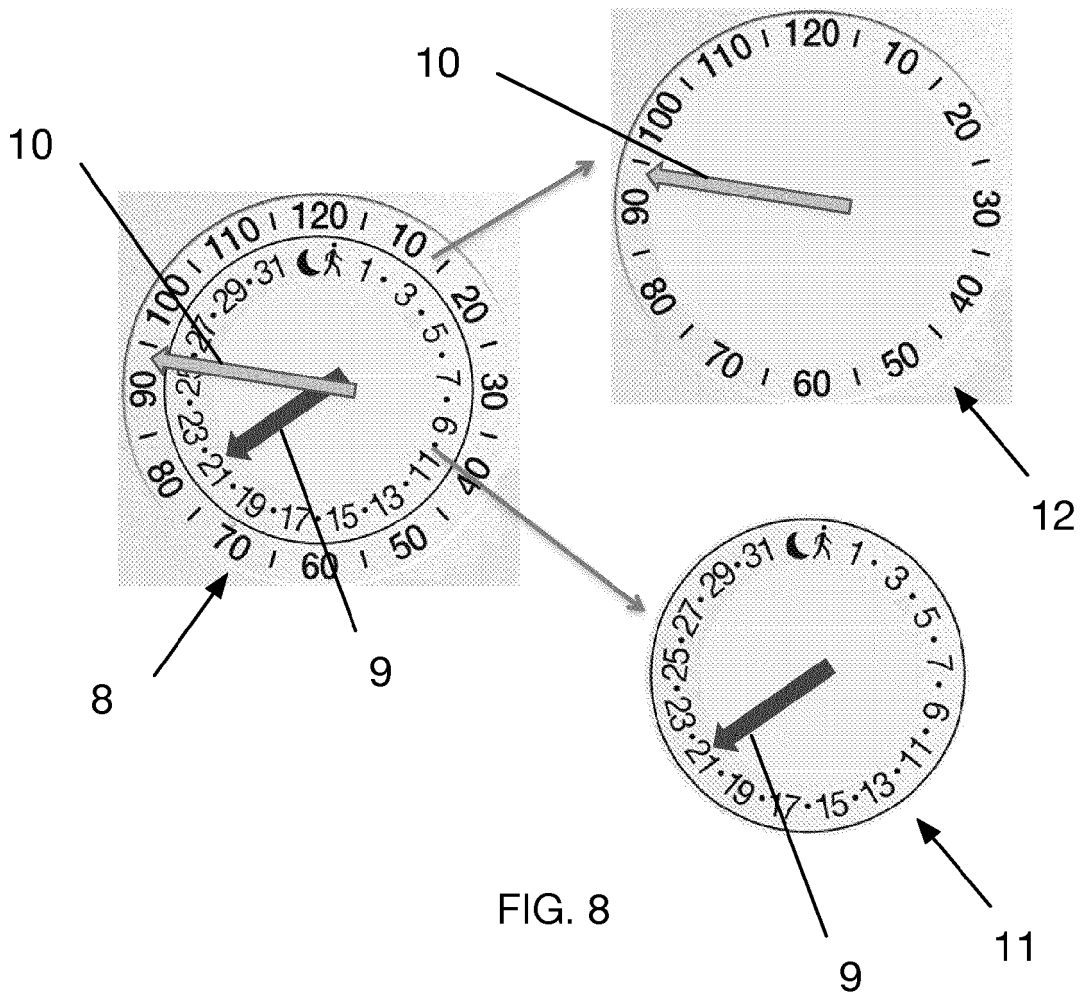

FIG. 7



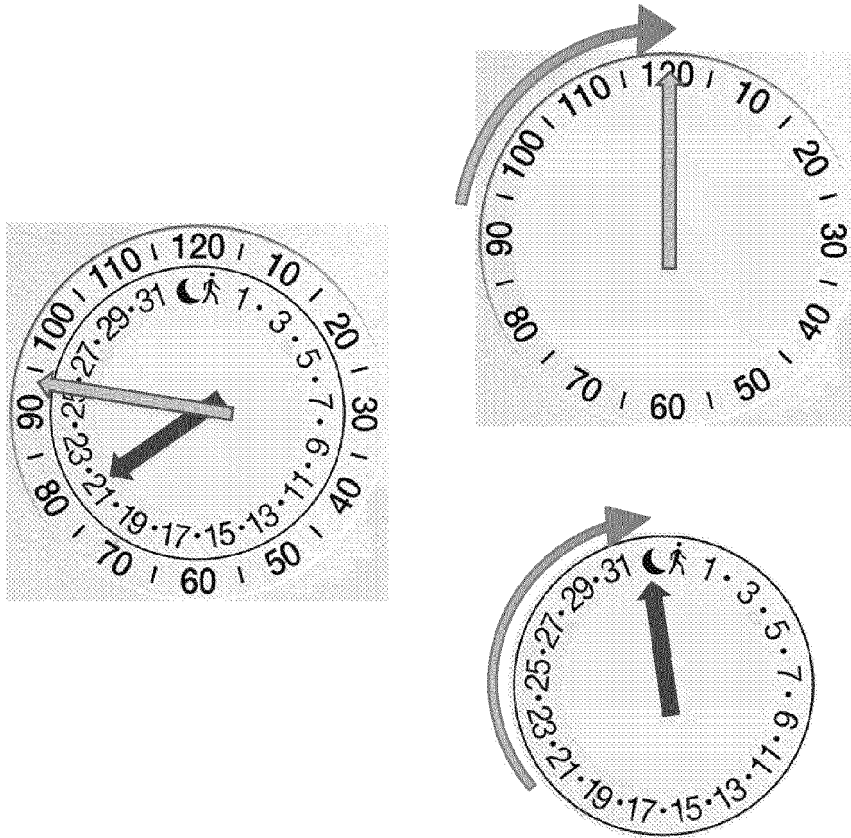

FIG. 9

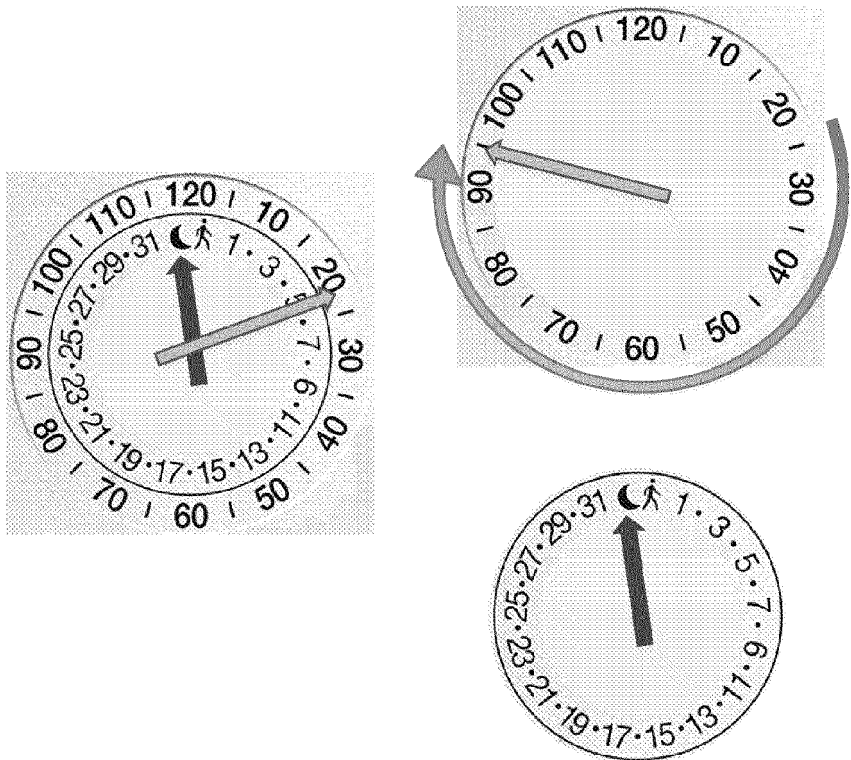

FIG. 10

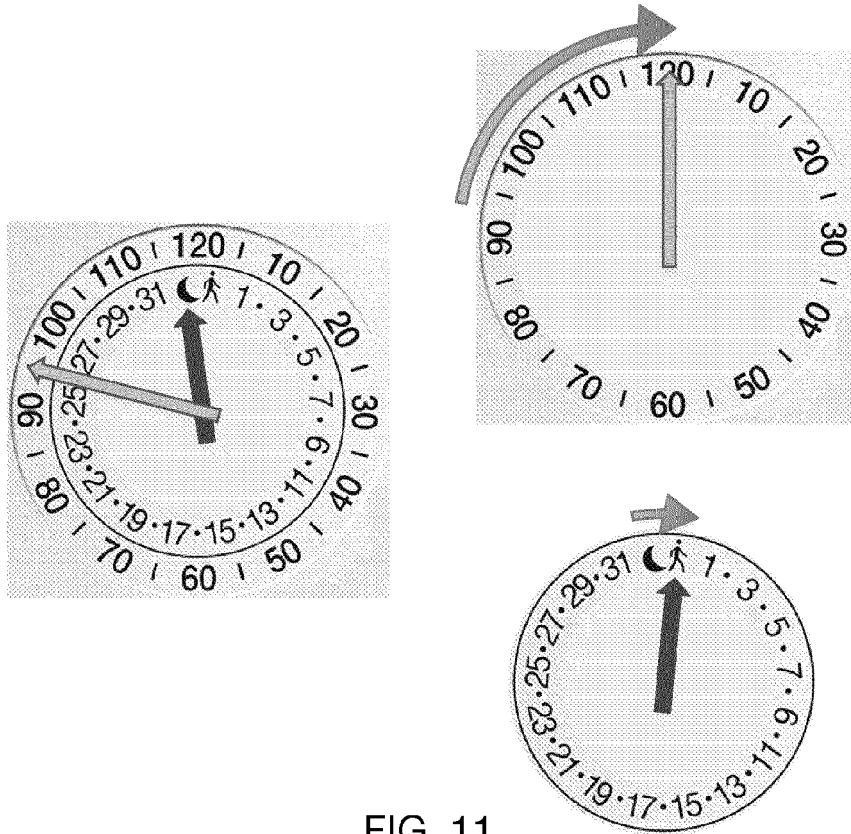

FIG. 11

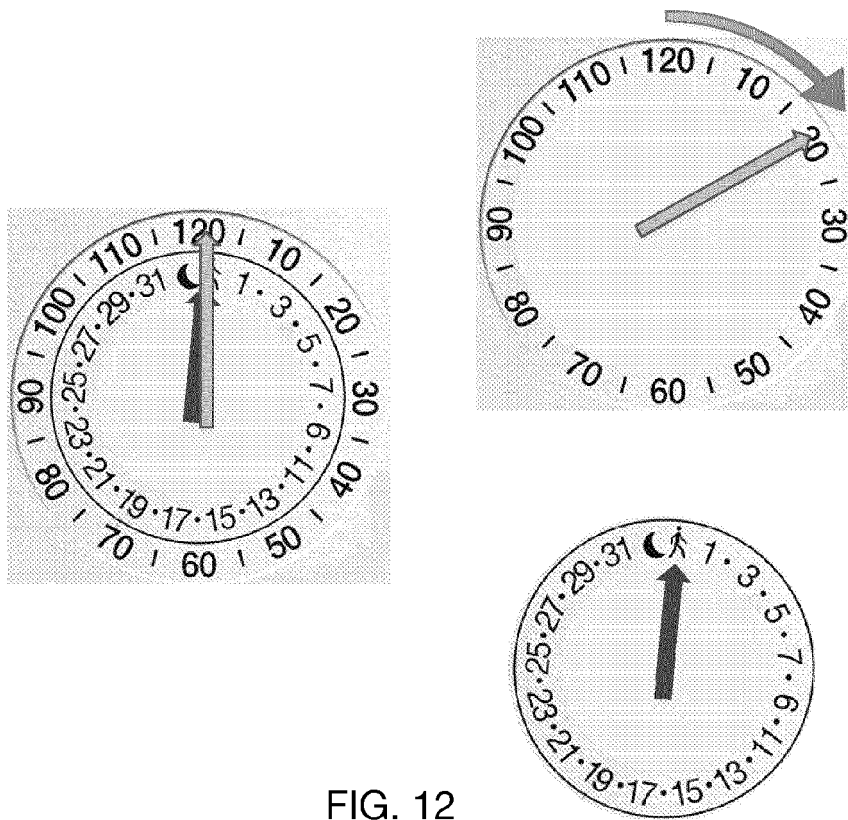

FIG. 12

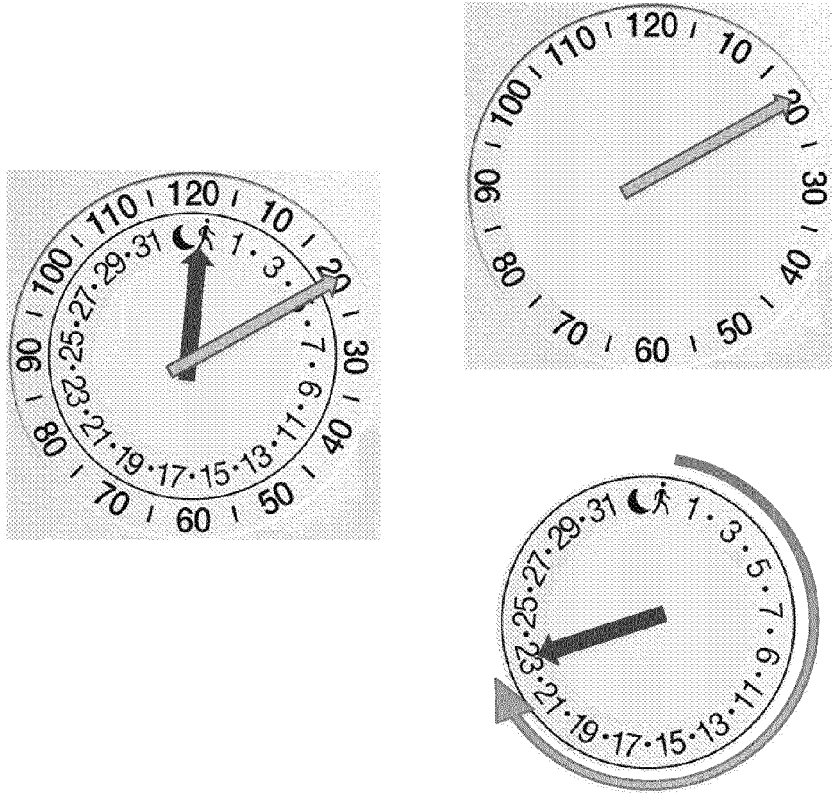

FIG. 13

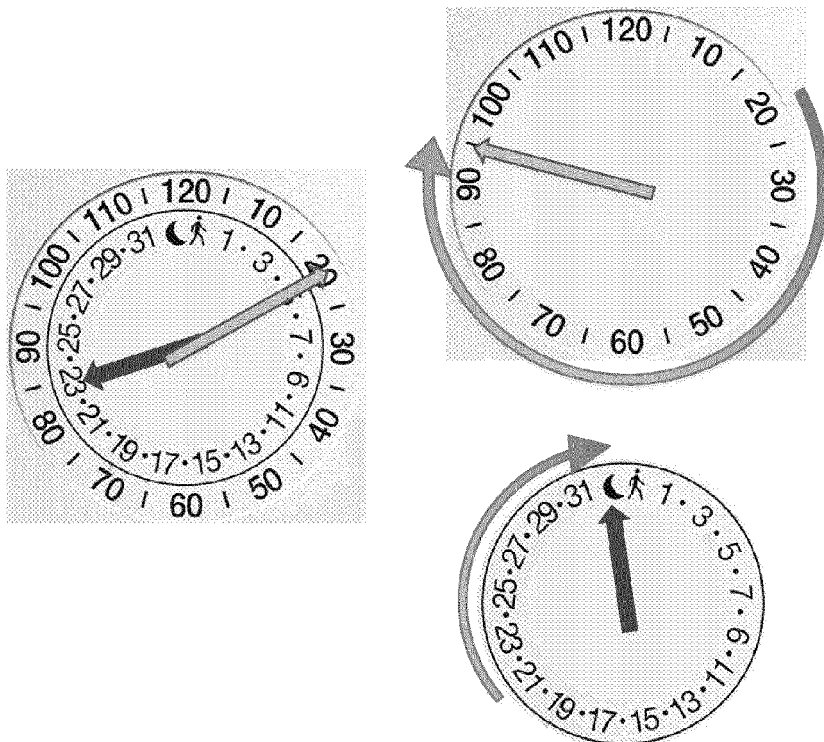

FIG. 14

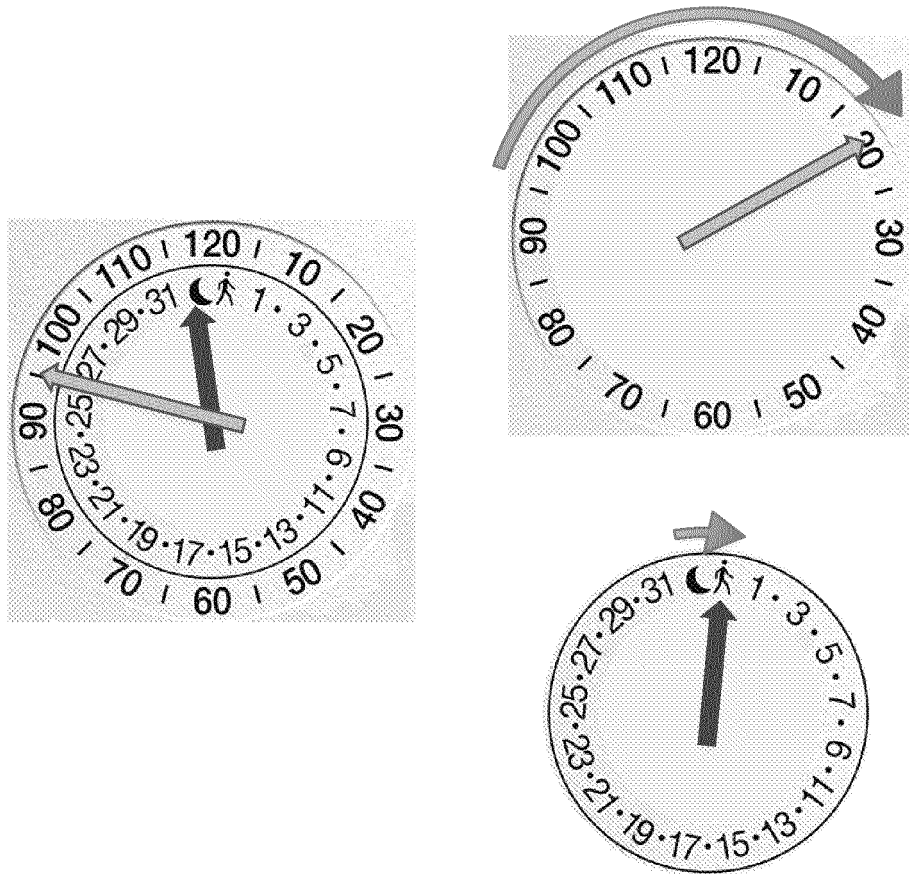

FIG. 15

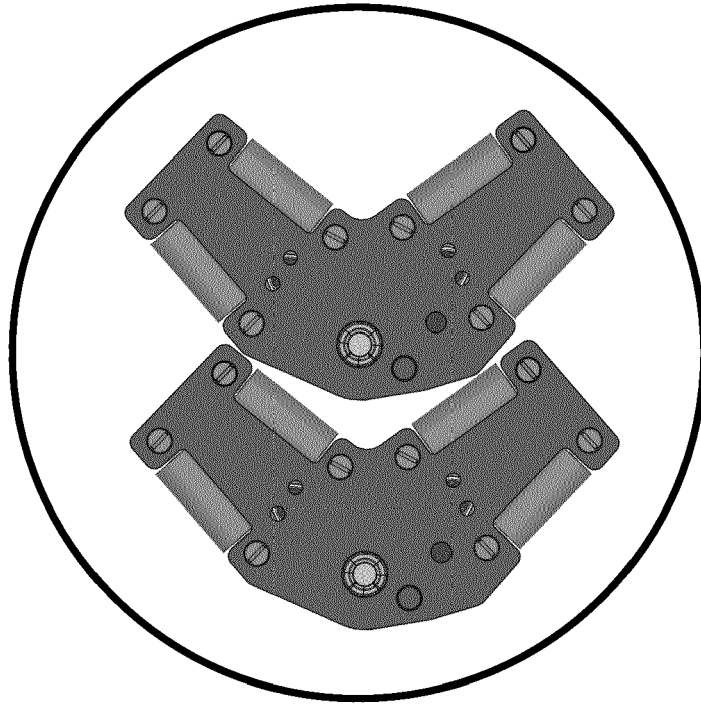

FIG. 16

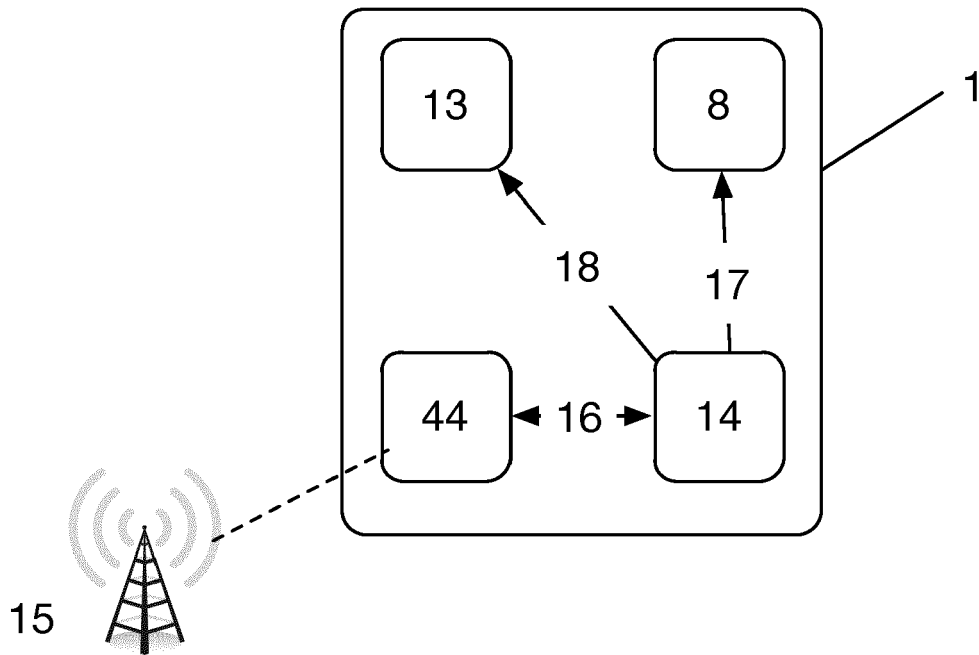

FIG. 17



EUROPEAN SEARCH REPORT

Application Number
EP 14 18 7207

5

10

15

20

25

30

35

40

45

50

55

DOCUMENTS CONSIDERED TO BE RELEVANT			
Category	Citation of document with indication, where appropriate, of relevant passages	Relevant to claim	CLASSIFICATION OF THE APPLICATION (IPC)
Y	US 2008/186809 A1 (OGASAWARA KENJI [JP]) 7 August 2008 (2008-08-07) * paragraphs [0144], [0169] - [0172]; figures 1,7 *	1-13	INV. G04C17/00 G04G21/02 G04G21/04
Y	US 2013/051189 A1 (SPRINGER SIMON [CH]) 28 February 2013 (2013-02-28) * paragraphs [0071] - [0073]; figures 1,2,4c *	1-13	
Y	US 2012/243379 A1 (BALLI FABIEN [CH]) 27 September 2012 (2012-09-27) * paragraphs [0039] - [0042]; figure 3 *	1	
			TECHNICAL FIELDS SEARCHED (IPC)
			G04B G04C G04G
The present search report has been drawn up for all claims			
Place of search The Hague		Date of completion of the search 25 June 2015	Examiner Mérिमèche, Habib
CATEGORY OF CITED DOCUMENTS X : particularly relevant if taken alone Y : particularly relevant if combined with another document of the same category A : technological background O : non-written disclosure P : intermediate document		T : theory or principle underlying the invention E : earlier patent document, but published on, or after the filing date D : document cited in the application L : document cited for other reasons & : member of the same patent family, corresponding document	

EPO FORM 1503 03/02 (P04C01)

ANNEX TO THE EUROPEAN SEARCH REPORT
ON EUROPEAN PATENT APPLICATION NO.

EP 14 18 7207

5 This annex lists the patent family members relating to the patent documents cited in the above-mentioned European search report.
The members are as contained in the European Patent Office EDP file on
The European Patent Office is in no way liable for these particulars which are merely given for the purpose of information.

25-06-2015

Patent document cited in search report	Publication date	Patent family member(s)	Publication date
US 2008186809 A1	07-08-2008	NONE	

US 2013051189 A1	28-02-2013	CN 102955422 A	06-03-2013
		EP 2562609 A1	27-02-2013
		JP 5580373 B2	27-08-2014
		JP 2013044753 A	04-03-2013
		KR 20130021327 A	05-03-2013
		US 2013051189 A1	28-02-2013
		US 2015131412 A1	14-05-2015

US 2012243379 A1	27-09-2012	CN 102598116 A	18-07-2012
		EP 2293286 A1	09-03-2011
		EP 2476112 A1	18-07-2012
		HK 1171282 A1	13-06-2014
		JP 5480385 B2	23-04-2014
		JP 2013504096 A	04-02-2013
		US 2012243379 A1	27-09-2012
		WO 2011026798 A1	10-03-2011
