

(19)



(11)

EP 3 034 303 B1

(12)

EUROPEAN PATENT SPECIFICATION

(45) Date of publication and mention of the grant of the patent:
11.12.2019 Bulletin 2019/50

(51) Int Cl.:
B41J 2/175^(2006.01)

(21) Application number: **15201911.3**

(22) Date of filing: **22.10.2010**

(54) FLUID CARTRIDGE

FLÜSSIGKEITSKARTUSCHE

CARTOUCHE DE FLUIDE

(84) Designated Contracting States:
AL AT BE BG CH CY CZ DE DK EE ES FI FR GB GR HR HU IE IS IT LI LT LU LV MC MK MT NL NO PL PT RO RS SE SI SK SM TR

(43) Date of publication of application:
22.06.2016 Bulletin 2016/25

(62) Document number(s) of the earlier application(s) in accordance with Art. 76 EPC:
14186874.5 / 2 826 630
10855127.6 / 2 588 320

(73) Proprietor: **Hewlett-Packard Development Company, L.P.**
Spring TX 77389 (US)

(72) Inventors:
 • **HARVEY, David C.**
Corvallis, OR Oregon 97330-4239 (US)

- **GONZALES, Curt**
Corvallis, OR Oregon 97330-4239 (US)
- **STATHEM, Ralph L.**
Lebanon, OR Oregon 97335 (US)
- **OLSEN, David**
Corvallis, OR Oregon 97330-4239 (US)
- **WELTER, David**
Corvallis, OR Oregon 97330-4239 (US)

(74) Representative: **Lawman, Matthew John Mitchell et al**
EIP
Fairfax House
15 Fulwood Place
London, WC1V 6HU (GB)

(56) References cited:
EP-A2- 1 122 078 EP-A2- 1 348 562
EP-A2- 1 815 994 GB-A- 2 316 657
US-A1- 2007 013 753 US-A1- 2008 168 481

EP 3 034 303 B1

Note: Within nine months of the publication of the mention of the grant of the European patent in the European Patent Bulletin, any person may give notice to the European Patent Office of opposition to that patent, in accordance with the Implementing Regulations. Notice of opposition shall not be deemed to have been filed until the opposition fee has been paid. (Art. 99(1) European Patent Convention).

Description

Background of the invention

[0001] Fluid cartridges are subassemblies to be exchanged with a corresponding fluid ejection assembly. A common fluid cartridge is an ink cartridge. A common fluid ejection assembly is a printer. In general, two types of ink cartridges can be distinguished. A first type consists of an integrated print head cartridge, wherein the cartridge comprises a print head. A second type consists of an individual ink container. An ink cartridge is connected to a receiving structure of a printer. The receiving structure and the ink cartridges are provided with the proper interfaces for guiding ink from the cartridge to the print head for printing. In addition to the ink interface, an air interface, a keying interface, an electrical interface and an alignment interface can be provided in the ink cartridge and its receiving structure. The air interface transports air to and from the cartridge, mostly for pressure control inside the cartridge. The keying interface ensures that the respective cartridge is seated in the proper ink cartridge receiving structure. The alignment interface ensures that the interfaces are well aligned for connection. The electrical interface sends electrical signals between a printer control circuit and the ink cartridge. The signals may relate to ink cartridge characteristics.

[0002] An extra lock is usually provided to maintain substantially air and liquid tight connections between the cartridge and the receiving structure. The extra lock should also maintain the electrical connection. A known locking technique involves the use of a bail to keep the cartridge sealed to the receiving bay. Another known locking technique uses a deforming snap finger that engages a notch to keep the cartridge sealed.

[0003] The known lock mechanisms tend to consume a relatively large amount of space within the printer. In addition, significant force may be needed to establish the lock. In some cases, the cartridge is inserted in an inclined orientation, after which it is rotated back to normal position to make the interfaces engage. This usually involves deflection of engaging elements so that improper interface connections, leakage, and material wear or damage are likely to occur.

[0004] European Patent Application Publication No. 1348562 A2 discloses an integrated printhead cartridge and a corresponding receiving structure. The receiving structure includes a hinging latch arm and a clamp structure to latch the cartridge. United States Patent Application Publication No. 2008/0168481 A1 describes a cartridge having a tray that is slidably mounted onto a base. European Patent Application Publication No. EP1122078 A2 discloses a replaceable ink container including a fluid interconnect, keying features, and a latch for securing the ink container to a receiving station. United States Patent Application Publication No. 2007/0013753 A1 discloses an ink container having an alignment pocket, a keying pocket, an air interface and

an ink interface in a lid. A container bay for receiving the container includes a pivoting latching member that encloses the container for latching the container in the bay. UK Patent Application Publication No. GB 2316657 A discloses an ink cartridge having guide ribs disposed on opposite sides, for guiding the ink outlet to the printers' ink inlet. European Patent Application Publication No. 1815994 A2 discloses a liquid container having a front surface having a first opening extending inward into the ink cartridge along a first line and a second opening extending inward into the ink cartridge along a second line approximately parallel to the first line. A guide groove for guiding a fixing pin is formed in a bottom surface of the liquid container.

Brief description of the drawings

[0005] For the purpose of illustration, certain embodiments of the present invention will now be described with reference to the accompanying diagrammatic drawings, in which:

Fig. 1 illustrates a diagram of an embodiment of a fluid ejection system, in front view;

Fig. 2 illustrates a diagram of the embodiment of the fluid ejection system of Fig. 1, in side view;

Fig. 3 illustrates a cross sectional side view of a part of an embodiment of a fluid ejection system with a fluid cartridge in a non-connected state;

Fig. 4 illustrates an embodiment of a detail of a receiving structure for a fluid cartridge, in front view;

Fig. 5 illustrates a perspective view of an embodiment of a fluid cartridge;

Fig. 6 illustrates another perspective view of the embodiment of the fluid cartridge of Fig. 5, clearly showing a guide track and a latch track;

Fig. 7 illustrates a cross sectional side view of the embodiment of the part of the fluid ejection system of Fig. 3 wherein the fluid cartridge is connected to the cartridge receiving structure;

Fig. 8 illustrates a flow chart of an embodiment of a method of connecting a fluid cartridge to a receiving structure;

Fig. 9 illustrates a flow chart a further embodiment of a method of connecting and disconnecting a fluid cartridge with respect to a receiving structure;

Fig. 10 illustrates a diagrammatic cross sectional bottom view of an embodiment of a fluid cartridge and a cartridge receiving structure, in a first stage of connecting the fluid cartridge, wherein the latch arrangement is made semi-transparent for reasons of illustration;

Fig. 11 illustrates a diagrammatic cross sectional bottom view of the embodiment of the fluid cartridge and the cartridge receiving structure of Fig. 10, in a second stage of connecting the fluid cartridge, wherein the latch arrangement is made semi-transparent for reasons of illustration;

Fig. 12 illustrates a diagrammatic cross sectional bottom view of the embodiment of the fluid cartridge and the cartridge receiving structure of Fig. 10 and 11, in a third stage of connecting the fluid cartridge, wherein the latch arrangement is made semi-transparent for reasons of illustration;

Fig. 13 illustrates a diagrammatic cross sectional bottom view of the embodiment of the fluid cartridge and the cartridge receiving structure of Fig. 10 - 12, in a final stage of connecting the fluid cartridge, wherein the latch arrangement is made semi-transparent for reasons of illustration;

Fig. 14 illustrates a diagrammatic cross sectional bottom view of the embodiment of the fluid cartridge and the cartridge receiving structure of Fig. 10 - 13, in a first stage of disconnecting the fluid cartridge, wherein the latch arrangement is made semi-transparent for reasons of illustration;

Fig. 15 illustrates a diagrammatic cross sectional bottom view of the embodiment of the fluid cartridge and the cartridge receiving structure of Fig. 10 - 14, in a second stage of disconnecting the fluid cartridge, wherein the latch arrangement is made semi-transparent for reasons of illustration.

Detailed Description

[0006] In the following detailed description, reference is made to the accompanying drawings. The embodiments in the description and drawings should be considered illustrative and are not to be considered as limiting to the specific embodiment or element described. Multiple embodiments may be derived from the following description and/or drawings through modification, combination or variation of certain elements. Furthermore, it may be understood that other embodiments or elements that are not literally disclosed may be derived from the description and drawings by a person skilled in the art.

[0007] In this description, reference may be made to a three dimensional space comprising an X, Y and Z-axis. The one dimensional insertion and ejection direction of the cartridge 3 is parallel to the Y-axis. The Y-axis is also referred to as a straight line Y.

[0008] Fig. 1 and 2 show a fluid ejection system 1. The fluid ejection system 1 comprises a fluid ejection device 2 and fluid cartridges 3. The fluid ejection device 2 may comprise a printer. The printer may be an inkjet printer, for example a thermal inkjet, a piezo inkjet, or a continuous inkjet printer. The fluid ejection device 2 comprises one or more receiving structures 4 for receiving and exchanging one or more corresponding fluid cartridges 3. Each cartridge 3 of the same fluid ejection device 2 may comprise a different fluid. If the fluid ejection device 2 is a printer, the fluid in each cartridge 3 may comprise ink of a specific color, for example a cyan, magenta, yellow, black and/or grey. The cartridges 3 are arranged to be exchanged with respect to the respective receiving structure 4.

[0009] The receiving structures 4 are arranged to connect the cartridge 3 to the print head 5. A fluid supply 6 is provided to receive fluid from the respective cartridges 3, and deliver the fluid to the print head 5. In the shown embodiment, the receiving structures 4 and the cartridges 3, when installed, are arranged off axis. The print head 5 may comprise a page wide array print head (PWA) or a scanning print head. The receiving structure 4 is arranged to establish a fluidic interface between the cartridge 3 and the print head 5, through the fluid supply 6. During printing a print medium 7 extends under the print head 5. In other embodiments (not shown), the receiving structures 4 and the cartridges 3, when installed, are arranged on a scanning axis. In further embodiments, the cartridge 3 comprises an integrated print head, wherein the fluid volume and the print head are integrated into one cartridge supply to be connected to the receiving structure 4.

[0010] The fluid ejection device 2 is provided with a control circuit 8 and a memory 9. The fluid cartridge 3 is provided with a cartridge electrical circuit 10, for example including a cartridge memory 11. The control circuit 8 is arranged to retrieve data from the cartridge electrical circuit 10. The data comprises certain cartridge characteristics, for example product characteristics, fluid type characteristics and/or fluid quantity characteristics.

[0011] Fig. 3 shows a receiving structure 4 and a fluid cartridge 3 in a position right before or after installation. At installation (Fig. 7), all interfaces of the receiving structure 4 and the fluid cartridge 3 are interconnected. The receiving structure 4 may comprise a slot shaped opening into which the cartridge 3 is inserted. A part of the receiving structure 4 may be arranged to guide the cartridge 3 into connection with the guide 17 for movement along straight line Y. The arrow A indicates an insertion movement of the cartridge 3, along the straight, one dimensional, line Y, represented by the Y-axis. Once the fluid cartridge 3 engages the guide 17, its insertion movement is substantially confined to movement along the straight line Y. In principle, there is substantially no movement along a Z and X-axis and there is substantially no rotational movement of the cartridge 3, during insertion and ejection along the guide 17. However, the skilled person will understand that a certain amount of play, margin or tolerance in the interfacing materials of the cartridge 3 and receiving structure 4, such as the guide 17, may be allowed. In one embodiment, the margin of deviation is approximately 3 millimeters or less, in a direction perpendicular to the straight line Y, and approximately 3° or less around the straight line Y, or the Z-axis or X-axis. These margins may still allow proper connection of the cartridge 3 to the receiving structure 4.

[0012] The receiving structure 4 comprises two fluidic interfaces. The fluidic interfaces include one first fluid pen 12 and one second fluid pen 13. The first fluid may be a print fluid such as ink. The second fluid may be a gas such as air. The pens 12, 13 are arranged to establish a fluidic connection with corresponding first and second

cartridge fluidic interfaces. The first and second cartridge fluidic interface may comprise a first and second socket 14, 15, respectively. The pens 12, 13 have central axes C1, C2, respectively, that are parallel to the Y-axis. In one embodiment (not shown), the receiving structure 4 has only one fluidic interface, for example a pen. In another embodiment (not shown), the receiving structure 4 has more than two such fluidic interfaces.

[0013] In an embodiment, the first fluid pen 12 comprises an ink pen. The first fluid pen 12 has a relatively small diameter at its mouth 16. The first fluid pen 12 has a longitudinal shape. The first fluid pen 12 has a truncated, conical shape. The first fluid pen 12 may be made of molded plastics. The receiving structure 4 comprises a guide 17 for guiding the cartridge 3 along the one dimensional direction Y at insertion and ejection. The guide 17 may be longer than the first fluid pen 12, or at least of approximately the same length, for proper insertion of the pen 12 in the corresponding socket 14, and to prevent breaking or bending the pen 12 at insertion or ejection. This allows the pen 12 to be made of relatively cheap molded plastics.

[0014] In an embodiment, the second fluid pen 13 comprises a gas interface for controlling a pressure in the inner volume of the fluid cartridge 3. The gas may comprise ambient air. In a further embodiment, the second fluid pen 13 is arranged to connect to the second socket shaped fluidic interface 15, which in turn may connect to a pressure bag in the inner volume of the cartridge 3. The second fluid pen 13 has a longitudinal shape. The second fluid pen 13 has a truncated, conical shape. The second fluid pen 13 may be made of molded plastics. The guide 17 may be longer than the second fluid pen 13, or at least of approximately the same length, for proper insertion of the second fluid pen 13 in the corresponding second fluidic interface 15, and to prevent breaking or bending the second fluid pen 13 at insertion or ejection. This allows the pen 13 to be made of relatively cheap molded plastics.

[0015] The guide 17 and/or the corresponding guide interface that confine the insertion and ejection movement of the cartridge 3 to one dimension. This allows relatively long and deep of the interfaces 12, 13 and 14, 15, respectively. The respective pen 12, 13 may have a length of at least 5 millimeter, or at least 10 millimeters. The corresponding socket 14, 15 may have a depth of at least approximately 3 millimeters, or at least approximately 5 millimeters, or approximately 10 millimeters.

[0016] In an embodiment, the receiving structure 4 comprises a connector circuit 18 for interconnecting the control circuit 8 of the fluid ejection device 2 with the cartridge electrical circuit 19. In Fig. 3, the backside of the connector circuit 18 is shown. In Fig. 4, an embodiment of a connector circuit 18 is shown in a plane formed by the X- and Z-axis. The connector circuit 18 comprises connector electrodes 20. The electrodes 20 may extend along a line P approximately parallel to the Z-axis, perpendicular to the straight line Y. When the cartridge 3 is

inserted or ejected along the straight line Y, the cartridge electrical circuit 19 moves along the electrodes 20 until they are connected. The connector circuit 18 is arranged to connect sideways to the cartridge electrical circuit 19, in a direction B transverse with respect to the straight line Y. In the drawings, the transverse direction B is parallel to the X-axis. In an installed condition of the cartridge 3, the connector circuit 18 and the cartridge electrical circuit 19 extend next to each other as seen from the direction of movement along the straight line Y. In the shown embodiment, the electrodes 20 comprise pins. The connector electrodes 20 are arranged to be moved in the transverse direction B. The electrodes 20 may comprise resilient members that are biased towards the cartridge electrical circuit 19, for electrical connection. The electrodes 20 are pushed backwards by the cartridge electrical circuit 19 during insertion of the cartridge 3. During insertion, the connector electrodes 20 may slide on the cartridge electrical circuit 19 until the cartridge 3 is locked in the receiving structure 4 and the electrodes 20 establish proper contact with the corresponding cartridge electrical circuit 19. At the same time, the resilient members push the electrodes 20 against the electrical circuit 19 for better electrical connection. When the cartridge 3 is again ejected out, the electrodes 20 again move outwards due to the resilient force.

[0017] The fluid ejection device 2 may comprise at least two different receiving keying interfaces 22. In an embodiment, each receiving structure 4 is provided with one specific receiving keying interface 22 that is different from the other receiving keying interfaces 22 of the other receiving structures 4. The receiving keying interface 22 corresponds to a particular ink color, for example cyan, magenta, yellow or black. In an embodiment, the fluid ejection device 2 comprises a specific receiving keying interface 22 for each particular fluid cartridge 3. In an embodiment, the fluid ejection device 2 comprises four receiving structure 2 with four respective receiving keying interfaces 22, each corresponding to a fluid cartridge 3 of a specific color having a corresponding cartridge keying interface 24.

[0018] The fluid ejection device 2 comprises receiving structures 4 having receiving keying interfaces 22 arranged to allow connection to a cartridge 3 with matching keying interfaces 24, and preventing connection with fluid cartridges 3 that are arranged with non-matching cartridge keying interfaces 24. For example, a first receiving keying interface 22 comprises a first notch 23 or cut out. A matching first cartridge keying interface 24 of a corresponding cartridge 3 comprises a corresponding inverse notch or cut out 25 that during insertion is not blocked by the first receiving keying interface 22, but is blocked when inserted in other receiving structures with other receiving keying interfaces 22. Likewise, the other cartridges 3 have a second, third, fourth, and/or further cartridge keying interface 24 that does not match the first receiving keying interface 22. The other second, third, fourth and/or further receiving keying interfaces do not match the first

cartridge keying interface 24. The keying interfaces 22, 24 prevent that ink colors of the respective cartridge 3 and receiving structures 4 do not match.

[0019] The keying interface 22 of the receiving structure 4 may be arranged next to the connector circuit 18. The corresponding keying interface 24 of the cartridge 3 may be arranged next to the cartridge electrical circuit 19. If keying interfaces 22, 24 match, they may engage sideways so that the circuits 18, 19 may be pressed into contact. If the keying interfaces 22, 24 do not match, no electrical contact can be established. On the one hand, no electrical contact is made between the connector circuit 18 and the cartridge electrical circuit 19 if the keying interfaces do not match. On the other hand, a proper contact between the interconnecting circuits 18, 19 is aided by the respective keying interfaces 22, 24 of the receiving structure 4 and the cartridge 3, respectively.

[0020] The guide 17 is arranged to guide the corresponding fluid cartridge 3 along the straight line Y. The guide 17 is arranged to engage a corresponding guide interface of the cartridge 3, for example a guide track 21. The guide 17 comprises a rail that extends parallel to the Y-axis. The guide 17 is longer than each of the pens 12, 13, to ensure proper alignment of the pens 12, 13 with the respective sockets 14, 15. This may provide for a good interconnection without leakage and may prevent deformation of the pens 12, 13. The guide 17 may comprise a T-rail for engaging the corresponding guide track 21 of the cartridge 3. A T-rail prevents rotation of the cartridge 3 around the straight line of movement Y, as well as around the other axes X, Z.

[0021] The receiving structure 4 comprises a latch arrangement 26 for locking the cartridge 3. In the shown embodiment, the latch arrangement 26 comprises a latch 27, arranged to be guided by a corresponding latch track 28 of the cartridge 3, between a locked and an unlocked position. The latch 27 may be arranged in the bottom of the receiving structure 4 for engaging the bottom 35 of the cartridge 3. The latch arrangement 26 may comprise a latch pivot 29 and a pivot arm 29B, to allow moving of the latch 27 between a locked and unlocked position, by pivoting around a pivot axis L. In the drawing, the pivot axis L is perpendicular to the straight line Y, parallel to the Z-axis. In an embodiment, the latch 27 is biased around the pivot axis L, so as to return to a starting position after ejection of the cartridge 3, and so as to engage respective latch track walls.

[0022] In an embodiment, the latch 27 comprises a pin. In a locked position, the latch 27 engages a corresponding latch stop 30 of the cartridge 3. In an unlocked position, the latch 27 is disengaged from the latch stop 30, so that the cartridge 3 can be released from the receiving structure 4. The latch 27 may extend on top of the pivot arm 29B. In an installed condition of the cartridge 3, the latch 27 extends in the latch track 28 while the pivot 29 and pivot arm 29B extend below the bottom 34 of the cartridge 3. In the shown embodiment, the latch arrangement 26 comprises latch boundaries 29C for limiting the

movement of the latch 27. In an embodiment, the latch boundaries 29C are arranged to engage and limit the movement of the latch pivot arm 29B. In an inserted condition of the cartridge 3 the latch boundaries 29C extend under the cartridge 3.

[0023] The cartridge receiving structure 4 comprises an ejector 31. Fig. 3 shows the ejector 31 in a decompressed state, after ejection or before insertion of the cartridge 3. Each receiving structure 4 comprises an ejector 31. The ejector 31 is biased in a direction parallel to the straight line Y. The ejector 31 may comprise a spring, or another resilient element, for example an elastomeric element. The spring may comprise a helical spring. When the fluid cartridge 3 is inserted and latched, the leading end 44 of the ejector 31 engages the front face 33 of the cartridge 3. In the shown embodiment, the central axis C2 of the spring is equal to the central axis C2 of the second fluid pen 13. The second fluid pen 13 extends within the spring. The helical spring is attached to a base 32 of the second fluid pen 13. The size of the ejector spring is such that in a decompressed condition of the helical spring (Fig. 3), the cartridge 3 can be taken out by hand.

[0024] The ejector 31 is arranged to push the cartridge 3 out of the receiving structure 4. In an installed and locked condition, the cartridge 3 is retained in the receiving structure 4 by the latch 27, while compressing the ejector 31. The latch 27 may be directed from a locked to an unlocked position by further pushing the cartridge 3 against the force of the compressed ejector 31 along the straight line Y, as will be explained further below. In an unlocked position, the latch 27 releases the cartridge 3, and the ejector 31 decompresses so as to eject the cartridge 3 in a direction out of the receiving structure 4 along the straight line Y.

[0025] Fig. 5 and 6 illustrate an embodiment of a fluid cartridge 3 in perspective view. Fig. 5 clearly depicts the front face 33, while Fig. 6 more clearly depicts the bottom face 35. In the shown embodiments, the fluidic, electric and keying interfaces are arranged on the front face 33. The guide interface, latch track 28 and latch stop 30 are arranged on the bottom face 35.

[0026] The fluidic interfaces of the cartridge 3 comprise a first cartridge fluidic interface for a first fluid and a second cartridge fluidic interface for a second fluid. In an embodiment, the first fluid comprises a print fluid or liquid such as ink, and the second fluid comprises a gas such as air. In the shown embodiment, the first and second cartridge fluidic interfaces comprise a first and a second socket 14, 15, respectively, arranged to receive and transport fluid from and/or to respective pens 12, 13, respectively. The first socket 14 may be connected to an inner volume of the cartridge 3. The second socket 15 may be connected to a pressure bag in the inner volume of the cartridge 3.

[0027] The depth of the respective socket 14, 15 is approximately the same as or shorter than a length of the guide 17 or guide track 21, to receive the respective

pen 12, 13 after engagement of the cartridge 3 with the guide 17, to ensure proper alignment with the respective pen 12, 13. The central axes C1, C2 of the sockets 14, 15 are parallel to the straight line Y. In an installed condition of the cartridge 3, the central axes C1, C2 of the sockets 14, 15 are approximately the same as the central axes C1, C2 of the respective receiving fluidic interfaces 12, 13.

[0028] The cartridge 3 may comprise an ejector alignment interface 36 on the front face 33. In an embodiment, the ejector alignment interface 36 is arranged near and/or around one of the cartridge fluidic interfaces, which in the shown embodiment are arranged as sockets 14, 15. In the shown embodiment, the ejector alignment interface 36 is arranged around the second socket 15, having the same central axis C2 with the second socket 15, and in an inserted condition of the cartridge 3, the same central axis C2 as the second pen 13. In the shown example, the ejector alignment interface 36 comprises a ring, for example in the shape of a ridge or flange around the second socket 15, for engaging the inner circumference of the leading end 44 of the spring shaped ejector 31, for aligning and maintaining the ejector 31 in position when engaging the cartridge 3.

[0029] The first socket 14 comprises seal ring 37 for receiving the first pen 12. The seal ring 37 comprises resilient material, for example elastomeric material, to at least substantially fluid tightly enclose the first fluidic pen 12, in a connected condition of the first pen 12. As will be explained further below, at an insertion and ejection stage, the pen 12 is inserted further inwards into the first socket 14, as compared to a position wherein the pen 12 is connected for printing. Therefore the seal ring 37 is arranged to allow further deformation, to allow such further insertion of the first pen 12. The inner diameter of the seal ring 37 is such that it fluid tightly encloses the first pen 12 from a narrow portion of the conical shape of the pen 12 up to a wider portion. For example, the pen 12 may have a smallest diameter of approximately 2,0 and a largest diameter of approximately 2,3 millimeter along the coned shape. In other embodiments the pen 12 may have a smallest diameter of at least approximately 1,5 and/or a largest diameter of approximately 3,5 millimeter or less along the coned shape of the pen 12. Again further embodiments may have smaller and/or larger diameters, respectively.

[0030] The seal ring 37 is arranged to fluid tightly enclose the first pen 12 along a substantial part of the length of the first pen 12. In an embodiment, the inner diameter of the seal ring 37 is approximately 1,2 millimeters. Depending on the diameter of the pen 12, in other embodiments the inner diameter of the seal ring 37 may be between approximately 0,6 and approximately 3,0 millimeters. The inner diameter of the seal ring 37 may stretch while maintaining its fluid tight pen enclosing characteristics when the pen 12 slides through the seal ring 37, for example at least approximately 0,3 millimeters, or in another embodiment at least approximately 0,6 mil-

limeters, or in another embodiment at least approximately 1,6 millimeters. In the shown embodiment, the seal ring 37 comprises a tapering receiving mouth 37B for aligning the first pen 12 at insertion. In the shown embodiment, the seal ring 37 comprises bumps 37C, arranged to prevent that the seal ring 37 sticks against an opposite engaging surface, for example at insertion in the receiving structure and/or at manufacture.

[0031] The cartridge 3 comprises an electrical circuit 19 (Fig. 3). In the shown embodiment, the electrical circuit 19 is sunken with respect to the front face 33, so that electrical contact with the connector circuit 18 is made only after the other interfaces are connected. In an embodiment, this may prevent that a printer receives electrical signals before the fluidic interfaces 12, 14, 13, 15 are connected. Such electrical signals sometimes trigger a printer to actuate a printhead 5 and/or cartridge 3, which may be prevented by certain embodiments of this disclosure.

[0032] The cartridge electrical circuit 19 is arranged to connect sideways, when inserted in the receiving structure 4. In connected condition, the connector circuit 18 extends at least partly within the cartridge 3. For example, the cartridge electrical circuit 19 comprises electrodes 38 extending in one plane, approximately perpendicular to the front face 33 of the cartridge 3, and parallel to the insertion direction, and/or a plane formed by the Z-axis and Y-axis. In an embodiment, the electrodes 38 of the cartridge electrical circuit 19 extend along a line PP that is approximately parallel to the Z-axis and/or the front face 33, in an installation position of the cartridge 3. The line PP extends behind the front face 33. The electrodes 38 of the cartridge electrical circuit 19 are arranged to connect to the corresponding electrodes 20 of the connector circuit 18. The line PP that extends through the electrodes 38 of the cartridge 3 is parallel to the line P (Fig 4) that extends through the electrodes 20 of the connector circuit 18, in an installed condition of the cartridge 3. In an installed condition, the connector circuit 18 extends at least partly through or behind the front face 33 of the cartridge 3, for connection with the cartridge electrical circuit 19.

[0033] In an embodiment, the cartridge 3 comprises a cartridge keying interface 24 for preventing connection to a receiving structure 4 that is arranged with a non-matching keying interface 22. In the shown embodiment, the cartridge keying interface 24 comprises a cut out 25. In other embodiments, the cartridge keying interface 24 may comprise a protrusion, and in again other embodiments it may comprise both. The cartridge keying interface 24 is arranged to block further insertion of the cartridge 3 if the receiving keying interface 22 does not match. The cartridge keying interface 24 is arranged to block insertion of the connector circuit 18 into the cartridge 3 if the receiving keying interface 22 does not match, so that electrical connection with the cartridge electrical circuit 19 will fail.

[0034] The keying interfaces 22, 24 may be arranged

to provide additional alignment of the cartridge 3 with respect to the receiving structure 4, in addition to the guide 17, for example preventing rotation around the straight line of movement Y. Furthermore, if the keying interfaces 22, 24 of the receiving structure 4 and the cartridge 3 match, the keying interfaces 22, 23 may engage due to their corresponding shape, so that the circuits 18, 19 are interconnected properly.

[0035] In some embodiments, the cartridges 3 are not provided with a keying interface 24 so that the cartridges 3 may match any of the receiving structures 4 of the fluid injection device 1, and the circuits 18, 19 interconnect, regardless of the receiving keying interface 24.

[0036] The cartridge 3 comprises a guide interface for cooperation with the guide 17 of the receiving structure 4. In the shown embodiment, the guide interface comprises a guide track 21. The guide interface is arranged for guiding the cartridge 3 along a straight line Y for connecting the interfaces. The guide interface may have a guide engaging surface that extends parallel to said straight line Y.

[0037] The guide track 21 is arranged for engaging the guide 17. The guide track 21 may be arranged to guide a corresponding T-rail guide 17. In the shown embodiment, the guide track 21 comprises a T-shaped cut out. The guide track 21 comprises flanges 39 for engaging under the wings 17B (Fig. 3) of the T-rail guide 17. The guide track 21 may comprise a tapered opening 40 for facilitating easy reception of the T-rail guide 17. The flanges 39 may be tapered near the opening 40. The guide track 21 may further comprise a guide stop 45.

[0038] The bottom 35 of the cartridge 3 further comprises a latch track 28. The guide track 21 and the latch track 28 may comprise one integral cut out in the bottom 35 of the cartridge 3. The bottom 35 may comprise an integrally molded plastic shape.

[0039] The cartridge 3 comprises a latch track 28 and a latch stop 30. The latch track 28 is arranged to move the latch 27 with respect to the latch stop 30. Once the latch 27 engages the latch stop 30, the cartridge 3 is retained. The position of the latch stop 30 may determine the location of the cartridge interfaces with respect to the receiving structure interfaces, along the straight line Y.

[0040] The latch track 21 comprises a locking track 28A and an unlocking track 28B. The locking track 28A may be fully or partially different from the unlocking track 28B. The latch stop 30 is arranged between the locking track 28A and the unlocking track 28B, so that the latch 27 is guided on one side 28A of the latch stop 30 during insertion, and on an opposite side 28B at ejection. At insertion, the latch 27 is guided by the locking track 28A. The locking track 28A may comprise a latch guiding surface 46 of the latch stop 30, for guiding the latch 27 on the correct side of the latch stop 30. The locking track 28A may further comprise a latch guide wall 47, at the end of the locking track 28A. The latch guide wall 47 is arranged to receive the latch 27 at the end of the locking track 28A, and direct the latch 27 to the latch stop 30. The latch stop

30 comprises a latch stop wall 49 and a latch abutment 50. The latch guide wall 47 is arranged to guide the latch 27 into an engaging locked position with the latch stop wall 49 (Fig. 13). The abutment 50 comprises a protrusion in the stop wall 49 for keeping the latch 27 from sliding off the latch stop wall 49. In the locked position, the latch 27 engages the abutment 50. In the locked position, the ejector 31 is compressed and pushes the cartridge 3 so that the latch stop 30 is pushed against the latch 27.

[0041] Furthermore, the unlocking track 28B comprises a latch re-direct wall 48. The latch re-direct wall 48 is arranged to receive the latch 27 when the latch stop 30 and latch track 28A are pushed inwards, and to guide the latch 27 into the unlocking track 28B for ejection, out of the latch stop engagement position. At ejection, the latch 27 passes the opposite side of the latch stop 30, with respect to insertion. The latch re-direct wall 48 may be arranged at the end of the latch track 28. Once the latch 27 is in an unlocked position, the ejector 31 ejects the cartridge 3 so that it can be taken out manually.

[0042] In an embodiment, the latch track 28 comprises audible and/or tactile feedback members. The latch 27 may be biased around its pivot axis L. The latch 27 may slide against latch track walls while the latch 27 travels through the latch track 28. For example, one or more latch track walls may comprise one or more feedback members such as ledges to provide for audible and/or tactile feedback while the latch 27 travels in the latch track 28. The feedback members may be provided near the latch guide wall 47, from where latch 27 will move into a locked position if the cartridge 3 is released. When receiving audible and/or tactile feedback, a user may know that the cartridge 3 may be released and that it is locked to the receiving structure 4. Another feedback member may be provided near the latch re-direct wall 48 for indicating an unlocking of the cartridge 3.

[0043] Fig. 7 shows a cross section of a part of the fluid ejection system 1, wherein the fluid cartridge 3 and the receiving structure 4 are connected. The ejector 31 is compressed and pushes the cartridge latch stop 30 against the latch 27. The cartridge 3 is further held in place by the guide 17. The pens 12, 13 extend largely within the respective sockets 14, 15 for transporting the respective fluids between the cartridge 3 and the fluid ejection device 2.

[0044] The electrodes 20, 38 of the connector circuit 18 and the cartridge electrical circuit 19, respectively, interconnect sideways. For example, the electrodes 20, 38 interconnect along a line P or PP that is parallel to the Z-axis, and/or in a plane that is parallel to the plane formed by the Y-axis and the Z-axis. Since the cartridge electrical circuit 19 is sunken with respect to the front face 33 of the cartridge 3, the connector circuit 18 and the cartridge electrical circuit 19 interconnect within the outer circumference of the cartridge 3, behind the front face 33. In an installed condition, the connector circuit 18 extends at least partly within the cartridge 3. In an embodiment, the connection between the connector cir-

cuit 18 and the cartridge electrical circuit 19 is established behind and/or next to a cartridge keying interface 24, within the cartridge 3.

[0045] In an embodiment, the cartridge 3 comprises at least one finger engagement surface 51 to facilitate and indicate manual handling of the cartridge 3, for example when inserting or taking out the cartridge 3. The finger engagement surface 51 may comprise one or a combination of an inwards curve, one or more ribs, a cut out, etc. The finger engagement surface 51 may be arranged on the top face 53 of the cartridge 3, and close to the back face 34. As illustrated in the shown embodiment, in an installed condition of the cartridge 3, the receiving structure 4 largely covers the finger engagement surface 51. After ejection, the finger engagement surface 51 is visible and free to be engaged for taking out the cartridge 3.

[0046] In an embodiment, the cartridge 3 comprises a finger push surface 52 to indicate that the cartridge 3 needs to be pushed into the receiving structure 4, for both locking and unlocking of the cartridge 3. The finger push surface 52 may comprise one or a combination of an inwards curve, one or more ribs, a cut out, etc. The finger push surface 52 is arranged in the back face 34. In an installed condition of the cartridge 3, the back face 34 and the finger push surface 52 are visible outside of the receiving structure 4. Although the finger push surface 52 may have a predetermined location on the back face 34, an aspect of certain embodiments of this disclosure is that the cartridge 3 may be pushed on any location of the back face 33 for proper connection of the interfaces, because guide 17 may guide the cartridge 3 along the straight line Y, irrespective of a specific pushing location or inclination.

[0047] Fig. 8 shows an embodiment of a method of connecting a fluid cartridge 3 to a receiving structure 4 in a flow chart. In a first stage 800 of such method, a fluid cartridge 3 is inserted in a receiving structure 4. The movement is confined to one dimension, that is, the cartridge 3 is moved along the straight line Y, as indicated by stage 810. At the end of the one dimensional movement, a fluidic connection is established between the cartridge 3 and the fluid ejection device 2. In a stage 820, the latch 27 is guided into the locked position by the movement along the straight line Y. The latch 27 maintains the fluidic connection. Stage 810 and 820 may occur simultaneously. In a stage 830, fluid may flow through the connected fluidic interfaces, for example for fluid ejection.

[0048] Fig. 9 shows a further embodiment of a method of connecting a fluid cartridge 3 to a receiving structure 4 in a flow chart. Fig. 10 - 15 illustrate sequential positions of the cartridge 3 with respect to the latch arrangement 26, corresponding to some of the stages 900 - 914 of Fig. 9.

[0049] In a stage 900, the cartridge 3 is manually inserted into the receiving structure 4. Fig. 10 corresponds to stage 900, wherein the position of the cartridge 3 with respect to the receiving structure 4 and the latch arrange-

ment 26 are illustrated. In a next stage 901, the guide track 21 engages the guide 17. By further pushing the cartridge 3 into the receiving structure 4, the guide 17 guides the cartridge 3 along the straight line Y, in the direction of the ejector 31. In a further stage 902, the latch 27 engages the latch track 28. The latch 27 is guided along the locking track 28A, as illustrated by Fig. 11. The pivot arm 29B pivots around pivot axis L (Fig. 3), to allow the latch 27 to be guided by the walls of the locking track 28A. In stage 903, the ejector 31 engages the front face 33 of the cartridge and is compressed. The ejector 31 may engage the ring 36 that is provided around a second pen receiving socket 15. Said stages 901 - 903 may take place simultaneously.

[0050] In the embodiment shown in Figs. 9 - 15, the cartridge 3 and the receiving structure 4 have matching keying interfaces 22, 24. In a stage 904, the fluidic interfaces 12, 13, 14, 15 are interconnected and the keying interfaces 22, 24 of the receiving structure 4 and the cartridge 3 match. The matching keying interfaces 22, 24 allow the cartridge electrical circuit 19 and the connector circuit 18 to interconnect. After the key match, in stage 905, the electrical connection between the circuits 18, 19 is established. The control circuit 8 receives a corresponding signal that the electrical connection is established. The established electrical connection implies that the fluidic connections are also established.

[0051] In a stage 906, the user pushes the cartridge 3 in until receiving a tactical and/or audible feedback. For example, the latch 27 engages the end 47 of the latch track 28 and/or the guide stops 45 engage an end of the guide 17 and/or the ejector 33 cannot be compressed further. In the corresponding Fig. 12 it is shown that the latch 27 engages the end of the latch track 28, in this embodiment the latch 27 engages the latch guide wall 47 for directing the latch 27 in a locked position when released. In a stage 907, the user will manually release the cartridge 3. In a stage 908, the ejector 31 decompresses, pushing the cartridge 33 backwards until the latch 27 engages the latch stop 30. As can be seen from corresponding Fig. 13, the latch 27 retains the cartridge 3 by engaging the latch stop wall 49. The latch 27 is held in position by the abutment 50. The stages 904 and 905 of the key match and electrical connection, and the stages 906 - 908 of the latch lock may take place approximately simultaneously.

[0052] If the cartridge 3 is not pushed in correctly, the fluidic and/or other interfaces may not have been properly connected. In such case, the latch 27 may not reach the latch guide wall 47 and does not reach the locked position. Then, the cartridge 3 will automatically be pushed out by the ejector 31, before any electrical and/or fluidic connection is made.

[0053] In a stage 909, the fluid ejection system 1 prints by retrieving the first fluid from the cartridge 3, through the first fluidic interfaces 12, 14. After printing, for example when the cartridge 3 is substantially empty, the cartridge 3 may be ejected for replacement. In a stage 910,

a user pushes the cartridges 3 in the direction of the ejector 31. By pushing the cartridge 3, the latch 27 may engage the latch re-direct wall 48. In a next stage 911, the latch 27 is guided into an unlocked position, for example by the latch re-direct wall 48 (Fig. 14). In the unlocked position, the cartridge 3 is no longer retained by the latch 27. In a stage 912, a user may manually release the cartridge 3. In a stage 913, the ejector 31 decompresses, ejecting the cartridge 3 (Fig. 15). Ejection is made possible since the cartridge 3 is no longer retained (Fig. 15). In stage 914, the user takes the cartridge 3 out of the receiving structure 4.

[0054] As described, the cartridge 3 may comprise a first fluidic interface 14 a second fluidic interface 15 an electrical interface 19, an ejector alignment interface 36, and/or a keying interface 24, which are arranged in the front face 33. The guide interface is arranged in the bottom face 35, having a receiving opening 40 near the front face 33. Hence, the interfaces are arranged to engage near the front surface 33 of the cartridge 3. In the shown embodiment, the keying interface 24 and the electrical interface 19 are arranged near the top surface 53, the second fluidic interface 15 and the ejector alignment interface 36 are arranged near the middle of the front surface 33, and the first fluidic interface 14 and the guide receiving opening 40 are arranged near the bottom face 35. The interfaces are relatively evenly distributed over the front face 33, providing for a relatively even distribution of the connecting forces of the respective interfaces, and relatively low total connection force, for example around 14 Newton or less. In the latch and guide mechanisms of the fluid ejection system 1, no deformation of latch or guide parts is necessary. A relatively light and simple push is sufficient for establishing a secure lock. Furthermore, the guide 17 allows for a user to push on any location of the back face 34 of the cartridge 3 for establishing all connections in one direction Y.

[0055] The cartridge 3 and receiving structure 4 may be relatively thin, consuming just a small volume of the printer. The cartridge motion track also consumes relatively little space because it comprises a straight line Y. Moreover, the cartridge 3 may be released using the same push motion in the same direction Y. If the cartridge 3 is not properly connected, for example fluidically and/or electrically, the cartridge 3 is automatically pushed out by the ejector 31.

[0056] The above description is not intended to be exhaustive or to limit the invention to the embodiments disclosed. Other variations to the disclosed embodiments can be understood and effected by those skilled in the art in practicing the claimed invention, from a study of the drawings, the disclosure, and the appended claims. In some embodiments, mechanical inversions may be applied with respect to the shown embodiments. For example, the latch track 28 may be provided on the receiving structure 4, while the latch arrangement 26 may be provided in the cartridge 3. The first and second fluidic interfaces of the cartridge 3 may comprise pens, while

the corresponding first and second fluidic interfaces of the receiving structure 4 may comprise sockets.

[0057] The indefinite article "a" or "an" does not exclude a plurality, while a reference to a certain number of elements does not exclude the possibility of having more elements. A single unit may fulfil the functions of several items recited in the disclosure, and vice versa several items may fulfil the function of one unit.

Claims

1. A method of connecting a fluid cartridge (3) to a fluid cartridge receiving structure (4), the fluid cartridge (3) comprising a first fluidic interface (14), a second fluidic interface (15) and an electrical interface (10,19), wherein these interfaces are arranged in a front face (33), and the fluid cartridge receiving structure (4) comprising corresponding first (12) and second (13) fluidic interfaces and an electrical connector circuit (18),

the method comprising:

inserting the fluid cartridge (3) along a straight line (Y) with respect to the fluid cartridge receiving structure (4) by guiding the fluid cartridge (3) using a guide track (21) arranged on a bottom face of the fluid cartridge (3) and extending parallel to the straight line, to establish a fluid connection between the first fluidic interfaces (12,14), a fluid connection between the second fluidic interfaces (13,15), and electrical connection between the electrical interface (10,19) and the electrical connector circuit (18), and by said movement along the straight line, guiding a latch (27) of the cartridge receiving structure (4) into a locked position, for maintaining the fluid connection, using a latch stop (30) and a latch track (28) which are arranged on the bottom face of the fluid cartridge (3), to guide and retain the latch (27) of the cartridge receiving structure (4).

2. The method of claim 1, comprising:

compressing an ejector spring (31) when inserting the fluid cartridge (3), maintaining the compressed condition of the ejector spring (31) when the latch (27) is locked, and ejecting the fluid cartridge (3) by decompression of the ejector spring (31) by unlocking the latch (27).

3. The method of claim 2, wherein the fluid cartridge (3) comprises a first fluidic interface (14) that is a first socket, and a second fluidic interface (15) that is a

second socket, wherein a ring shaped ejector alignment interface (36) is arranged around the second socket (15), wherein the inner circumference of a leading end (44) of the ejector spring (31) is engaged by the ring shaped ejector alignment interface (36), for aligning and maintaining the ejector spring (31) in position when engaging the fluid cartridge (3).

4. The method of one of claims 1 to 3, wherein the guide track (21) comprising a T-shaped cut out for guiding a corresponding T-rail of the cartridge receiving structure (4).
5. The method of claim 1 or 2, wherein the cartridge comprises first and second fluidic interfaces (14, 15) which are sockets and the cartridge receiving structure (4) comprises first and second fluidic interfaces (12, 13) which are pens, wherein the first and second fluidic interfaces which are sockets (14, 15) have a depth that is approximately the same as or shorter than a length of the guide track, wherein the central axis of each socket is parallel to said straight line, wherein establishing the fluid connection comprises inserting the pens (12, 13) into the respective sockets (14, 15).
6. The method of claim 5, wherein the cartridge receiving structure (4) comprises a first fluidic interface (12) that is a conically shaped pen, the cartridge (3) comprising a first fluidic interface that is a socket (14), the socket comprising a seal ring (37) having an inner diameter arranged to stretch at least approximately 0,3 millimeters, the method comprising enclosing the pen (12) along its conical shape at insertion.
7. The method of one of claims 1 to 6, wherein the latch track (28) comprises a locking track (28A) and an unlocking track (28B), wherein guiding the latch (27) comprises moving the latch (27) with respect to the latch stop (30) along the locking track (28A) into a locked engagement position at insertion, and along the unlocking track (28B), different from the locking track (28A), into an unlocked position at ejection.
8. The method of one of claims 1 to 7, wherein the electrical circuit (19) is sunken with respect to the cartridge front face (33), so that electrical contact with the electrical connector circuit (18) of the cartridge receiving structure (4) is made after the other interfaces are connected.
9. The method of claim 8, wherein the electrical circuit (19) comprises electrodes (38) that extend in one plane that is approximately perpendicular to the front face of the cartridge (3), and the electrodes (38) extend along a line (PP) that is approximately parallel to the front face (33), the method comprising establishing a sideways connection with a corresponding

connector circuit (18).

10. The method according to any preceding claim, wherein the electrical circuit (10, 19) is to establish sideways (X, B) connection with the corresponding connector circuit (18) within an outer circumference of the cartridge (3).

10 Patentansprüche

1. Verfahren zum Verbinden einer Fluidkartusche (3) mit einer Fluidkartuschen-Aufnahmestruktur (4), wobei die Fluidkartusche (3) eine erste Fluidschnittstelle (14), eine zweite Fluidschnittstelle (15) und eine elektrische Schnittstelle (10, 19) umfasst, wobei diese Schnittstellen in einer Vorderseite (33) angeordnet sind, und die Fluidkartuschen-Aufnahmestruktur (4), die entsprechende erste (12) und zweite (13) Fluidschnittstellen und eine elektrische Anschlussschaltung (18) umfasst, wobei das Verfahren folgende Schritte umfasst:
 - Einsetzen der Fluidkartusche (3) entlang einer geraden Linie (Y) in Bezug auf die Fluidkartuschen-Aufnahmestruktur (4) durch Führen der Fluidkartusche (3) mittels einer Führungsschiene (21), die auf einer Unterseite der Fluidkartusche (3) angeordnet ist und sich parallel zur geraden Linie erstreckt, um eine Fluidverbindung zwischen den ersten Fluidschnittstellen (12, 14), eine Fluidverbindung zwischen den zweiten Fluidschnittstellen (13, 15) sowie eine elektrische Verbindung zwischen der elektrischen Schnittstelle (10, 19) und der elektrischen Anschlussschaltung (18) herzustellen, und Führen, durch die Bewegung entlang der geraden Linie, einer Verriegelung (27) der Kartuschen-Aufnahmestruktur (4) in eine verriegelte Position zum Aufrechterhalten der Fluidverbindung mittels eines Verriegelungsanschlages (30) und einer Verriegelungsschiene (28), die auf der Unterseite der Fluidkartusche (3) angeordnet sind, um die Verriegelung (27) der Kartuschen-Aufnahmestruktur (4) zu führen und zu halten.
2. Verfahren nach Anspruch 1, das folgende Schritte umfasst:
 - Zusammendrücken einer Auswurffeder (31) beim Einsetzen der Fluidkartusche (3), Aufrechterhalten des zusammengedrückten Zustands der Auswurffeder (31), wenn die Verriegelung (27) verriegelt ist, und Auswerfen der Fluidkartusche (3) durch Dekompression der Auswurffeder (31) durch Entriegeln der Verriegelung (27).

3. Verfahren nach Anspruch 2, wobei die Fluidkartusche (3) eine erste Fluidschnittstelle (14), die eine erste Buchse ist, sowie eine zweite Fluidschnittstelle (15) umfasst, die eine zweite Buchse ist, wobei eine ringförmige Auswurf-Ausrichtungsschnittstelle (36) um die zweite Buchse (15) herum angeordnet ist, wobei der Innenumfang eines vorderen Endes (44) der Auswurffeder (31) durch die ringförmige Auswurf-Ausrichtungsschnittstelle (36) in Eingriff genommen wird, um die Auswurffeder (31) auszurichten und in Position zu halten, wenn die Fluidkartusche (3) in Eingriff genommen wird. 5
4. Verfahren nach einem der Ansprüche 1 bis 3, wobei die Führungsschiene (21) einen T-förmigen Ausschnitt zum Führen einer entsprechenden T-Schiene der Kartuschen-Aufnahmestruktur (4) aufweist. 10
5. Verfahren nach Anspruch 1 oder 2, wobei die Kartusche erste und zweite Fluidschnittstellen (14, 15) umfasst, die Buchsen sind, und die Kartuschen-Aufnahmestruktur (4) erste und zweite Fluidschnittstellen (12, 13) umfasst, die Stifte sind, wobei die ersten und zweiten Fluidschnittstellen, die Buchsen (14, 15) sind, eine Tiefe aufweisen, die etwa gleich groß wie oder kürzer als eine Länge der Führungsschiene ist, wobei die Mittelachse jeder Buchse parallel zu der geraden Linie ist, wobei das Herstellen der Fluidverbindung das Einsetzen der Stifte (12, 13) in die jeweiligen Buchsen (14, 15) umfasst. 20
6. Verfahren nach Anspruch 5, wobei die Kartuschen-Aufnahmestruktur (4) eine erste Fluidschnittstelle (12) umfasst, die ein konisch geformter Stift ist, wobei die Kartusche (3) eine erste Fluidschnittstelle umfasst, die eine Buchse (14) ist, wobei die Buchse einen Dichtungsring (37) mit einem Innendurchmesser aufweist, der so angeordnet ist, dass er sich mindestens etwa 0,3 Millimeter dehnt, wobei das Verfahren das Umschließen des Stiftes (12) entlang seiner konischen Form beim Einsetzen umfasst. 25
7. Verfahren nach einem der Ansprüche 1 bis 6, wobei die Verriegelungsschiene (28) eine Verriegelungsschiene (28A) und eine Entriegelungsschiene (28B) umfasst, wobei das Führen der Verriegelung (27) das Bewegen der Verriegelung (27) in Bezug auf den Verriegelungsanschlag (30) entlang der Verriegelungsschiene (28A) in eine verriegelte Ineingriffnahmeposition beim Einführen und entlang der Entriegelungsschiene (28B), die sich von der Verriegelungsschiene (28A) unterscheidet, in eine entriegelte Position beim Auswerfen umfasst. 30
8. Verfahren nach einem der Ansprüche 1 bis 7, wobei die elektrische Schaltung (19) in Bezug auf die Kar-

tuschenvorderseite (33) versenkt wird, so dass ein elektrischer Kontakt mit der elektrischen Anschlussschaltung (18) der Kartuschen-Aufnahmestruktur (4) hergestellt wird, sobald die anderen Schnittstellen verbunden sind. 35

9. Verfahren nach Anspruch 8, wobei die elektrische Schaltung (19) Elektroden (38) umfasst, die sich in einer Ebene erstrecken, die etwa senkrecht zur Vorderseite der Kartusche (3) verläuft, und die Elektroden (38) sich entlang einer Linie (PP) erstrecken, die etwa parallel zur Vorderseite (33) verläuft, wobei das Verfahren das Herstellen einer seitlichen Verbindung mit einer entsprechenden Anschlussschaltung (18) umfasst. 40
10. Verfahren nach einem vorhergehenden Anspruch, wobei die elektrische Schaltung (10, 19) eine seitliche (X, B) Verbindung mit der entsprechenden Anschlussschaltung (18) innerhalb eines äußeren Umfangs der Kartusche (3) herstellen soll. 45

Revendications

1. Procédé de liaison d'une cartouche de fluide (3) à une structure de réception de cartouche de fluide (4), la cartouche de fluide (3) comprenant une première interface fluide (14), une seconde interface fluide (15) et une interface électrique (10, 19), ces interfaces étant disposées sur une face avant (33), et la structure de réception de cartouche de fluide (4) comprenant des première (12) et seconde (13) interfaces fluidiques correspondantes et un circuit de connexion électrique (18), le procédé comprenant :

l'insertion de la cartouche de fluide (3) le long d'une ligne droite (Y) par rapport à la structure de réception de cartouche de fluide (4) en guidant la cartouche de fluide (3) à l'aide d'un rail de guidage (21) disposé sur une face inférieure de la cartouche de fluide (3) et s'étendant parallèlement à la ligne droite, de façon à établir une liaison fluide entre les premières interfaces fluidiques (12, 14), une liaison fluide entre les secondes interfaces fluidiques (13, 15) et une connexion électrique entre l'interface électrique (10, 19) et le circuit de connexion électrique (18), et

le guidage d'un verrou (27) de la structure de réception de cartouche (4), à l'aide dudit déplacement le long de la ligne droite, dans une position verrouillée, afin de maintenir la liaison fluide en utilisant une butée de verrouillage (30) et un rail de verrouillage (28) qui sont disposés sur la face inférieure de la cartouche de fluide (3), pour guider et pour retenir le verrou (27) de

- la structure de réception de cartouche (4).
2. Procédé selon la revendication 1, comprenant :
- la compression d'un ressort éjecteur (31) lors de l'insertion de la cartouche de fluide (3), avec maintien du ressort éjecteur (31) dans l'état comprimé lorsque le verrou (27) est verrouillé, et l'éjection de la cartouche de fluide (3) par décompression du ressort éjecteur (31), par déblocage du verrou (27).
3. Procédé selon la revendication 2, dans lequel la cartouche de fluide (3) comprend une première interface fluïdique (14) qui est une première cavité, et une seconde interface fluïdique (15) qui est une seconde cavité, une interface d'alignement d'éjecteur de forme annulaire (36) étant disposée autour de la seconde cavité (15), la circonférence interne d'une extrémité avant (44) du ressort éjecteur (31) venant en prise avec l'interface d'alignement d'éjecteur de forme annulaire (36), de façon à aligner et à maintenir le ressort éjecteur (31) en position lors de la prise avec la cartouche de fluide (3).
4. Procédé selon l'une des revendications 1 à 3, dans lequel le rail de guidage (21) comprend une découpe en forme de T permettant de guider un rail en T correspondant de la structure de réception de cartouche (4).
5. Procédé selon la revendication 1 ou 2, dans lequel la cartouche comprend des premières et secondes interfaces fluïdiques (14, 15) qui sont des cavités, et où la structure de réception de cartouche (4) comprend des première et seconde interfaces fluïdiques (12, 13) qui sont des styles, les premières et secondes interfaces fluïdiques qui sont des cavités (14, 15) ayant une profondeur approximativement inférieure ou égale à la longueur du rail de guidage, l'axe central de chaque cavité étant parallèle à ladite ligne droite, l'établissement de la liaison fluïdique consistant à insérer les styles (12, 13) dans les cavités respectives (14, 15).
6. Procédé selon la revendication 5, dans lequel la structure de réception de cartouche (4) comprend une première interface fluïdique (12) qui est un style de forme conique, la cartouche (3) comprenant une première interface fluïdique qui est une cavité (14), la cavité comprenant une bague d'étanchéité (37) ayant un diamètre interne permettant une extension d'au moins environ 0,3 mm, le procédé consistant à enfermer le style (12) le long de sa forme conique lors de l'insertion.
7. Procédé selon l'une des revendications 1 à 6, dans laquelle le rail de verrouillage (28) comprend un rail de blocage (28A) et un rail de déblocage (28B), le guidage du verrou (27) consistant à déplacer le verrou (27) par rapport à la butée de verrouillage (30) le long d'un rail de blocage (28A) jusqu'à une position d'enclenchement bloquée lors de l'insertion, et le long d'un rail de déblocage (28B), différent du rail de blocage (28A), dans une position déblocée lors de l'éjection.
8. Procédé selon l'une des revendications 1 à 7, dans lequel le circuit électrique (19) est enfoncé par rapport à la face avant de la cartouche (33), de sorte que le contact électrique avec le circuit de connexion électrique (18) de la structure de réception de cartouche (4) soit établi après la connexion des autres interfaces.
9. Procédé selon la revendication 8, dans lequel le circuit électrique (19) comprend des électrodes (38) s'étendant dans un plan approximativement perpendiculaire à la face avant de la cartouche (3), et où les électrodes (38) s'étendent le long d'une ligne (PP) approximativement parallèle à la face avant (33), le procédé consistant à établir une connexion latérale avec un circuit de connexion correspondant (18).
10. Procédé selon l'une des revendications précédentes, dans lequel le circuit électrique (10, 19) doit établir une connexion latérale (X, B) avec le circuit de connexion correspondant (18) dans une circonférence externe de la cartouche (3).

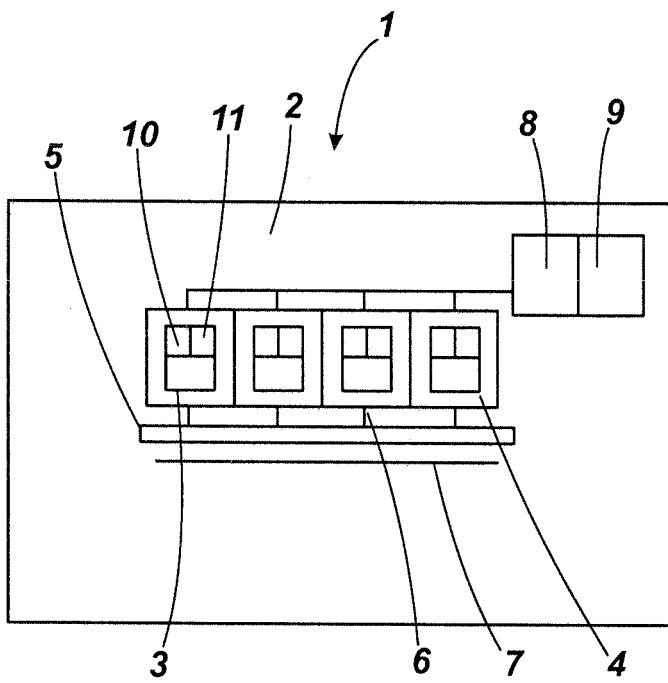

Fig. 1

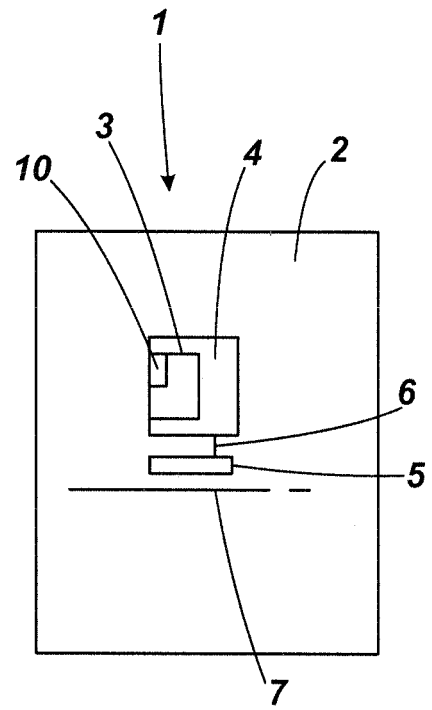
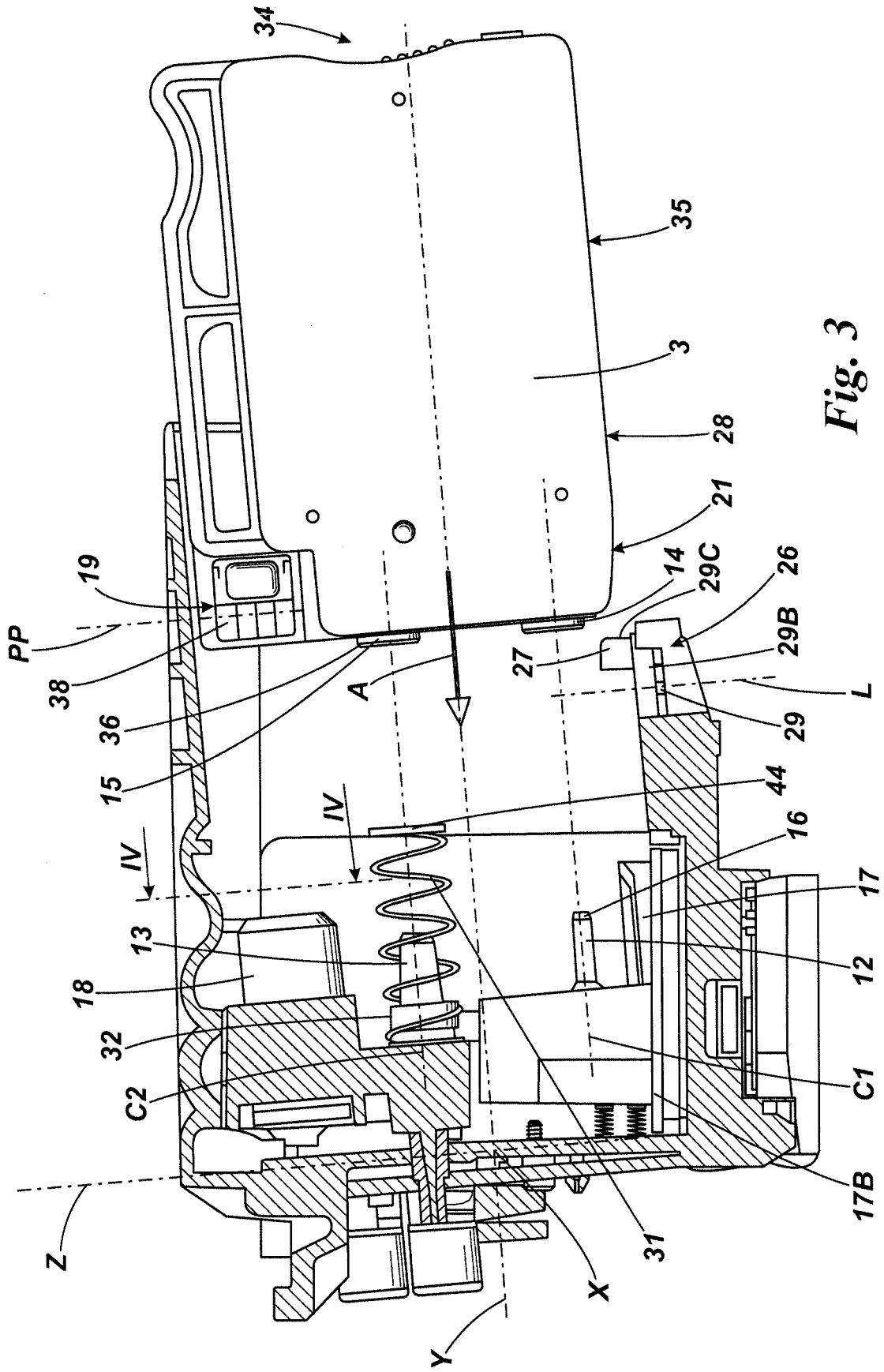

Fig. 2



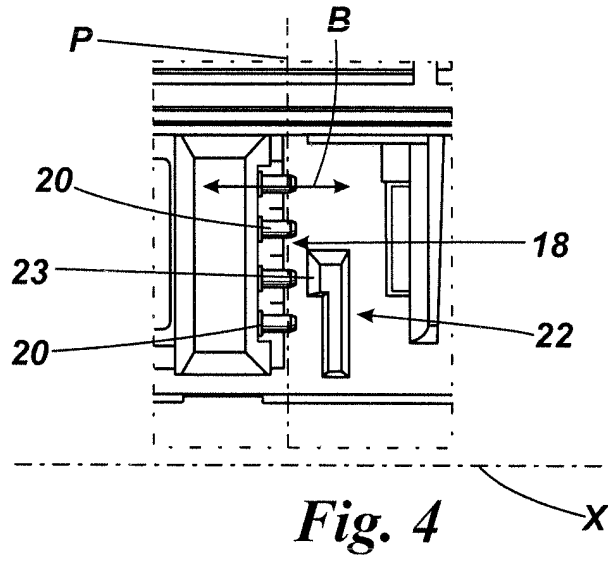

Fig. 4

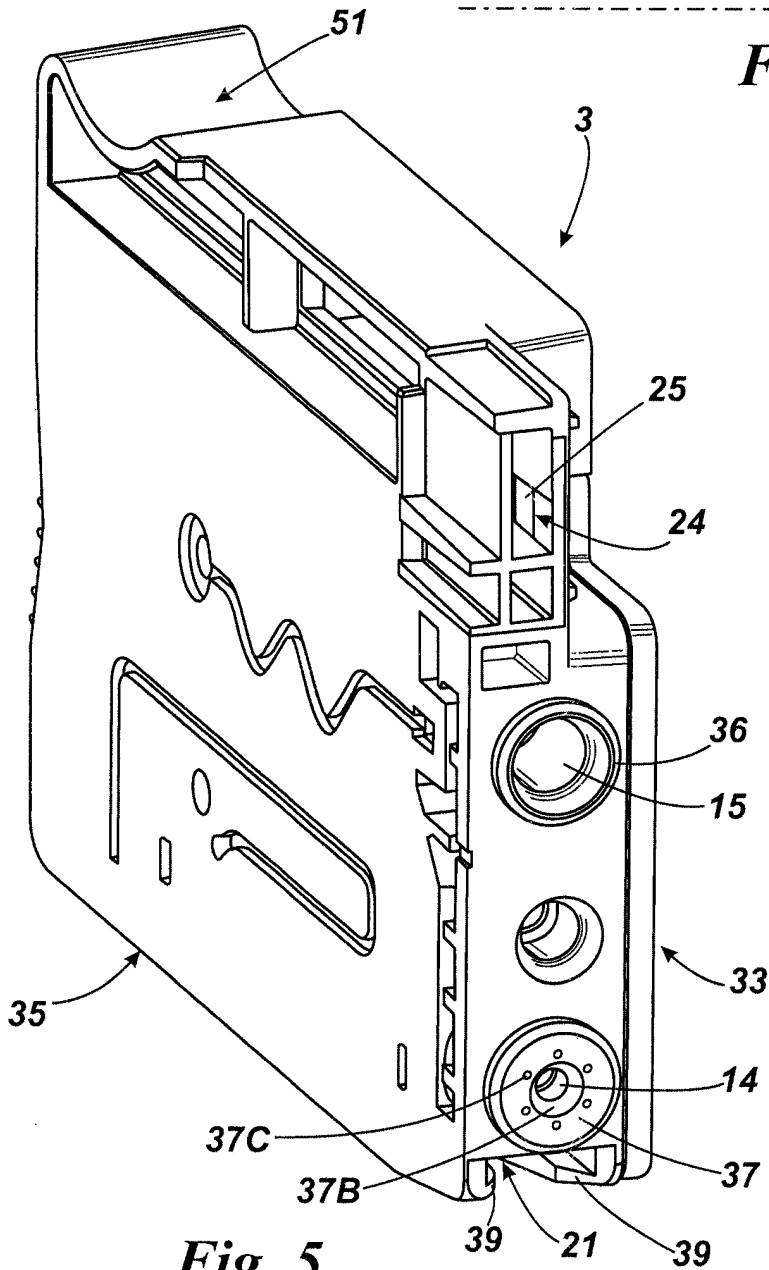

Fig. 5

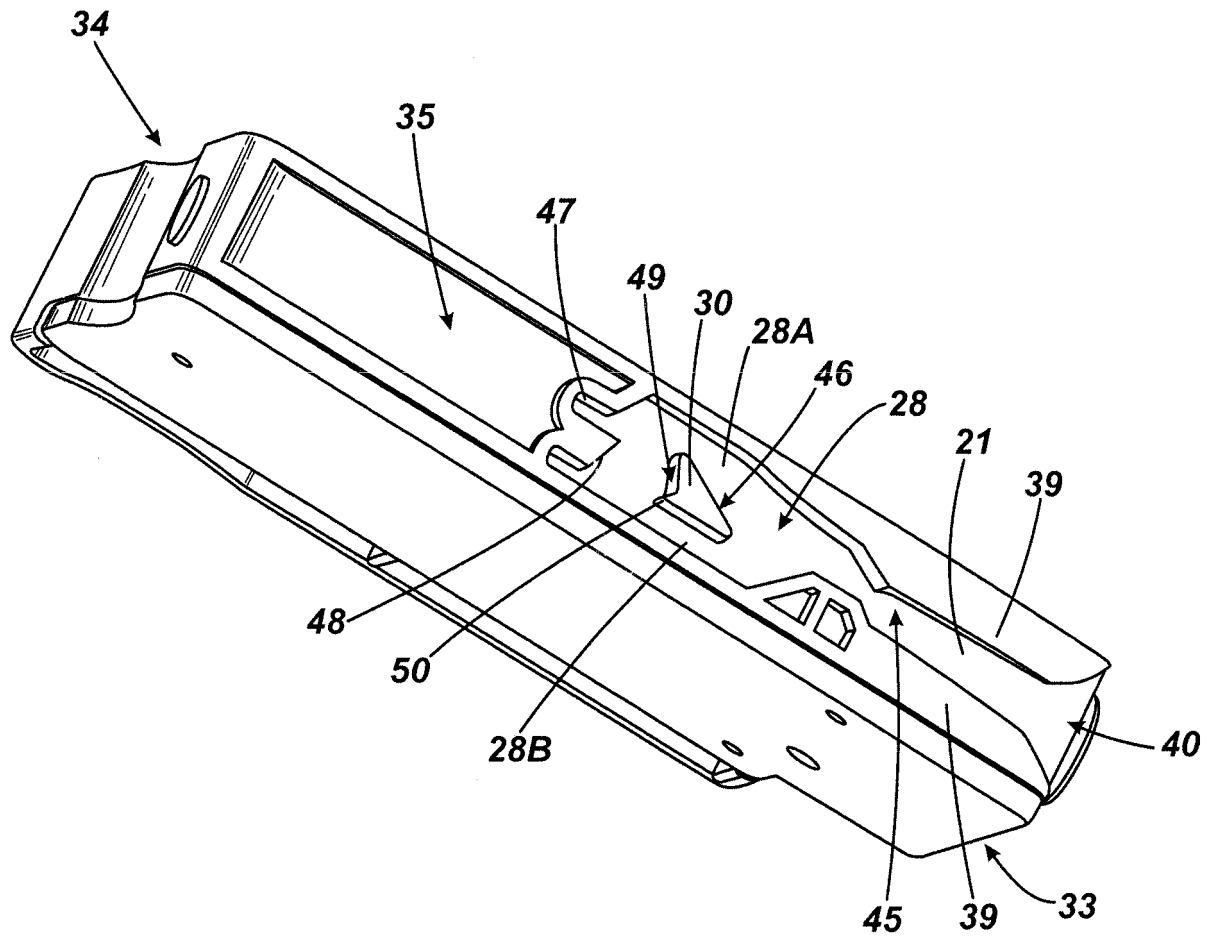

Fig. 6

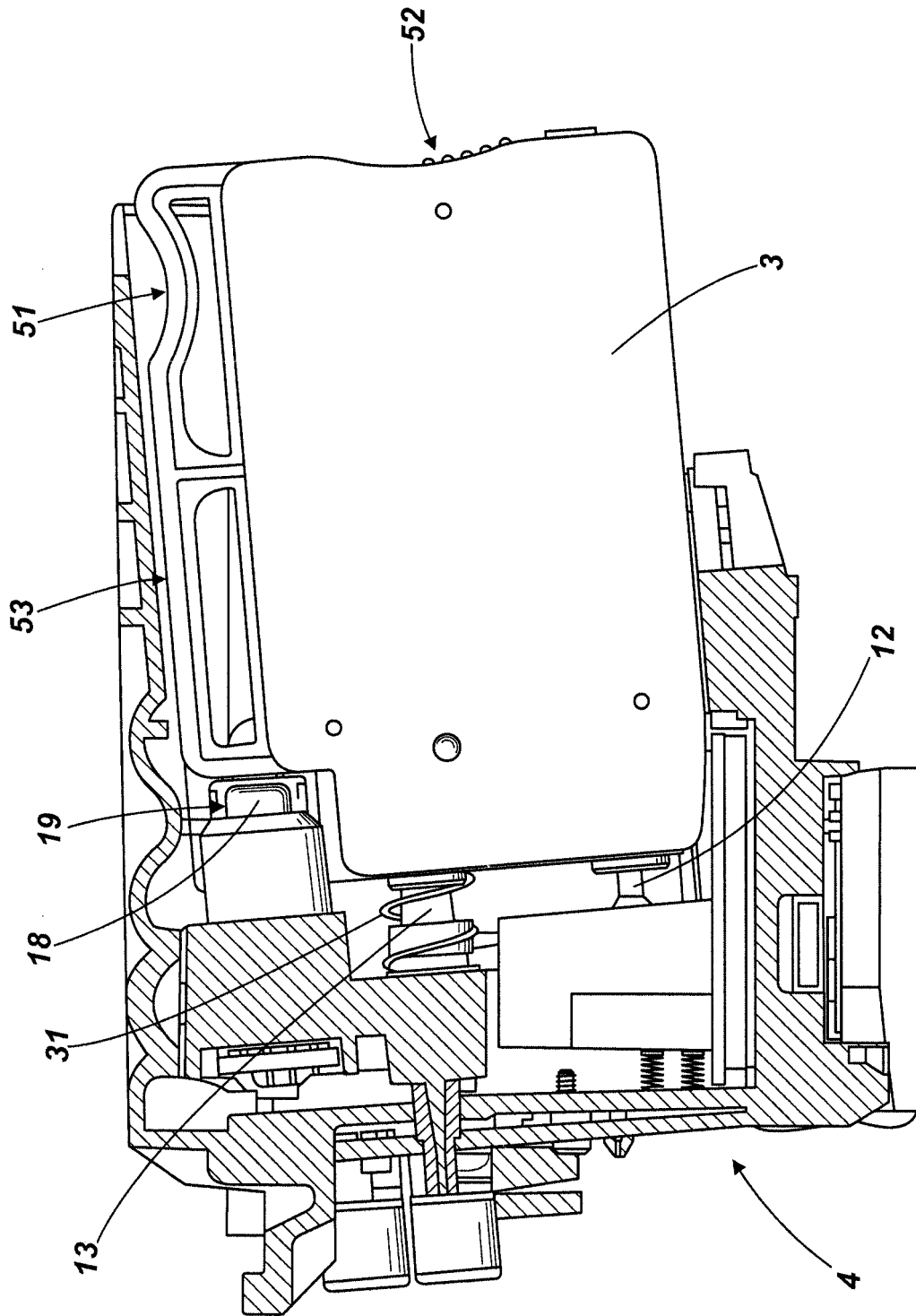

Fig. 7

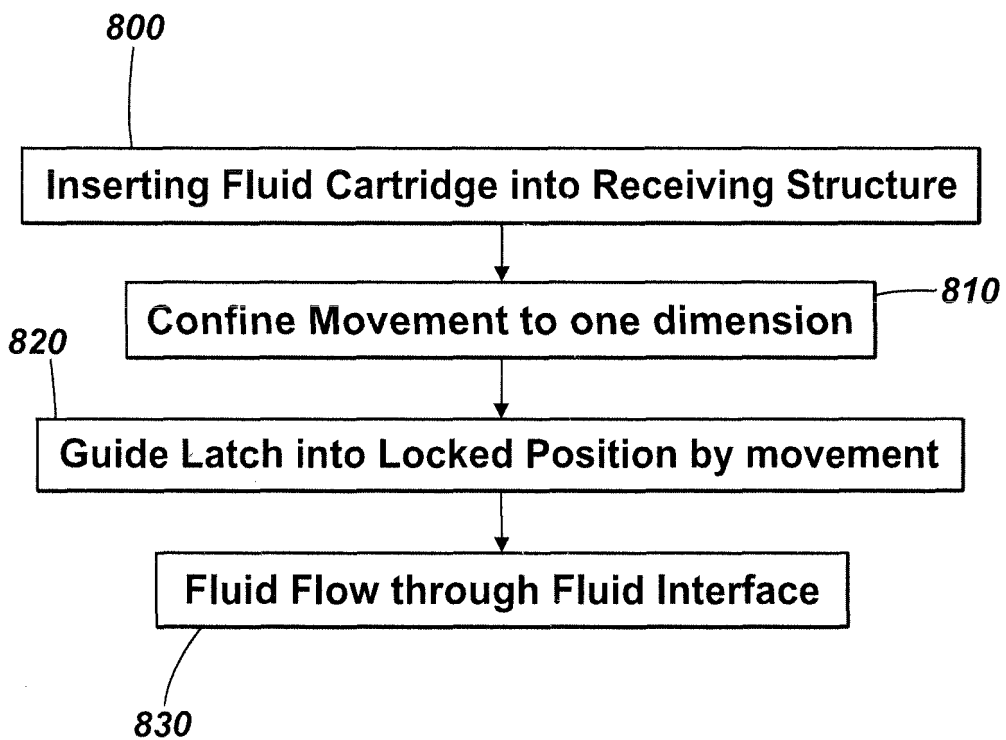
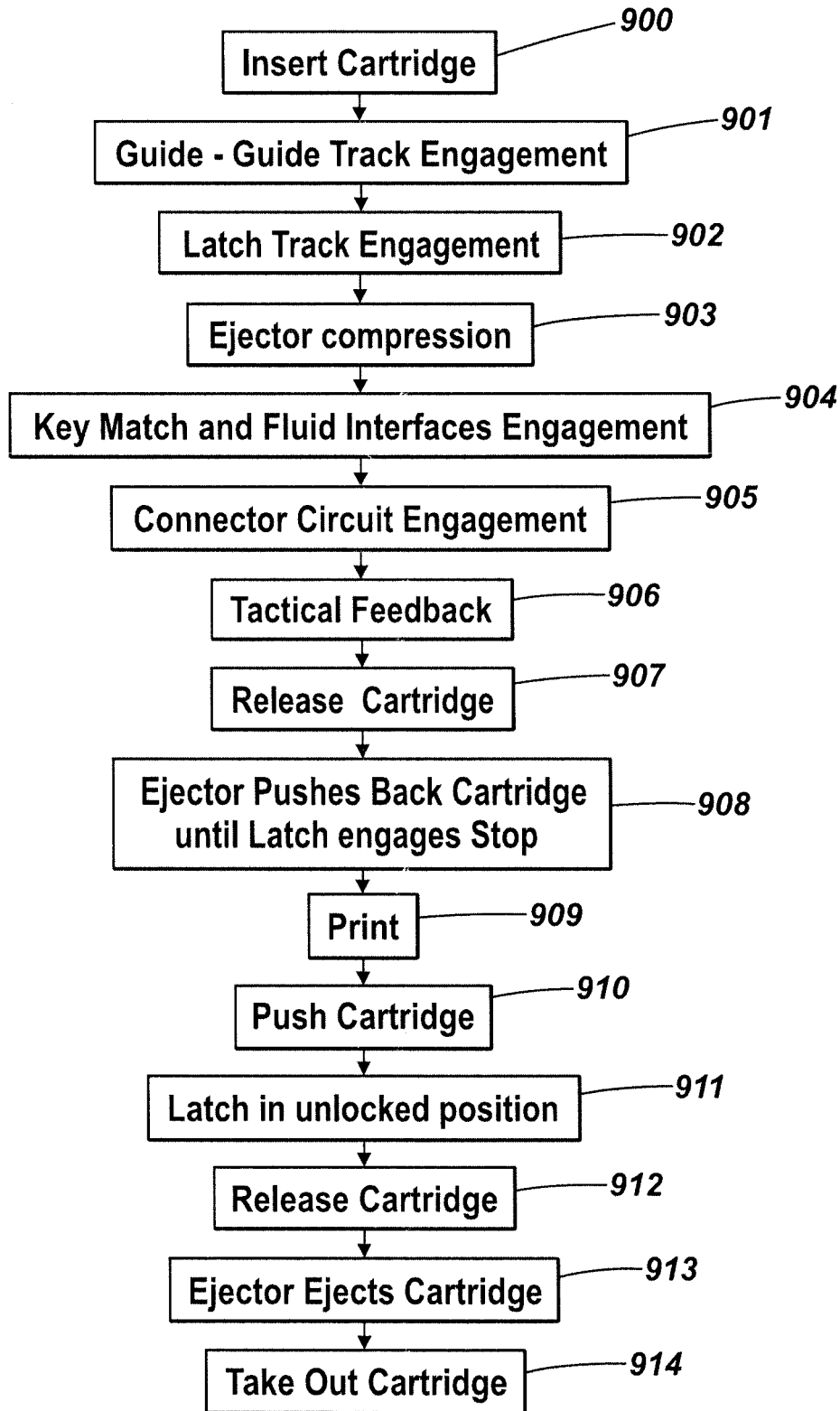

Fig. 8

*Fig. 9*

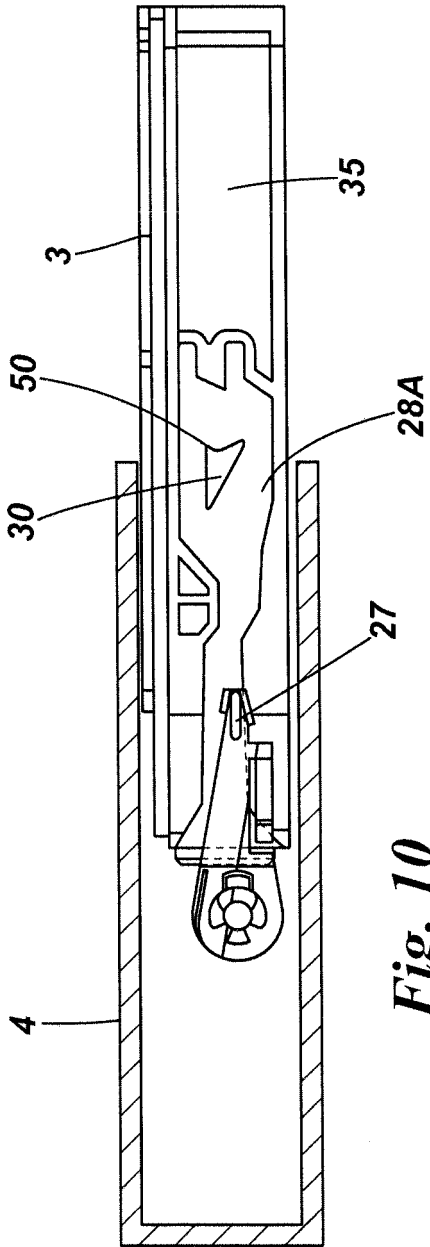

Fig. 10

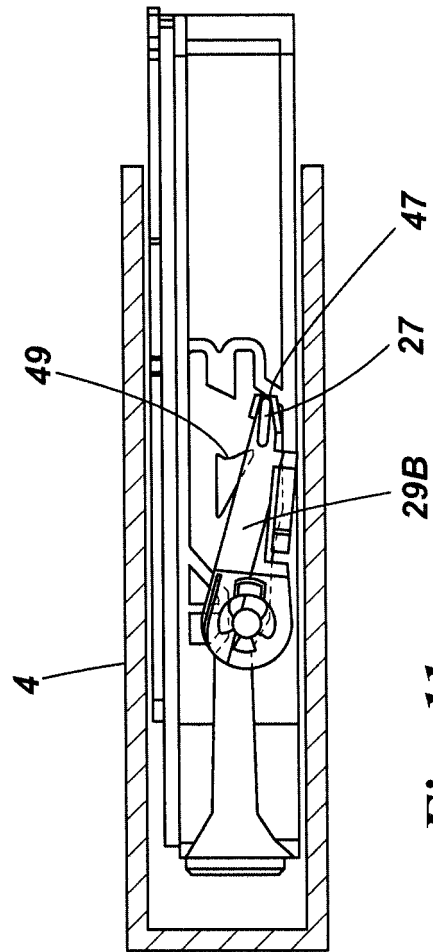

Fig. 11

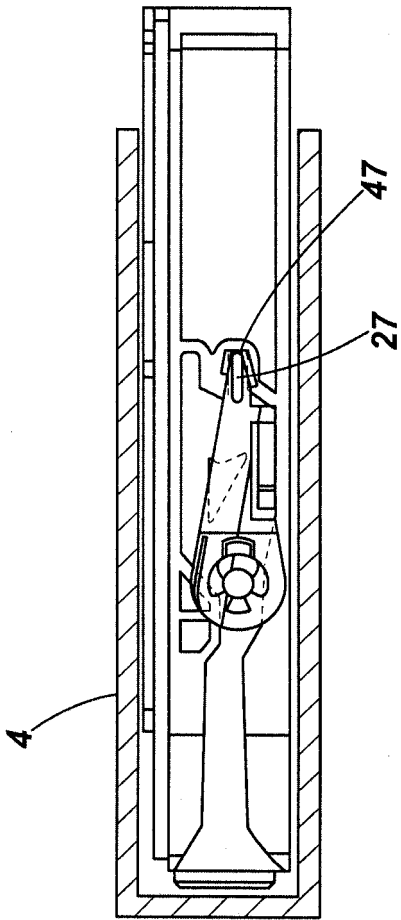

Fig. 12

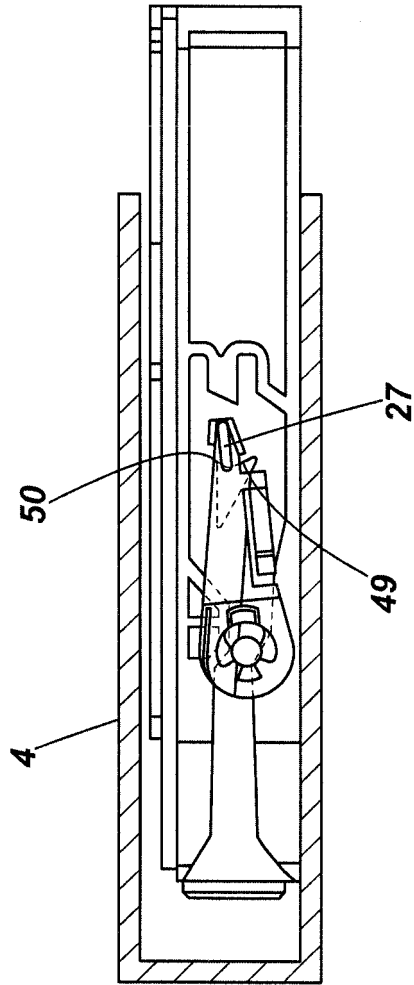

Fig. 13

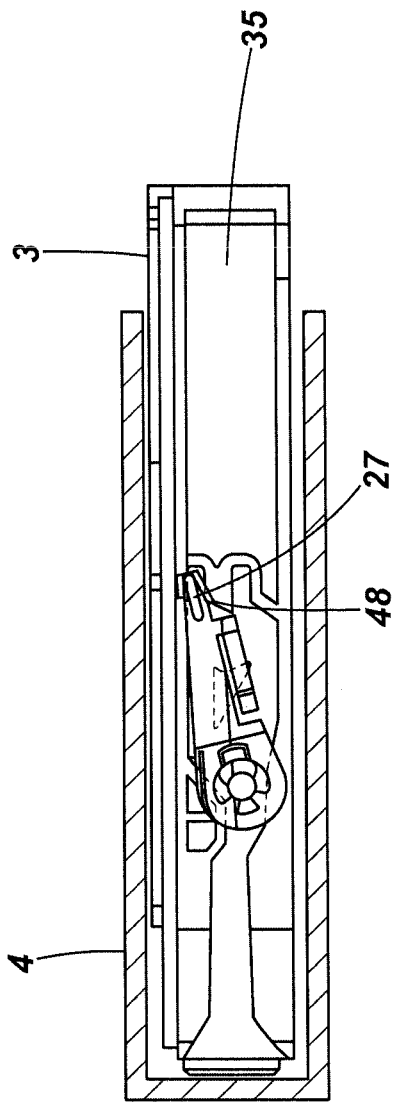

Fig. 14

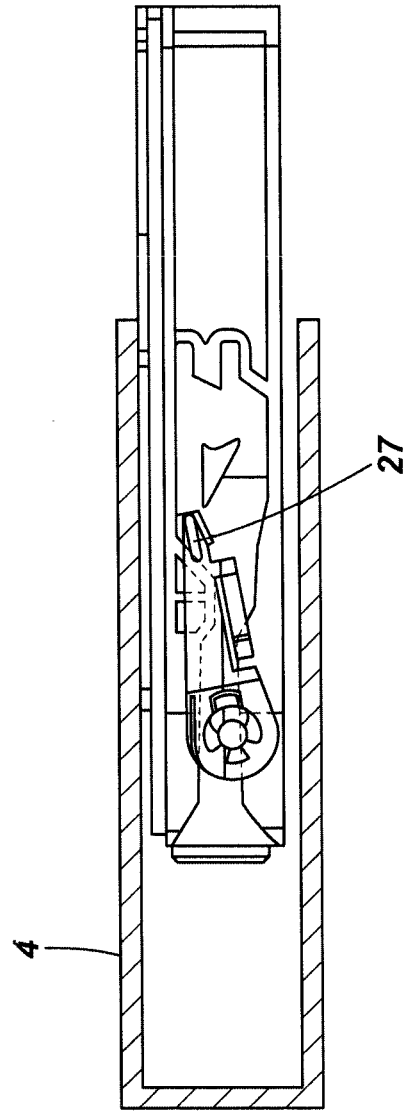

Fig. 15

REFERENCES CITED IN THE DESCRIPTION

This list of references cited by the applicant is for the reader's convenience only. It does not form part of the European patent document. Even though great care has been taken in compiling the references, errors or omissions cannot be excluded and the EPO disclaims all liability in this regard.

Patent documents cited in the description

- EP 1348562 A2 [0004]
- EP 1122078 A2 [0004]
- US 20070013753 A1 [0004]
- GB 2316657 A [0004]
- EP 1815994 A2 [0004]