

(19)



(11)

EP 3 067 458 B1

(12)

EUROPEAN PATENT SPECIFICATION

(45) Date of publication and mention of the grant of the patent:
05.09.2018 Bulletin 2018/36

(51) Int Cl.:
D06F 39/02 (2006.01)

(21) Application number: **16152070.5**

(22) Date of filing: **20.01.2016**

(54) **DETERGENT BOX ASSEMBLY FOR WASHING MACHINE AND WASHING MACHINE**
 WASCHMITTELSCHALENANORDNUNG FÜR WASCHMASCHINE UND WASCHMASCHINE
 ENSEMBLE BOÎTE DE DÉTERGENT POUR MACHINE À LAVER ET MACHINE À LAVER

(84) Designated Contracting States:
AL AT BE BG CH CY CZ DE DK EE ES FI FR GB GR HR HU IE IS IT LI LT LU LV MC MK MT NL NO PL PT RO RS SE SI SK SM TR

(30) Priority: **13.03.2015 CN 201510112716**
13.03.2015 CN 201520145097 U
12.08.2015 CN 201510494878
12.08.2015 CN 201520607469 U

(43) Date of publication of application:
14.09.2016 Bulletin 2016/37

(73) Proprietor: **Wuxi Little Swan Co., Ltd.**
New District
Wuxi
Jiangsu 214028 (CN)

(72) Inventors:
 • **PARK, Chanwi**
Wuxi Jiangsu 214028 (CN)

- **LIU, Chunyi**
Wuxi Jiangsu 214028 (CN)
- **HU, Wei**
Wuxi Jiangsu 214028 (CN)
- **XIAO, Ze**
Wuxi Jiangsu 214028 (CN)
- **XIAO, Junxing**
Wuxi Jiangsu 214028 (CN)
- **YE, Dexin**
Wuxi Jiangsu 214028 (CN)
- **XU, Pengcheng**
Wuxi Jiangsu 214028 (CN)

(74) Representative: **Romano, Giuseppe et al**
Società Italiana Brevetti S.p.A
Piazza di Pietra, 39
00186 Roma (IT)

(56) References cited:
EP-A1- 0 465 800 EP-A2- 1 403 415
EP-A2- 1 593 767 CN-U- 203 729 113
US-A1- 2009 261 697 US-A1- 2009 322 195

EP 3 067 458 B1

Note: Within nine months of the publication of the mention of the grant of the European patent in the European Patent Bulletin, any person may give notice to the European Patent Office of opposition to that patent, in accordance with the Implementing Regulations. Notice of opposition shall not be deemed to have been filed until the opposition fee has been paid. (Art. 99(1) European Patent Convention).

Description**FIELD**

[0001] Embodiments of the present invention generally relate to a field of a washing machine, and more particularly, to a detergent box assembly for a washing machine and a washing machine.

BACKGROUND

[0002] In the related art, a distributor box for storing washing powder in a washing machine usually is opened and closed by manual drawing, and thus a hand clasp groove convenient to be held by a user needs to be provided in the distributor box so as to facilitate the drawing of the distributor box. However, the hand clasp groove may not only affect an overall appearance of the washing machine, but also tend to accumulate dust therein. Furthermore, since opening and closing of the distributor are performed by manual operations, a hand feeling and an experience feeling of the user are poor and a usage comfort thereof is not high. Moreover, it needs to draw the distributor box out manually to put the washing powder into the distributor box before washing clothes each time, thus resulting in great labor intensity.

[0003] US2009261697 A1 discloses an appliance drawer construction, which allows, upon the press of a button, the extension of the drawer from a housing. At the same time, inadvertent unintended opening caused, e.g., by a person's body brushing past or up against the appliance, may be avoided. In another aspect, the invention provides a simple and effective latch release linkage which is particularly well suited to a drawer, like a laundry washer additives dispenser drawer, that requires an offset of the latch from the operation push-button, due to the placement of an additive storage compartment portion of the drawer directly behind the front console of the drawer, and the space constraints within the housing that receives the drawer. US 20090322195 A1 discloses an additive dispenser drawer including roller assemblies located on opposite sides near a rear portion of the dispenser drawer. Each roller assembly moves within a guide rail attached to a side of a housing. Bearing fixtures are attached to the housing near the front and act upon surfaces of the dispenser drawer. EP1403415 A2 discloses a device for automatically extracting from a seat (4) a drawer (3) for dispensing detergent and/or other process fluids of an electric household appliance; the device including a release device (10), elastic means (11) for pushing the drawer from the seat into an extracted position, and decelerating means (12) for opposing the movement of the drawer; wherein the elastic means act on a rotary-to-linear motion conversion device (14) located between the drawer (3) and a fixed member of the seat (4) to produce a linear movement of the seat into the extracted position upon release of the elastic means (11); and wherein the decelerating means act on a rotary

member (15) of the rotary-to-linear motion conversion device (14). EP0465800 A1 discloses a detergent dispenser compartment (4) which is designed as a drawer and is movable by a motor (11) by means of a flexible adjusting rod (13). Many advantages can thereby be combined: installation under difficult conditions of space; functional reliability despite the simple guidance of the drawer with the danger of tilting; manual operability; simple uncoupling and removal of the drawer for cleaning purposes; drive insensitive to water splashes.

SUMMARY

[0004] Embodiments of the present invention seek to solve at least one of the problems existing in the related art to at least some extent. Accordingly, embodiments of the present invention provide a detergent box assembly for a washing machine, which can be opened and closed without manual drawing.

[0005] Embodiments of the present invention further provide a washing machine including the above detergent box assembly. In accordance with the present invention, there is provided a detergent box assembly for a washing machine, including: a detergent box provided with an upper cover subassembly; a distributor box having a front plate, a rear plate and a receiving chamber provided therebetween, said receiving chamber configured to store a laundry treat agent, the distributor box being movably disposed within the detergent box and adapted to move between an open position and a closed position, a key-press being provided in the front plate; and a driving subassembly configured to drive the distributor box to move from the closed position to the open position when the key-press is pressed.

[0006] The driving subassembly includes a gear assembly, a rack, and a tension spring. The gear assembly is disposed on the upper cover subassembly of the detergent box. The rack is provided on the upper cover subassembly of the detergent box and adapted to be engaged with the gear assembly, the rack having a free end adjacent to the front plate of the distributor box and a snap-fit end away from the front plate of the distributor box and opposite to the free end along a length direction thereof, the snap-fit end of the rack being configured to be engageable with the rear plate of the distributor box and formed with a downwardly-extending leg engageable with the rear plate of the distributor box. The tension spring is disposed along the length direction of the rack and has a first end and a second end opposite to the first end, the first end being adjacent to the front plate of the distributor box and mounted on the upper cover subassembly of the detergent box, the second end being coupled to the rack and adjacent to the snap-fit end of the rack.

[0007] The detergent box assembly further includes a lock catch associated with the key-press and provided at the distributor box, the lock catch configured to be lockably engaged by the washing machine such that when

the key-press is pressed, the lock catch is unlocked and disengaged by the washing machine, the rack is driven by the tension spring to enable the distributor box to be moved from the closed position to the open position, and the upper cover subassembly of the detergent box includes a first cover part and a second cover part assembled with each other, the second cover part is provided with a mounting slot and the rack is mounted within the mounting slot of the second cover part.

[0008] With the detergent box assembly for the washing machine according to embodiments of the present invention, regardless of an automatically inputting washing machine or a non-automatically inputting washing machine, by using a mechanical control in which the driving subassembly is fitted with the key-press, the distributor box can be ejected out automatically or semi-automatically without a manual drawing by a user, thus improving a usage comfort. Furthermore, the mechanical control reduces a cost effectively, brings convenient operations and improves the reliability.

[0009] Optionally, the second end of the tension spring is fixed to the snap-fit end of the rack.

[0010] Optionally, the gear assembly includes at least one damping gear disposed adjacent to a side edge of the mounting slot.

[0011] Specifically, the gear assembly comprises a plurality of damping gears disposed adjacent to a same side of the mounting slot.

[0012] Optionally, the damping gear defines thereof a horizontally-arranged rotation axis.

[0013] In some embodiments, the detergent box assembly for the washing machine further includes a lock catch associated with the key-press and provided at the distributor box, the lock catch being lockably engaged on the upper cover subassembly of the detergent box so as to keep the lock catch located at a lock-catch manner on the washing machine.

[0014] Preferably, the upper cover subassembly of the detergent box includes a first cover part and a second cover part assembled with each other, the lock catch is lockably engaged on the second cover part of the detergent box to keep the lock catch in the lock-catch manner.

[0015] Embodiments of a second aspect of the present invention provide a washing machine comprising the aforementioned detergent box assembly, wherein the detergent box is included in a machine housing assembly of the washing machine.

[0016] Additional aspects and advantages of embodiments of present invention will be given in part in the following descriptions, become apparent in part from the following descriptions, or be learned from the practice of the embodiments of the present invention.

BRIEF DESCRIPTION OF THE DRAWINGS

[0017] These and other aspects and advantages of embodiments of the present invention will become apparent and more readily appreciated from the following

descriptions made with reference to the accompanying drawings, in which:

Fig. 1 is a schematic view showing a distributor box according to an embodiment of the present invention;

Fig. 2 is an exploded view showing a detergent box for a washing machine according to an embodiment of the present invention;

Fig. 3 is a schematic view showing a distributor box in a closed position shown in Fig. 2;

Fig. 4 is a partially schematic view showing a detergent box assembly for a washing machine shown in Fig. 3, in which a first cover part is not shown;

Fig. 5 is a top view showing a detergent box assembly for a washing machine shown in Fig. 4;

Fig. 6 is a schematic view showing a distributor box in an open position shown in Fig. 2;

Fig. 7 is a partially schematic view showing a detergent box assembly for a washing machine shown in Fig. 6, in which a first cover part is not shown;

Fig. 8 is a top view showing a detergent box assembly for a washing machine shown in Fig. 7.

Reference numerals:

[0018]

100: detergent box assembly;

1: detergent box; 11: first cover part; 12: second cover part; 13: base seat;
2: distributor box; 21: main body of distributor box; 211: receiving chamber;
211a: first sub receiving chamber; 211b: second sub receiving chamber 211b; 211c: third sub receiving chamber;

22: front plate; 221: key-press; 222: lock catch;

2221: first guiding surface; 2222: second guiding surface;

2231: first compression spring; 2232: second compression spring;

3: tension spring; 31: first end; 32: second end;

4: gear assembly; 41: damping gear;

5: rack; 51: free end; 52: snap-fit end; 53: leg;

54: position limiting part.

DETAILED DESCRIPTION

[0019] Reference will be made in detail to embodiments of the present disclosure. Embodiments of the present disclosure will be shown in drawings, in which the same or similar elements and the elements having same or similar functions are denoted by like reference numerals throughout the descriptions. The embodiments

described herein according to drawings are explanatory and illustrative, not construed to limit the present disclosure.

[0020] The following description provides a plurality of embodiments or examples configured to achieve different structures of the present disclosure. In order to simplify the publication of the present disclosure, components and dispositions of the particular embodiment are described in the following, which are only explanatory and not construed to limit the present disclosure. In addition, the present disclosure may repeat the reference number and/or letter in different embodiments for the purpose of simplicity and clarity, and the repeat does not indicate the relationship of the plurality of embodiments and/or dispositions. Furthermore, examples of different processes and materials are provided in the present disclosure. However, it would be appreciated by those skilled in the art that other processes and/or materials may be also applied.

[0021] A detergent box assembly 100 for a washing machine according to embodiments of a first aspect of the present invention will be described in the following with reference to Figs. 1 to 8. The washing machine may be a front loading washing machine or a top loading washing machine. In following descriptions of the present invention, illustrations are performed by taking the roller washing machine as an example.

[0022] As shown in Fig. 2, the detergent box assembly 100 for the washing machine according to the embodiments of the first aspect of the present invention includes a detergent box 1, a distributor box 2 and a driving sub-assembly.

[0023] As shown in Figs. 1 and 2, the distributor box 2 has a front plate 22, a rear plate (not shown) and a receiving chamber 211 provided therebetween, and the receiving chamber 211 is configured to store a laundry treat agent. For example, in an embodiment of the present invention in Fig. 2, the distributor box 2 includes a main body 21 of the distributor box, the front plate 22 and the rear plate. The front plate 22 is fixed at a front end of the main body 21 of the distributor box, and the rear plate is fixed at a rear end of the main body 21 of the distributor box. The receiving chamber 211 whose top end is open is provided in the distributor box 2 and is used to store the laundry treat. Herein, the laundry treat agent may include scrubbing solution and washing powder, and it should be noted that the scrubbing solution should be understood widely and include all liquid solvent for washing clothes, such as laundry detergent and softener, and also, the washing powder should be understood widely and include all solid powder for washing clothes, such as the washing powder and the bleaching powder.

[0024] As shown in Fig. 1, the receiving chamber 211 may include a plurality of sub receiving chambers separated from each other and configured to receive different laundry treat agents, and each sub receiving chamber may have a rear end communicating with a scrubbing space in the washing machine. For example, in an em-

bodiment in Fig. 1, the receiving chamber 211 includes three sub receiving chambers extending in a front and rear direction respectively and separated from each other in a right and left direction, i.e., a first sub receiving chamber 211a, a second sub receiving chamber 211b and a third sub receiving chamber 211c. The first sub receiving chamber 211a is a prewashing bin adapted to store the laundry detergent or the washing power, the second sub receiving chamber 211b is a main washing bin adapted to store the laundry detergent or the washing power, and the third sub receiving chamber 211c is adapted to store the softener. It may be understood that, the number and arrangement of the sub receiving chambers may be modified adaptively according to actual requirements, so as to better satisfy the actual requirements.

[0025] The distributor box 2 is movably disposed within the detergent box 1, i.e., the distributor box 2 is movable with respect to the detergent box 1 and the distributor box 2 is disposed within the detergent box 1 in at least a moment. Specifically, the distributor box 2 is adapted to move between an open position and a closed position, i.e., the distributor box 2 has an open state and a closed state. When the distributor box 2 moves to the open position (as shown in Fig. 6), at least a portion of the distributor box 2 extends out of a front surface of the detergent box 1, and thus the laundry treat agent can be put into the receiving chamber 211 in the distributor box 2 at this time. When the distributor box 2 moves to the closed position (as shown in Fig. 3), preferably, a front surface of the front plate 22 of the distributor box 2 is substantially in flush with the front surface of the detergent box 1, so as to ensure that the washing machine has a neat and beautiful appearance.

[0026] Regardless of an automatically inputting washing machine or a non-automatically inputting washing machine, a user needs to open the distributor box 2 to put the laundry treat agent into the receiving chamber 211. In particular, for the non-automatically inputting washing machine, the user needs to open the distributor box 2 each time when washing clothes. If the user needs to draw the distributor box 2 manually so as to open and close the distributor box 2 each time, labour intensity of the user will be increased naturally and positivity of the user to use the washing machine will be decreased.

[0027] Therefore, in order to open and close the distributor box 2 easily and conveniently, the detergent box assembly 100 according to embodiments of the present invention further includes a driving subassembly and a key-press 221. Every time when the user needs to put the laundry treat agent, it only needs to press the key-press 221, and thus the distributor box 2 can be ejected out automatically or semi-automatically under a driving function of the driving subassembly, so that the user can open the distributor box 2 easily. Thus, the labour intensity of the user is decreased naturally and the positivity of the user to use the washing machine is improved.

[0028] Specifically, the driving subassembly may be disposed in at least one of the detergent box 1 and the

distributor box 2. That is, the driving subassembly may be disposed in the distributor box 2, or the driving subassembly may also be disposed in the detergent box 1, or a portion of the driving subassembly may be disposed in the distributor box 2 and rest of the driving subassembly may be disposed in the detergent box 1. A key-press 221 is provided in the front plate 22, and the driving subassembly is configured to drive the distributor box 2 to move from the closed position to the open position when the key-press 221 is pressed. That is, after the key-press 221 is pressed, the distributor box 2 may be ejected forwards out of the detergent box 1 automatically so as to be opened, so that the receiving chamber 211 is present to the user, which facilitates putting the laundry treatment agent into the receiving chamber 211 by the user, without the manual drawing, and improves the usage comfort of the washing machine. Herein, a configuration of the driving subassembly is not limited to one kind of configuration, and the configuration of the driving assembly may be selected by those skilled in the related art according to the actual requirements. In following, detailed descriptions are made regarding to the driving subassembly having one specific configuration. The driving subassembly in the following ensures that the distributor box 2 can be ejected out stably and reliably, thus improving a working life of the detergent box assembly 100 effectively.

[0029] With the detergent box assembly 100 for the washing machine according to embodiments of the present invention, regardless of the automatically inputting washing machine or the non-automatically inputting washing machine, by using a mechanical control in which the driving subassembly is fitted with the key-press 211, the distributor box 2 can be ejected out automatically or semi-automatically without the manual drawing by the user, thus improving the usage comfort. Furthermore, the mechanical control reduces a cost effectively.

[0030] In an embodiment of the present invention, as shown in Fig. 2, the detergent box 1 may include a base seat 13 and an upper cover subassembly (for example, including a first cover part 11 and a second upper body as shown in 2, in which the first cover part 11 is in an upper position and the second cover part 12 is in a lower position). The upper cover subassembly is mounted at a top of the base seat 13 so as to define a space for receiving the distributor box 2 together with the base seat 13. The driving subassembly includes a gear assembly 4, a rack 5 and a tension spring 3. The gear assembly 4 is disposed on the upper cover subassembly, and the rack 5 is provided on the upper cover subassembly and adapted to be engaged with the gear assembly 4, i.e., the rack 5 can drive a gear of the gear assembly 4 to rotate during a movement of the rack 5, or the gear of the gear assembly 4 can drive the rack 5 to move during a rotation of the gear of the gear assembly 4.

[0031] In an embodiment of the present invention, as shown in Fig. 2, the detergent box assembly 100 further includes a lock catch 222, and the lock catch 222 is associated with the key-press 221 and provided in the dis-

tributor box 2. The lock catch 222 is configured to be lockably engaged by the washing machine such that when the key-press 221 is pressed, the lock catch 222 is unlocked and disengaged by the washing machine.

5 That is, in general, the lock catch 222 may be connected with the washing machine in a lock catch manner so as to be tightly locked thereby, and after the key-press 221 is pressed, the lock catch 222 may be unlocked by the washing machine so as to be separated therefrom. After
10 the lock catch 222 is unlocked and disengaged by the washing machine, the rack 5 is driven by the tension spring 3 to enable move the distributor box 2 to be moved from the closed position to the open position.

[0032] In preferred embodiments of the present invention, the gear assembly 4 may include a damping gear 41 which may be configured as a gear having a damping function, preferably as a fluid damping gear. In an engaged movement of the damping gear 4 and the rack 5, a damping force may be generated so as to slow down
20 the movement strength and speed of the rack 5.

[0033] The rack 5 has a free end 51 (for example, a front end of the rack 5 as shown in Fig. 2, i.e., the front end of the rack 5 may be configured as the free end) adjacent to the front plate 22 of the distributor box 2 and a snap-fit end 52 (for example, a rear end of the rack 5
25 as shown in Fig. 2, i.e., the rear end of the rack 5 may be configured as the snap-fit end) away from the front plate 22 of the distributor box 2 and opposite to the free end 51 along a length direction thereof. The snap-fit end 52 of the rack 5 is configured to be engageable with the
30 rear plate of the distributor box 2, i.e., the snap-fit end 52 may be coupled with the rear plate of the distributor box 2 in a snap-fit manner. Briefly, the rack 5 is mounted in the detergent box 1 and the rear end of the rack 5 penetrates through the second cover part 12 of the detergent
35 box 1 and is engageable with the rear plate of the distributor box 2.

[0034] It should be noted that, the snap-fit manner is well known by those skilled in the related art, which thus is omitted herein and is illustrated with a specific example. Optionally, the snap-fit end 52 of the rack 5 is formed with a downwardly-extending leg 53 engageable with the rear plate of the distributor box 2, a snap-fit hole is provided in the rear plate of the distributor box 2, and the leg 53 penetrates through the upper cover subassembly
40 of the detergent box 1 (for example penetrating through the second cover part 12 downwards as shown in Fig. 2) and is inserted within the snap-fit hole, so that the rack 5 is engageable with the distributor box 2.

[0035] The tension spring 3 is disposed in the length direction of the rack 5, i.e., a tension direction of the tension spring 3 is the same with that of the length of the rack 5. The tension spring 3 has a first end 31 and a second end 32 opposite to the first end 31. The first end 31 (such as a front end of the tension spring 3 as shown
45 in Fig. 2) is adjacent to the front plate 22 of the distributor box 2 and mounted on the upper cover subassembly (such as the first upper cover part 11) of the detergent

box 1 adjacent to the front plate 22 of the distributor box 2 and the second end 32 (such as a rear end of the tension spring 3 as shown in Fig. 2) is coupled to the rack 5 and adjacent to the snap-fit end 52 of the rack 5. Optionally, the second end 32 of the tension spring 3 may be fixed to the snap-fit end 52 of the rack 5. Briefly, the tension spring 3 is mounted in the detergent box 1, the front end of the tension spring 3 is substantially fixed with the front end of the detergent box 1, and the rear end of the tension spring 3 is substantially fixed with the rear end of the rack 5 on the distributor box 2.

[0036] It should be noted that, coupling is well known by those skilled in the related art, which thus is omitted herein and is illustrated with a specific example. For example, as shown in Fig. 2, a position limiting part 54 extending upwards may be provided at the snap-fit end 52 of the rack 5, a rear hook may be provided at the second end 32 of the tension spring 3, and the rear hook may be hooked by the position limiting part 54, so that the second end 32 of the tension spring 3 can be fixed with the snap-fit end 52 of the rack 5. Thus, the tension spring 3 can be assembled with the rack 5 conveniently and rapidly.

[0037] As shown in Fig. 2, the upper cover subassembly of the detergent box 1 includes the first cover part 11 and the second cover part 12 assembled with each other. The second cover part 12 is provided with a mounting slot, which extends in the front and rear direction and penetrates through the second cover part 12 in the upper and lower direction. The rack 5 is mounted within the mounting slot of the second cover part 12 and freely movable in the front and rear direction. Thus, by providing the mounting slot, it is ensured that the rack 5 moves in the front and back direction stably without getting off track.

[0038] In this way, when the distributor box 2 is in the closed position, the distributor box 2 is received in the detergent box 1, the front end of the distributor box 2 is adjacent to the front end of the detergent box 1, and the rear end of the distributor box 2 is adjacent to the rear end of the detergent box 1. The rack 5 is movably installed in the second cover part 12 and engageable with the distributor box 2, and the tension spring 3 is mounted between the first cover part 11 and the rack 5. The front end of the tension spring 3 is fixed to a front end of the first cover part 11, and the rear end of the tension spring 3 is fixed to the rear end of the rack 5, so that the tension spring 3 is in a tension state.

[0039] When a force acted on the tension spring 3 is removed, the tension spring 3 tends to contract and recover. At this time, the front end of the tension spring 3 is fixed to the first cover part 11 and does not move, and the rear end of the tension spring 3 drives the rear end of the rack 5 to move forwards. The rack 5 drives the distributor box 2 connected with the rack 5 to move forwards at the same time, so that the distributor box 2 can be ejected out. When the distributor box 2 moves to the open position, the tension spring 3 may just contract to an original length state.

[0040] Thus, by providing the tension spring 3, the distributor box 2 moves from the closed position to the open position under a spring force, without the manual drawing, thus improving the usage comfort. Preferably, the tension spring 3 may be configured as a cylindrical tension spring. In addition, configuration and operating principle of the tension spring 3 are well known by those skilled in the related art, which are omitted herein.

[0041] In an embodiment of the present invention, the gear assembly 4 includes at least one damping gear 41 and the damping gear 41 may be mounted at the first cover part 12 and disposed adjacent to a side edge of the mounting slot. Thus, when the rack 5 and the distributor box 2 are ejected out together under a force of the tension spring 3, since the damping gear 41 is disposed at the first cover part 12 which is stationary, the engaged movement is generated between the rack 5 and the damping gear 41. That is, the rack 5 drives the damping gear 41 to rotate when moving forwards with respect to the gear assembly 4, and thus the damping gear 41 plays a damping role, which slows down a ejecting strength and the speed of the rack 5 and the distributor box 2, and results in that the distributor box 2 can be ejected out stably.

[0042] Further preferably, as shown in Fig. 2, the gear assembly 4 may include a plurality of damping gears 41 and the plurality of damping gears 41 is disposed adjacent to a same side of the mounting slot, i.e., the plurality of damping gears 41 is disposed adjacent to the same side of the mounting slot in a width direction of the mounting slot, and at this time, an engaging tooth may be only provided at one side of the rack 5 in a width direction of the rack 5 so as to be engaged with the plurality of damping gears 41 respectively. Thus, by providing the plurality of damping gears 41, a more effective damping function can be obtained, so that the distributor box 2 can be ejected out forwards more stably. In addition, since the plurality of damping gears 41 is mounted at the same side of the mounting slot, it is convenient to assemble, a high space utilization is provided and a manufacturing difficulty of the rack 5 is reduced.

[0043] Preferably, the damping gear 41 has thereof a horizontally-arranged rotation axis, so that the damping gear 41 can roll in a vertical plane. In this way, the engaging tooth of the rack 5 may be formed by depressing an upper end surface of the rack 5 down, so that it is convenient to manufacture, and the detergent box assembly 100 has a more compact configuration and a more reliable operating effect.

[0044] With the detergent box assembly 100 for the washing machine according to embodiments of the present invention, via the fitting among the tension spring 3, the gear assembly 4 and the rack 5, a simple configuration is provided and the cost is saved greatly. Furthermore, the ejecting strength and ejecting speed of the distributor box 2 are controlled effectively, so that the distributor box 2 can be ejected out freely and stably, and thus the operating reliability of the distributor box 2 and

the operating life of the detergent box assembly 100 can be improved.

[0045] In some embodiments of the present disclosure, as shown in Figs. 2 and 3, the key-press 221 is preferably provided in the center of the front plate 22, so that it is convenient for the user to operate. Optionally, the lock catch 222 may be fitted with the upper cover subassembly of the detergent box 1 in the lock catch manner. In a preferred embodiment of the present invention, the lock catch 222 may be fitted with the second cover part 12 of the detergent box 1 in the lock catch manner. For example, a lock hole is provided in the second cover part 12, and the lock catch 222 penetrates through the front end of the distributor box 2 and movable therein in an up and down direction. Specifically, a first compression spring 2231 is provided at a lower end of the lock catch 222 and a second compression spring 2232 is provided between the key-press 221 and the lock catch 222.

[0046] In general, the first compression spring 2231 and the second compression spring 2232 are in an original length state, and the first compression spring 2231 raises the lock catch 222 to be inserted into the lock hole of the second cover part 12, so as to be lockably engaged by the washing machine. When the key-press 221 is pressed backwards, the key-press 221 pushes the second compression spring 2232 to be compressed backwards and the second compression spring 2232 pushes the lock catch 222 to move downwards to be out of the lock hole, so as to be separated from the washing machine, in which the lock catch 222 pushes the first compression spring 2231 to be compressed downwards at the same time when the lock catch 222 moves downwards.

[0047] When a force acted on the key-press 221 is removed, the first compression spring 2231 is ejected up under a spring force thereof to push the lock catch 222 to move upwards. At the same time, the lock catch 222 pushes the second compression spring 2232 forwards to return to its original length, and the second compression spring 2232 pushes the key-press 221 to move forwards to return to its original position.

[0048] Thus, when the distributor box 2 is in the closed position, the lock catch 222 is lockably engaged in the washing machine, and the tension spring 3 is in the tension state (as shown in Figs. 4 and 5). When the key-press 221 in the front surface of the distributor box 2 is pressed, the lock catch 222 breaks away from the lock hole in the washing machine, and the tension spring 3 contracts to a compression state under its own spring force (as shown in Figs. 7 and 8), so as to drive the distributor box 2 to be ejected out forwards to the open position, and at this time, the user can put the laundry treat agent into the receiving chamber 211 ejected out. Certainly, the user may release the key-press 211 after pressing the key-press 221 down, and then the lock catch 222 can be ejected up automatically and the key-press 221 can return forwards to its original position at the same

time.

[0049] After the user has put the laundry treat agent (such as the washing powder, the laundry detergent and the softener) into the receiving chamber 211 of the distributor box 2, the user may push the distributor box 2 backwards until the lock catch 222 touches the second cover part 12, and then, when the distributor box 2 is further pushed backwards, the second cover part 12 pushes the lock catch 222 to move downwards with respect to the second cover part 12 and to compress the first compression spring 2231. When the lock catch 222 moves backwards to a position in which the lock catch 222 is opposed to the lock hole, a downward pressure is no longer acted on the lock catch 222, so that the lock catch 222 can be ejected up automatically under the spring force of the first compression spring 2231 so as to be lockably engaged in the washing machine, so that the distributor box 2 can be remained in the closed position.

[0050] It should be noted that, the lock catch 222 may include a first guiding surface 2221 and a second guiding surface 2222. The first guiding surface 2221 is provided at a front end of the lock catch 222 and extends forwards and downwards, and the second guiding surface 2222 is provided at an upper end of the lock catch 222 and extends backwards and downwards. By providing the first guiding surface 2221, it is ensured that the lock catch 222 can move downwards when the key-press 221 is pushed backwards. By providing the second guiding surface 2222, the second cover part 12 can push the lock catch 222 to move downwards when the distributor box 2 is pushed backwards. Certainly, the present invention is not limited to this.

[0051] Briefly, after the key-press 221 is pressed, the distributor box 2 is driven by the tension spring 3 to move forwards to the open position from the closed position. In this way, by providing the key-press 221 and the tension spring 3, the distributor box 2 can automatically move to the open position from the closed position only by pressing the key-press 221, without the manual drawing, thus resulting in a better usage comfort. Furthermore, by providing the key-press 221, overall aesthetics and neatness of the detergent box assembly 100 are improved.

[0052] Certainly, a configuration and a disposition position of the key-press 221 are not limited to this, and a technical solution of locking and catching the distributor box 2 in the closed position and releasing the distributor box 2 is not limited to the fitting of the key-press 221 and the lock catch 222 as shown in Fig. 2. For example, when the distributor box 2 moves to the closed position, the distributor box 2 may be locked by a hasp configuration, and then the user may unhasp the hasp configuration by himself, so that the distributor box 2 can be ejected out forwards. Embodiments thereof are well known by those skilled in the related art, which are omitted herein.

[0053] Specifically, the detergent box assembly 100 for the washing machine according to above embodi-

ments of the present invention may be used in the washing machine, and thus a washing machine according to embodiments of a second aspect of the present invention may include the detergent box assembly 100 according to the above embodiments of the present invention. In some embodiments, the washing machine further includes a machine housing assembly and the machine housing assembly has the detergent box 1. In some embodiments, the machine housing assembly includes a machine body and the detergent box 1, and the detergent box 1 is fixedly mounted in the machine body. In addition, other features of the detergent box assembly 100 have been described in detail above, and are omitted herein.

[0054] With the washing machine according to embodiments of the present invention, by providing the driving subassembly and the key-press 221, the distributor box 2 can be ejected out smoothly without the manual drawing, thus improving the usage comfort of the washing machine. In addition, via the fitting among the tension spring 3, the gear assembly 4 and the rack 5, the ejecting strength and ejecting speed of the distributor box 2 are controlled effectively, so that the distributor box 2 can be ejected out freely and stably, and thus the operating reliability of the distributor box 2 and the operating life of the detergent box assembly 100 can be improved. Moreover, other configurations and operations of the washing machine according to embodiments of the present invention are known by those skilled in the related art and omitted herein.

[0055] In the specification, unless specified or limited otherwise, relative terms such as "central", "longitudinal", "lateral", "length", "width", "thickness", "up", "down", "front", "rear", "right", "left", "vertical", "horizontal", "top", "bottom", "inner", "outer", as well as derivative thereof (e.g., "horizontally", "downwardly", "upwardly", etc.) should be construed to refer to the orientation as then described or as shown in the drawings under discussion. These relative terms are for convenience of description and do not require that the present disclosure be constructed or operated in a particular orientation.

[0056] In the description of the present disclosure, unless specified or limited otherwise, it should be noted that, terms "mounted", "connected" and "coupled" may be understood broadly, such as permanent connection or detachable connection, electronic connection or mechanical connection, direct connection or indirect connection via intermediary, inner communication or interaction between two elements. Those having ordinary skills in the art should understand the specific meanings in the present disclosure according to specific situations.

[0057] In the description of the present disclosure, a structure in which a first feature is "on" a second feature may include an embodiment in which the first feature directly contacts the second feature, and may also include an embodiment in which an additional feature is formed between the first feature and the second feature so that the first feature does not directly contact the second feature, unless otherwise specified. Furthermore, a

first feature "on", "above", or "on top of" a second feature may include an embodiment in which the first feature is right "on", "above", or "on top of" the second feature, and may also include an embodiment in which the first feature is not right "on", "above", or "on top of" the second feature, or just means that the first feature has a sea level elevation larger than the sea level elevation of the second feature. While first feature "beneath", "below", or "on bottom of" a second feature may include an embodiment in which the first feature is right "beneath", "below", or "on bottom of" the second feature, and may also include an embodiment in which the first feature is not right "beneath", "below", or "on bottom of" the second feature, or just means that the first feature has a sea level elevation smaller than the sea level elevation of the second feature.

[0058] Reference throughout this specification to "an embodiment", "some embodiments", "one embodiment", "another example", "an example", "a specific example", or "some examples", means that a particular feature, structure, material, or characteristic described in connection with the embodiment or example is included in at least one embodiment or example of the present invention. Thus, the appearances of the phrases such as "in some embodiments", "in one embodiment", "in an embodiment", "in another example", "in an example", "in a specific example", or "in some examples", in various places throughout this specification are not necessarily referring to the same embodiment or example of the present invention. Furthermore, the particular features, structures, materials, or characteristics may be combined in any suitable manner in one or more embodiments or examples.

35 Claims

1. A detergent box assembly (100) for a washing machine, comprising:

a detergent box (1) provided with an upper cover subassembly;

a distributor box (2) having a front plate (22), a rear plate and a receiving chamber (211) provided therebetween, said receiving chamber (211) configured to store a laundry treat agent, the distributor box (2) being movably disposed within the detergent box (1) and adapted to move between an open position and a closed position, a key-press (221) being provided in the front plate (22); a lock catch (222) associated with the key-press (221) and provided at the distributor box (2); and

a driving subassembly configured to drive the distributor box (2) to move from the closed position to the open position when the key-press (221) is pressed; **characterized in that** the driving subassembly comprises:

a gear assembly (4);
 a rack (5); and
 a tension spring (3); wherein the gear assembly (4) is disposed on the upper cover subassembly of the detergent box (1);

the rack (5) is provided on the upper cover subassembly of the detergent box (1) and adapted to be engaged with the gear assembly (4), the rack (5) having a free end (51) adjacent to the front plate (22) of the distributor box (2) and a snap-fit end (52) away from the front plate (22) of the distributor box (2) and opposite to the free end (51) along a length direction thereof, the snap-fit end (52) of the rack (5) being configured to be engageable with the rear plate of the distributor box (2) and formed with a downwardly-extending leg (53) engageable with the rear plate of the distributor box (2); and
 the tension spring (3) is disposed along the length direction of the rack (5) and has a first end (31) and a second end (32) opposite to the first end (31), the first end (31) being adjacent to the front plate (22) of the distributor box (2) and mounted on the upper cover subassembly of the detergent box (1), the second end (32) being coupled to the rack (5) and adjacent to the snap-fit end (52) of the rack (5); wherein the lock catch (222) is configured to be lockably engaged by the washing machine such that when the key-press (221) is pressed, the lock catch (222) is unlocked and disengaged by the washing machine, the rack (5) is driven by the tension spring (3) to enable the distributor box (2) to be moved from the closed position to the open position, and
 the upper cover subassembly of the detergent box (1) comprises a first cover part (11) and a second cover part (12) assembled with each other, the second cover part (12) is provided with a mounting slot and the rack (5) is mounted within the mounting slot of the second cover part (12).

2. The detergent box assembly (100) for the washing machine according to claim 1, wherein the second end (32) of the tension spring (3) is fixed to the snap-fit end (52) of the rack (5).
3. The detergent box assembly (100) for the washing machine according to claim 1, wherein the gear assembly (4) comprises at least one damping gear (41) disposed adjacent to a side edge of the mounting slot.
4. The detergent box assembly (100) for the washing machine according to claim 3, wherein the gear assembly (4) comprises a plurality of damping gears

(41) disposed adjacent to a same side of the mounting slot.

5. The detergent box assembly (100) for the washing machine according to claim 3 or 4, wherein the damping gear (41) defines thereof a horizontally-arranged rotation axis.
6. The detergent box assembly (100) for the washing machine according to claim 1, further comprising a lock catch (222) associated with the key-press (221) and provided at the distributor box (2), the lock catch (222) being lockably engaged on the upper cover subassembly of the detergent box (1) so as to keep the lock catch (222) located at a lock-catch manner on the washing machine.
7. The detergent box assembly (100) for the washing machine according to claim 6, wherein the upper cover assembly of the detergent box (1) comprises a first cover part (11) and a second cover part (12) assembled with each other, the lock catch (222) is lockably engaged on the second cover part (12) of the detergent box (1) to keep the lock catch (222) in the lock-catch manner.
8. A washing machine, comprising the detergent box assembly (100) according to any one of claims 1-7, wherein the detergent box (1) is included in a machine housing assembly of the washing machine.

Patentansprüche

1. Waschmittelboxanordnung (100) für eine Waschmaschine, umfassend:
 - eine Waschmittelbox (1), die mit einer oberen Abdeckungsunteranordnung versehen ist;
 - eine Verteilerbox (2) mit einer Frontplatte (22), einer Rückplatte und einer dazwischen vorgesehenen Aufnahmekammer (211), wobei die Aufnahmekammer (211) konfiguriert ist, um ein Wäschebehandlungsmittel zu bevorraten, wobei die Verteilerbox (2) beweglich in der Waschmittelbox (1) angeordnet ist und geeignet ist, sich zwischen einer offenen Position und einer geschlossenen Position zu bewegen, wobei eine Drucktaste (221) in der Frontplatte (22) vorgesehen ist; wobei ein Fangriegel (222) mit der Drucktaste (221) assoziiert ist und an der Verteilerbox (2) vorgesehen ist; und
 - eine Antriebsunteranordnung, die konfiguriert ist, um die Verteilerbox (2) anzutreiben, so dass diese sich von der geschlossenen Position zu der offenen Position bewegt, wenn die Drucktaste (221) gedrückt wird;**dadurch gekennzeichnet, dass** die Antriebs-

unteranordnung umfasst:

eine Getriebearordnung (4);
 eine Zahnstange (5); und
 eine Spannungsfeder (3);
 wobei die Getriebearordnung (4) an der
 oberen Abdeckungsunteranordnung der
 Waschmittelbox (1) angeordnet ist;
 wobei die Zahnstange (5) an der oberen Ab-
 deckungsunteranordnung der Waschmit-
 telbox (1) vorgesehen ist und geeignet ist,
 mit der Getriebearordnung (4) im Eingriff
 zu sein, wobei die Zahnstange (5) ein freies
 Ende (51) benachbart zu der Frontplatte
 (22) der Verteilerbox (2) und ein Einschnap-
 pendende (52) entfernt von der Frontplatte (22)
 der Verteilerbox (2) und gegenüberliegend
 dem freien Ende (51) entlang einer Längs-
 richtung derselben aufweist, wobei das Ein-
 schnappende (52) der Zahnstange (5) kon-
 figuriert ist, dass es mit der Rückplatte der
 Verteilerbox (2) im Eingriff stehen kann, und
 mit einem sich nach unten erstreckenden
 Bein (53) ausgebildet ist, das mit der Rück-
 platte der Verteilerbox (2) im Eingriff stehen
 kann; und
 wobei die Spannungsfeder (3) entlang der
 Längsrichtung der Zahnstange (5) ange-
 ordnet ist und ein erstes Ende (31) sowie
 ein zweites Ende (32) gegenüberliegend
 dem ersten Ende (31) aufweist, wobei das
 erste Ende (31) benachbart zu der Front-
 platte (22) der Verteilerbox (2) ist und an
 der oberen Abdeckungsunteranordnung
 der Waschmittelbox (1) montiert ist, wobei
 das zweite Ende (32) mit der Zahnstange
 (5) und benachbart zu dem Einschnap-
 pendende (52) der Zahnstange (5) gekoppelt
 ist; wobei der Fangriegel (222) konfiguriert
 ist, um verriegelbar mit der Waschmaschine
 im Eingriff zu stehen, so dass, wenn die
 Drucktaste (221) gedrückt wird, der
 Fangriegel (222) entriegelt und von der
 Waschmaschine getrennt wird, wobei die
 Zahnstange (5) durch die Spannungsfeder
 (3) angetrieben wird, um die Verteilerbox
 (2) zu befähigen, von der geschlossenen
 Position zu der offenen Position bewegt zu
 werden, und wobei die obere Abdeckungs-
 unteranordnung der Waschmittelbox (1) einen
 ersten Abdeckungsteil (11) und einen zweiten
 Abdeckungsteil (12) umfasst, die zusammen-
 gebaut sind, wobei der zweite Abdeckungs-
 teil (12) mit einem Montageschlitz versehen
 ist und die Zahnstange (5) in dem Monta-
 geschlitz des zweiten Abdeckungsteils (12)
 montiert ist.

2. Waschmittelboxanordnung (100) für die Waschma-
 schine nach Anspruch 1, wobei das zweite Ende (32)
 der Spannungsfeder (3) an dem Einschnappende
 (52) der Zahnstange (5) fixiert ist.
3. Waschmittelboxanordnung (100) für die Waschma-
 schine nach Anspruch 1, wobei die Getriebearord-
 nung (4) wenigstens ein Dämpfungsgetriebeelee-
 ment (41) aufweist, das benachbart zu einer Seiten-
 kante des Montageschlitzes angeordnet ist.
4. Waschmittelboxanordnung (100) für die Waschma-
 schine nach Anspruch 3, wobei die Getriebearord-
 nung (4) eine Vielzahl von Dämpfungsgetriebeelee-
 menten (41) aufweist, die benachbart zu einer sel-
 ben Seite des Montageschlitzes angeordnet sind.
5. Waschmittelboxanordnung (100) für die Waschma-
 schine nach Anspruch 3 oder 4, wobei ihr Dämpf-
 ungsgetriebe (41) eine horizontal angeordnete
 Drehachse definiert.
6. Waschmittelboxanordnung (100) für die Waschma-
 schine nach Anspruch 1, die weiterhin einen Fang-
 riegel (222) umfasst, der mit der Drucktaste (221)
 assoziiert ist und an der Verteilerbox (2) angeordnet
 ist, wobei der Fangriegel (222) verriegelbar an der
 oberen Abdeckungsanordnung der Waschmittelbox
 (1) im Eingriff ist, um so den Fangriegel (222) in der
 Weise eines Fangriegels an der Waschmaschine
 angeordnet zu halten.
7. Waschmittelboxanordnung (100) für die Waschma-
 schine nach Anspruch 6, wobei die obere Abde-
 ckungsanordnung der Waschmittelbox (1) einen ers-
 ten Abdeckungsteil (11) und einen zweiten Abde-
 ckungsteil (12) umfasst, die zusammengebaut sind,
 wobei der Fangriegel (222) verriegelbar mit dem
 zweiten Abdeckungsteil (12) der Waschmittelbox (1)
 im Eingriff ist, um den Fangriegel (222) in der
 Weise eines Fangriegels zu halten.
8. Waschmaschine mit einer Waschmittelboxanord-
 nung (100) nach einem der Ansprüche 1 bis 7, wobei
 die Waschmittelbox (1) in einer Maschinengehäuse-
 anordnung der Waschmaschine enthalten ist.

Revendications

1. Ensemble de compartiment à détergent (100) pour
 une machine à laver, comprenant :
 un compartiment à détergent (1) pourvu d'un
 sous-ensemble de couvercle supérieur ;
 un compartiment distributeur (2) ayant une pla-
 que avant (22), une plaque arrière et une cham-
 bre de réception (211) agencée entre celles-ci,

ladite chambre de réception (211) étant configurée pour stocker un agent de traitement de linge, le compartiment distributeur (2) étant disposé de manière mobile à l'intérieur du compartiment à détergent (1) et adapté pour se déplacer 5 entre une position ouverte et une position fermée, une touche à pression (221) étant fournie dans la plaque avant (22) ; un loquet de verrou (222) étant associé à la touche à pression (221) et agencé au niveau du compartiment distributeur (2) ; et 10 un sous-ensemble d'entraînement configuré pour entraîner le compartiment distributeur (2) pour qu'il se déplace de la position fermée à la position ouverte quand la touche à pression (221) est pressée ; 15

caractérisé en ce que le sous-ensemble d'entraînement comprend :

un ensemble à engrenages (4) ; 20
une crémaillère (5) ; et
un ressort de tension (3)
dans lequel l'ensemble à engrenages (4) est disposé sur le sous-ensemble de couvercle supérieur du compartiment à détergent (1) ; 25
la crémaillère (5) est agencée sur le sous-ensemble de couvercle supérieur du compartiment à détergent (1) et adaptée pour entrer en prise avec l'ensemble à engrenage (4), la crémaillère (5) ayant une extrémité libre (51) adjacente à la plaque avant (22) du compartiment distributeur (2) et une extrémité encliquetable (52) en éloignement de la plaque avant (22) du compartiment distributeur (2) et opposée à l'extrémité libre (51) le long d'une direction dans le sens de la longueur de celle-ci, l'extrémité encliquetable (52) de la crémaillère (5) étant configurée pour pouvoir entrer en prise avec la plaque arrière du compartiment distributeur (2) et formée avec une patte s'étendant vers le bas (53) pouvant entrer en prise avec la plaque arrière du compartiment distributeur (2) ; et 30
le ressort de tension (3) est disposé le long de la direction dans le sens de la longueur de la crémaillère (5) et a une première extrémité (31) et une seconde extrémité (32) opposée à la première extrémité (31), la première extrémité (31) étant adjacente à la plaque avant (22) du compartiment distributeur (2) et montée sur le sous-ensemble de couvercle supérieur du compartiment à détergent (1), la seconde extrémité (32) étant couplée à la crémaillère (5) et adjacente à l'extrémité encliquetable (52) de la crémaillère (5) ; 35
40
45
50
55

dans lequel le loquet de verrou (222) est configuré pour être en prise de manière verrouillable par la machine à laver de telle sorte que lorsque la touche à pression (221) est pressée, le loquet de verrou (222) est déverrouillé et désengagé par la machine à laver, la crémaillère (5) est entraînée par le ressort de tension (3) pour permettre le déplacement du compartiment distributeur (2) de la position fermée à la position ouverte, et
le sous-ensemble de couvercle supérieur du compartiment à détergent (1) comprend une première partie de couvercle (11) et une seconde partie de couvercle (12) assemblées l'une à l'autre, la seconde partie de couvercle (12) est pourvue d'une rainure de montage et la crémaillère (5) est montée à l'intérieur de la rainure de montage de la seconde partie de couvercle (12).

2. Ensemble de compartiment à détergent (100) pour une machine à laver selon la revendication 1, dans lequel la seconde extrémité (32) du ressort de tension (3) est fixée à l'extrémité encliquetable (52) de la crémaillère (5).
3. Ensemble de compartiment à détergent (100) pour une machine à laver selon la revendication 1, dans lequel l'ensemble à engrenages (4) comprend au moins un engrenage d'amortissement (41) disposé de manière adjacente à un bord latéral de la rainure de montage.
4. Ensemble de compartiment à détergent (100) pour une machine à laver selon la revendication 3, dans lequel l'ensemble à engrenages (4) comprend une pluralité d'engrenages d'amortissement (41) disposés de manière adjacente à un même côté de la rainure de montage.
5. Ensemble de compartiment à détergent (100) pour une machine à laver selon la revendication 3 ou 4, dans lequel l'engrenage d'amortissement (41) définit à partir de là un axe de rotation agencé horizontalement.
6. Ensemble de compartiment à détergent (100) pour une machine à laver selon la revendication 1, comprenant en outre un loquet de verrou (222) associé à la touche à pression (221) et agencé au niveau du compartiment distributeur (2), le loquet de verrou (222) étant en prise de manière verrouillable sur le sous-ensemble de couvercle supérieur du compartiment à détergent (1) de façon à maintenir le loquet de verrou (222) situé d'une manière verrouillée sur la machine à laver.

7. Ensemble de compartiment à détergent (100) pour une machine à laver selon la revendication 6, dans lequel l'ensemble de couvercle supérieur du compartiment à détergent (1) comprend une première partie de couvercle (11) et une seconde partie de couvercle (12) assemblées l'une à l'autre, le loquet de verrou (222) est en prise de manière verrouillable sur la seconde partie de couvercle (12) du compartiment à détergent (1) de façon à maintenir le loquet de verrou (222) dans la manière verrouillée. 5 10
8. Machine à laver, comprenant l'ensemble de compartiment à détergent (100) selon l'une quelconque des revendications 1 à 7, dans laquelle le compartiment à détergent (1) est inclus dans un ensemble de boîtier de la machine à laver. 15

20

25

30

35

40

45

50

55

2

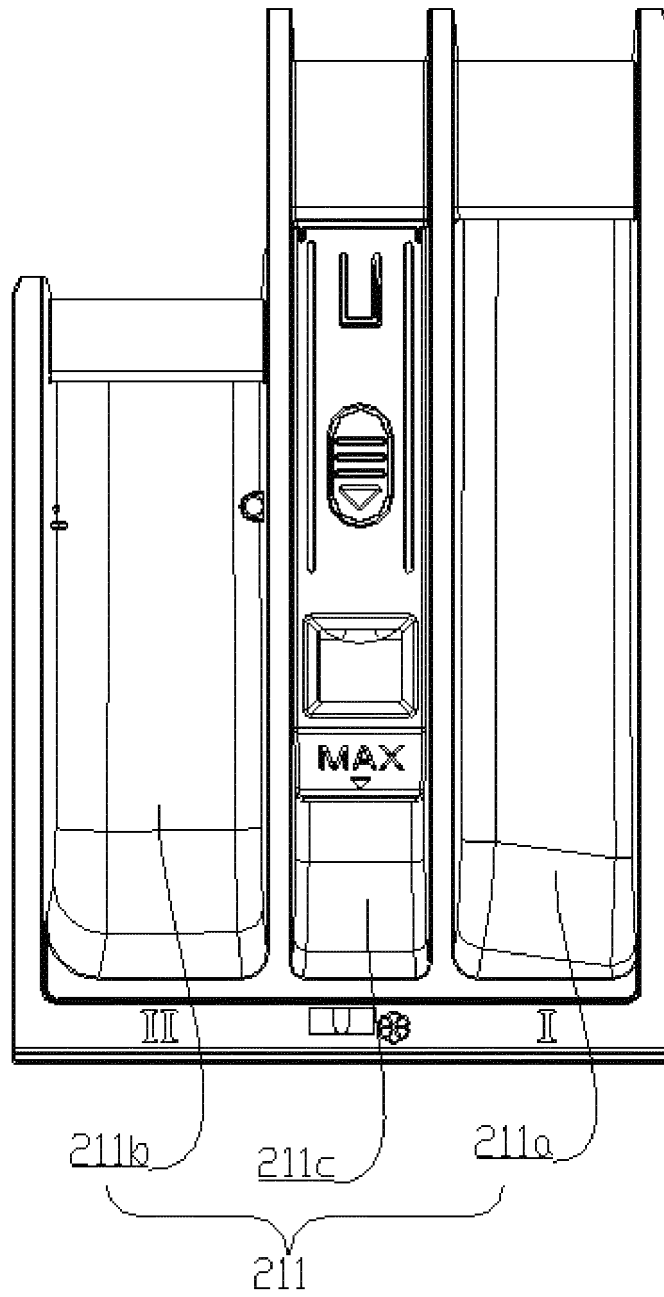

Fig. 1

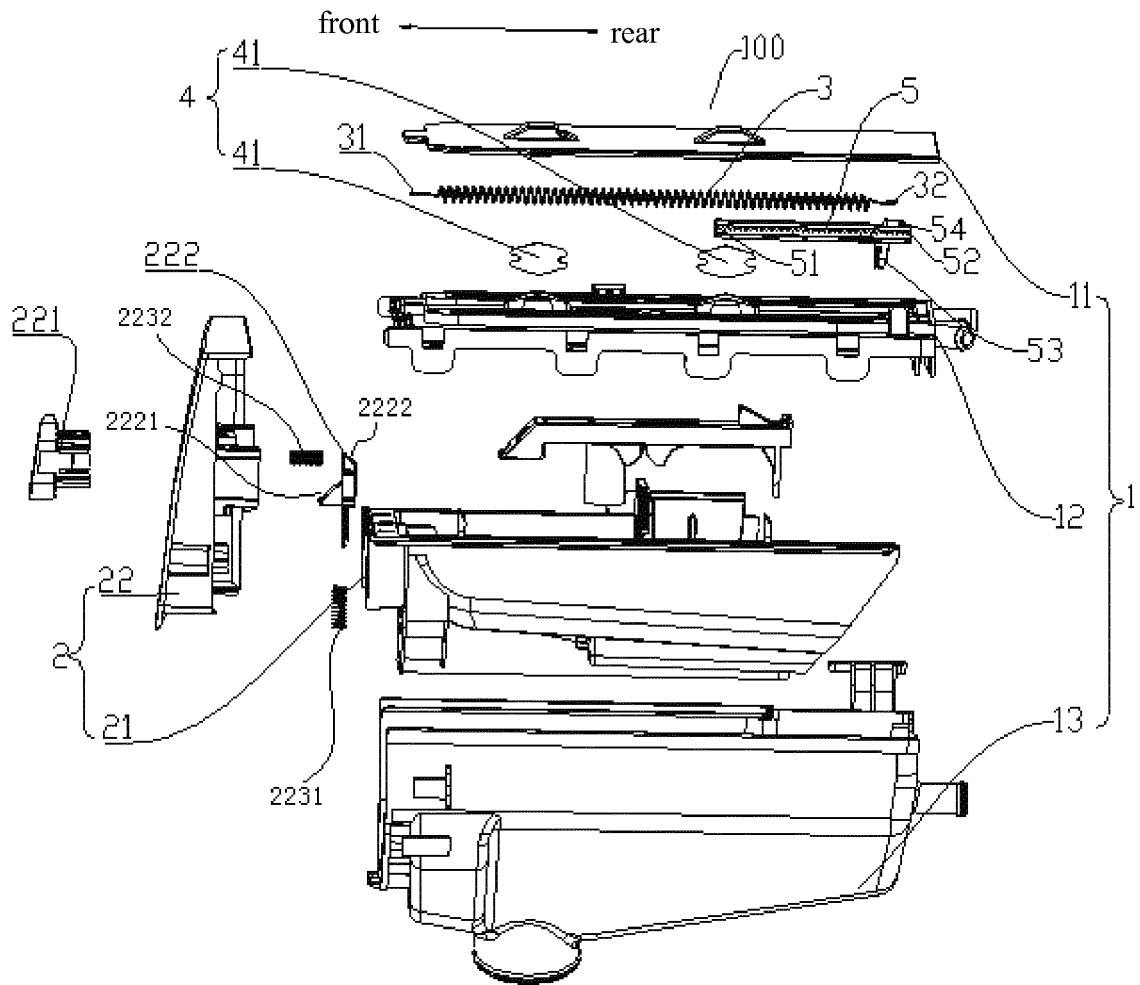

Fig. 2

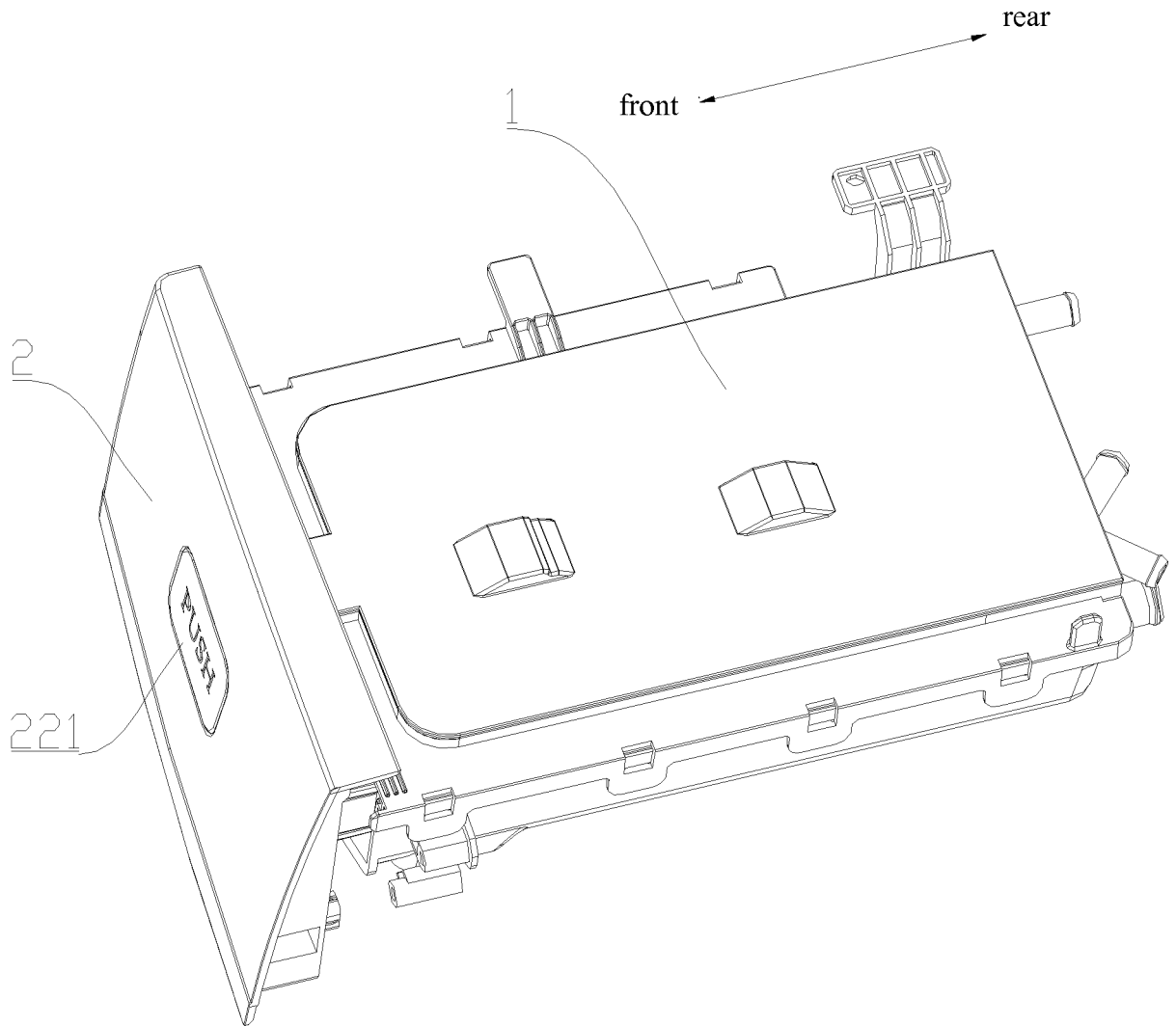

Fig. 3

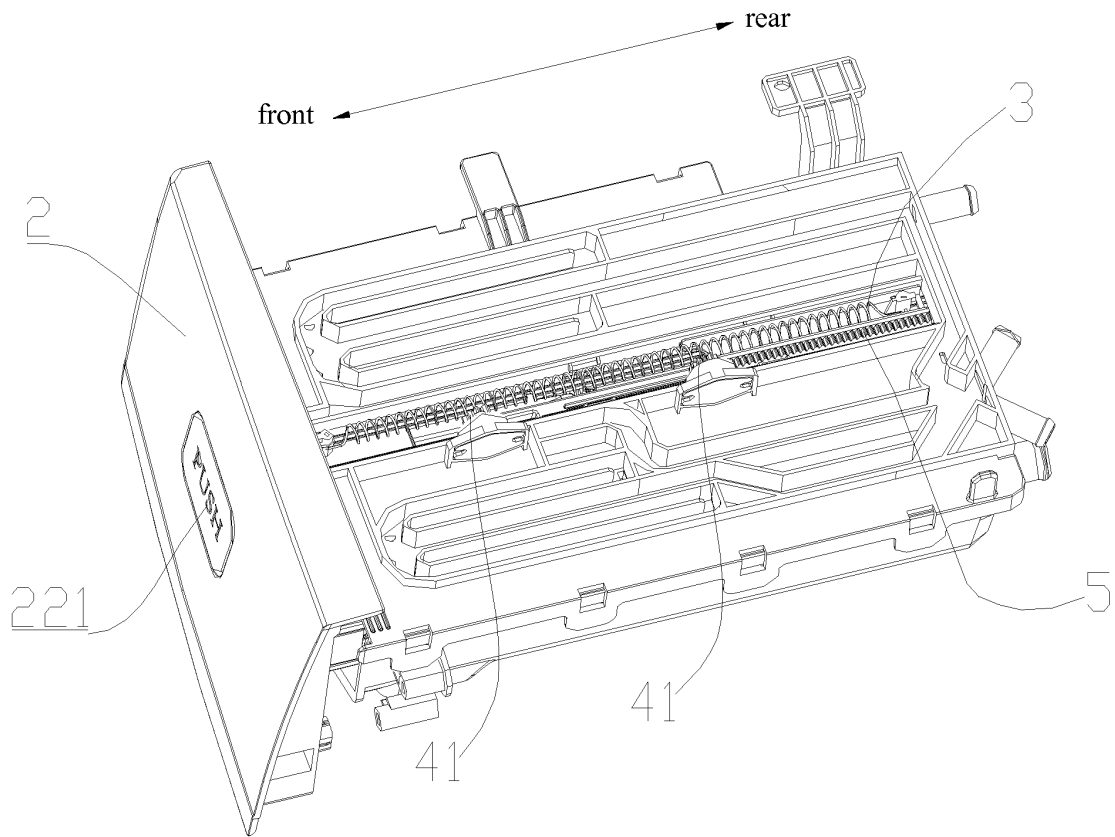

Fig. 4

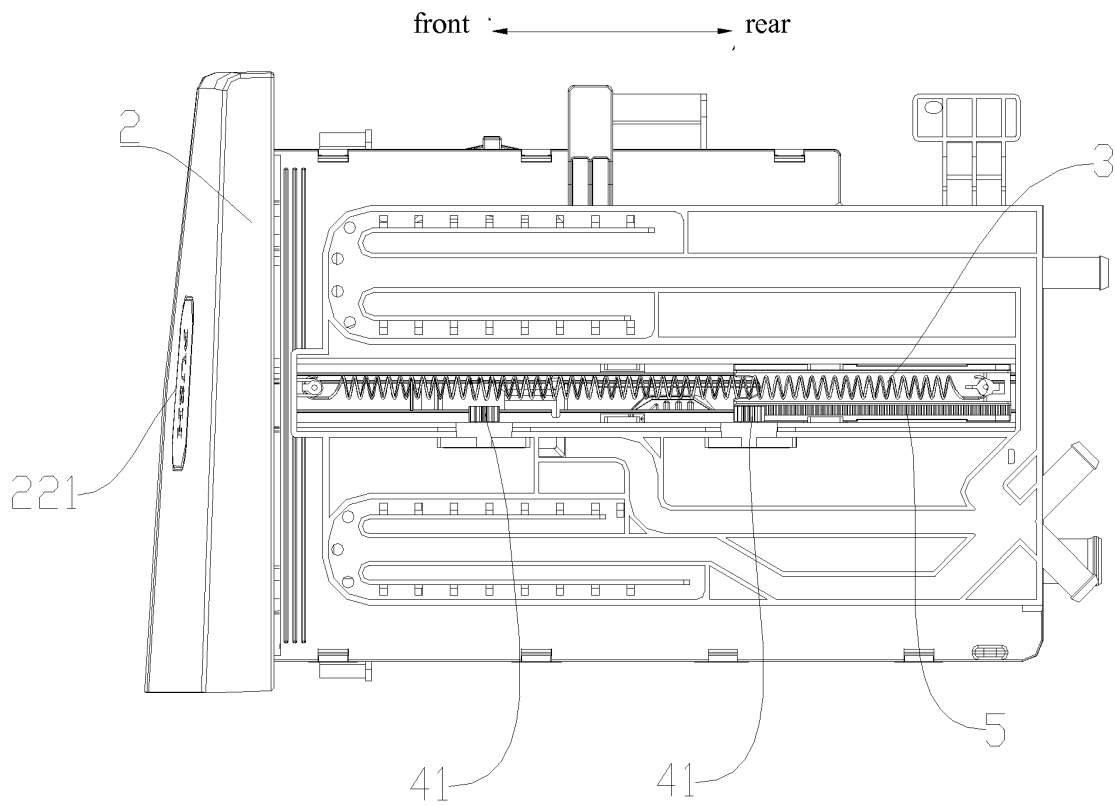

Fig. 5

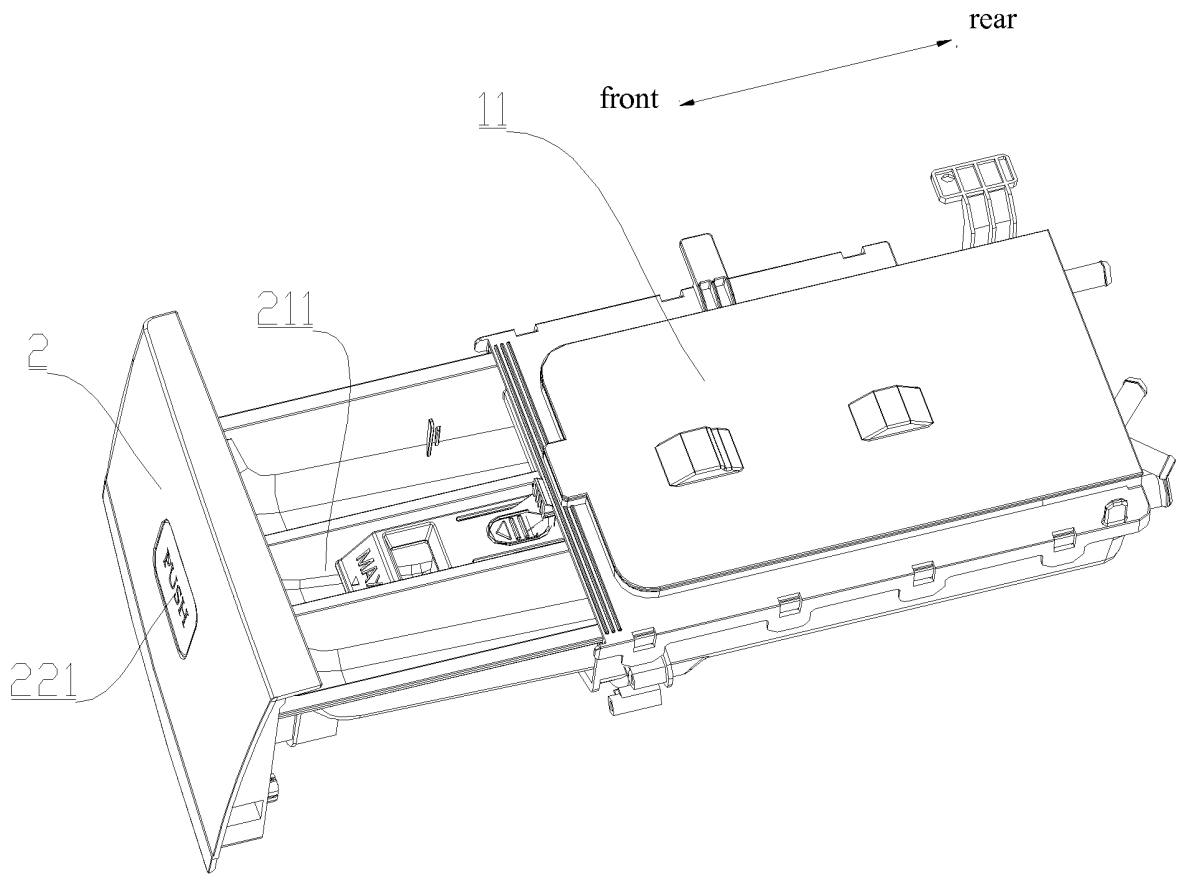

Fig. 6

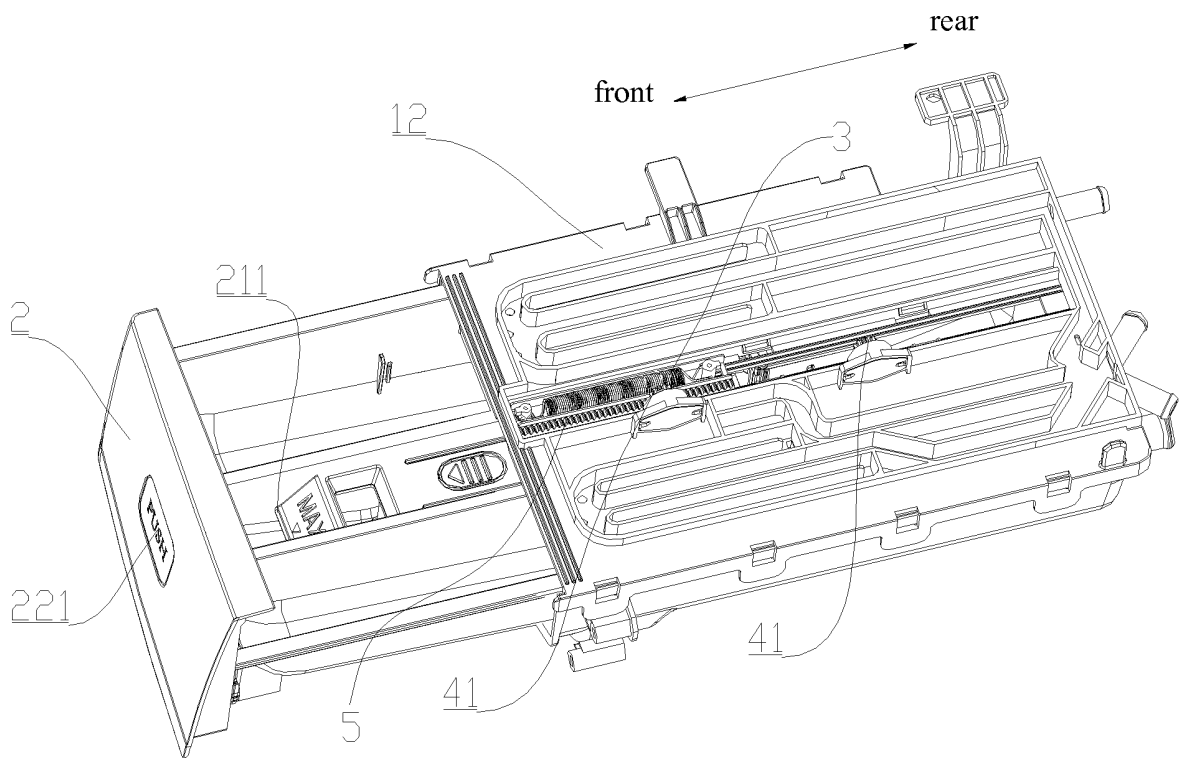

Fig. 7

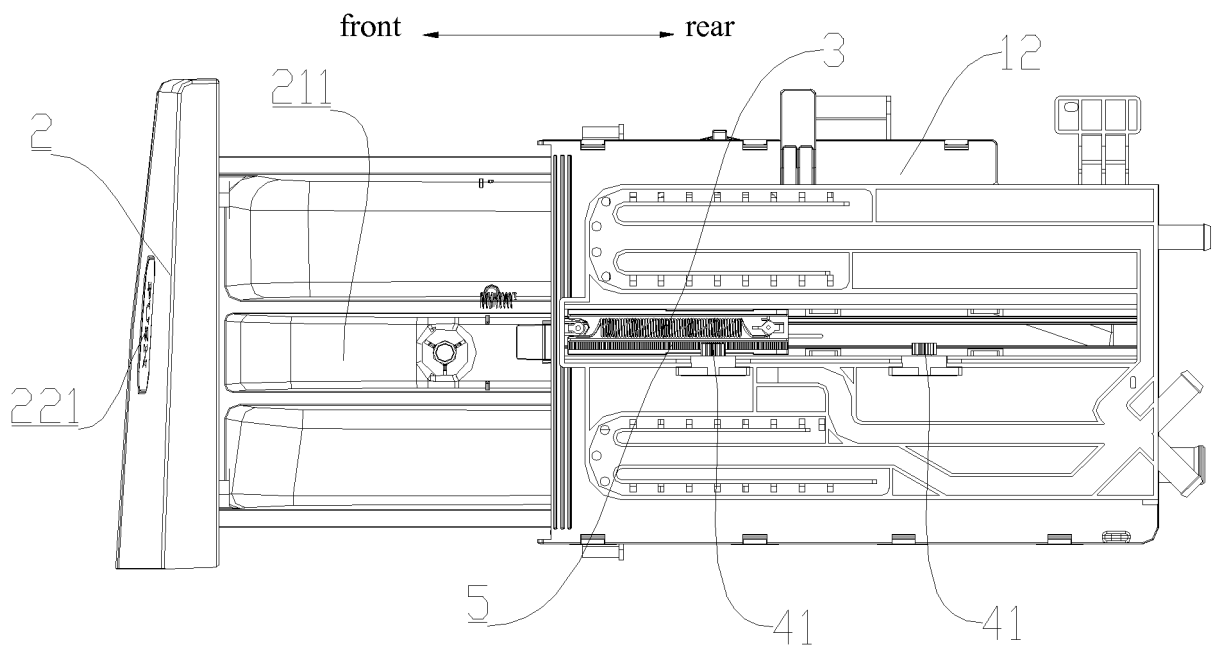

Fig. 8

REFERENCES CITED IN THE DESCRIPTION

This list of references cited by the applicant is for the reader's convenience only. It does not form part of the European patent document. Even though great care has been taken in compiling the references, errors or omissions cannot be excluded and the EPO disclaims all liability in this regard.

Patent documents cited in the description

- US 2009261697 A1 [0003]
- US 20090322195 A1 [0003]
- EP 1403415 A2 [0003]
- EP 0465800 A1 [0003]