



(12) **EUROPEAN PATENT APPLICATION**

(43) Date of publication:
19.10.2016 Bulletin 2016/42

(51) Int Cl.:
B65D 47/08 (2006.01) B65D 51/30 (2006.01)

(21) Application number: **15305573.6**

(22) Date of filing: **16.04.2015**

(84) Designated Contracting States:
AL AT BE BG CH CY CZ DE DK EE ES FI FR GB GR HR HU IE IS IT LI LT LU LV MC MK MT NL NO PL PT RO RS SE SI SK SM TR
 Designated Extension States:
BA ME
 Designated Validation States:
MA

(72) Inventors:
 • **Bois, Dominique**
02310 MONTREUIL AUX LIONS (FR)
 • **Logel, Valère**
92300 LEVALLOIS PERRET (FR)

(74) Representative: **Hoffmann Eitle**
Patent- und Rechtsanwälte PartmbB
Arabellastraße 30
81925 München (DE)

(71) Applicant: **Clariant Production (France) S.A.S.**
94603 Choisy le Roi (FR)

(54) **TAMPER-EVIDENT CLOSURE AND TAMPER-EVIDENT CLOSURE AND CONTAINER ASSEMBLY**

(57) A tamper-evident closure for the attachment to a container body comprises a cap portion (3) comprising a top wall (2) and a peripheral wall (7) extending downwardly from the top wall (2), the cap portion (3) preferably forming a flip-top closure (1), an attachment portion (4) preferably aligned with the peripheral wall (7), a tamper-proof means (6) arranged and integrally formed between the cap portion (3) and the attachment portion (4), and a hinge portion (10) comprising at least one wall section (11; 11a, 11b) which is integrally formed with the peripheral wall (7) and the attachment portion (4) and

connects the cap portion (3) and the attachment portion (4). The at least one wall section (11; 11a, 11b) of the hinge portion (10) is formed between at least two cut outs (12; 12, 13; 12, 14), the at least one wall section (11; 11a, 11b) of the hinge portion (10) does not extend beyond an envelope defined by an outer surface of the peripheral wall (7) and an outer surface of the attachment portion (4) and the at least one wall section (11; 11a, 11b) of the hinge portion (10) has a substantially constant wall thickness which is essentially the same as the wall thickness of the peripheral wall (7).

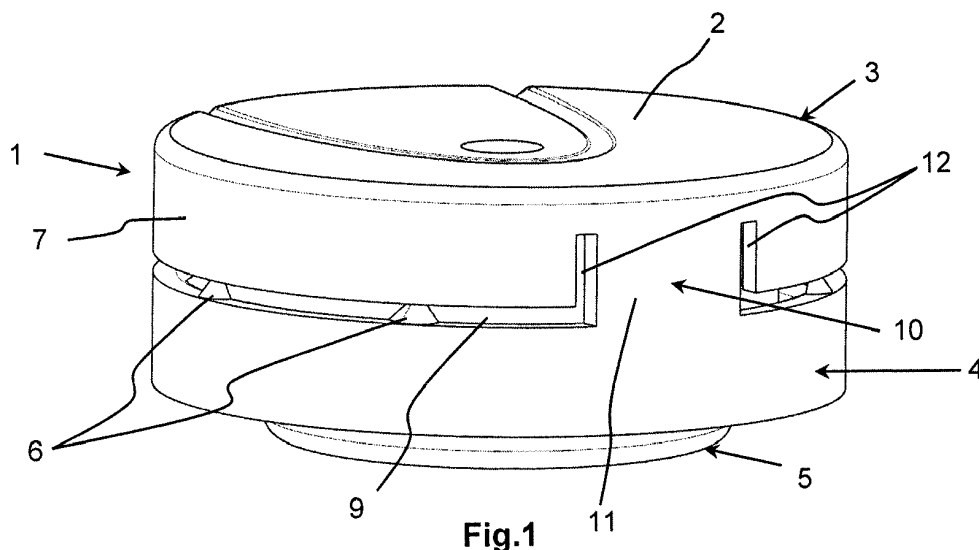

Fig.1

Description

Field of the Invention

[0001] The invention relates to a tamper-evident closure for the attachment to a container body, and a tamper-evident closure and container assembly for receiving loosely stored products, such as drugs, pills, tablets, test strips, granulate and even powder. Such containers should be moisture tight.

Technological Background

[0002] Closure caps for containers are known and common to the skilled person.

[0003] Often, flip-top closures are used for the attachment to sidewalls of a container which define an opening of the container.

[0004] Closures for containers are typically manufactured or moulded separately from the container body. The closures are then connected to the container body after the products to be stored, in particular pills, tablets or test strips have been introduced into the container body. The container body is typically a cylindrical tube having an opening at one end face and being closed at the opposite end face. After the loosely stored products have been introduced into the respective container body, the closure cap is attached to the container body.

[0005] Previously known closure caps may comprise a ring part which snaps over a bead around the opening of the container body and which connects the closure firmly to the container body by a positive lock.

[0006] The closure usually comprises a cap portion hinged to a ring part of the closure.

[0007] Generally, there are two basic types of hinges used.

[0008] A first basic possibility is the use of two-part hinges with two separate parts on the closure element and ring part, which can be snapped into each other and allow a relative rotation in order to open and close the cap element. An example of such hinge is given in US 2007/084735. Such hinges are disadvantageous in that they cannot be manufactured in one piece. Further, the axis of rotation usually radially exceeds the size of the cover part and the ring part.

[0009] A second basic concept uses a film hinge, for example as used in US 2008/0251573 A1.

[0010] Film hinges have a localized decrease in the thickness that function as a bending point for opening and closing of the container. Due to a largely reduced wall thickness of the film hinge connecting a cap portion to the ring part for attachment to the container body, the position of the pivot axis is well defined. However, film hinges are sometimes prone to breaking along the pivot line because the film part of the hinge easily breaks when the closure and container assembly inadvertently drops on a hard surface, or even in regular use after a high number of opening and closure movements.

[0011] US 2007/0272646 A1 discloses a relatively rigid hinge which is formed from two film hinges spaced from each other, making the connection between the cap element and the attachment ring rigid. Also in this type of hinge, the axis of rotation is well defined. Further, the hinge radially exceeds the size of the cover part and the ring part.

[0012] Another type of film hinge does not radially project beyond the size of the cover part and the ring part, but forms a depression on the outer surface of the ring part with a concave shape, for example as used in US 2011/062176. At the position where the wall thickness is smallest, there is the pivot axis of the hinge.

15 Summary of the Invention

[0013] It is the object of the invention to propose a tamper-evident closure for attachment to a tube which can be made in one piece and which has a robust hinge with a high endurance.

[0014] This object is solved by a tamper-evident closure for attachment to a container body with the features of claim 1, and a tamper-evident closure and container assembly with the features of claim 13. Preferred embodiments follow from the other claims.

[0015] According to the invention, a tamper-evident closure for the attachment to a container body comprises a cap portion comprising a top wall, a peripheral wall extending from the top wall, an attachment portion preferably aligned with the peripheral wall, a tamper proof means arranged and integrally formed between the cap portion and the attachment portion, and a hinge portion comprising at least one wall section which is integrally formed with the peripheral wall and the attachment portion and connects the cap portion and the attachment portion. Further, the at least one wall section of the hinge portion is formed between at least two cut outs, the at least one wall section of the hinge portion does not extend beyond an envelope defined by an outer surface of the peripheral wall and an outer surface of the attachment portion, and the at least one wall section of the hinge portion has a substantially constant wall thickness and in a horizontal plane section follows the outer curvature of the peripheral wall of the cap portion. Preferably, the wall thickness of the hinge portion is essentially the same as the wall thickness of the peripheral wall.

[0016] As used in this specification, geometrical terms like "top", "bottom", "vertical", "horizontal" and others relate to a tamper-evident closure and container assembly with closed cap standing upright on its bottom element on a horizontal surface. The separate tamper-evident closure for the attachment to such a container body is also described in such a position.

[0017] The inventive type of closure introduces a completely new concept. Since the at least one wall section of the hinge portion has a substantially constant wall thickness, there is no defined vertical position of the rotational axis provided by the hinge portion. Accordingly,

the closure according to the invention has no film hinge. Nevertheless, it is made in one piece in closed position. This is important in order to form a tamper-evident means. The hinge according to the present invention has the further advantage that it does not radially exceed the size of the cap portion and cover portion, nor is there a concave depression on the outer side in order to define the position of the rotational axis. According to the invention it is possible to provide a tamper-evident closure with a hinge portion, the wall section of which is essentially aligned with an outer surface of the peripheral wall extending downwardly from the top wall of the cap portion, and the attachment portion adjacent to the hinge portion. Accordingly, the inventive closure has a superior aesthetic appearance.

[0018] It is possible to design the closure such that no part of the closure extends beyond the outer dimensions of the container body. This makes it possible to densely pack a high number of closure and container assemblies together without the need to take care of any protruding parts between adjacent containers.

[0019] The inventive tamper-evident closure and container assembly for receiving loosely stored products comprises a container comprising a bottom element and at least one sidewall integrally formed with the bottom element at a lower end of the at least one sidewall and extending perpendicularly from the bottom element and forming an opening opposed to the bottom element. The at least one sidewall has an upper end to which a tamper-evident closure according to the invention is attached, for example by means of a rib formed on the sidewall of the container that interact with a corresponding part of the attachment portion of the closure.

[0020] A basic advantage of the inventive closure is that there is no longer a defined position of the axis of rotation. It is the at least one wall section of the hinge portion as such which deforms in order to allow the opening movement of the cap portion relative to the attachment portion. This reduces the high stresses suffered by the film hinges in the prior art and reduces the risk of an inadvertent breaking of the hinge leading to a higher endurance.

[0021] When using film hinges, there is a defined position with the highest strain. According to the invention, the strain does not concentrate in a small zone. This increases the endurance of the closure and the elasticity of the hinge is maintained over an extended period of time as compared to a film hinge made of the same material.

[0022] Further, the inventive closure is easier to manufacture using an injection moulding process. In order to provide the tamper-evident characteristics of the closure, it has to be moulded in the closed position. A film hinge with a small cross-sectional area impedes the flow of molten plastic material. In order to overcome this, a higher pressure has to be applied which, because of increased shear forces, also causes a temperature increase. The inventive closure with a substantially con-

stant wall thickness of the hinge portion between the attachment portion and the peripheral wall of the cap portion allows for an improved flow of material and reduces the moulding cycle time.

5 **[0023]** Another advantage of the inventive closure resides in the fact that the hinge allows to increase the distance between the moveable cap portion and the attachment portion, when the cap portion is opened. In such a way, an opening angle of more than 180°, even up to 10 270°, can be realized which improves the access to the products inside the container.

[0024] Finally, the opening and closing motions are not a rotational motion. Such complex opening and closing movements is advantageous when engaging or disengaging the sealing skirt with the sidewall of a container.

15 **[0025]** According to a preferred embodiment of the invention, the attachment portion is shaped to be attached to a tubular wall of a container body. This is the most frequently used geometry of the container bodies and the description of preferred embodiments will also focus 20 on a tubular wall of a container body. However, it should be appreciated that the tamper-evident closure according to the invention can also have a different shape and might be attached to e.g. a container body with a rectangular or ovoidal cross section.

25 **[0026]** According to a preferred embodiment of the invention, the at least two cut outs include an essentially U-shaped cut out delimiting a blocking portion extending downwards from the cap portion, said blocking portion being dimensioned to hold the cap portion in an opened position by interacting with at least one sidewall of the container body. The function of such blocking portion will be explained in more detail by reference to a specific embodiment of the invention. The provision and suitable 30 dimensioning of such blocking portion makes it possible to interact with the at least one sidewall of a corresponding container, once the closure has been attached to the container. The blocking portion acts like a deflectable tongue which is slightly deflected and slides over the top 35 of the sidewall of the container. In another embodiment, it slides over a supplemental bead provided on the upper part of the sidewall of the container. After that, the blocking portion snaps back into its relaxed position and forms a positive lock at the outer surface of the wall of the container. This keeps the cap portion in its open position until 40 a user closes the cap which again deflects the blocking portion in a radially outward direction followed by its movement over the top edge or the bead of the at least one sidewall of the container.

45 **[0027]** Preferably, the tamper-evident means comprises a plurality of frangible bridges between the peripheral wall of the cap portion and the attachment portion. Such structure is easy to manufacture in one piece and also contributes to an aesthetically pleasing appearance of 50 the closure because the peripheral wall of the cap portion and the attachment portion as well as the at least one wall section of the hinge portion can be provided such that their outer surfaces form one vertical straight surface

which is only interrupted by the at least two cut outs of the hinge portion and the slots between the frangible bridges of the tamper-evident means. Further, the provision of the frangible bridges at the side of the closure is easy to see so that a user will notice in case the closure has been opened before its intended first use.

[0028] As an alternative preferred embodiment, the tamper-evident means can comprise a tearable band between the cap portion and the attachment portion, preferably between the peripheral wall and the attachment portion. Also in this case, the closure can be provided with an aesthetically pleasing outer appearance and, at the same time, the tamper-evident means gives a clear indication to the user once the closure has been opened for the first time.

[0029] According to a preferred embodiment, the hinge portion consists of a single wall section which is formed between two cut outs, which are preferably vertical. In such a case, a single wall section forms the hinge element.

[0030] According to an alternative preferred embodiment, the hinge portion consists of two separate wall sections formed between vertical cut outs, respectively. In this case, there are two separate wall sections forming hinge elements. The provision of two separate wall sections can be advantageous in that the movement of the cap portion relative to the attachment portion is more defined because the two wall sections acting as a hinge are at a distance to each other.

[0031] In case of the preferred embodiment in which the hinge portion consists of two separate wall sections formed between vertical cut outs, a cut out between the two separate wall sections consists of an opening in the hinge portion, the width of the opening in a horizontal direction being preferably at least twice the width of the two individual separate wall sections. In this way, the two individual separate wall sections are provided sufficiently spaced from one another to provide for a defined opening movement and an even distribution of the bending forces between the two separate wall sections.

[0032] The cut outs can be provided in the peripheral wall of the cap portion and/or in the attachment portion. Preferably, the cut outs are formed in the peripheral wall of the cap portion because the holding of the attachment portion on a container is not impeded.

[0033] Preferably, the cover comprises a means for generating or maintaining a controlled atmosphere, preferably an adsorbent means. The adsorbent means can be a desiccant means, especially a desiccant chamber filled with a suitable desiccant material, like zeolites. Likewise, the adsorbent means can be provided with scavengers which reduce the oxygen contents inside the closed container.

[0034] In a preferred embodiment, the end sections of the cut outs are rounded. This avoids the formation at cracks at the position of sharp edges.

[0035] According to a preferred embodiment, the closure is integrally molded from plastic material, preferably

polyolefin based polymers.

[0036] Preferably, the cap portion comprises a sealing skirt being suitable to provide air-tightness when the cap portion is in a closed position. Such a sealing skirt of the cap portion is shaped and arranged so that, in a closed position of the cap portion on a corresponding container, it comes into sealing abutment with the at least one sidewall of the container close to its opening and prevents the ingress of air and especially moisture. Especially when the tamper-evident closure and container assembly is for receiving products like effervescent tablets, moisture sensitive drug products or diagnostic test strips, the provision of air-tightness is of high importance.

[0037] In order to further increase the tightness of the closure and container assembly, the peripheral wall can be arranged outside of the sealing skirt forming a gap of predetermined width between the sealing skirt and the outer wall. In such a way, a tight pressing contact between the at least one sidewall of the container and the sealing skirt is provided. Since the upper end of the at least on sidewall of the container enters the gap between the sealing skirt and the outer wall, it is fixed in this position in which the sealing skirt provides a sealing abutment to the inner surface of the at least one sidewall of the container.

[0038] Preferably, the container has one tubular sidewall.

[0039] In case that the container has one tubular sidewall and the hinge portion of the closure consists of a single wall section which is formed between two vertical cut outs, the distance between the two cut outs is preferably about 8% to 53% of the diameter of the cap portion. In other words, the angle between the two cuts is between 10° and 60°.

[0040] In another embodiment, the width of the hinge/the distance between the two cuts (not necessarily vertical) is sufficient to provide a spring effect to the hinge due to the curvature of the hinge portion.

Brief Description of the Drawings

[0041] In the following, specific embodiments of the invention will be described with reference to the drawings, in which:

Fig. 1 shows a perspective view of a first embodiment of a closure according to a first embodiment of the invention;

Fig. 2 shows a side view of the closure according to Fig. 1;

Fig. 3 is a cross-sectional view of the closure according to Fig. 1;

Fig. 4 shows a side view of a closure according to a second embodiment of the invention;

- Fig. 5 shows a closure in three dimensional view according to a third embodiment of the invention;
- Fig. 6 is a side view of the closure according to Fig. 5;
- Fig. 7 is a further side view of the closure according to Fig. 5 as shown from the side according to the paper plane of Fig. 6;
- Fig. 8 is a cross-sectional view of the closure according to the embodiment of Fig. 5;
- Fig. 9 is a cross-sectional view of the closure according to the line A-A of Fig. 7;
- Fig. 10 is a closure according to a fourth embodiment of the invention;
- Fig. 11 is a side view of the closure according to Fig. 10;
- Fig. 12 is a closure and container assembly exemplified by the embodiment of the closure according to Fig. 10;
- Fig. 13 is a cross-sectional view of the closure and container assembly according to Fig. 12;
- Fig. 14 shows another embodiment of the invention;
- Fig. 15 shows a three dimensional view of the closure according to another embodiment of the invention with a different tamper-evident means; and
- Figs. 16 and 17 are side views of the closure according to Fig. 15.

Description of Preferred Embodiments

[0042] Throughout the drawings, the same elements will be denoted by the same reference numerals.

[0043] In Fig. 1, a first embodiment of the invention is shown. The tamper-evident closure 1 as shown therein is a flip-top closure for attachment to a tube of a container. The tamper-evident flip-top closure 1 can be moulded in one piece from plastic material and generally comprises a cover part 3 which, as will be explained in more detail later, can provide for an air-tight sealing engagement with the tubular sidewall around the opening of a container. The cover part 3 has a top wall 2 and a peripheral wall 7

extending downwardly from the top wall 2 which is essentially horizontally arranged. Preferably, the peripheral wall 7 extends perpendicularly downwardly from the top wall and, therefore, extends in a vertical direction.

[0044] As outlined above, references to geometrical positions have to be understood in the context of a closure and container assembly with closed cover part 3 and with the container standing with its bottom on a horizontal surface.

[0045] In the different embodiments as shown, the top wall 2 is additionally provided with a tab which allows a user to grip the tab 8 in order to lift it up to open the cover part 3. The tab 8 does not extend beyond the periphery of the top wall of the cover part 3 (and beyond an envelope defined by an outer surface of the attachment portion 4). This tab 8 is provided by a brim above a recess formed by an interruption of the vertical peripheral wall 7 on the front of the cover part (see Fig. 12). Although such tab 8 is shown throughout the embodiments, it is not a limiting feature and the closure could be provided without a tab. Likewise, a tab could be provided which is displaceable into a position in which it protrudes beyond the periphery of the top wall so that it can be gripped. Such a displaceable tab further provides child resistance properties to the closure. Further, the tab could be provided at the peripheral wall 7.

[0046] The closure 1 is further provided with an attachment portion 4 for the attachment to a container. The attachment portion, once attached to the container, maintains its position relative to the container, whereas the cap portion 3 can be moved relative to the attachment portion when opening the cover part 3. The attachment portion comprises a ring part 4. The outer surface of the ring part 4 is aligned with the outer surface of the peripheral wall 7 of the cover part 3. The attachment portion also comprises a snap portion 41 on the inner surface of the ring part formed by a recess fitting to a corresponding rib 26 on the outer surface of the sidewall of the container.

[0047] Further, the closure is provided with a means for generating or maintaining a controlled atmosphere. Such means 5 can be an adsorption means. The adsorption means is a desiccant chamber formed by a cylindrical wall 54, in which a desiccant is provided, and closed by a permeable cardboard 56. The breathable cardboard 56 is conventionally attached to the wall of the desiccant chamber, here by means of heat for crimping the lower end of the wall of the desiccant chamber.

[0048] Between the ring part 4 and the peripheral wall, there are several frangible bridges 6 serving as a tamper proof means placed between the cover part 3 and the ring part 4. Upon first opening of the cover part 3, the frangible bridges 6 break as an indication that the closure has been opened. Between the frangible bridges, a gap 9 is formed which extends around most of the radial extension of the closure.

[0049] As can be seen in Fig. 1, the hinge portion 10 is formed by a wall section 11 which is integrally formed with the peripheral wall 7 and the ring part 4. The wall

section 11 of the hinge portion 10 is formed between two cut outs 12. The distance between the two cut outs 12 is preferably 8% to 53% of the outer diameter of the peripheral wall 7. The cut outs run essentially in a vertical direction and are essentially parallel to each other. The cut outs 12 start at the gap 9 and extend in an upwards direction towards the top wall 2 of the closure. Accordingly, the cut outs extend over a part of the height of the peripheral wall 7. The wall section 11 of the hinge portion 10 has the same wall thickness as the peripheral wall 7 and the ring part 4. Further, the wall section 11 of the hinge portion 10 does not extend beyond an envelope defined by an outer surface of the peripheral wall 7 and an outer surface of the ring part 4 of the attachment portion. Further, the wall thickness of the wall section 11 in a vertical section plane is constant. Accordingly, there is no pre-defined axis of rotation of the hinge portion 10.

[0050] The constant wall thickness of the wall section 11 can also be seen in the cross-sectional view of Fig. 3.

[0051] In Fig. 2, it can be seen that the wall section 11 is flush with the outer surface of the peripheral wall 7 and the ring part 4.

[0052] Turning now to Fig. 3 which is a cross-sectional view of the closure according to Fig. 1, it can be seen that the wall section 11 of the hinge portion does not extend beyond an envelope defined by an outer surface of the peripheral wall 7 and an outer surface of the attachment portion 4. Further, it can be seen that there is no defined weakening of the wall section 11 forming a hinge portion. Instead, the whole wall section 11 serves as the hinge without a defined axis of rotation. Further it can be seen in Fig. 8, that there is a chamber 52 inside the adsorption means 5 for receiving an adsorbent material.

[0053] The embodiment of Fig. 4 is identical to that as described with reference to Figs. 1 to 4 except for the shape of the cut outs 12 which generate a wall section 11 of varying length in a circumferential direction of the closure. At the position with the smallest length, there is the preferred position of the wall section 11 which will bend most when the cap portion will be opened.

[0054] Turning now to Figs. 5 to 9, a further embodiment of the invention is shown. The embodiment is identical to that as shown in Figs. 1 to 3 except for the geometry of the hinge portion 10. Accordingly, the description of the other elements is omitted and reference can be made to the description of the embodiment as shown in Figs. 1 to 3.

[0055] As can be seen in Fig. 5, the hinge portion comprises two wall sections 11a and 11b. Further, there is an opening 13 in the hinge portion acting as a common cut out between the wall sections 11a, 11b. The cut outs 12 are similar to those as shown in the first embodiment according to Figs. 1 to 3. In other words, the first wall section 11a is formed between the first cut out 12 starting from gap 9 and the opening 13 in the hinge portion 10. The wall section 11b of the hinge portion is formed between the second cut out 12 also starting from the gap

9 and the opening 13 in the hinge portion. The width of the opening 13 in a horizontal direction is at least twice the width of the two individual separate wall sections 11a, 11b.

[0056] In this embodiment, the provision of two separate wall sections 11, 11b of the hinge portion which are at a distance to each other being at least twice the individual width of each wall section provides for a well-defined opening movement of the cover part when opening the closure 1.

[0057] Like in the embodiment according to Figs. 1 to 3, the two wall sections 11a, 11b have a constant wall thickness when considered in a vertical section plane. The wall thickness corresponds to the wall thickness of the peripheral wall 7 as well as the ring part 4. Further, the outer surface of the wall sections 11a, 11b, the peripheral wall 7 in the region of the hinge and the ring part in the region of the hinge are flush with each other such that an envelope defined by an outer surface of the peripheral wall, the ring part and the wall sections is a curved plane with a curvature only in a horizontal direction, whereas the vertical direction of the envelope is straight.

[0058] From Fig. 9, which is a cross-sectional view according to A-A in Fig. 7, it can be derived that the wall sections 11a, 11b are arranged so as to form an angle α between their remotest positions. The angle α preferably ranges from 10° to 60°.

[0059] With regard to the other aspects, the embodiment according to Figs. 5 to 9 is identical to that which was explained with reference to Figs. 1 to 3.

[0060] Figs. 10 to 13 show a further embodiment of the invention. Again, it distinguishes from the above-described embodiments only with respect to the geometry of the hinge section such that the description of the other parts can be omitted and reference can be made to the detailed description of the embodiment of Figs. 1 to 3.

[0061] The embodiment according to Fig. 10 is similar to that as shown in Fig. 5 in that the hinge portion comprises two wall sections 11a and 11b. However, there is a difference in that the cut outs 12 starting from the gap 9 between the peripheral wall 7 and the ring part 4 do not extend vertically upwards from the gap 9 into the wall of the peripheral wall 7, but extend in a downwards direction starting from gap 9. In other words, the cut outs 12 extend into the wall of the ring part 4.

[0062] Instead of the opening 13 according to the embodiment of Figs. 4 to 7, a U-shaped cut out 14 is provided. The U-shaped cut out 14 is formed such that the basis 15 of the "U" is horizontally arranged essentially at the lower end of the cut outs 12, whereas the two side pieces 16 of the "U" extend vertically upwards from the basis 15 of the "U" and vertically upwards therefrom. As a result of this, the first wall section 11a is formed between cut out 12 and the adjacent side pieces 16 of the U-shaped cut out 14, whereas the second wall section 11b is formed between its adjacent cut out 12 and the adjacent, second side piece 16 of the U-shaped cut out 14. Also in this embodiment, the two wall sections 11a, 11b

form hinges identical to that as explained in more detail with reference to Figs. 5 to 9.

[0063] In contrast to the embodiment as shown in Figs. 5 to 9, there is no opening 13 of an essential rectangular shape in the hinge portion, but a blocking portion 18 which is integrally formed with the peripheral wall 7 and depends downwardly from the peripheral wall 7. The blocking portion 18 is surrounded by the U-shaped cut out 14. The blocking portion has the function to cooperate, once the closure 1 according to the embodiment of Figs. 8 and 9 has been attached to a container body, as a means for maintaining the cover part 3 of the closure in an open position.

[0064] A closure and container assembly is shown in Fig. 12. The container 20 has a sidewall 22 which is integrally formed with the bottom element 24. The tubular sidewall 22 extends perpendicularly from the bottom element 24 and forms an opening 26 opposed to the bottom element 24. The tamper-evident closure is attached to the sidewall 22 close to the opening 26 and is held in place by a rib 28 on the sidewall 22 (best shown in Fig. 13). Further, the closure according to this embodiment of the invention is also provided with a receiving structure for a means 5 for generating or maintaining a controlled atmosphere. It can be a conventional stopper element which is provided with desiccant but also other types of active agent like oxygen scavengers are contemplated.

[0065] When the closure according to Figs. 10 and 11 is attached to the body of the container, and the cover part 3 is opened into the position as shown in Fig. 12 and 13, the cover part 3 is kept in the opened position. This is achieved by means of the blocking portion 18 which extends downwards from the cover part 3 and is dimensioned and shaped such that it holds the cover part 3 in an opened position by interacting with the upper end of the sidewall 22 of the container body. To this end, the blocking portion 18 is dimensioned such that it slightly bends in a radially inwards direction during the opening of the cover part 3. When bent in an inwards direction, the blocking portion 18 can slip over the upper end of the sidewall 22. When further pivoting the cover part 3, the blocking portion 18 snaps back into its relaxed position and form a form lock by extending over the outer surface of the sidewall of the container body. Since a certain bending force acting on the blocking portion 18 is required to close the cover part 3 again, the cover part 3 is kept in the opened position and does not fall back into the closed position even in case that a means 5 for generating or maintaining a controlled atmosphere is provided with a certain weight. Accordingly, the blocking portion 18 serves for further convenience to a user of the closure and container assembly.

[0066] Figs. 15 to 17 show another embodiment similar to that according to Figs. 10 and 11. The only difference lies in the provision of a tear band 67 as a tamper-evident means. The tear band 67 is provided with an extension 68 to conveniently grip and remove the band when opening the container for the first time.

[0067] The inventive closure and closure and container assembly has the advantage that the closure can be made in one piece and comprises a hinge that is an alternative to the previously known hinges. It can be manufactured in one piece in closed position in order to include the tamper-evident means and is provided with a hinge without a considerable weakening of the material and without a pre-defined position of the rotational axis. In such a way, the hinge will not easily become worn-out and is less prone to breaking.

[0068] In all embodiments of the invention, provisions can be made to provide an air-tight sealing of the cover part 3 on the container. Such sealing can be effected either by means of a single sealing structure using a sealing skirt providing air-tightness of the container when the cover is in the closed position. The sealing skirt 32 can be best seen in the cross-sectional views of Figs. 3 and 8. It is provided with an outwardly protruding, convex projection 34 which serves to abut against the inner surface of the sidewall 22 when the closure 1 is correctly positioned on top of the sidewall of the container body. Such structure provides a sealing contact surface consisting a small contact surface formed by the apex of the convex projection 34 in contact with the inner circumferential surface of the sidewall 22. Such small contact surface has superior sealing properties because the deformation of the convex projection compensates surface irregularities. Such sealing structure with one sealing element or two cooperating sealing elements can be provided in all embodiments as described above, but also together with a closure and container assembly of a different geometry, e.g. with a plurality of sidewalls and of a rectangular cross-sectional shape.

Claims

1. A tamper-evident closure for the attachment to a container body, comprising:
 - a cap portion (3) comprising a top wall (2) and a peripheral wall (7) extending downwardly from the top wall (2); the cap portion (3) preferably forming a flip-top closure (1);
 - an attachment portion (4) preferably aligned with the peripheral wall (7);
 - a tamper-proof means (6) arranged and integrally formed between the cap portion (3) and the attachment portion (4); and
 - a hinge portion (10) comprising at least one wall section (11; 11a, 11b) which is integrally formed with the peripheral wall (7) and the attachment portion (4) and connects the cap portion (3) and the attachment portion (4); wherein
 - the at least one wall section (11; 11a, 11b) of the hinge portion (10) is formed between at least two cut outs (12; 12, 13; 12, 14);
 - the at least one wall section (11; 11a, 11b) of

- the hinge portion (10) does not extend beyond an envelope defined by an outer surface of the peripheral wall (7) and an outer surface of the attachment portion (4); and
- the at least one wall section (11; 11a, 11b) of the hinge portion (10) has a substantially constant wall thickness and in a horizontal plane section follows the outer curvature of the peripheral wall (7) of the cap portion (3), wherein the substantially constant wall thickness is preferably essentially the same as the wall thickness of the peripheral wall (7).
2. Tamper-evident closure according to claim 1, wherein the attachment portion (4) is shaped to be attached to a tubular wall (22) of a container body (20).
 3. Tamper-evident closure according to claim 1 or 2, wherein the at least two cut outs include an essentially U-shaped cut out (14) delimiting a blocking portion (18) extending downwards from the cap portion (3), said blocking portion (18) being dimensioned to hold the cap portion (3) in an opened position by interacting with the at least one sidewall (22) of a corresponding container body (20).
 4. Tamper-evident closure according to any of the preceding claims, wherein the tamper-evident means (6) comprises a plurality of frangible bridges between the peripheral wall (7) of the cap portion (3) and the attachment portion.
 5. Tamper-evident closure according to any of the claims 1 to 3, wherein the tamper-evident means (6) comprises a tearable band (67) between the cap portion (3) and the attachment portion (4), preferably between the peripheral wall (7) and the attachment portion (4).
 6. Tamper-evident closure according to any of the preceding claims, wherein the hinge portion (10) consists of a single wall section (11) which is formed between two vertical cut outs (12).
 7. Tamper-evident closure according to any of the claims 1 to 5, wherein the hinge portion consists of two separate wall sections (11a, 11b) formed between vertical cut outs (12, 13; 12, 14).
 8. Tamper-evident closure according to claim 7, wherein a cut out (13) between the two separate wall sections (11a, 11b) consists of an opening (13) in the hinge portion (10), the width of the opening (13) in a horizontal direction having preferably at least twice the width of the two individual separate wall sections (11a, 11b).
 9. Tamper-evident closure according to any of the preceding claims, wherein the cover comprises a means (5) for generating or maintaining a controlled atmosphere, preferably an adsorbent means (5).
 10. Tamper-evident closure according to any of the preceding claims and being integrally moulded from plastic material, preferably polyolefin based polymers.
 11. Tamper-evident closure according to any of the preceding claims, wherein the cap portion (3) comprises a sealing skirt (32) being suitable to provide air-tightness when the cap portion (3) is in a closed position.
 12. Tamper-evident closure according to any of the preceding claims, **characterized in that** the peripheral wall (7) is an outer wall which is arranged outside of the sealing skirt (32) forming a gap of predetermined width between the sealing skirt (32) and the outer wall (7).
 13. Tamper-evident closure and container assembly for receiving loosely stored products, comprising:
 - a container (20) comprising
 - a bottom element (24); and
 - at least one sidewall (22) integrally formed with the bottom element (24) at a lower end of the at least one sidewall (22) and extending perpendicularly from the bottom element (24), and forming an opening (26) opposed to the bottom element (24);
 - the at least one sidewall (22) having an upper end to which a tamper-evident closure (1) according to any of the preceding claims is attached and closes the opening (26) of the container (20) in an air-tight manner.
 14. Tamper-evident closure and container assembly according to claim 13, the container having one tubular sidewall (22).
 15. Tamper-evident closure and container assembly according to claim 14, with a closure according to claim 11, wherein the sealing skirt (32) cooperates with an inner surface of the sidewall (22) of the container (20).

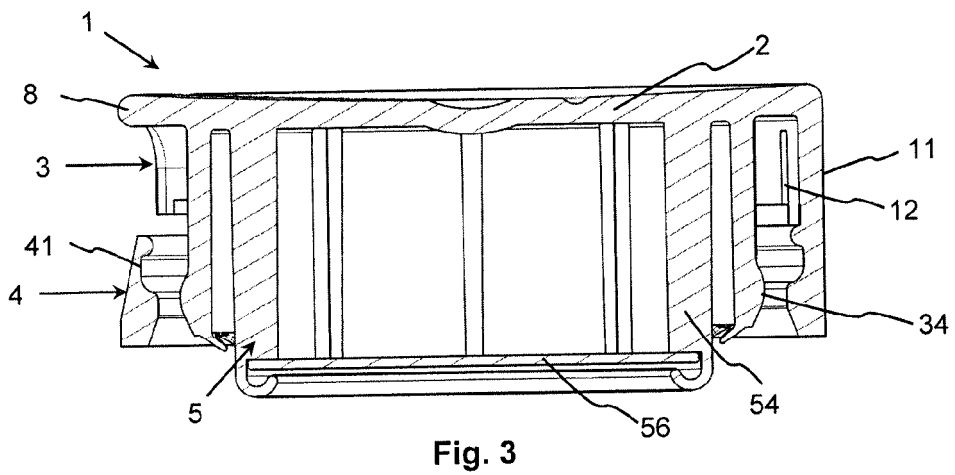
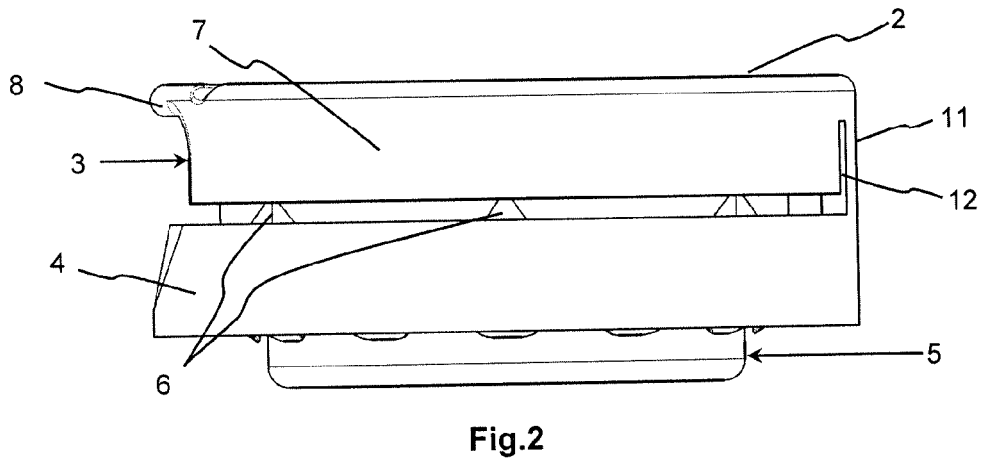
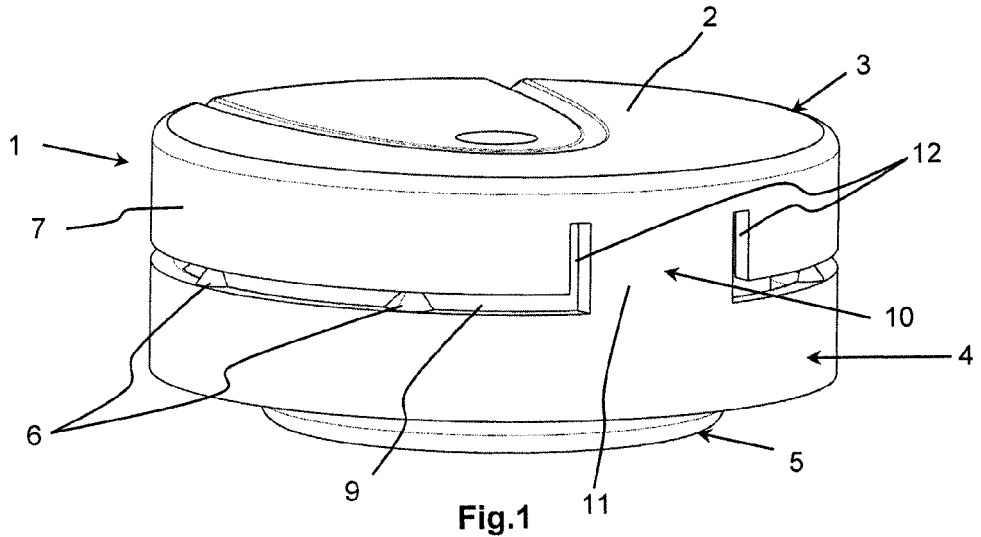

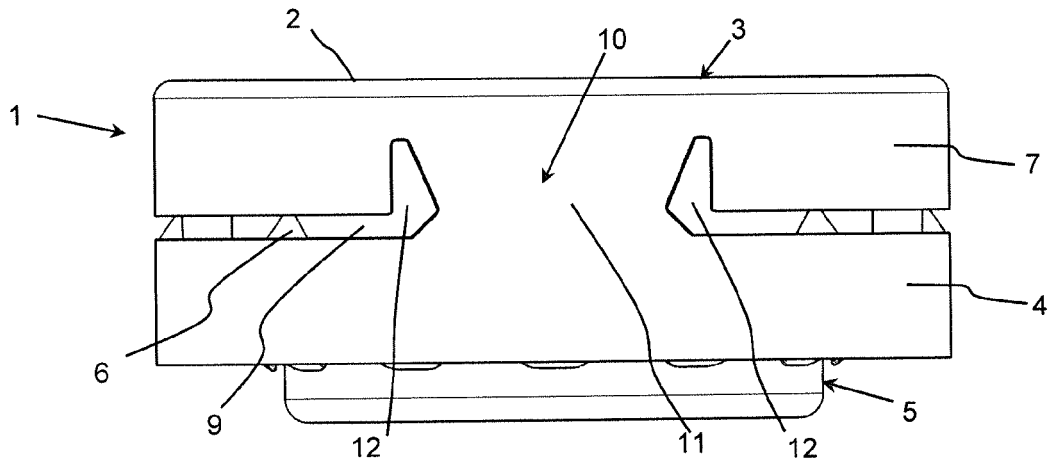

Fig. 4

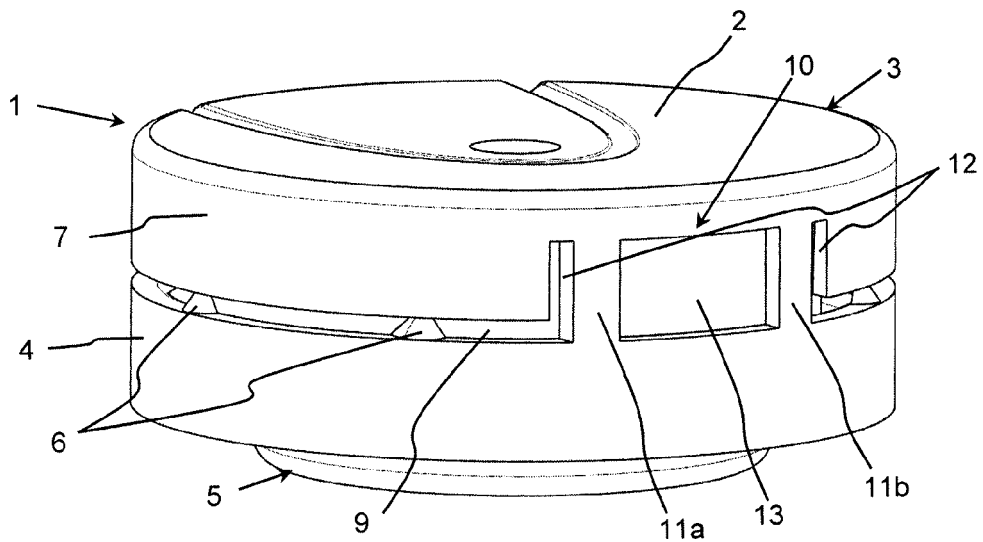

Fig. 5

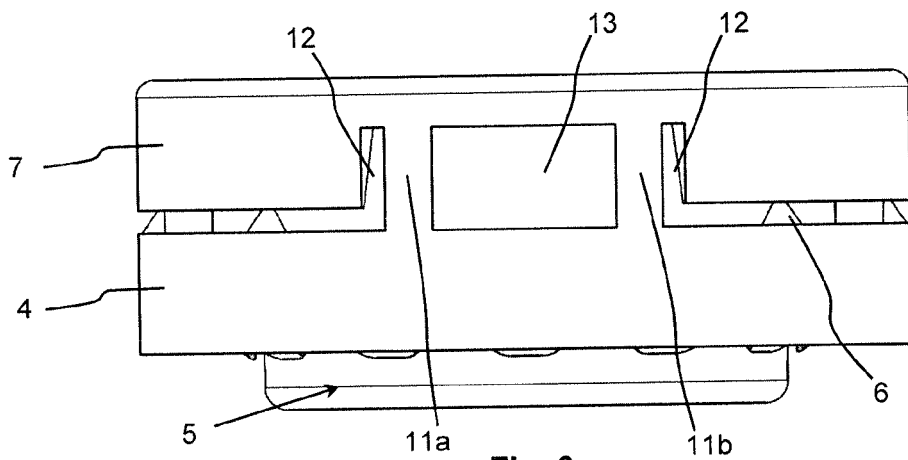

Fig. 6

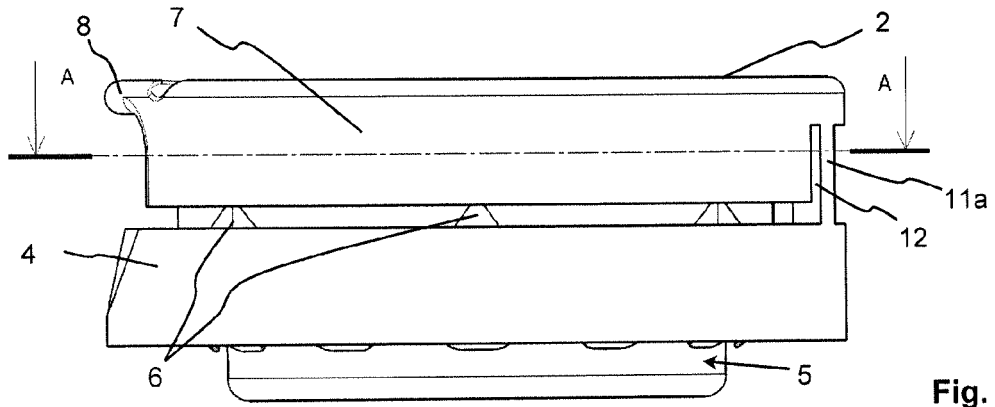

Fig. 7

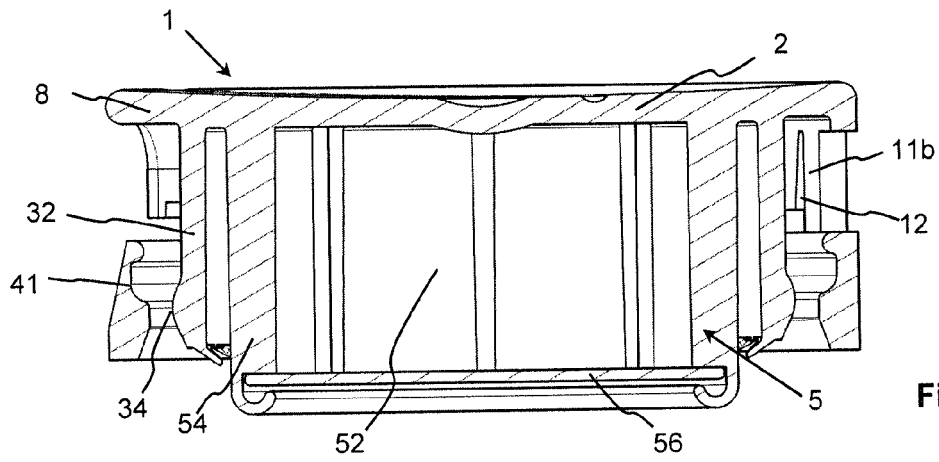

Fig. 8

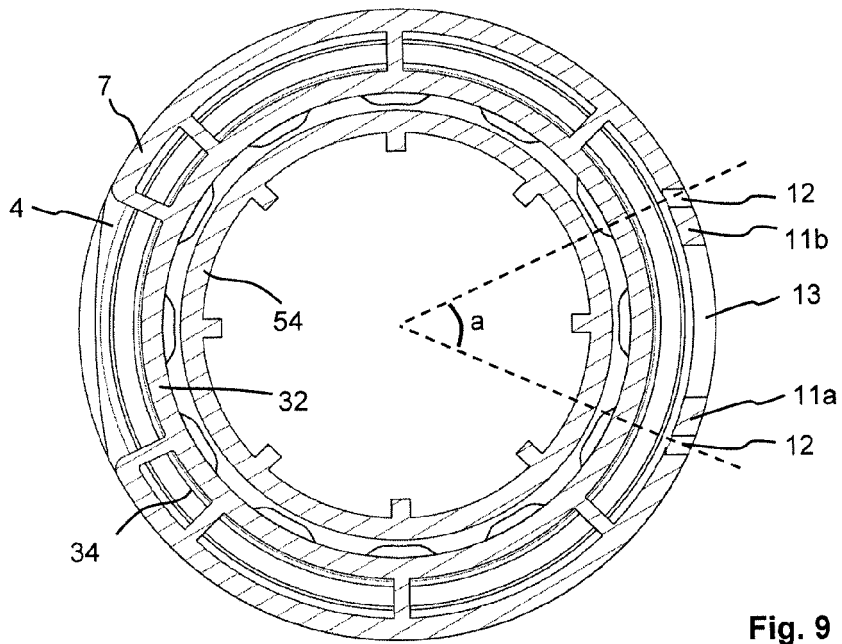
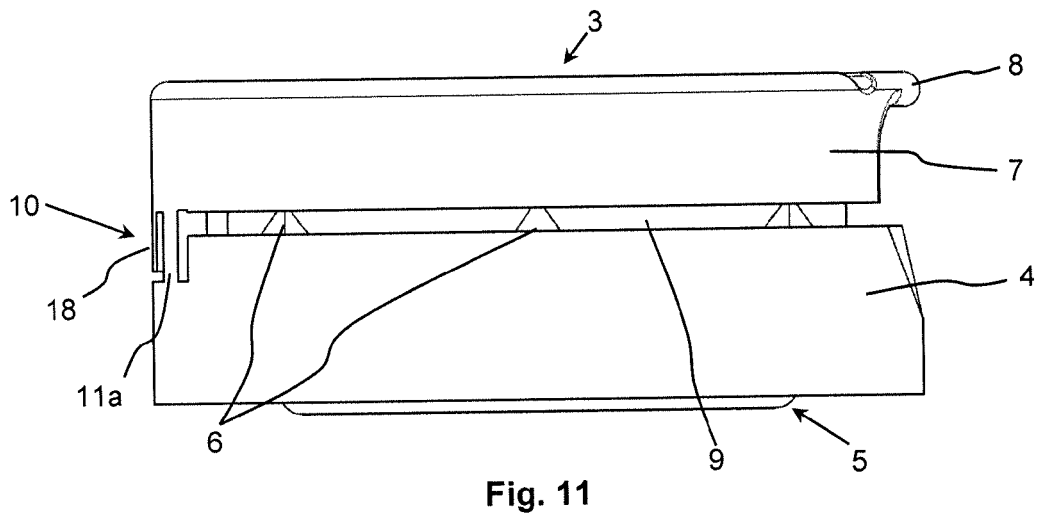
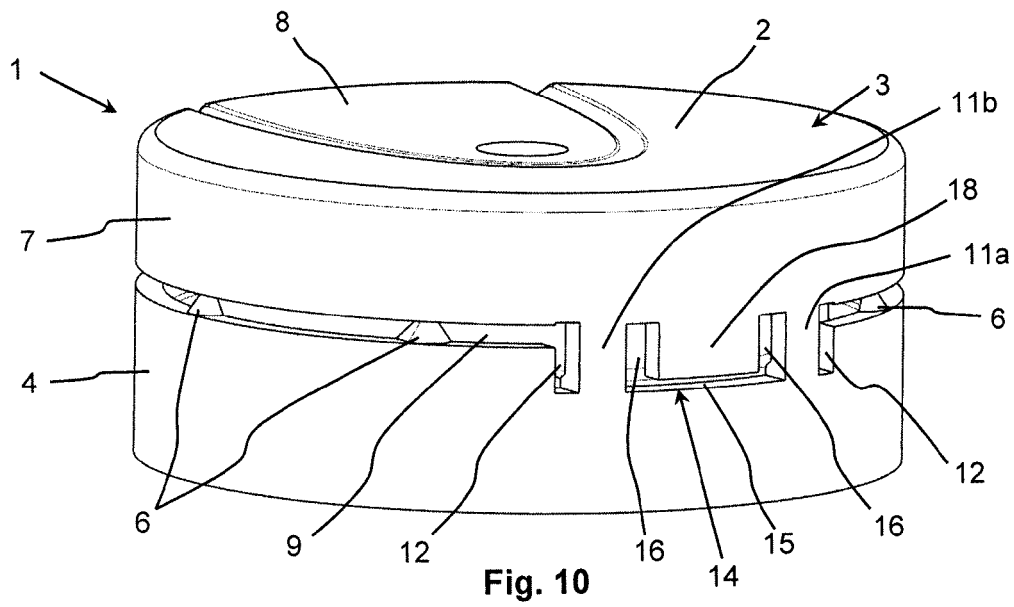

Fig. 9



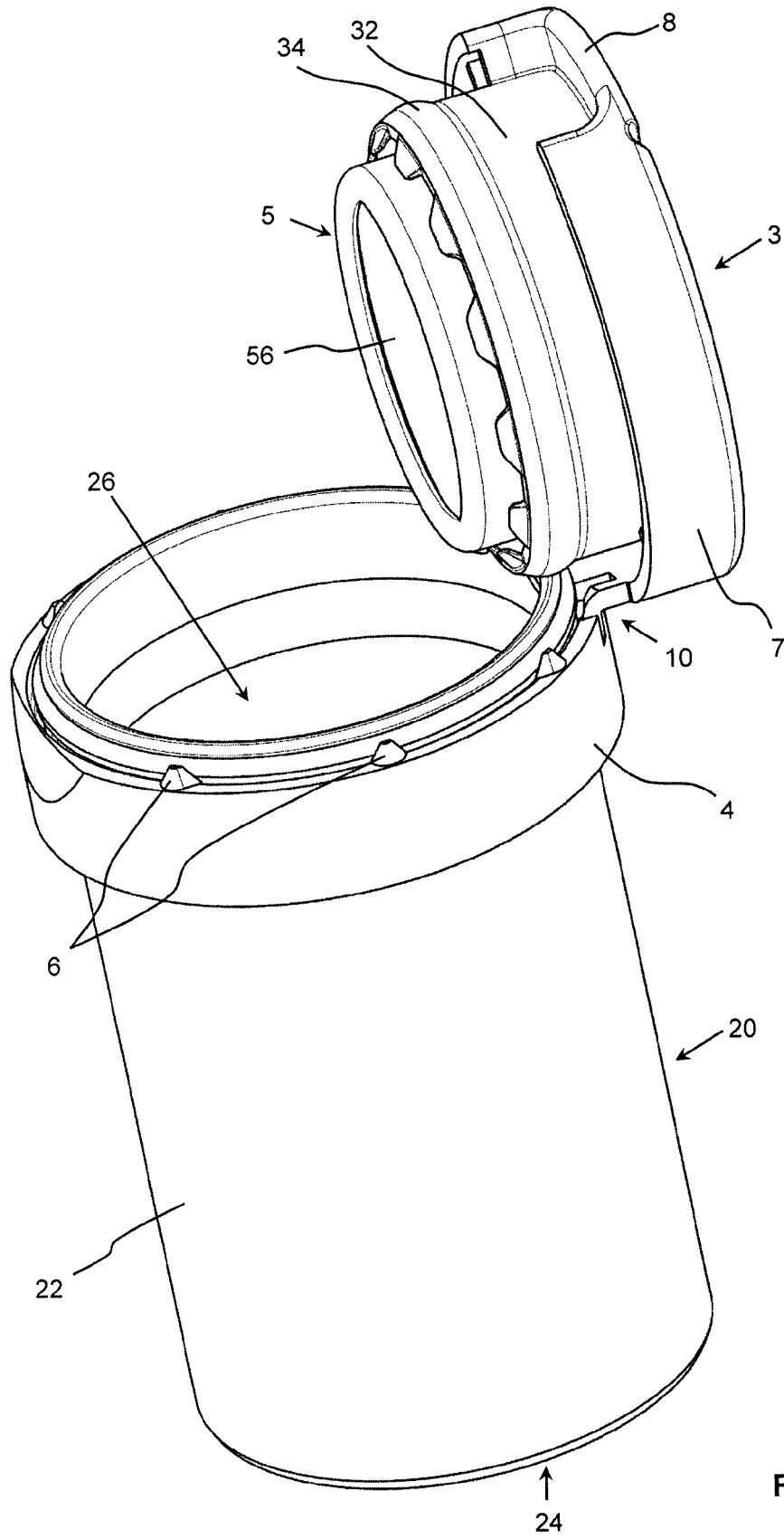

Fig. 12

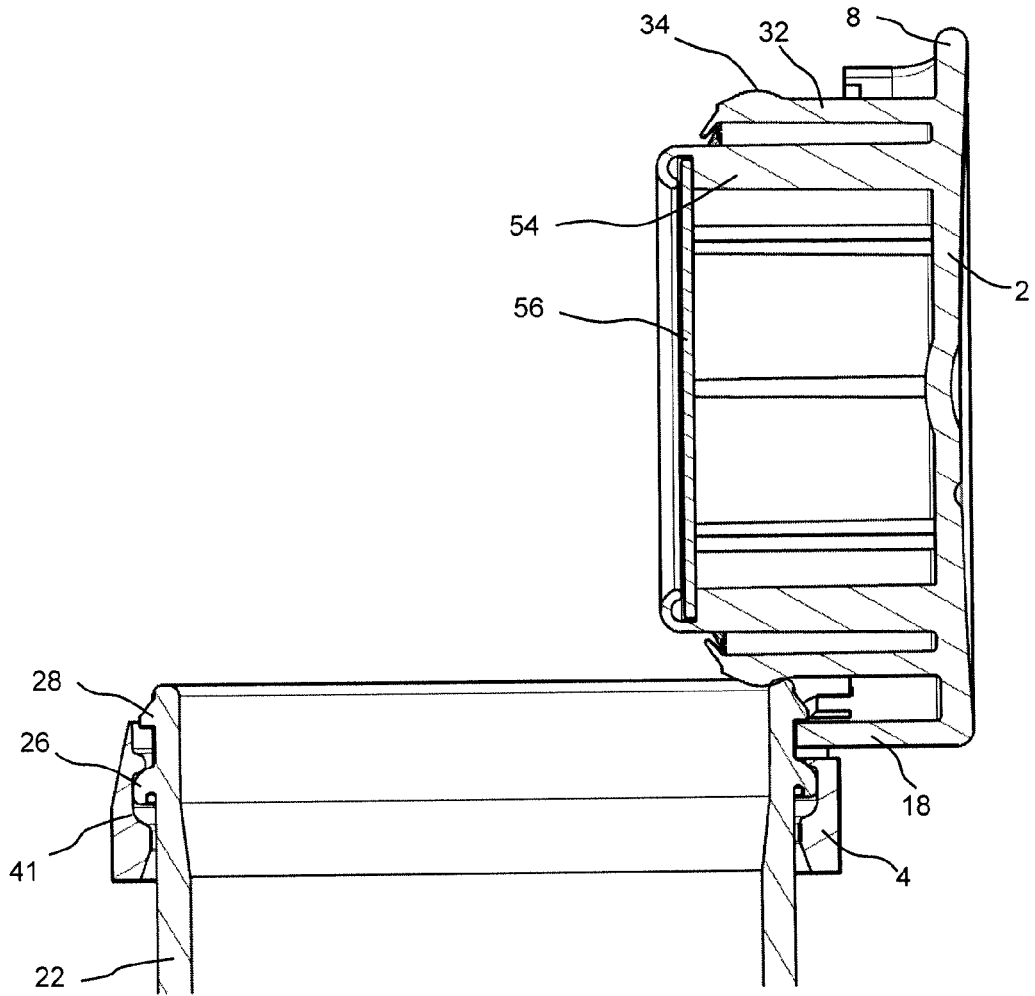

Fig. 13

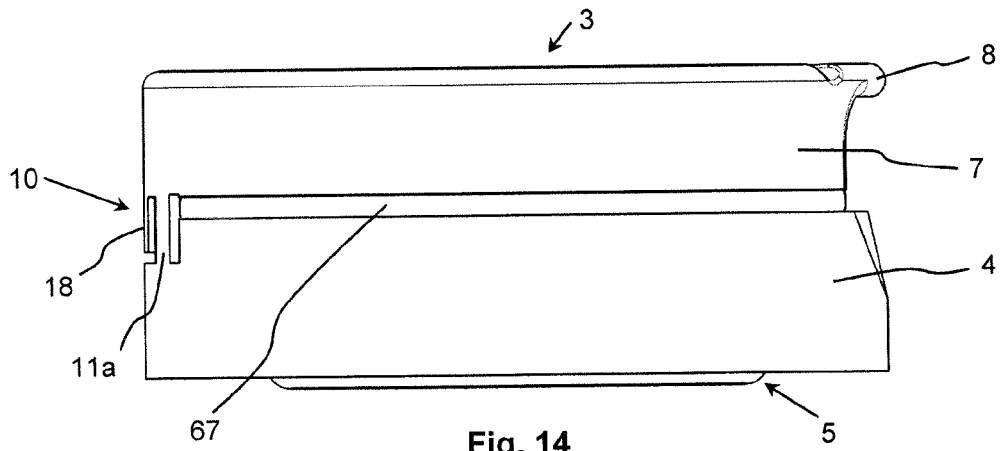

Fig. 14

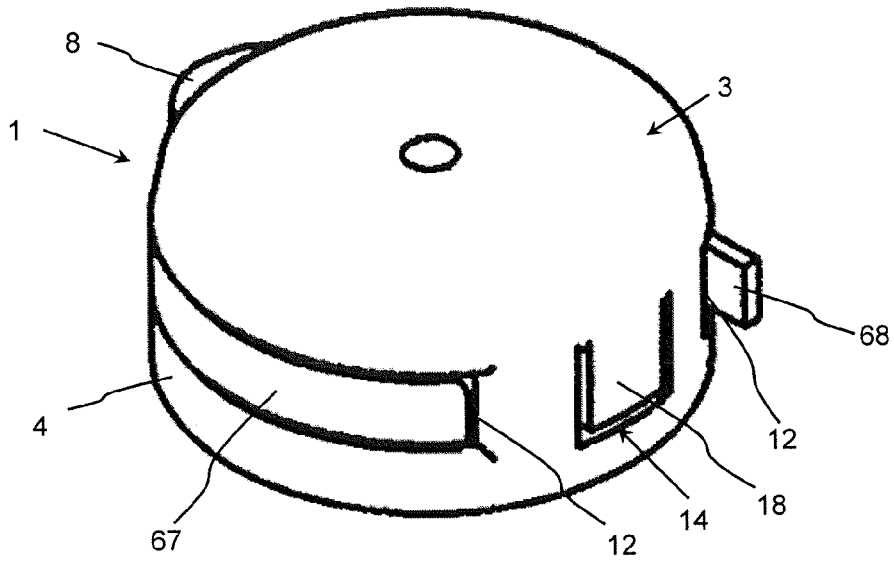

Fig. 15

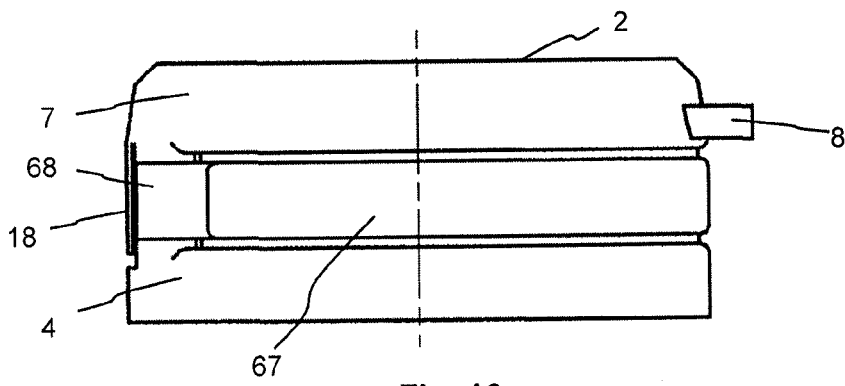

Fig. 16

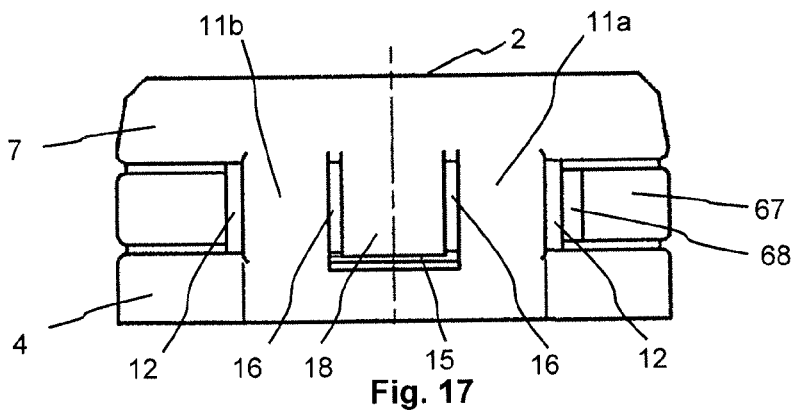

Fig. 17



EUROPEAN SEARCH REPORT

Application Number
EP 15 30 5573

5

10

15

20

25

30

35

40

45

50

55

DOCUMENTS CONSIDERED TO BE RELEVANT			
Category	Citation of document with indication, where appropriate, of relevant passages	Relevant to claim	CLASSIFICATION OF THE APPLICATION (IPC)
X	US 2005/115968 A1 (MYHRE SVEIN [NO]) 2 June 2005 (2005-06-02)	1,2,4, 10,11, 13,14	INV. B65D47/08 B65D51/30
Y	* the whole document *	9,12	
X	US 5 605 240 A (GUGLIELMINI BERNARD [FR]) 25 February 1997 (1997-02-25) * the whole document *	1,2,5,6, 13-15	
Y	US 2007/272646 A1 (LANCESSEUR DIDIER [FR] ET AL) 29 November 2007 (2007-11-29) * the whole document *	9,12	
A	* the whole document *	1,13	
A	WO 2005/007526 A1 (CREANOVA AG [CH]; LAGLER LOUIS [CH]) 27 January 2005 (2005-01-27) * the whole document *	1-15	
A	WO 2009/138128 A1 (AIRSEC SAS [FR]; LOURENCO ARMINDO [FR]; SEBILLE VINCENT [FR]) 19 November 2009 (2009-11-19) * the whole document *	1-15	TECHNICAL FIELDS SEARCHED (IPC)
A	WO 2011/039400 A1 (GOIPLASTIK S L [ES]; BERNAL ARDANAZ FRANCISCO JAVIER [ES]; GARCIA ALBO) 7 April 2011 (2011-04-07) * the whole document *	1-15	B65D
The present search report has been drawn up for all claims			
Place of search The Hague		Date of completion of the search 12 October 2015	Examiner Pernice, Ciro
CATEGORY OF CITED DOCUMENTS X : particularly relevant if taken alone Y : particularly relevant if combined with another document of the same category A : technological background O : non-written disclosure P : intermediate document		T : theory or principle underlying the invention E : earlier patent document, but published on, or after the filing date D : document cited in the application L : document cited for other reasons & : member of the same patent family, corresponding document	

1
EPO FORM 1503 03.02 (P04C01)

ANNEX TO THE EUROPEAN SEARCH REPORT
ON EUROPEAN PATENT APPLICATION NO.

EP 15 30 5573

5 This annex lists the patent family members relating to the patent documents cited in the above-mentioned European search report.
The members are as contained in the European Patent Office EDP file on
The European Patent Office is in no way liable for these particulars which are merely given for the purpose of information.

12-10-2015

Patent document cited in search report	Publication date	Patent family member(s)	Publication date
US 2005115968 A1	02-06-2005	AT 345281 T	15-12-2006
		AU 2003202172 A1	30-07-2003
		CA 2472221 A1	24-07-2003
		DE 60309663 T2	11-10-2007
		EP 1465813 A1	13-10-2004
		ES 2277057 T3	01-07-2007
		JP 2005514286 A	19-05-2005
		US 2005115968 A1	02-06-2005
		WO 03059772 A1	24-07-2003
US 5605240 A	25-02-1997	AT 159908 T	15-11-1997
		AU 693862 B2	09-07-1998
		AU 1789895 A	16-11-1995
		BR 9501910 A	28-11-1995
		CA 2148781 A1	07-11-1995
		DE 69500972 D1	11-12-1997
		DE 69500972 T2	05-03-1998
		DK 0680887 T3	22-12-1997
		EP 0680887 A1	08-11-1995
		ES 2109056 T3	01-01-1998
		FR 2719559 A1	10-11-1995
		GR 3025814 T3	31-03-1998
		HU 218868 B	28-12-2000
		PL 308452 A1	13-11-1995
		US 5605240 A	25-02-1997
US 2007272646 A1	29-11-2007	AT 440785 T	15-09-2009
		EP 1704099 A1	27-09-2006
		EP 2119637 A1	18-11-2009
		FR 2863968 A1	24-06-2005
		US 2007272646 A1	29-11-2007
		WO 2005061343 A1	07-07-2005
WO 2005007526 A1	27-01-2005	AT 377562 T	15-11-2007
		AU 2003304342 A1	04-02-2005
		BR 0318407 A	01-08-2006
		CA 2532214 A1	27-01-2005
		CN 1802292 A	12-07-2006
		DE 60317377 T2	20-05-2009
		DK 1648792 T3	28-01-2008
		EP 1648792 A1	26-04-2006
		EP 1889791 A1	20-02-2008
		ES 2292989 T3	16-03-2008
		HK 1098993 A1	17-04-2009
		IL 172810 A	17-05-2010
		JP 4963833 B2	27-06-2012

EPO FORM P0459

For more details about this annex : see Official Journal of the European Patent Office, No. 12/82

ANNEX TO THE EUROPEAN SEARCH REPORT
ON EUROPEAN PATENT APPLICATION NO.

EP 15 30 5573

5 This annex lists the patent family members relating to the patent documents cited in the above-mentioned European search report.
The members are as contained in the European Patent Office EDP file on
The European Patent Office is in no way liable for these particulars which are merely given for the purpose of information.

12-10-2015

Patent document cited in search report	Publication date	Patent family member(s)	Publication date
		JP 2007505008 A	08-03-2007
		NZ 544794 A	30-11-2007
		PT 1648792 E	17-01-2008
		UA 82383 C2	10-04-2008
		US 2006163188 A1	27-07-2006
		US 2014197189 A1	17-07-2014
		WO 2005007526 A1	27-01-2005

WO 2009138128 A1	19-11-2009	EP 2307282 A1	13-04-2011
		US 2011062176 A1	17-03-2011
		WO 2009138128 A1	19-11-2009

WO 2011039400 A1	07-04-2011	ES 1071297 U	11-02-2010
		WO 2011039400 A1	07-04-2011

REFERENCES CITED IN THE DESCRIPTION

This list of references cited by the applicant is for the reader's convenience only. It does not form part of the European patent document. Even though great care has been taken in compiling the references, errors or omissions cannot be excluded and the EPO disclaims all liability in this regard.

Patent documents cited in the description

- US 2007084735 A [0008]
- US 20080251573 A1 [0009]
- US 20070272646 A1 [0011]
- US 2011062176 A [0012]