

(19)



(11)

**EP 3 090 656 B1**

(12)

**EUROPEAN PATENT SPECIFICATION**

(45) Date of publication and mention  
of the grant of the patent:  
**23.05.2018 Bulletin 2018/21**

(51) Int Cl.:  
**A47C 1/03 (2006.01)**

(21) Application number: **16167967.5**

(22) Date of filing: **02.05.2016**

(54) **ARMREST, IN PARTICULAR FOR OFFICE CHAIRS**

ARMLEHNE, INSBESONDERE FÜR BÜROSTÜHLE

ACCOUDOIR, EN PARTICULIER POUR DES CHAISES DE BUREAU

(84) Designated Contracting States:  
**AL AT BE BG CH CY CZ DE DK EE ES FI FR GB  
GR HR HU IE IS IT LI LT LU LV MC MK MT NL NO  
PL PT RO RS SE SI SK SM TR**

(30) Priority: **05.05.2015 IT VE20150021**

(43) Date of publication of application:  
**09.11.2016 Bulletin 2016/45**

(73) Proprietor: **Brado S.p.A.  
31030 Valdobbiadene (IT)**

(72) Inventor: **Serena, Stefano  
31030 Valdobbiadene (IT)**

(74) Representative: **Piovesana, Paolo  
Via F. Baracca, 5/a  
30173 Venezia-Mestre (IT)**

(56) References cited:  
**CN-U- 201 948 441 US-A1- 2005 093 358  
US-B1- 6 837 545**

**EP 3 090 656 B1**

Note: Within nine months of the publication of the mention of the grant of the European patent in the European Patent Bulletin, any person may give notice to the European Patent Office of opposition to that patent, in accordance with the Implementing Regulations. Notice of opposition shall not be deemed to have been filed until the opposition fee has been paid. (Art. 99(1) European Patent Convention).

## Description

**[0001]** The present invention relates to an armrest, in particular for office chairs.

**[0002]** Armrests are known consisting of a substantially L-shaped support bracket, with the end of the horizontal arm connected to the support structure of the chair seating portion and with the upper end of the vertical arm connected to a pad on which the user's arm rests.

**[0003]** These known armrests are generally provided with an element for adjusting the position of the top of the pad relative to the upper surface of the seating portion, to satisfy the most varied ergonomic requirements of the user.

**[0004]** These known armrests present however the drawback of consisting of an assemblage of a large number of small metal and plastic parts with the inconvenience of having to use tools and specialized labour for their assembly.

**[0005]** CN 2011 948 441 U describes an armrest provided with a pushbutton 90 having one end engaged in the lateral surface of the sleeve and the other end provided with an appendix selectively engagable with one of the teeth of a rack provided in an L-shaped bracket. A coil spring 84 maintains the end of the pushbutton 90 engaged in the rack and returns it to this configuration when pressed to adjust the tube height.

**[0006]** An object of the invention is to eliminate all these drawbacks by providing an armrest which can be assembled rapidly without the use of tools.

**[0007]** This object is attained according to the invention by an armrest, in particular for office chairs, as described in claim 1.

**[0008]** The present invention is further clarified hereinafter with reference to the accompanying drawings, in which:

Figure 1 is an exploded perspective view showing an armrest according to the invention,

Figure 2 is a perspective view thereof seen from below,

Figure 3 is a partial longitudinal section therethrough in the configuration in which the armrest is locked,

Figure 4 is a cross-section therethrough,

Figure 5 shows it in the same view as Figure 3, but in the configuration in which the armrest is released,

Figure 6 is a cross-section therethrough,

Figure 7 is an exploded perspective partial view showing a modified embodiment of a bracket, and

Figure 8 shows this latter assembled.

**[0009]** As can be seen from the figures, the armrest according to the invention is made of plastic material and comprises an L-shaped bracket 2 with its vertical part 4 of rectangular cross-section and its horizontal part 6 en-

gagable in the support structure of the seating portion.

**[0010]** A plurality of horizontal parallel slots 10 are provided in a lateral wall 8 of the vertical part 4 of the bracket 2 and are connected together by a continuous vertical slot 12.

**[0011]** Said surface is also provided with two slits 14 which define two flexible tabs 16.

**[0012]** The vertical part 4 of the bracket 2 is slidably inserted into a corresponding tubular sleeve 18, the upper end of which is rigid with a pad 20.

**[0013]** One, 22, of the larger lateral surfaces of the sleeve is provided with two ribs 24, which define a longitudinal cavity 26, one end of which is provided with a seat 28.

**[0014]** At the other end of the cavity 26, a substantially square aperture 30 is provided in the sleeve surface.

**[0015]** The invention also comprises a lever-shaped push-element 32 which presents at one end a reduced-thickness step 34 insertable into the seat 28, an intermediate rib 36 which rests on the surface of the cavity 26 to form a fulcrum for the push-element, and at its other end 38 is inclined oppositely to the intermediate rib 36 and bent at 90° into two T-shaped appendices 40.

**[0016]** In particular, the heads 42 and the shank 44 of the appendices 40 are of a size and shape suitable for insertion into two horizontal adjacent slots 10 and into a vertical slot 12, respectively, of the wall 6 of the bracket 2.

**[0017]** To assemble the armrest, the procedure is as follows:

after inserting the reduced-thickness step 34 into the seat 28 and inserting the end 38 into the aperture 30, the push-element 32 is pushed right down so that it rotates on the intermediate appendix 36, and the upper part of the bracket 2 is inserted into the bottom of the sleeve 18.

**[0018]** During this insertion, the shank 44 deflects the two tabs 16 to then engage in the slot 12.

**[0019]** When the push-element is released, the heads 42 of the appendices 40 become inserted into two of the horizontal slots 10, to again prevent axial sliding of the sleeve relative to the bracket (see Figures 3 and 4).

**[0020]** To adjust the height of the pad 20, the push-element 32 has merely to be pressed at its end 38 so as to cause this end 38, by virtue of its material elasticity, to rotate relative to the intermediate appendix 36 on the sleeve lateral surface, such as to disengage the heads 40 from the slots 10 and be able to slide the sleeve relative to the bracket (see Figures 5 and 6).

**[0021]** When the desired adjustment has been achieved, the end 38 of the push-element 32 is released such that the elastic reaction of the previously stressed material causes the heads 40 to again engage in the slots 10.

**[0022]** In the embodiment illustrated in Figures 7 and 8, the edges of the lateral wall 8' facing the wall 8 of the vertical part 4 of the bracket are provided with two seats 46 provided with pegs 48 engaging in holes 50 provided in elastic strips 52 housed in the seats 46.

**[0023]** This embodiment has the advantage of a reduc-

tion in slack when the bracket is inserted into the sleeve.

### Claims

1. An armrest for office chairs, comprising an L-shaped tubular bracket (2) with the horizontal part (6) engageable in the support structure of the seating portion, a tubular sleeve (18) provided upperly with a pad (20), said tubular sleeve being slidable relative to the vertical part (4) of said L-shaped bracket, **characterised in that:**

- a lateral surface (8) of the vertical part (4) of the L-shaped bracket (2) is provided with a plurality of horizontal parallel slots (10) connected together by a vertical slot (12),
- a lateral surface (22) of the tubular sleeve is provided with an aperture (30) able to selectively face said slots (10),

and **characterised by** comprising a lever-type push-element (32) having one end (34) inserted into a seat (28) provided in the outer lateral surface of the sleeve (18), an intermediate transverse rib (36) which rests on the outer surface of the sleeve and forms the fulcrum for the push-element (32), and its other end (38) provided with an appendix (40) inserted into the aperture (30) and engaged, when in the rest configuration, in one of the slots (10) and disengageable therefrom by pressing on said **other** end (38) toward the sleeve. (18)

2. An armrest as claimed in claim 1, **characterised in that** each appendix consists of a T-shaped appendix, the head (42) and shank (44) of which have a size and shape corresponding to that of the slots (10) and of the slot (12), respectively.
3. An armrest as claimed in claim 1, **characterised in that** the edges of that lateral wall (8') facing the wall (8) of the vertical part (4) of the bracket (2) are provided with two seats (46) provided with pegs (48) in holes (50) provided in elastic strips (52) housed in the seats (46).

### Patentansprüche

1. Armlehne für Bürostühle, umfassend eine L-förmige röhrenartige Halterung (2), deren horizontaler Teil (6) in die Trägerstruktur des Sitzabschnitts einrastbar ist, eine röhrenartige Hülse (18), die oben mit einer Stütze (20) versehen ist, wobei die röhrenartige Hülse bezogen auf den vertikalen Teil (4) der L-förmigen Halterung verschiebbar ist, **dadurch gekennzeichnet, dass:**

- eine laterale Oberfläche (8) des vertikalen Teils (4) der L-förmigen Halterung (2) mit einer Vielzahl von horizontalen parallelen Aussparungen (10) versehen ist, die durch eine vertikale Aussparung (12) miteinander verbunden sind,
- eine laterale Oberfläche (22) der röhrenartigen Hülse mit einer Öffnung (30) versehen ist, die dazu in der Lage ist, den Aussparungen (10) selektiv gegenüberzuliegen,

und **gekennzeichnet durch** das Umfassen eines hebelartigen Schiebeelements (32) mit einem Ende (34), das in einen in der äußeren lateralen Oberfläche der Hülse (18) bereitgestellten Sitz (28) eingeführt ist, einer Zwischenquerrippe (36), die auf der äußeren Oberfläche der Hülse aufliegt und den Drehpunkt für das Schiebeelement (32) bildet, und seinem anderen Ende (38), das mit einem Fortsatz (40) versehen ist, der in die Öffnung (30) eingeführt wird und, wenn in der Rastkonfiguration, in eine der Aussparungen (10) eingerastet wird und durch Drücken auf das andere Ende (38) in Richtung der Hülse davon ausrastbar ist. (18)

2. Armlehne nach Anspruch 1, **dadurch gekennzeichnet, dass** jeder Fortsatz aus einem T-förmigen Fortsatz besteht, dessen Kopf (42) und Schaft (44) eine Größe und Form entsprechend denjenigen der Aussparungen (10) bzw. der Aussparung (12) aufweisen.
3. Armlehne nach Anspruch 1, **dadurch gekennzeichnet, dass** die Kanten der lateralen Wand (8'), die der Wand (8) des vertikalen Teils (4) der Halterung (2) zugewandt ist, mit zwei Sitzen (46) versehen sind, die mit Zapfen (48) in Löchern (50) versehen sind, die in elastischen Bändern (52) bereitgestellt sind, die in den Sitzen (46) untergebracht sind.

### Revendications

1. Un accoudoir pour chaise de bureau, comprenant un support tubulaire en forme de L (2) dont la partie horizontale (6) s'engage dans la structure du support de l'assise, un manchon tubulaire (18) pourvu en sa partie supérieure d'un appui (20), ledit manchon tubulaire pouvant coulisser par rapport à la partie verticale (4) dudit support en forme de L, **caractérisé en ce que :**

- la surface latérale (8) de la partie verticale (4) du support en forme de L (2) est pourvue d'une pluralité de fentes horizontales parallèles (10) reliées entre elles par une fente verticale (12),
- la surface latérale (22) du manchon tubulaire est pourvue d'une ouverture (30) pouvant faire face de manière sélective auxdites fentes (10),

et **caractérisé en ce qu'il** comprend un élément poussoir de type levier (32) dont une extrémité (34) est insérée dans un logement (28) situé dans la surface latérale extérieure du manchon (18), une nervure transversale intermédiaire (36) qui repose sur la surface extérieure du manchon et forme le point d'appui de l'élément poussoir (32), et dont l'autre extrémité (38) est pourvue d'un appendice (40) inséré dans l'ouverture (30) et engagé, lorsqu'il est en position de repos, dans l'une des fentes (10), et pouvant être désengagé de ces dernières en appuyant sur ladite autre extrémité (38) en direction du manchon. (18)

2. Un accoudeur selon la revendication 1, **caractérisé en ce que** chaque appendice est un appendice en forme de T, la tête (42) et la tige (44) de ceux-ci ayant une taille et une forme correspondant à celles des fentes (10) et de la fente (12) respectivement.
3. Un accoudeur selon la revendication 1, **caractérisé en ce que** les bords de cette paroi latérale (8') faisant face à la paroi (8) de la partie verticale (4) du support (2) sont pourvus de deux logements (46) dotés de taquets (48) dans des orifices (50) situés dans des bandes élastiques (52) logées dans les logements (46).

30

35

40

45

50

55

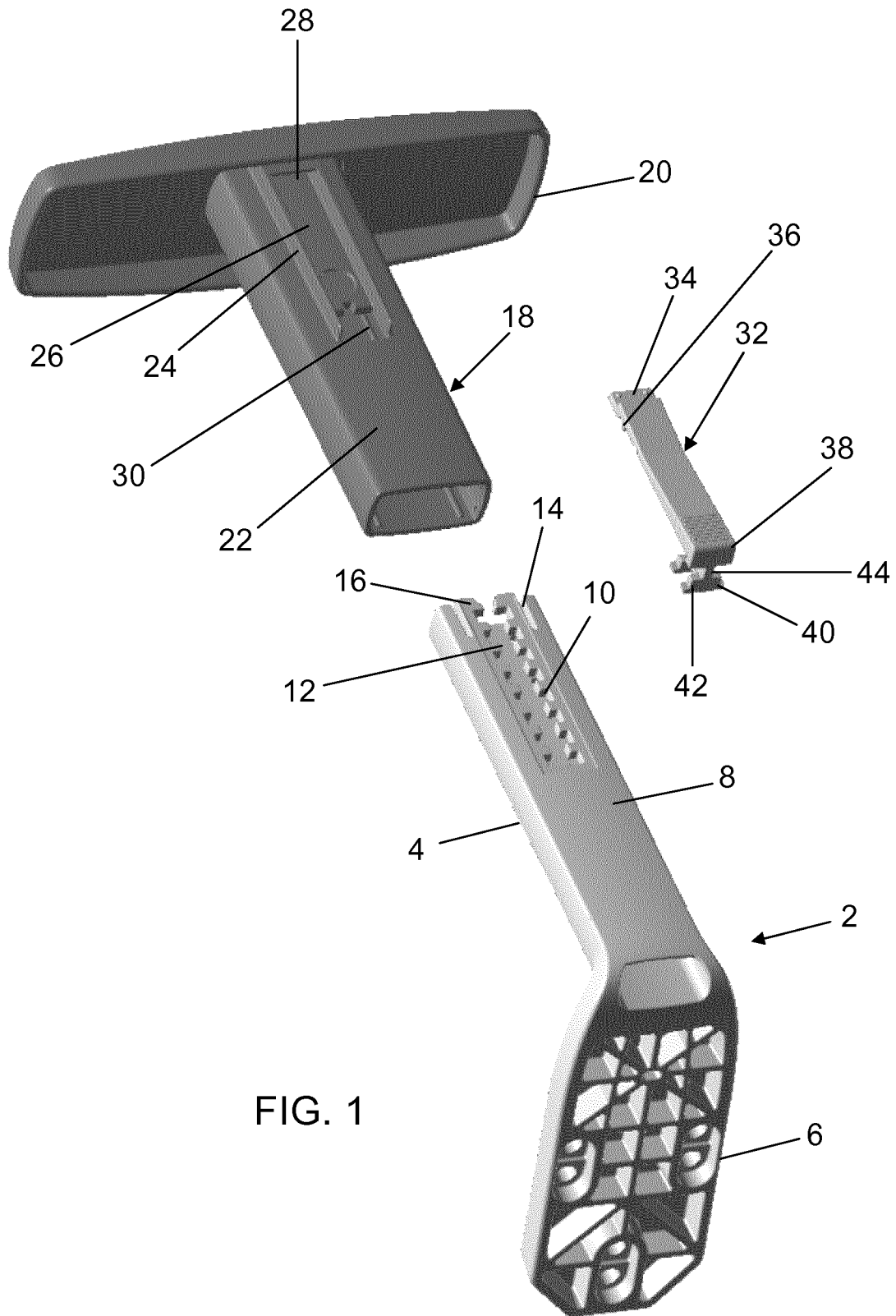
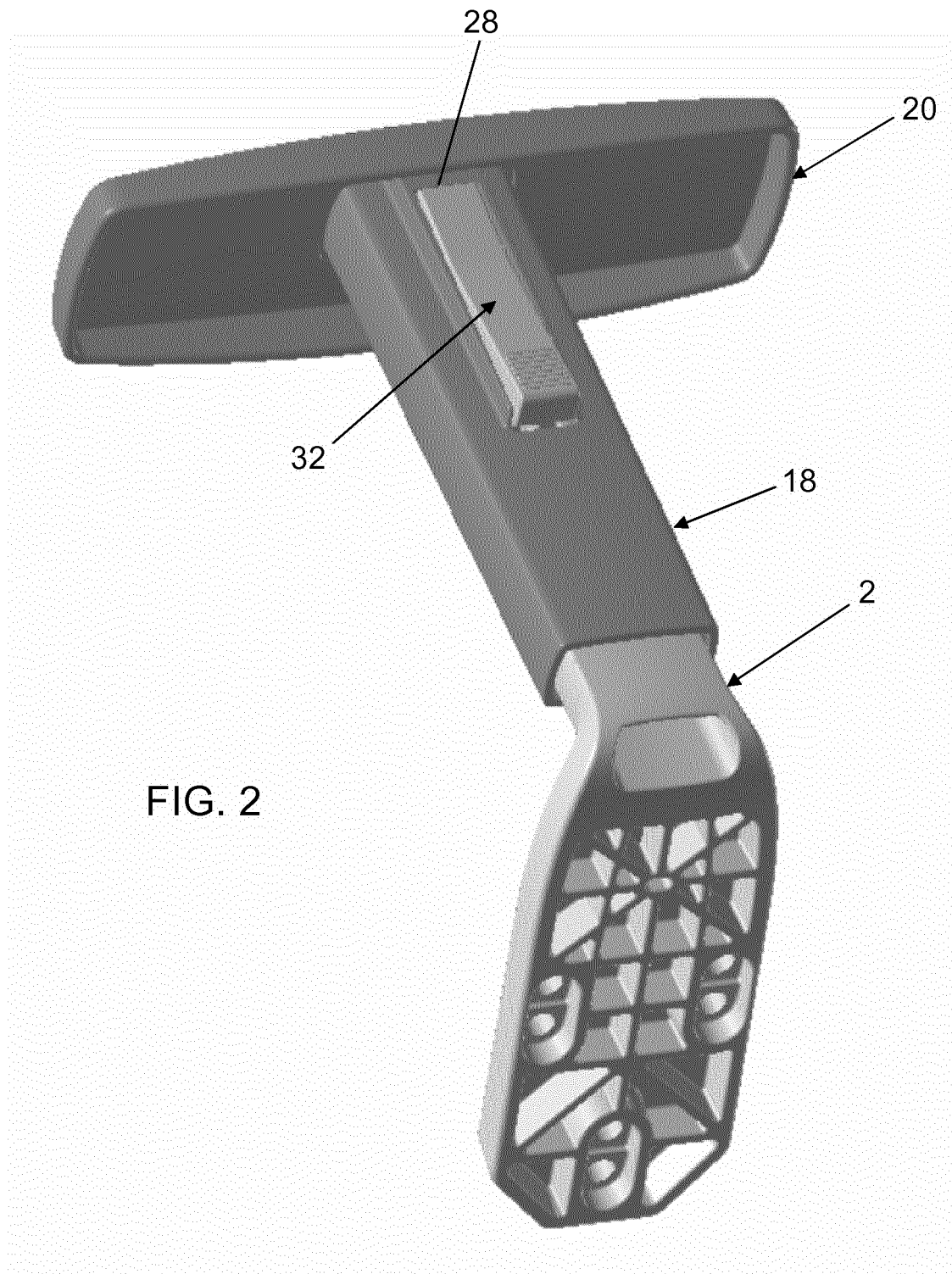
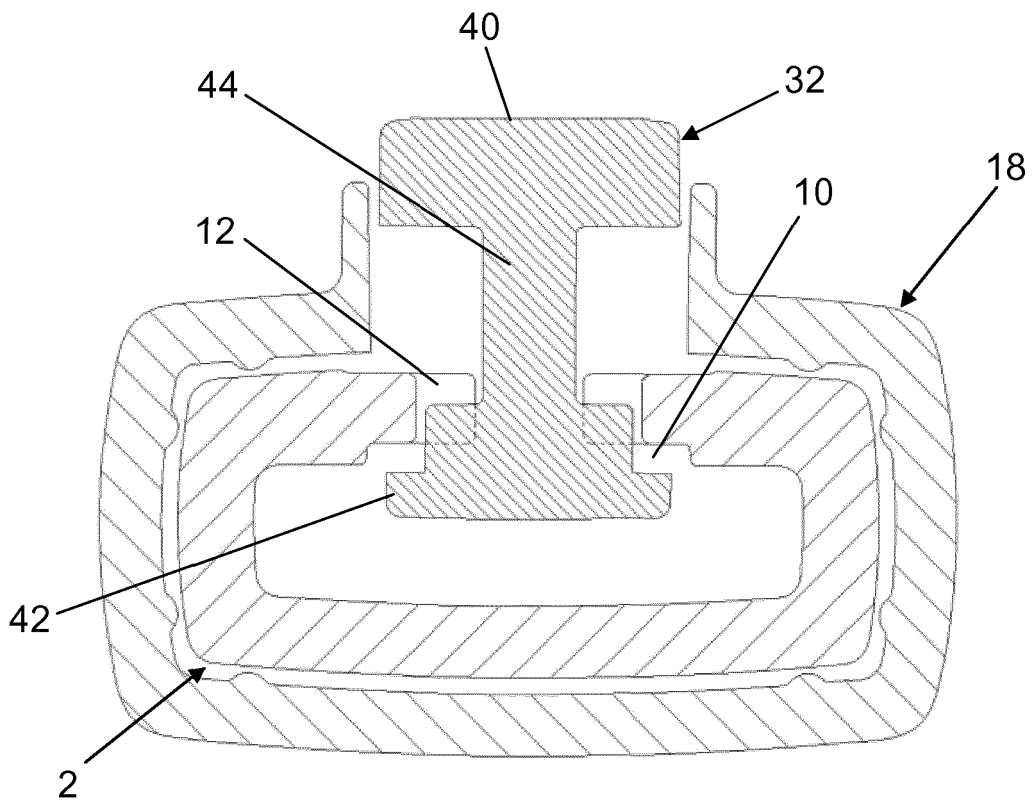
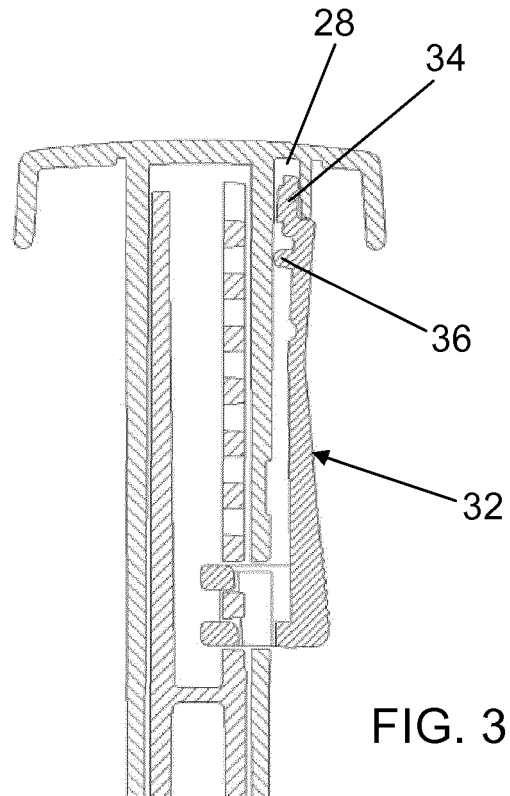

FIG. 1





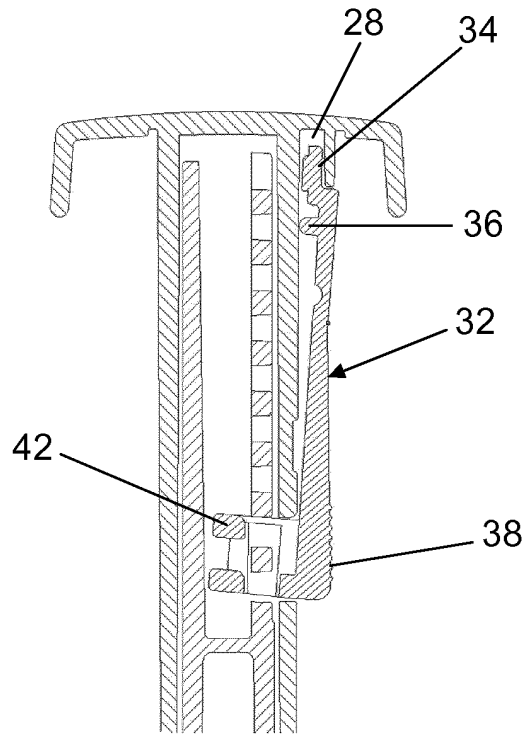

FIG. 5

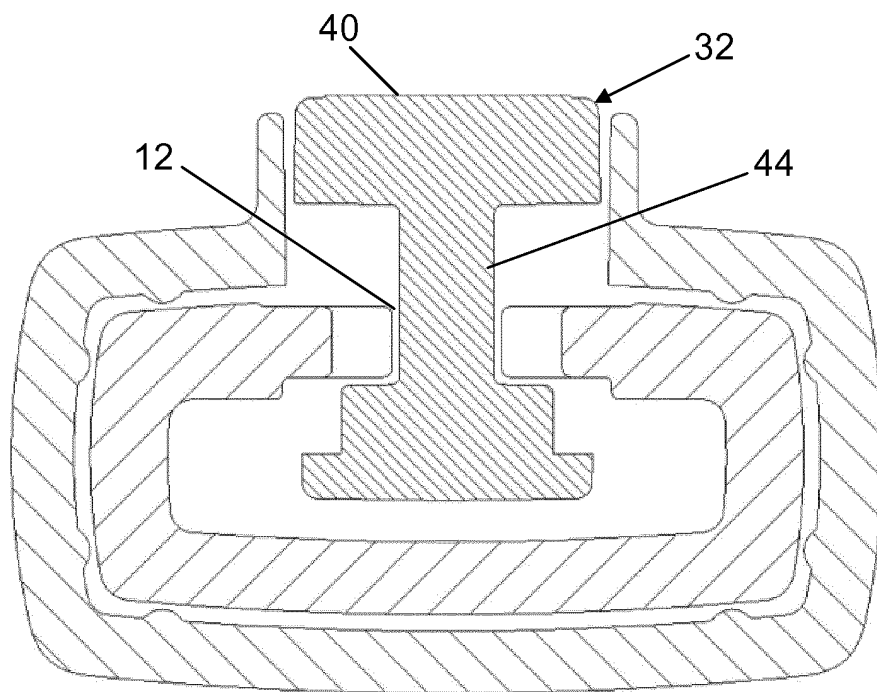
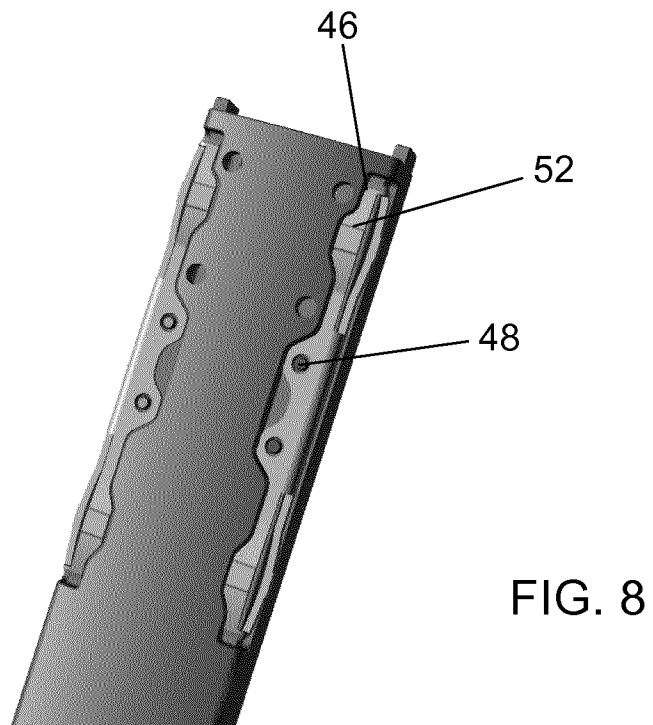
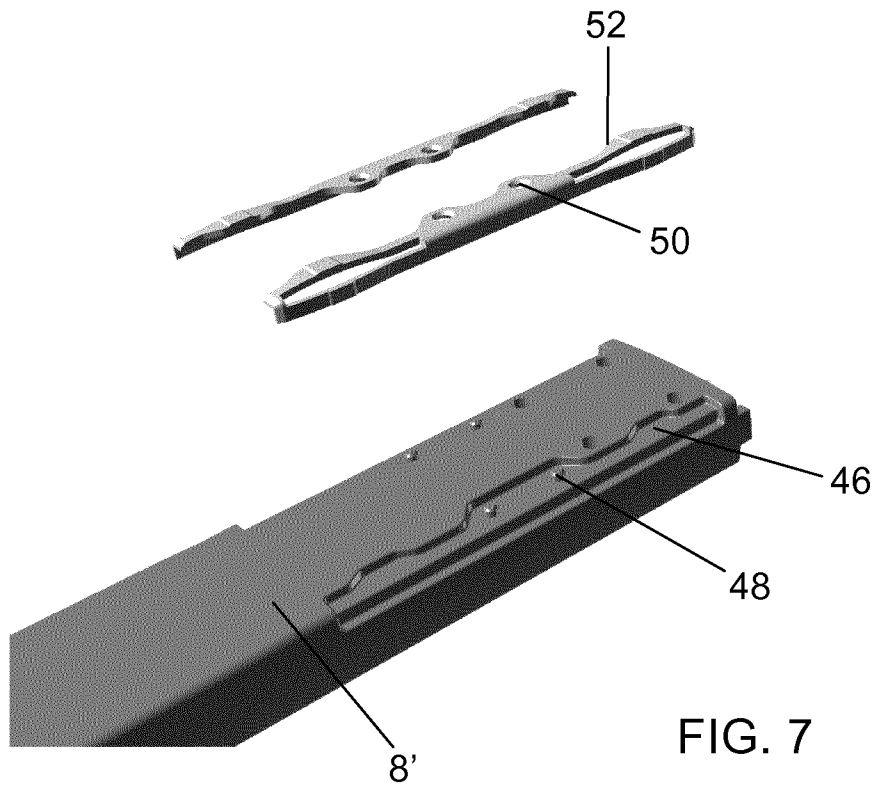

FIG. 6



**REFERENCES CITED IN THE DESCRIPTION**

*This list of references cited by the applicant is for the reader's convenience only. It does not form part of the European patent document. Even though great care has been taken in compiling the references, errors or omissions cannot be excluded and the EPO disclaims all liability in this regard.*

**Patent documents cited in the description**

- CN 2011948441 U [0005]