



(11) **EP 3 091 136 A1**

(12) **EUROPEAN PATENT APPLICATION**

(43) Date of publication:  
**09.11.2016 Bulletin 2016/45**

(51) Int Cl.:  
**E04F 11/18 (2006.01)**

(21) Application number: **16167533.5**

(22) Date of filing: **28.04.2016**

(84) Designated Contracting States:  
**AL AT BE BG CH CY CZ DE DK EE ES FI FR GB GR HR HU IE IS IT LI LT LU LV MC MK MT NL NO PL PT RO RS SE SI SK SM TR**  
Designated Extension States:  
**BA ME**  
Designated Validation States:  
**MA MD**

(72) Inventors:  
• **van Vlastuin, Cornelis**  
**3771 MB Barneveld (NL)**  
• **Cluistra, Dick**  
**3771 MB Barneveld (NL)**

(74) Representative: **V.O.**  
**P.O. Box 87930**  
**Carnegieplein 5**  
**2508 DH Den Haag (NL)**

(30) Priority: **01.05.2015 NL 2014755**

(71) Applicant: **EeVenture B.V.**  
**3771 MB Barneveld (NL)**

(54) **FRAMELESS GLASS BALUSTRADE AND METHOD OF OBTAINING SAME**

(57) The invention is directed at a prefabricated cast concrete floor element (1) in combination with a at least one glass panel (27) forming a balustrade. The glass panel (27) is frameless and positioned with a lower edge directly within a recessed groove (3). The recessed

groove (3) being integrally formed in an upper surface (4) of the concrete floor element (1), and the glass panel (27) is separated from concrete walls of the recessed groove (3) by elastic spacer means (29, 33).

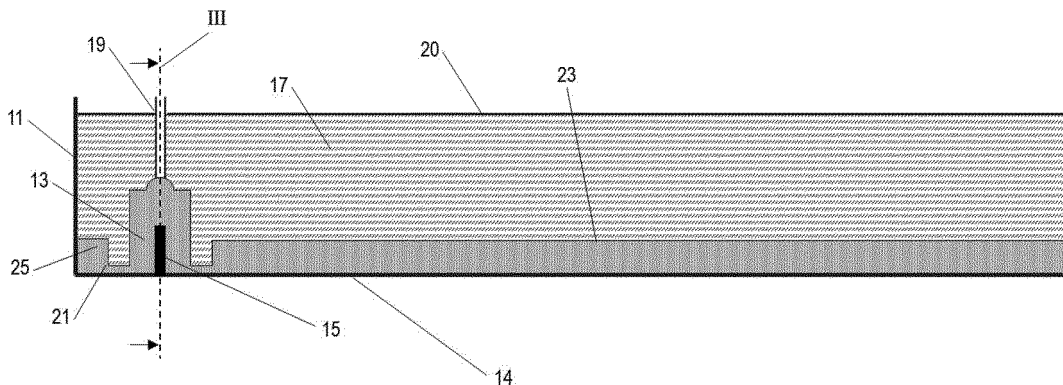

Fig. 2

**EP 3 091 136 A1**

## Description

**[0001]** The invention relates to a frameless glass balustrade in particular in combination with at least one concrete floor element. More in particular the invention relates to a combination of a prefabricated cast concrete floor element and at least one frameless glass panel forming a balustrade. The invention also relates to a method of forming an integral groove in cast concrete floor elements for receiving an edge of a glass panel therein.

**[0002]** A plate shaped balustrade attached to an edge of a floor in a building construction is known from Dutch patent document NL 1035234. This known balustrade uses a mounting profile that has a flange attached to the floor edge, and a U-shaped accommodation space for receiving the plate shaped balustrade element. The balustrade element can be a glass panel, but as shown in this known arrangement it is provided with an upper railing. To obtain full benefit of an unobstructed view through glass panels, such panels are preferably used without frames, which presents a challenge to their mounting especially when structural security is needed, such as with balcony balustrades. Also the use of mounting profiles and railings in the known balustrade may obstruct free view, or may esthetically be objectionable.

**[0003]** Accordingly it is an object of the present invention to propose an improved frameless glass balustrade in combination with a concrete floor element, and method of obtaining same. In a more general sense it is thus an object of the invention to overcome or reduce at least one of the disadvantages of the prior art. It is also an object of the present invention to provide alternative solutions which are less cumbersome in assembly and operation and which moreover can be made relatively inexpensively. Alternatively it is an object of the invention to at least provide a useful alternative.

**[0004]** To this end the invention provides for a frameless glass balustrade and method of obtaining same as defined in one or more of the appended claims.

**[0005]** By positioning the glass panel with a lower edge thereof directly within a recessed groove integrally formed in the concrete floor element, and by separating the glass panel from concrete walls of the recessed groove by elastic spacer means, it has become possible to eliminate all mounting hardware that is usually involved. Furthermore an unobstructed view has been obtained thereby. The elastic spacer means in particular can contain at least one of rubber, sealant and caulking. When in one embodiment the glass panel is separated from a bottom of the recessed groove by at least one preformed rubber element, it becomes very convenient to position the glass panel without any risk of damage.

**[0006]** Also a drain hole can be provided that extends between a bottom of the groove and a lower surface of the floor element opposite the upper surface. This can be particularly advantageous when the prefabricated concrete floor element is installed at a building site, while

the glass panels are to be installed at a later stage. In such a situation any water spillage or rain collecting in the recessed groove can drain off through the drain hole, before it would interfere with the mounting of the glass panel. Notably the structural integrity of sealant or caulking could be seriously compromised, when any water would be present in the groove.

**[0007]** In forming a recessed groove in a cast concrete floor element of various sizes, and with various groove arrangements, it can be advantageous to have core elements with complementary ends that can be coupled with one another to obtain different lengths and arrangements. Further core elements can be provided for forming drain holes, and advantageously these can also be connected with the groove forming core elements.

**[0008]** The invention will further be elucidated by description of some specific embodiments thereof, making reference to the attached drawings. The detailed description provides examples of possible implementations of the invention, but is not to be regarded as describing the only embodiments falling under the scope. The scope of the invention is defined in the claims, and the description is to be regarded as illustrative without being restrictive on the invention. Further advantageous aspects of the invention will become clear from the appended description and in reference to the accompanying drawings, in which:

Figure 1 is a schematic cross-sectional illustration of an exemplary embodiment of a prefabricated concrete floor element;

Figure 2 is a schematic cross-sectional illustrations of an in-mould concrete floor element according to Fig. 1 during the hardening step in the moulding procedure;

Figure 3 is a cross-sectional illustration as indicated at III, in Fig. 2;

Figure 4 depicts a cross-sectional illustration of a finished product, wherein a prefabricated cast concrete floor element is provided with a frameless panel;

Figure 5a-e are perspective views of various embodiments;

Figure 6 shows a top view of an arrangement of core element;

Figure 7 is a cross-section of the core elements as indicated at VII, in Fig. 6;

Figure 8 illustrates a first top view of assembled core elements of Fig. 6 and 7;

Figure 9 illustrates a top view of assembled core elements in an alternative arrangement; and

Figure 10 illustrates a cross-sectional view similar to Figure 3 of an embodiment of assembled core elements and a concrete floor element during the hardening step in the moulding procedure.

**[0009]** Figure 1 schematically depicts a cross-section of an embodiment of the prefabricated concrete floor el-

ement 1. The element 1 is provided with a recessed groove 3 formed in an upper surface 4 of the concrete floor element 1. An elevation 5 along the substantially horizontal upper surface 4 of the floor element 1 surrounds the recessed groove 3 and a drain hole 7 which extends between a bottom of the recessed groove 3 and a lower surface 2 of the floor element opposite to the upper surface 4.

**[0010]** A schematic cross section of an embodiment of the concrete floor element during the moulding thereof can be seen in Fig. 2. In Figure 2 a mould 11 is provided that has an internal size and form substantially corresponding to a size and form of the floor element 1. The mould 11 comprises at least one elongated first core element 13 having a cross-section that substantially corresponds to that of the recessed groove 3. The first core element 13 can be of a relatively inflexible material, but preferably is of a material that has at least some flexible quality. The first core element 13 can be based on polystyrene, polyurethane foam, expanded thermoset polymers, other synthetic foam materials, elastomer, rubber, or like material. The flexible first core element 13 can be bended to allow for a curvature of a recessed groove to be formed thereby. The first core element 13 is shown to be held in position by an upwardly extending protrusion 15 from an internal bottom surface 14 of the mould 11. The mould 11 is shown to contain an appropriate amount of fluid concrete 17 to form the floor element 1. Further, a second core element 19 possesses a substantially cylindrical form, is provided to extend longitudinally upwards from the surface of the first core element 13 to above the upper surface level 20 of the fluid concrete 17. In this embodiment the second core element 19 can be of a plastic such as a polyvinylchloride, polyethylene, polyurethane or a steel, stainless steel, aluminum or other sturdy materials, and can have a tubular form. The mould 11 further comprises a recess 21 parallel to and along the elongated first core element 13 to form the elevation 5 in the concrete floor element 1 and is shaped in negative of an upper surface 4 of the floor element 1. The mould 11 is further provided with negative surface elements 23, 25. The cross-sectional view of Fig. 3 is parallel to the longitudinal direction of the first core elements 13. The first core elements 13 are depicted in Fig. 3 to be held in place by the upwardly extending protrusion 15 which extends over substantially the length of the first core element 13 in the form of a ridge, this protrusion 15 can also be formed by a series of separate upward protrusions either spaced at intervals, which are preferably regular, by which the core element 13 is held in position. The second core element 19 is provided to extend from the surface of the first core element 13 to above the upper surface level 20 of the fluid concrete 17.

**[0011]** Figure 4 shows a cross-section of an embodiment of the present invention. In this embodiment a pre-fabricated cast concrete floor element 1 is provided with a frameless glass panel 27 positioned with a lower edge in the recessed groove 3 formed in the upper surface 4

of the concrete floor element 1. The glass panel 27 is separated from concrete walls of the recessed groove 3 by means of vertical spacers 29. The concrete floor element 1 contains the elevation 5 along its substantially horizontal upper surface 4 to surround the recessed groove 3. The drain hole 7 extends between a bottom of the recessed groove 3 and the lower surface 2 of the floor element 1. The glass panel 27 extends parallel to an adjacent outer edge 31 of the floor element 1, and is further separated from the bottom of the recessed groove 3 by a horizontal spacer 33. Both the vertical spacers 29 and the horizontal spacers 33 represent elastic spacer means. The elastic spacer means 29, 33 contain at least one of rubber, sealant or caulking.

**[0012]** In one embodiment of the present invention the recessed groove 3 of the floor element 1 and the glass panel 27 are linear and extend parallel to the adjacent outer edge 31, as can be seen in Figure 5a.

**[0013]** Alternatively, the recessed groove 3 of the floor element 1 and glass panel 27 are curved in parallel with an adjacent outer edge 31 of the floor element 1 that is also curved, such as illustrated in Figure 5b.

**[0014]** In yet another embodiment illustrated in Figures 5c-d the recessed groove 3 is formed as a combination of a first longitudinal channel 35 extending parallel to an adjacent first outer edge 39 of the floor element 1, and an at least one second longitudinal channel 37 extending parallel to an adjacent second outer edge 41 of the floor element 1, which is substantially perpendicular to the first outer edge 39. It can be understood that triangular shaped concrete floor elements 1 could similarly be fitted as such.

**[0015]** In Figure 5e an embodiment is shown in which the floor element 1 comprises its recessed groove 3 formed as a combination of a first longitudinal channel 35 and two second longitudinal channels 37, wherein the second longitudinal channels 37 each extend perpendicular to the first longitudinal channel 35 in substantially the same direction.

**[0016]** As mentioned above the first core element 13 is designed to be fixable on the internal bottom surface 14 of the mould 11. Each at least one first core element 13 comprises a first longitudinal end 43 and a second 45 longitudinal end, which are formed to be complementary to each other. The first longitudinal end 43 is preferably also complementary to the radial outer surface of the second core element 19. In Figure 6 it is shown that the first core element 13 is extendable with additional first core elements 13 to vary the total length of the core element. A vertical cross-section parallel to the length of the first core element 13 as indicated by VII in Fig. 6 is shown in Fig. 7. In the cross-sectional view of Fig. 7 it can be seen that in this embodiment the second core element 19 between adjacent core elements 13 extends from the internal bottom surface 14 of the mould 11 to at least above the surface level 20 of the fluid concrete 17 in the mould 11. In this embodiment, the first core element 13 is connected to another first core element 13 and the

second core element 19 by the first longitudinal ends 43 as shown in Figure 8.

**[0017]** In yet another embodiment, illustrated in Figure 9, the first core element 13 is connected to another first core element 13 opposite the second core element 19, but at an angle 47. The longitudinal direction of the first core element 13 is substantially perpendicular to the longitudinal direction of the other first core element 13 as is illustrated in Figure 9. The angle 47 between the longitudinal directions of the first core elements 13 subject to requirement can be varied between 0°-180°.

**[0018]** Figure 10 portrays a cross-sectional view parallel to the first elongated core element 13, similar to Figure 3, of yet another embodiment. In the embodiment of Figure 10 adjacent first core elements 13 comprise confronting first longitudinal ends 43, which receive there between the second core element 19, which then extends from the bottom surface 14 of the mould or from the upwardly extending protrusion 15 to at least above the upper surface level 20 of the cast fluid concrete 17. One of the first core element 13 in this embodiment is equipped to also receive the second core element 19 to extend upwardly from an upper surface thereof to at least above the upper surface level 20 of cast fluid concrete 17.

**[0019]** Accordingly there has been disclosed a prefabricated cast concrete floor element 1 in combination with a at least one glass panel 27 forming a balustrade. The glass panel 27 is frameless and positioned with a lower edge directly within a recessed groove 3. The recessed groove 3 being integrally formed in an upper surface 4 of the concrete floor element 1, and the glass panel 27 is separated from concrete walls of the recessed groove 3 by elastic spacer means 29, 33.

**[0020]** It is thus believed that the operation and construction of the present invention will be apparent from the foregoing description and drawings appended thereto. For the purpose of clarity and a concise description features are described herein as part of the same or separate embodiments, however, it will be appreciated that the scope of the invention may include embodiments having combinations of all or some of the features described. It will be clear to the skilled person that the invention is not limited to any embodiment herein described and that modifications are possible which may be considered within the scope of the appended claims. Also kinematic inversions are considered inherently disclosed and can be within the scope of the invention. In the claims, any reference signs shall not be construed as limiting the claim. The terms 'comprising' and 'including' when used in this description or the appended claims should not be construed in an exclusive or exhaustive sense but rather in an inclusive sense. Thus expression as 'including' or 'comprising' as used herein does not exclude the presence of other elements, additional structure or additional acts or steps in addition to those listed. Furthermore, the words 'a' and 'an' shall not be construed as limited to 'only one', but instead are used to mean 'at least one', and do not exclude a plurality. Features that are not spe-

cifically or explicitly described or claimed may additionally be included in the structure of the invention without departing from its scope. Expressions such as: "means for ..." should be read as: "component configured for ..." or "member constructed to ..." and should be construed to include equivalents for the structures disclosed. The use of expressions like: "critical", "preferred", "especially preferred" etc. is not intended to limit the invention. To the extent that structure, material, or acts are considered to be essential they are inexpressively indicated as such. Additions, deletions, and modifications within the purview of the skilled person may generally be made without departing from the scope of the invention, as determined by the claims.

## Claims

1. Combination of a prefabricated cast concrete floor element and at least one frameless glass panel forming a balustrade, wherein the glass panel is positioned with a lower edge thereof directly within a recessed groove that is integrally formed in an upper surface of the concrete floor element, and wherein the glass panel is separated from concrete walls of the recessed groove by elastic spacer means.
2. Combination according to claim 1, wherein the elastic spacer means contains at least one of rubber, sealant and caulking.
3. Combination according to claim 1 or 2, wherein the recessed groove is formed as a linear channel that extends parallel to an adjacent edge of the floor element.
4. Combination according to claim 1, 2 or 3, wherein the recessed groove is formed as a combination of a first longitudinal channel extending parallel to an adjacent first edge of the floor element, and a second longitudinal channel extending parallel to an adjacent second edge of the floor element that is substantially perpendicular to the first edge.
5. Combination according to claim 1 or 2, wherein the floor element is shaped with a curved edge, and wherein the recessed groove is formed as a curved channel to coextends adjacent to the curved edge.
6. Combination according to one of claims 1 to 5, wherein the glass panel is separated from a bottom of the recessed groove by elastic spacer means including at least one pre-formed rubber element.
7. Combination according to claim 6, wherein the at least one pre-formed rubber element is a strip having a width substantially corresponding to a predefined width of the recessed groove.

8. Combination according to one of claims 1 to 7, wherein a drain hole extends between a bottom of the groove and a lower surface of the floor element opposite the upper surface.
9. Method of forming a recessed groove having a pre-defined transverse cross section for receiving an edge of a glass panel therein in a cast concrete floor element, comprising the steps of:
- providing a mould substantially corresponding to a size and form of the floor element;
  - providing at least one elongate core element having a cross section substantially corresponding to the recessed groove;
  - at least temporarily locating and retaining the at least one core element in respect of the mould;
  - pouring an appropriate amount of fluid concrete into the mould;
  - allowing the poured-in amount of concrete to solidify;
  - removing upon solidification the floor element from the mould together with the at least one core element; and
  - removing the at least one core element from the floor element to obtain the groove as a void left by the at least one core element, after being removed from the floor element.
10. Method according to claim 9, wherein the at least one core element has first and second longitudinal ends that are each formed to be complementary to one another.
11. Method according to claim 10, wherein the first longitudinal end has a recess formed therein, and wherein the second longitudinal end has a prong formed thereon, so that the at least one core element can be coupled on each of its opposite longitudinal ends with core elements having at least one of similar first and second longitudinal ends.
12. Method according to one of claims 9 to 11, wherein the at least one core element is positioned and retained by an internal bottom surface of the mould.
13. Method according to claim 12, wherein the internal bottom surface of the mould has an upwardly extending protrusion, and wherein the at least one core element in a lower surface thereof has a cavity adapted to accommodate the protrusion.
14. Method according to claim 13, wherein the upwardly extending protrusion is formed as a ridge, and wherein the cavity in the at least one core element is formed as an elongate slot.
15. Method according to one of claims 9 to 14, wherein
- the internal bottom surface of the mould is shaped in accordance with a negative of an upper surface of the cast concrete floor element.
16. Method according to claim 14, further including the step of placing a further core element on top of the at least one core element, and allowing it to extend upwardly above an upper surface of the poured-in concrete, so that a drain hole is obtained that in the finished floor element extends between a bottom of the groove and a lower surface of the floor element opposite the upper surface.
17. Method of forming a frameless glass balustrade, comprising the steps of:
- providing a floor element obtained by the method of one of claims 9 to 15;
  - placing elastic spacer means on a bottom of the groove formed in the floor element;
  - inserting a pane of glass of a thickness smaller than a width of the groove with a bottom edge into the groove to rest upon the previously placed elastic spacer means;
  - retaining the glass pane by temporary applied auxiliary support means in a substantially upright position with respect to floor panel, and laterally centered with respect to the groove to allow for a gap at both sides of the glass pane;
  - filling the gaps on both sides of the glass pane with a settable sealant or caulking substance;
  - allowing the sealant or caulking substance to set; and
  - releasing the glass pane from being retained by the auxiliary support means.

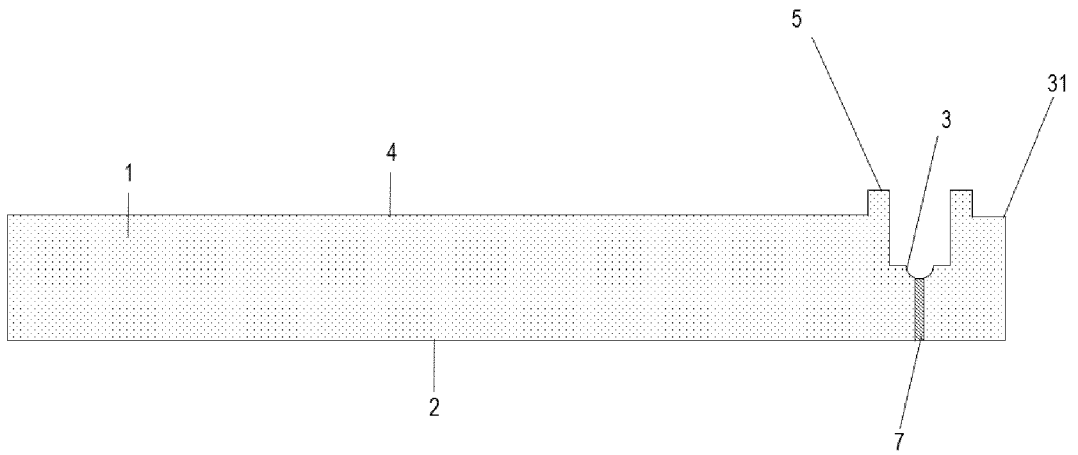

Fig. 1

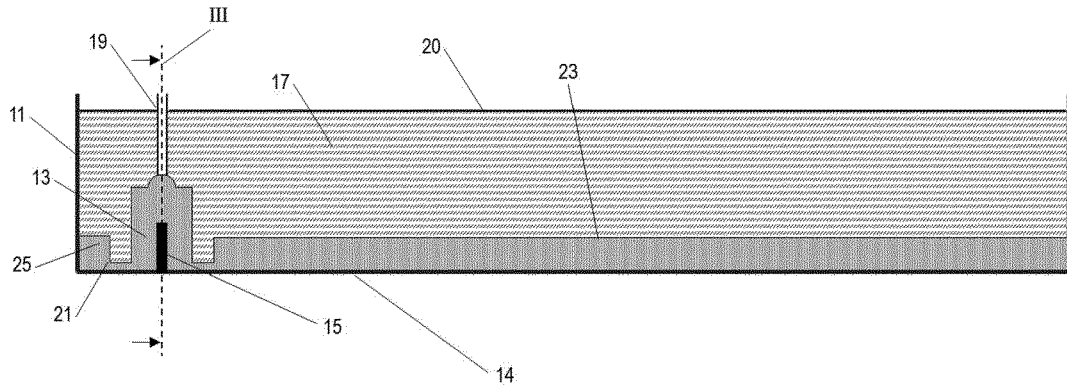

Fig. 2

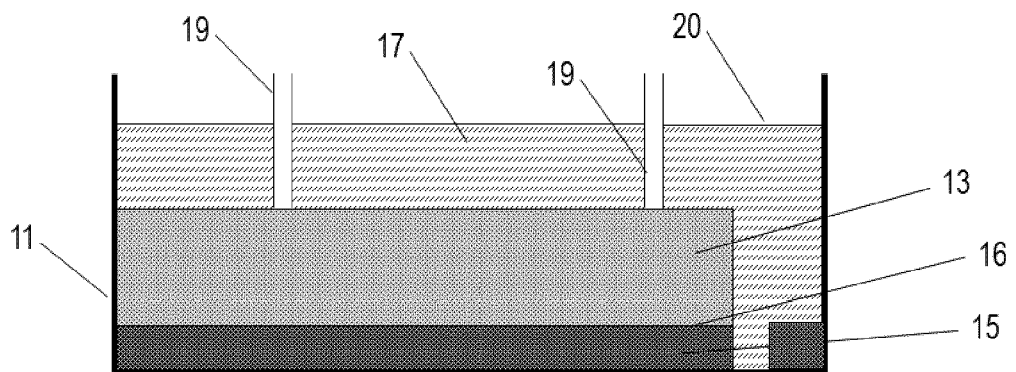

Fig. 3

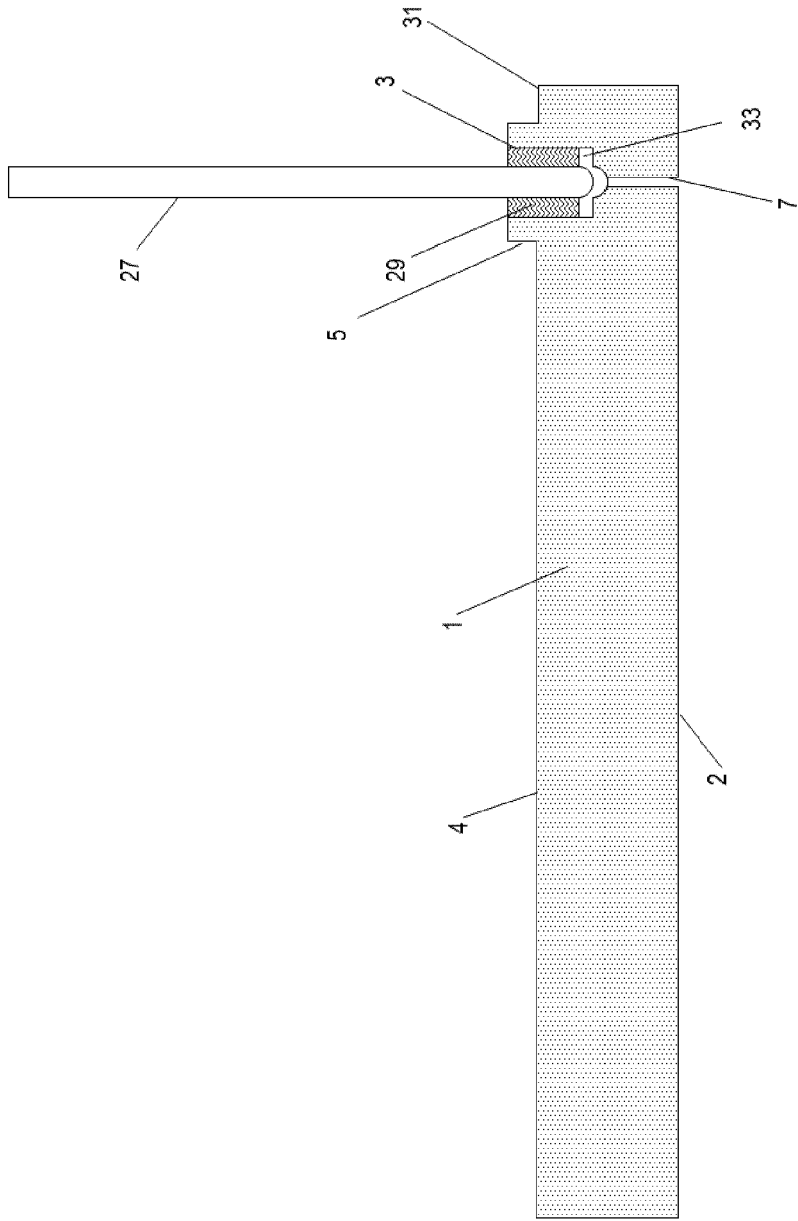

Fig. 4

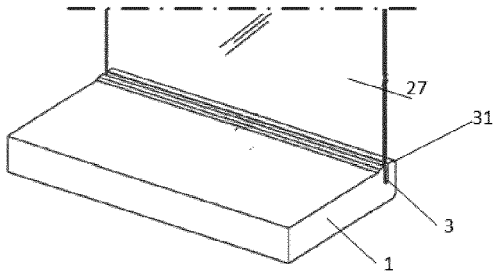

Fig. 5a

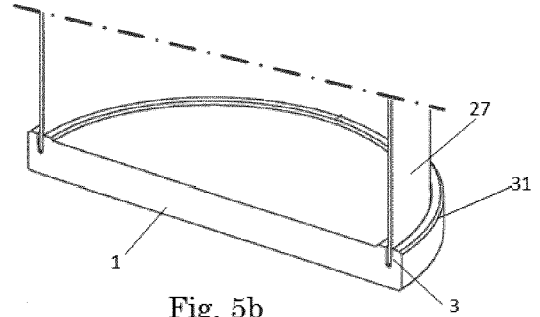

Fig. 5b

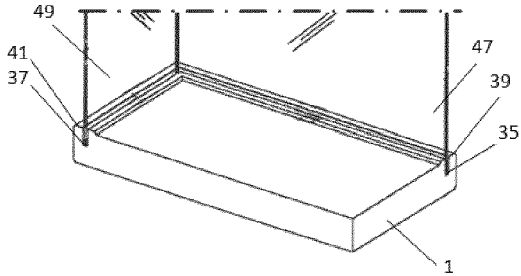

Fig. 5c

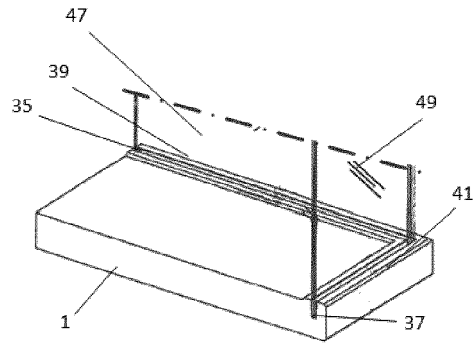

Fig. 5d

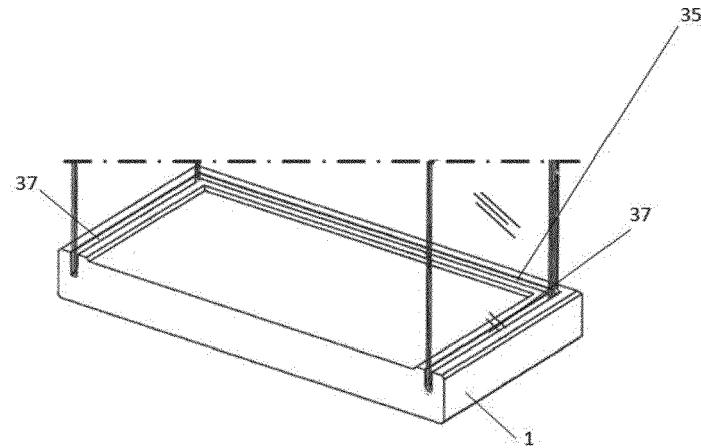

Fig. 5e

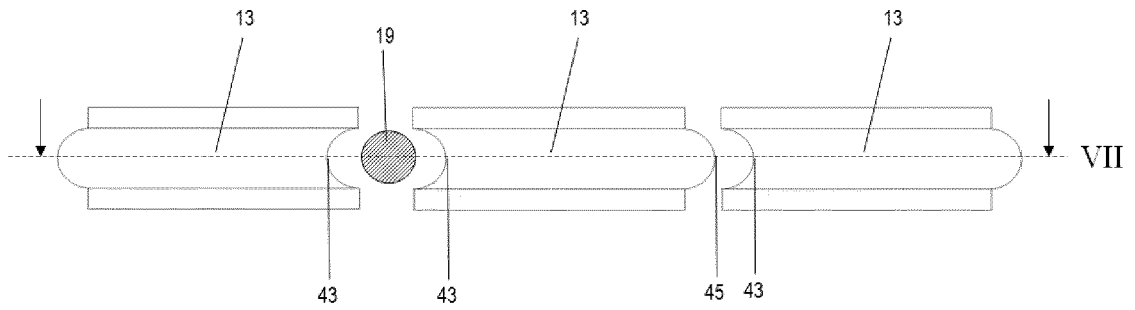

Fig. 6

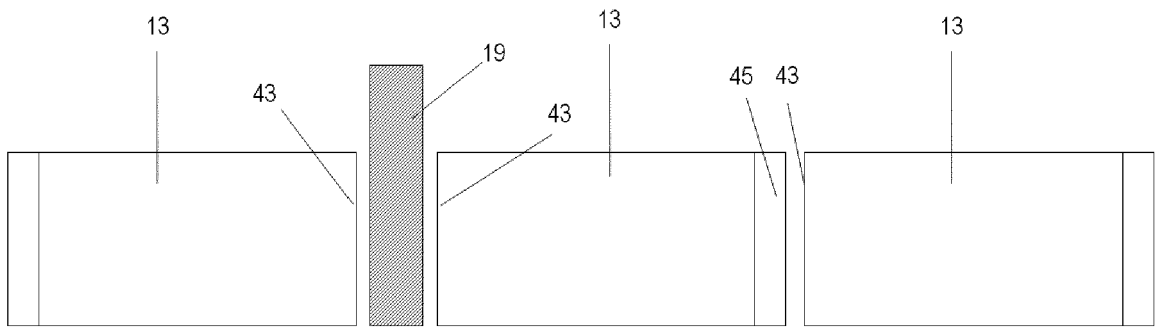

Fig. 7

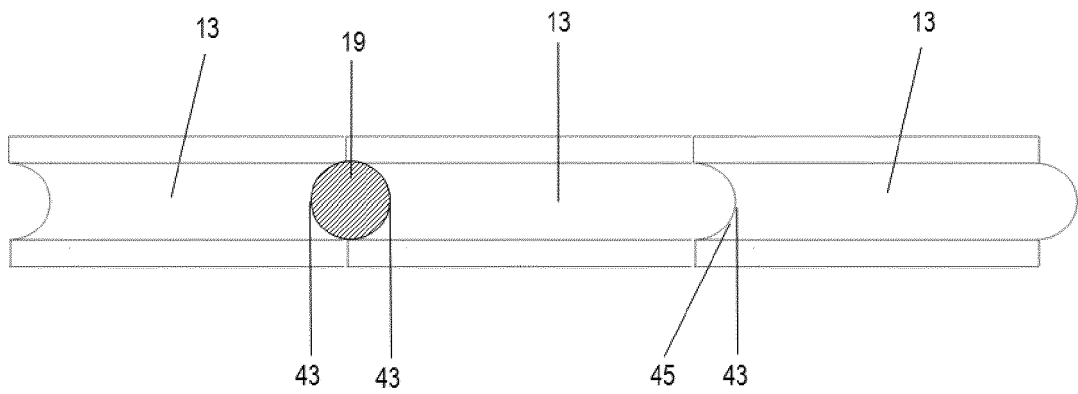

Fig. 8

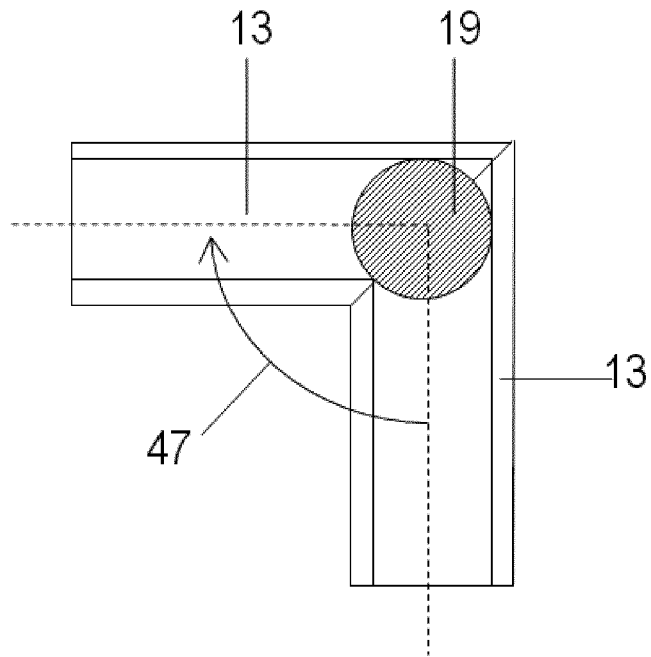

Fig. 9

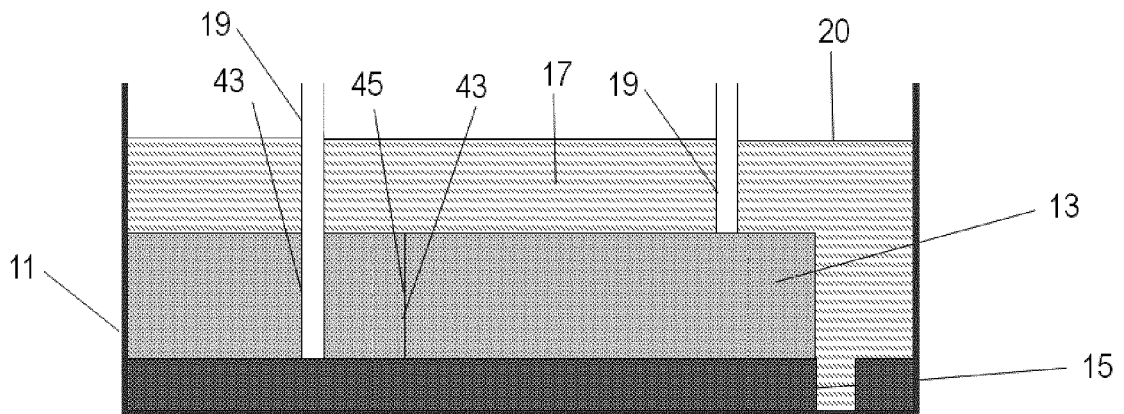

Fig. 10



EUROPEAN SEARCH REPORT

Application Number  
EP 16 16 7533

5

10

15

20

25

30

35

40

45

50

55

DOCUMENTS CONSIDERED TO BE RELEVANT			
Category	Citation of document with indication, where appropriate, of relevant passages	Relevant to claim	CLASSIFICATION OF THE APPLICATION (IPC)
X	GLASMARTE ED - GLASMARTE: "GM Railing flexible, safe, ingeniously simple", GM RAILING, EDITION 2.2,, PAGE(S) 1 - 34  1 January 2009 (2009-01-01), XP002672609, Retrieved from the Internet: URL:http://www.glasstechfacades.co.uk/GM_Railing_GTF.pdf [retrieved on 2012-03-29]	1,3,4,7-9,12,15,17	INV. E04F11/18
Y	* pages 10,14,15 *	2,5,6	
A	* page 1 *	10,11,13,14,16	
Y	----- EP 2 597 221 A1 (FEIGL BERNHARD [AT]) 29 May 2013 (2013-05-29) * figures 2,5 * -----	2,5,6	
			TECHNICAL FIELDS SEARCHED (IPC)
			E04F
The present search report has been drawn up for all claims			
Place of search <b>Munich</b>		Date of completion of the search <b>22 September 2016</b>	Examiner <b>Topcuoglu, Sadik Cem</b>
CATEGORY OF CITED DOCUMENTS X : particularly relevant if taken alone Y : particularly relevant if combined with another document of the same category A : technological background O : non-written disclosure P : intermediate document T : theory or principle underlying the invention E : earlier patent document, but published on, or after the filing date D : document cited in the application L : document cited for other reasons ..... & : member of the same patent family, corresponding document			

EPO FORM 1503 03/02 (P04C01)

**ANNEX TO THE EUROPEAN SEARCH REPORT  
ON EUROPEAN PATENT APPLICATION NO.**

EP 16 16 7533

5 This annex lists the patent family members relating to the patent documents cited in the above-mentioned European search report.  
The members are as contained in the European Patent Office EDP file on  
The European Patent Office is in no way liable for these particulars which are merely given for the purpose of information.

22-09-2016

10  
15  
20  
25  
30  
35  
40  
45  
50  
55

Patent document cited in search report	Publication date	Patent family member(s)	Publication date
EP 2597221	A1	NONE	
-----			

EPO FORM P0459

For more details about this annex : see Official Journal of the European Patent Office, No. 12/82

**REFERENCES CITED IN THE DESCRIPTION**

*This list of references cited by the applicant is for the reader's convenience only. It does not form part of the European patent document. Even though great care has been taken in compiling the references, errors or omissions cannot be excluded and the EPO disclaims all liability in this regard.*

**Patent documents cited in the description**

- NL 1035234 [0002]