



(12) **EUROPEAN PATENT APPLICATION**

(43) Date of publication:  
**23.11.2016 Bulletin 2016/47**

(51) Int Cl.:  
**A61J 13/00** <sup>(2006.01)</sup> **A41C 3/04** <sup>(2006.01)</sup>  
**A61J 15/00** <sup>(2006.01)</sup>

(21) Application number: **15382267.1**

(22) Date of filing: **21.05.2015**

(84) Designated Contracting States:  
**AL AT BE BG CH CY CZ DE DK EE ES FI FR GB GR HR HU IE IS IT LI LT LU LV MC MK MT NL NO PL PT RO RS SE SI SK SM TR**  
 Designated Extension States:  
**BA ME**  
 Designated Validation States:  
**MA**

(72) Inventors:  
 • **Colomé Tresserras, Joaquim**  
**08290 Cerdanyola Del Vallès (ES)**  
 • **Barrón Vayá, Sonia**  
**08290 Cerdanyola Del Vallès (ES)**  
 • **Villegas Alcaide, Minerva**  
**08940 Cornellà De Llobregat (ES)**

(71) Applicant: **Mitelos Bioscience, S.L.**  
**08028 Barcelona (ES)**

(74) Representative: **ZBM Patents - Zea, Barlocchi & Markvardsen**  
**Plaza Catalunya, 1**  
**08002 Barcelona (ES)**

(54) **FLUID DELIVERY NURSING DEVICE AND METHOD FOR SUPPLYING A PRODUCT SIMULTANEOUSLY WITH BREASTFEEDING**

(57) The nursing device (10) comprises at least one nipple shield (100) to be applied at least partially surrounding the mother's nipple, including a main opening (110) through which an infant is allowed to be in direct contact with the mother's breast while breastfeeding; and

first and second holes (120, 130) for adjustably receiving a supply tube (20) therethrough such it can be movably oriented in the main opening (110) so as to supply the product in the vicinity of the mother's nipple.

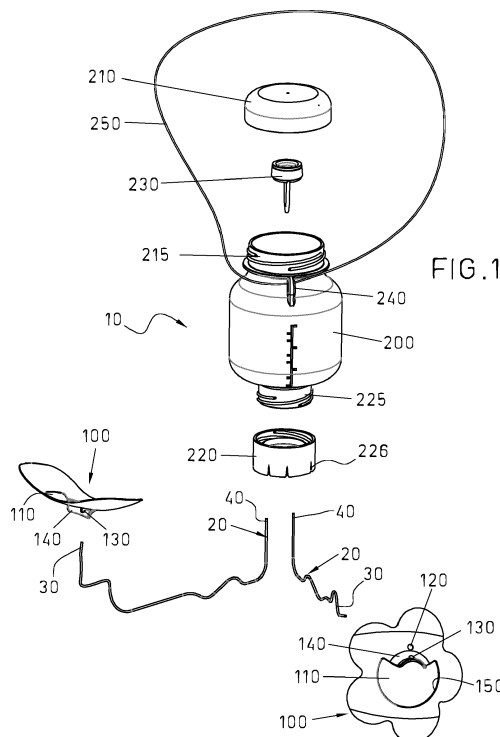

**Description**

## TECHNICAL FIELD

**[0001]** A fluid delivery nursing device for the supply of a product simultaneously with breastfeeding is disclosed herein. A method for supplying a product simultaneously with breastfeeding is also disclosed herein.

## BACKGROUND

**[0002]** Fluid delivery nursing devices are known in the art for supplying extra milk or supplemental products to babies or infants during breastfeeding when mothers supply of milk is low or when the baby is unable to suck enough milk.

**[0003]** Known fluid delivery nursing devices comprise a container, such as a bottle or the like, that can be filled with fresh breast milk, pasteurized milk or any supplemental product. The container has a supply cap that, in use, is connected at a lower portion thereof. A duct support is provided in the supply cap. One or more ducts, such as capillary tubes, are connected through the duct support to the supply cap. The ducts lead to the mother's nipple for delivering the product from the container during breastfeeding. The supply cap of the container is further provided having an air inlet valve element.

**[0004]** For feeding the baby, the parts of the nursing device should be assembled, namely the supply cap, the valve element, the tube or tubes, etc. Specifically, the user must place the valve element to the supply cap and the duct support therein. Then, the user must attach the tube or tube(s) to the mother's skin through the user of adhesive tape. Afterwards, the baby can suckle on the mother's breast while taking the product coming from the container through the tube.

**[0005]** Such prior art devices have been shown to avoid anxiety when breastfeeding problems occur, which often results in mothers rapidly abandoning breastfeeding. It has been also found that babies suckling both from the tube and from the mother's breast milk results in that the mother's milk production is stimulated.

**[0006]** Unfortunately, the nursing devices described above have a number of disadvantages. Using such devices is cumbersome especially taking into account that they are formed of a large number of parts. For example, when different flow rates are required for the supply of the product to the baby, different caps having different valves should be provided. When several tubes are provided, they should be connected one by one to the container supply cap.

**[0007]** The above results in that assembling operations for use and disassembling operations, for example for cleaning tasks, are time consuming. This also results in that the device's manufacture is undesirably complex and costly.

**[0008]** In addition, the container in the prior art nursing devices are not adapted to allow the supplement product

to be prepared therein. For this purpose, different separate containers are usually required. This renders said devices complex and costly.

**[0009]** US5474193 and US4687466 describe devices for providing a supplementary feeding product to infants simultaneously with normal breastfeeding. Such devices include a container for holding the feeding product connected to a flexible tube. One free end of the tube is positioned adjacent a breast nipple such that the feeding product is delivered directly to the infant. The tube is fixed in position only through the use of a piece of medical adhesive tape. This results in that the tube free end can not be properly oriented rendering such devices inefficient.

**[0010]** US6968964 shows a nipple shield for feeding infants including a fluid passageway extending axially and a plurality of discharge openings in the extended end thereof connected through a flexible tube with the interior of the nipple shield. Similarly, US8672877 shows a nursing assembly comprising a nipple shield closed by a nipple having an outlet, including for example a one-way valve, and having fluid dispensing apertures. The nipple shield also includes a fluid source connected to the nipple shield by a tube.

**[0011]** In both cases, the use of closed nipple shield configurations prevents infants from being in direct contact with the mother's breast. In addition, the tubes can not be properly positioned as required since delivery of product is always performed through the fluid dispensing apertures formed in the nipple shield itself.

**[0012]** There is thus still a need for fluid delivery nursing device which are simple in construction and use, and thus cost effective, while allow the product to be properly delivered at a desired position while normal breastfeeding.

## SUMMARY

**[0013]** A fluid delivery nursing device for the supply of a product simultaneously with breastfeeding is described herein. The present nursing device may be used for example for supplementing child feeding, for example for providing nutritional feedings, while breastfeeding.

**[0014]** The present fluid delivery nursing device comprises at least one nipple shield made for example of a suitable flexible material such as silicone or any other suitable, preferably reusable, material. The material nipple shield may be of a transparent or translucent nature, although opaque materials may be also possible.

**[0015]** The nipple shield may have any suitable size and shape. Nipple shield shapes may be for example one selected among rectangular, circular, oval, flower-shaped, in general any shapes with rounded edges, and combinations thereof. Many other examples are of course possible as long as the nipple shield is adapted to be applied on the mother's skin at least partially surrounding the mother's nipple.

**[0016]** The nipple shield in the present fluid delivery

nursing device includes a main opening. The main opening may be formed in a nipple shield central position. Other positions, such as a lateral position, are not ruled out. The nipple shield main opening may be closed, that is the nipple shield may have a closed contour. However,

nipple shield main opening may be also open, that is the nipple shield may have an open contour, that is, the nipple shield may have a substantially U-shaped configuration. **[0017]** The nipple shield main opening is adapted such that an infant is allowed to be in direct contact with the mother's breast while breastfeeding, that is while passing her/his mouth through the nipple shield main opening on the mother's nipple. The fact that the infant is in direct contact with the mother's breast during breastfeeding results in an areola-nipple stimulation that induces the production of breast milk. At the same time this allows baby feeding even in cases where there is difficulty to correctly perform breastfeeding or when the amount of milk sucked by the baby is not enough. As a result, the present device is suitable for infants with weak suction or for those unable to maintain vacuum teaching infants to suck properly.

**[0018]** The nipple shield of the device further includes at least a first hole and at least a second hole. Such holes in the nipple shield are adapted for adjustably receiving a supply tube such as at least one elongated fine soft tubing. Several sets of first holes and second holes may be provided for adjustably receiving corresponding supply tubes at a desired position.

**[0019]** In use, the supply tube is passed through the first and second holes in the nipple shield in a manner that a first end portion of the supply tube can be retained in position and oriented as desired in the main opening so as to supply the product in the vicinity of the mother's nipple. At the same time, the supply tube can be moved, e.g. displaced, relative to the nipple shield for properly positioning the supply tube in the vicinity of the mother's nipple for feeding the infant.

**[0020]** In one example of the present device, the above mentioned first and second holes may be arranged adjacent to each other such that the supply tube is allowed to movably pass therethrough defining a double curved path for the supply of the product in the vicinity of the mother's breast. This is the preferred way to retain the supply tube while, at the same way, having the possibility for a proper orientation for a suitable supply of product while breastfeeding allowing a fast and easy positioning in mother's breast. In this way, the infant or baby may simultaneously suck the nipple and the supplement product from the device. The baby is thus fed conveniently from two sources simultaneously.

**[0021]** The nipple shield may have a projecting portion formed projecting from one inner edge of the main opening, such as outwards to the infant's mouth. This projecting portion of the nipple shield is adapted for properly supporting the first end portion of the supply tube. In one example, the second hole might be formed in said projecting portion of the nipple shield.

**[0022]** The product to be supplied while breastfeeding through the above mentioned supply tube may be contained within a suitable container. The container is a separate element from the nipple shield. The container may be of a flexible nature such that the user may deliver the product contained therein through the supply tube which is connected thereto by squeezing the container. Other different containers may of course be used, such as rigid containers. Although the product inside the container is drawn therefrom by applying suction and/or by squeezing the container, the container itself might be also provided with a plunger for the delivering of the product. Such plunger might be for example a syringe type plunger for properly allowing manual emptying of the container. In some examples, the plunger may be fitted in a loading cap provided in the container which will be described below. However, the plunger may be fitted in other parts of the container.

**[0023]** Flow regulation means may be provided. Such flow regulation means may be adapted for supplying constant flow of product from the container for proper feeding. Said regulation means may be adapted to allow real time adjustment of the output flow rate of product. In some examples, such flow regulation means might be provided in combination with the above mentioned plunger for delivering of the product from the container.

**[0024]** The product to be delivered by the device may be any suitable child supplementing nutritional feeding, antibiotics, analgesics, therapeutic formulations, medications, pharmaceuticals or drugs, breast milk, vitamins, minerals, micronutrients, probiotics, anti-retrovirals, proteins, copper, copper derivatives and combinations thereof.

**[0025]** As stated above, the container includes a loading cap. The loading cap is suitable for closing a loading inlet in the container. A supply cap is also provided for closing a supply outlet in the container. It is envisaged that, in use, the container is positioned such that loading cap, that is, the loading inlet, is in an upper position and the supply cap that is, the supply outlet, is in a lower position.

**[0026]** As stated above, a supply tube is provided. The supply tube may be for example elongated fine soft tubing having a first end portion and a second end portion. The supply tube connects the container with the nipple shield. Specifically, the supply tube is connected to the nipple shield through the first end portion thereof and is in turn connected to the container through the second end portion thereof. It is preferred that the supply tube is fixedly connected to the above mentioned supply cap of the container. In one example, the supply cap of the container may be provided with a number of peripheral slits adapted for inserting, e.g. press fitting, the second end portion of a supply tube such that the product is prevented from flowing inside the supply tube in a desired position such that the second end portion of the supply tube is retained therein. Since the supply cap has the supply tube or tubes fixedly connected thereto, no action is required on the

user's part for assembling the supply tube to the container.

**[0027]** The loading cap of the container may be provided with an air inlet valve adapted to allow air entering the container as the product is being supplied through the supply tube to the infant in the vicinity of the mother's nipple. The container loading inlet is sized for properly loading the product inside the container and even for mixing several products within the container or for suitably mixing powdered milk for breastfeeding. To this effect, the container loading inlet is sized such that a small spoon may be allowed to pass therethrough for preparing the product such as powdered milk or a mixture of products avoiding the use of a separate container for this purpose.

**[0028]** The valve may be provided in the loading cap as mentioned above or in the supply cap or both in the loading cap and the supply cap. A kit of three loading caps each with a supply tube having different diameters to each other may be provided.

**[0029]** The preferred configuration of the present device is with the valve fitted in the loading cap and with the supply cap having the supply tube attached thereto. Therefore, if different flow rates are required, only the supply cap with the supply tubes should be replaced with another supply cap. Also, there are no valves associated with the supply tubes so there is no need to have different valves for different tubes in order to provide different flow rates as in prior art devices.

**[0030]** Due to the reduced number of parts involved, cleaning operations are very simple and fast. After use, the device can be easily and properly cleaned with water.

**[0031]** The loading cap, the supply cap or both may have internal threading for screwing on corresponding external threading of the container. In some cases, however, the loading cap, the supply cap or both may have external threading for screwing on corresponding internal threading of the container. Combined feeding/supply cap and internal/external threading are also envisaged.

**[0032]** The present device is very simple and cost effective while allowing breastfeeding to be improved. The present device has been found to be very efficient in re-lactating mothers, for premature babies, and in general babies with difficulties in normal breastfeeding such as babies with impaired reflexes for sucking and swallowing, leading to feeding difficulties.

**[0033]** The present device may include means for removably attaching the supply tube to the mother's skin. Said supply tube attaching means may comprise, for example, a clamping guide having an adhesive surface to be removably attached to the mother's skin and a supply tube receiving portion for clamping the supply tube therein.

**[0034]** In particular cases where there is no risk for the skin to be irritated by the adhesive, the supply tube attaching means may be for example an adhesive tape such as silicone tape, adhesive hypoallergenic paper tape, or even an adhesive substance applied on the surface of the supply tube.

**[0035]** In other examples, the nipple shield may be adapted to be attached to a nursing bra. Specifically, the nipple shield might be shaped to pass through an opening formed in the nursing bra such that, in use, the nipple shield gets trapped between the nursing bra and the mother's skin. This results in a very efficient positioning of the nipple shield during breastfeeding preventing it from being released.

**[0036]** The above supply tube attaching means together with the first and second holes formed in the nipple shield arranged for allowing the supply tube to movably pass therethrough prevents the tubes from becoming loose avoiding the baby from playing with the tubes during breastfeeding. A proper orientation of the supply tube itself is thus ensured.

**[0037]** With the above described fluid delivery nursing device the supplying of a product simultaneously with breastfeeding can be carried out by performing the following steps.

**[0038]** A container such as for example a 90 - 150 ml bottle is provided within which a product to be supplied has been loaded. The product to be supplied may be prepared previously or it may be prepared inside the container, for example by mixing two or more products or preparing powdered milk. The product to be delivered may be for example milk, antibiotics, analgesics, therapeutic formulations, medications, drugs, vitamins, minerals, micronutrients, probiotics, anti-retrovirals, proteins, and combinations thereof.

**[0039]** The nipple shield is applied to the mother's breast and an end portion of the supply tube that is connected to the container is passed through a first hole and an adjacent second hole in the nipple shield. The supply tube can be displaced through the holes in the nipple shield as desired until the first end portion of the supply tube can be properly oriented. The supply tube is then held in a proper position suitably oriented within the nipple shield main opening. The infant is allowed to put her/his mouth in direct contact with the mother's breast through the nipple shield main opening for breastfeeding while the product inside the container is being delivered through the supply tube.

**[0040]** Additional objects, advantages and features of examples of the present fluid delivery nursing device will become apparent to those skilled in the art upon examination of the description, or may be learned by practice thereof.

#### BRIEF DESCRIPTION OF THE DRAWINGS

**[0041]** Particular examples of the present fluid delivery nursing device will be described in the following by way of non-limiting examples, with reference to the appended drawings, in which:

Figure 1 is a general exploded view of one example of the present fluid delivery nursing device; and

Figures 2 and 3 are perspective views of different examples of nipple shields having a closed main opening;

Figures 4 and 5 are perspective views of different examples of nipple shields having an open main opening; and

Figures 6-8 show examples of nursing bras to which the present the nipple shield of the present fluid delivery nursing device can be applied.

#### DETAILED DESCRIPTION OF EXAMPLES

**[0042]** In the examples shown, the fluid delivery nursing device has been designated as a whole by reference numeral 10. The fluid delivery nursing device 10 is intended for the supply of a product such as milk, antibiotics, analgesics, therapeutic formulations, medications, pharmaceuticals, drugs, vitamins, minerals, micronutrients, probiotics, anti-retrovirals, proteins, copper, copper derivatives and combinations thereof, simultaneously with breastfeeding.

**[0043]** In the example shown in figure 1, the fluid delivery nursing device 10 comprises two nipple shields 100. However, a different number of nipple shields 100 may be employed, such as a single nipple shield 100. The nursing device 10 also includes a container 200 for containing the product, and supply tubes 20 for connecting the container 200 with the nipple shields 100.

**[0044]** The nipple shield 100 in the figures is adapted to be held to the mother's breast by a nursing bra 300. Examples of nursing bras 300 to which the nipple shield 100 may be applied are shown in figures 6-8.

**[0045]** The nipple shields 100 in the example shown are made of a suitable flexible and reusable material such as silicone. As illustrated in figure 1 of the drawings, rectangular and flower-shaped nipple shields 100 are used. However, other suitable shapes may be used such as circular, oval, or any shapes with rounded edges, and combinations thereof.

**[0046]** In general, the shape of the nipple shield 100 is such that it is adapted to be applied on the mother's skin at least partially surrounding the mother's nipple.

**[0047]** As illustrated in the examples of the nipple shields 100 shown in the figures, the nipple shield 100 includes a main opening 110. The nipple shield main opening 110 is adapted such that an infant is allowed to be in direct contact with the mother's breast while breastfeeding. In the figures shown, the nipple shield main opening 110 is formed in a nipple shield central position, however other different positions, such as a lateral, are possible. In the examples shown in figures 1-3, the nipple shield main opening 110 is closed, that is, the nipple shield 100 has a closed contour, while in the examples shown in figures 4-5 the nipple shield main opening 110 is open, that is, the nipple shield 110 has an open contour such that the nipple shield 110 has a substantially U-

shaped configuration.

**[0048]** First and second small holes 120, 130 are formed in the nipple shield 100. The holes 120, 130 in the nipple shield 100 are arranged adjacent to each other for adjustably receiving a first end portion 30 of the supply tube 20. The first end portion 30 of the supply tube 20 is retained in the nipple shield 100 in position at a desired length as the supply tube 20 is allowed to be moved through the holes 120, 130 as required. This allows the first end portion 30 of the supply tube 20 to be properly positioned in the vicinity of the mother's nipple. Since the holes 120, 130 are arranged adjacent to each other, the first end portion 30 of the supply tube 20 passes through them according to a double curved path. Such double curved path can be seen from the supply tube 20 illustrated in right hand side of figure 1.

**[0049]** The baby may thus simultaneously suck the nipple and the supplement product from the container 200, that is, the baby is fed from two sources simultaneously.

**[0050]** As shown in figure 1, the nipple shield 100 has a projecting portion 140. The projecting portion 140 projects outwards from one inner edge 150 of the nipple shield main opening 110 towards the infant's mouth when in use. The projecting portion 140 of the nipple shield 100 has a curved shape for properly supporting the first end portion 30 of the supply tube 20. In the example shown in the figures, the nipple shield second hole 130 is formed in the projecting portion 140. Projection of portion 140 results in that holes 120, 130 are arranged in different planes for defining the above mentioned double curved path.

**[0051]** As to the container 200, in the example shown is a 90 - 150 ml bottle made of a flexible material such that the product contained therein can be delivered through the supply tube 20 that is connected thereto by squeezing the container 200.

**[0052]** The container 200 includes a loading cap 210 for closing a loading inlet 215 of the container 200. For this purpose, the loading inlet 215 of the container 200 has external threading on which internal threading of the loading cap 210 can be screwed on. The loading inlet 215 is sized for properly loading the product into the container 200 enabling a correct preparation and mixture of several products therein such as mixing powdered milk. For example, the loading inlet 215 is sized for allowing a small spoon to pass therethrough avoiding the use of separate containers for preparing the product.

**[0053]** The container 200 also includes a supply cap 220 for closing a supply outlet 225 in the container 200. For this purpose, the supply outlet 225 of the container 200 has external threading on which internal threading of the supply cap 220 can be screwed on.

**[0054]** In other examples of the container 200, the loading inlet 215 and the supply outlet 225 might be provided with internal threading while the loading cap 210 and the supply cap 220 might be provided with external threading. Other combinations such as loading inlet 215 with external threading and supply outlet 225 with internal

threading or vice versa for screwing loading cap 210 and supply cap 220 with corresponding threading are possible.

**[0055]** In use, the container 200 is positioned such that loading cap 210, and thus the loading inlet 215, is in an upper position and the supply cap 220, and thus the supply outlet 225, is in a lower position, as shown in figure 1 of the drawings.

**[0056]** The supply tube 20 is connected to the nipple shield 100 through its first end portion 30 and in turn connected to the supply cap 220 of the container 200 through its second end portion 40. The supply cap 220 is provided with a number of peripheral slits 226 for holding the supply tube 20 through its second end portion 40. This prevents the product from flowing through the tube, for example during manipulation of the device prior to baby feeding when the container has product therein.

**[0057]** An air inlet valve 230 is provided in the loading cap 210 of the container 200. The air inlet valve 230 allows air to enter inside the container 200 when the product contained therein is being supplied through the supply cap 220 and the supply tube 20 to the infant.

**[0058]** With the above described fluid delivery nursing device 10 the supplying of a product simultaneously with breastfeeding can be carried out by performing the following steps.

**[0059]** The nipple shield 100 is applied to the mother's breast. A first end portion 30 of the supply tube 20, whose second end portion 40 is connected to the container supply cap 200, is passed through the first and second holes 120, 130 in the nipple shield 100. The first end portion 30 of the supply tube 20 is left as a free end having a desired length for a proper feeding in the vicinity of the mother's nipple. Once the nipple shield 100 has been applied, the supply tube 20 is moved through the holes 120, 130 in the nipple shield 100 to have the first end portion 30 of the supply tube 20 properly oriented. In this way, the supply tube 20 is held in this proper position suitably oriented within the nipple shield main opening 110. The infant is thus allowed to put her/his mouth in direct contact with the mother's breast through the nipple shield main opening 110 for breastfeeding while the product inside the container 200 is being delivered through the supply tube 20. The container 200 may be hung around the user's neck (not shown) through a suitable means such as for example a cord 250, strip, band or the like as shown in figure 1. The cord, strip, band or the like may be passed through at least one ring 240 formed in the container 200.

**[0060]** Referring to figures 6-8, the nipple shield 100 is sized and shaped to pass through an opening 310 formed in the nursing bra 300 and be positioned therein. As it can be seen in the non-limiting example shown in figure 7, in use, the nipple shield 100 which has been shown in phantom as being hidden by the nursing bra 300, is ready to be positioned onto the mother's skin and pressed thereon by the nursing bra 300. The nipple shield 100 is thus trapped between the nursing bra 300 and the

mother's skin and efficient retained in position during breastfeeding.

**[0061]** Although only a number of particular examples of the present fluid delivery nursing device have been disclosed herein, it will be understood by those skilled in the art that other alternative examples and/or uses and obvious modifications and equivalents thereof are possible. The present disclosure thus covers all possible combinations of the particular examples described. Thus, the scope of the present disclosure should not be limited by particular examples, but should be determined only by a fair reading of the claims that follow. Reference signs related to drawings and placed in parentheses in a claim, are solely for attempting to increase the intelligibility of the claim, and shall not be construed as limiting the scope of the claim.

## Claims

1. A fluid delivery nursing device (10) for the supply of a product simultaneously with breastfeeding, the device (10) comprising at least one nipple shield (100) adapted to be applied at least partially surrounding the mother's nipple, the nipple shield (100) including:
  - a main opening (110) through which an infant is allowed to be in direct contact with the mother's breast while breastfeeding; and
  - at least a first hole (120) and at least a second hole (130) adapted for adjustably receiving a supply tube (20) passing therethrough such that a first end portion (30) of the supply tube (20) can be movably oriented in the main opening (110) so as to supply the product in the vicinity of the mother's nipple.
2. The device (10) according to claim 1, wherein said first and second holes (120, 130) are arranged adjacent to each other such that the supply tube (20) is allowed to movably pass therethrough along a double curved path for the supply of the product in the vicinity of the mother's breast.
3. The device (10) according to claim 1 or 2, wherein the nipple shield (100) has a projecting portion (140) formed projecting from one inner edge (150) of the main opening (110) adapted for supporting said first end portion (30) of the supply tube (20).
4. The device (10) according to claim 3, wherein the second hole (130) is formed in the projecting portion (140).
5. The device (10) according to any of the preceding claims, wherein the nipple shield (100) has the shape of one selected among rectangular, circular, oval, flower-shaped and combinations thereof.

6. The device (10) according to any of the preceding claims, wherein the nipple shield (100) is adapted for being held to a nursing bra (300).
7. The device (10) according to any of the preceding claims, wherein it further includes a container (200) for containing a product, the container (200) comprising a loading cap (210), a supply cap (220) and a supply tube (20), the supply tube (20) having the first end portion (30) connected to the nipple shield (100) and a second end portion (40) connected to the container (200). 5
8. The device (10) according to claim 7, wherein the supply tube (20) is fixedly connected to the supply cap (220) of the container (200). 10
9. The device (10) according to claim 7 or 8, wherein an air inlet valve (230) is provided in the loading cap (210). 15
10. The device (10) according to any of the claims 7 to 9, wherein at least one of the loading cap (210) and the supply cap (220) has internal threading or external threading for screwing on corresponding threading in a loading inlet (215) and a supply outlet (225) of the container (200), respectively. 20
11. The device (10) according to any of the claims 7 to 10, wherein in use the container (200) is positioned such that loading cap (210) is in an upper position and the supply cap is in a lower position. 25
12. The device (10) according to any of the claims 7 to 11, wherein it further includes means for removably attaching the supply tube (20) to the mother's skin. 30
13. The device (10) according to claim 12, wherein the supply tube attaching means comprise at least one selected among silicone tape, adhesive tape, adhesive substance applied on the surface of the supply tube (20), and a clamping guide having an adhesive surface to be removably attached to the mother's skin and a supply tube receiving portion for clamping the supply tube (20) therein. 35
14. The device (10) according to any of the claims 7 to 13, wherein the container (200) includes a plunger for the supply of product to the supply tube (20). 40
15. A method for supplying a product simultaneously with breastfeeding, comprising: 45
- providing a container (200) within which a product to be supplied has been loaded; 50
  - applying a nipple shield (100) to the mother's breast; 55
  - providing a supply tube (20) connected to the container (200);
  - passing an end portion (30) of the supply tube (20) through at least a first hole (120) and an adjacent second hole (130) in the nipple shield (100) such that it is held in position and suitably oriented within the main opening (110) of the nipple shield (100) near the mother's breast; and
  - allowing the infant to put her/his mouth in direct contact with the mother's breast through the main opening (110) of the nipple shield (100) for breastfeeding while the product is allowed to be delivered through the supply tube (20).

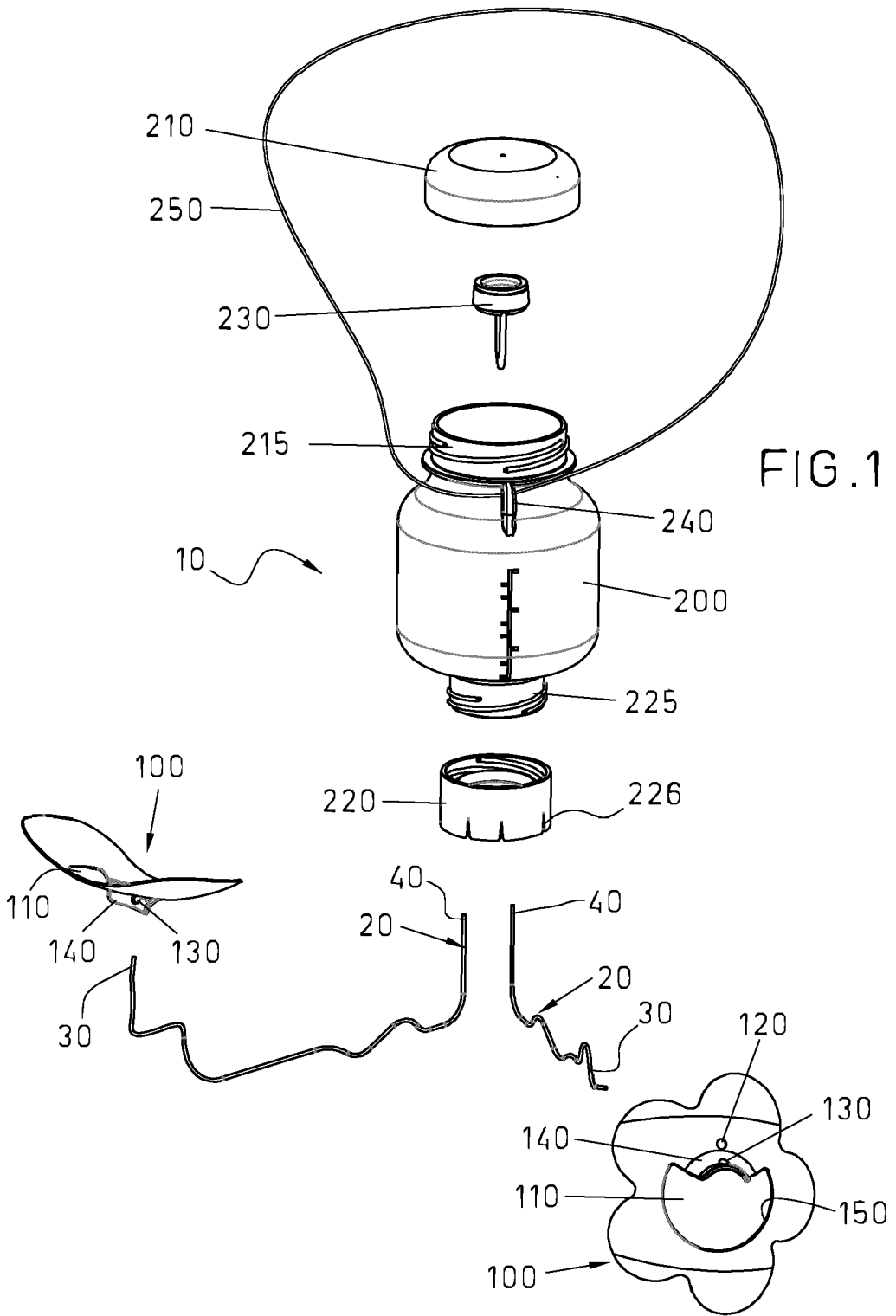

FIG. 2

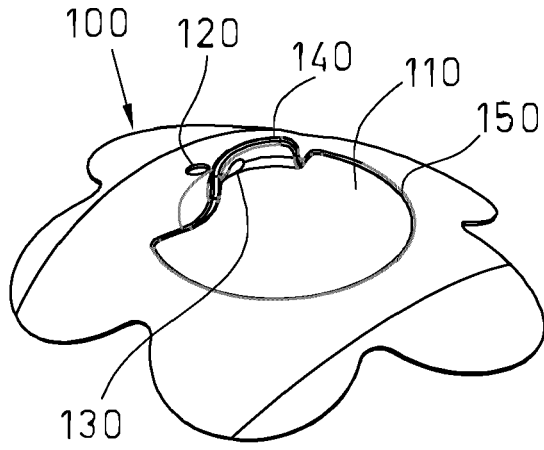

FIG. 3

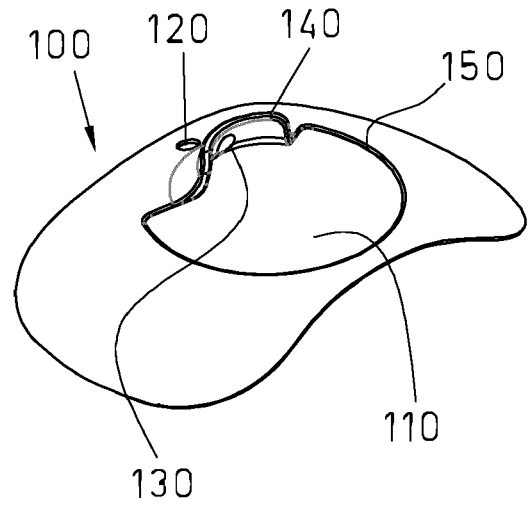

FIG. 4

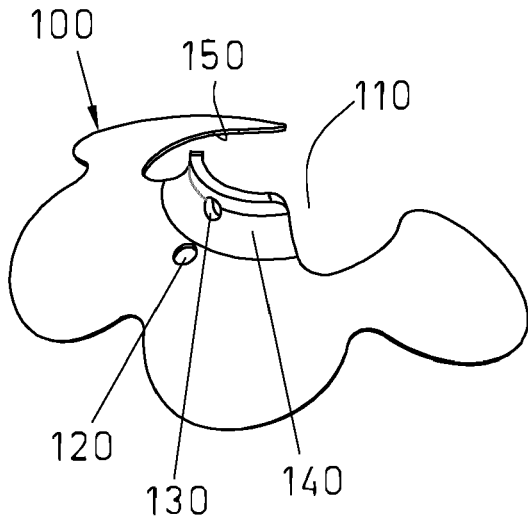

FIG. 5

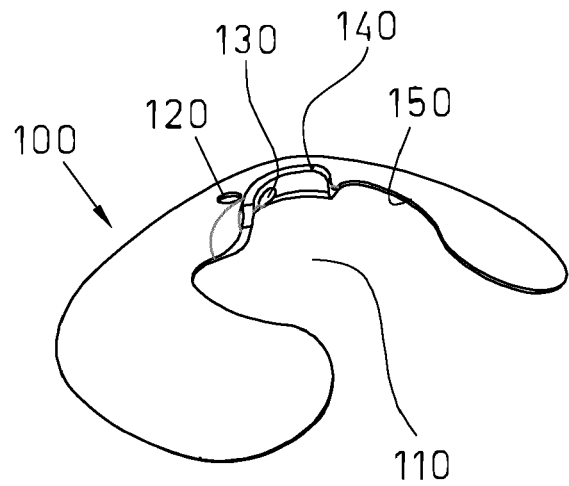

FIG. 6

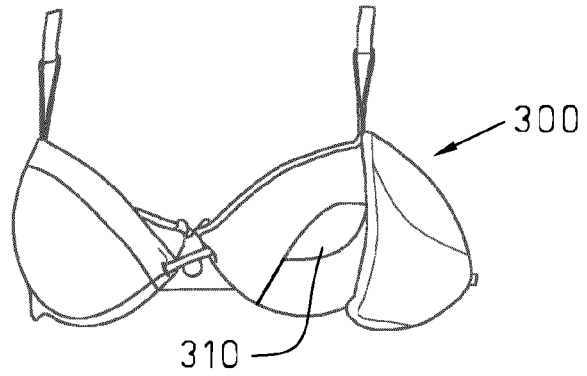

FIG. 7

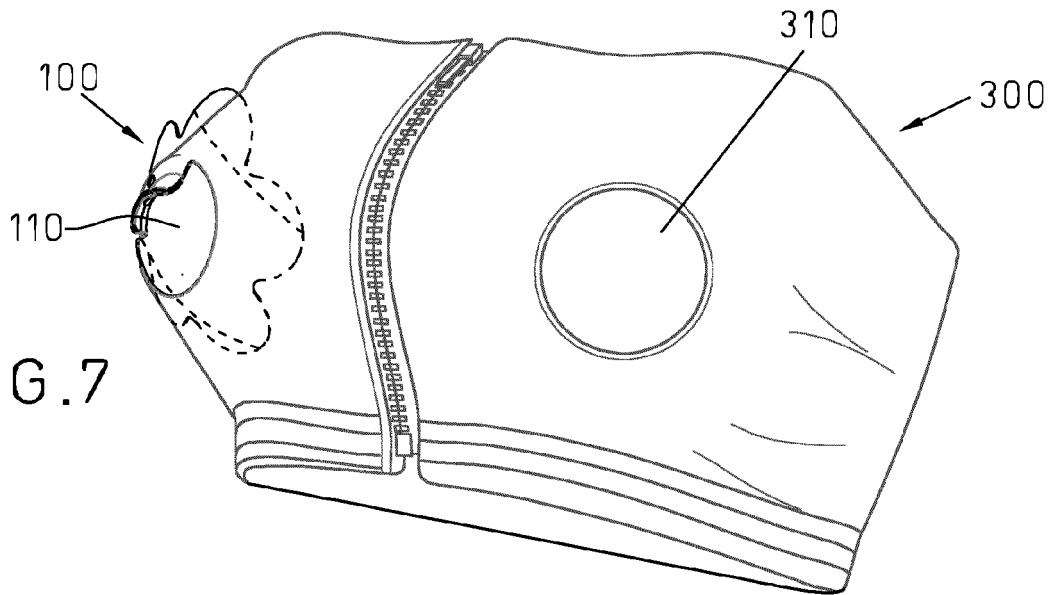
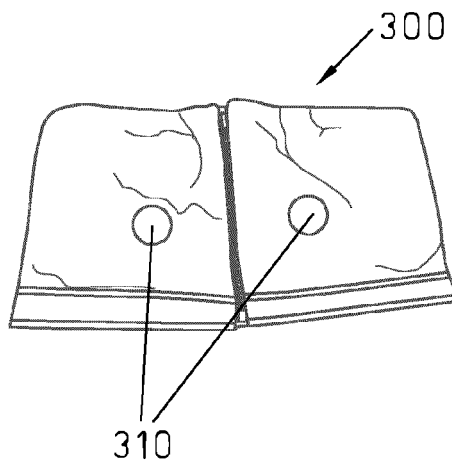

FIG. 8





EUROPEAN SEARCH REPORT

Application Number  
EP 15 38 2267

5

10

15

20

25

30

35

40

45

50

55

DOCUMENTS CONSIDERED TO BE RELEVANT			
Category	Citation of document with indication, where appropriate, of relevant passages	Relevant to claim	CLASSIFICATION OF THE APPLICATION (IPC)
A	KR 2010 0134493 A (LIM GEUN HWI [KR]) 23 December 2010 (2010-12-23) * paragraphs [0005] - [0011]; figures 1-8 *	1,15	INV. A61J13/00 A41C3/04 A61J15/00
A	US 3 757 784 A (AVERY J) 11 September 1973 (1973-09-11) * column 2, lines 14-55; figures 1,4 *	1,15	
A,D	US 4 687 466 A (LARSSON KARL O A H [CH]) 18 August 1987 (1987-08-18) * column 3, line 1 - column 4, line 64; figures 1,2 *	1,15	
A	CN 2 032 883 U (WANG HUANZHANG [CN]) 22 February 1989 (1989-02-22) * figures *	1,15	
A,D	US 5 474 193 A (LARSSON KARL O A H [US] ET AL) 12 December 1995 (1995-12-12) * column 3, line 12 - column 4, line 61; figures 1,3 *	1,15	TECHNICAL FIELDS SEARCHED (IPC) A61J A41C
The present search report has been drawn up for all claims			
Place of search The Hague		Date of completion of the search 17 November 2015	Examiner Petzold, Jan
CATEGORY OF CITED DOCUMENTS X : particularly relevant if taken alone Y : particularly relevant if combined with another document of the same category A : technological background O : non-written disclosure P : intermediate document		T : theory or principle underlying the invention E : earlier patent document, but published on, or after the filing date D : document cited in the application L : document cited for other reasons & : member of the same patent family, corresponding document	

EPO FORM 1503 03/02 (P04C01)

ANNEX TO THE EUROPEAN SEARCH REPORT  
ON EUROPEAN PATENT APPLICATION NO.

EP 15 38 2267

5

This annex lists the patent family members relating to the patent documents cited in the above-mentioned European search report. The members are as contained in the European Patent Office EDP file on The European Patent Office is in no way liable for these particulars which are merely given for the purpose of information.

17-11-2015

10

Patent document cited in search report	Publication date	Patent family member(s)	Publication date
KR 20100134493 A	23-12-2010	NONE	
-----			
US 3757784 A	11-09-1973	NONE	
-----			
US 4687466 A	18-08-1987	AU 6586386 A	11-06-1987
		CA 1267118 A	27-03-1990
		JP S62133961 A	17-06-1987
		US 4687466 A	18-08-1987
-----			
CN 2032883 U	22-02-1989	NONE	
-----			
US 5474193 A	12-12-1995	NONE	
-----			

15

20

25

30

35

40

45

50

55

EPO FORM P0459

For more details about this annex : see Official Journal of the European Patent Office, No. 12/82

**REFERENCES CITED IN THE DESCRIPTION**

*This list of references cited by the applicant is for the reader's convenience only. It does not form part of the European patent document. Even though great care has been taken in compiling the references, errors or omissions cannot be excluded and the EPO disclaims all liability in this regard.*

**Patent documents cited in the description**

- US 5474193 A [0009]
- US 4687466 A [0009]
- US 6968964 B [0010]
- US 8672877 B [0010]