

(19)



(11)

EP 3 107 081 A1

(12)

EUROPEAN PATENT APPLICATION

(43) Date of publication:
21.12.2016 Bulletin 2016/51

(51) Int Cl.:
G09F 1/10 (2006.01) **G09F 15/02 (2006.01)**
G09F 7/18 (2006.01) **G09F 7/04 (2006.01)**
G09F 7/12 (2006.01)

(21) Application number: **16174370.3**

(22) Date of filing: **14.06.2016**

(84) Designated Contracting States:
**AL AT BE BG CH CY CZ DE DK EE ES FI FR GB
 GR HR HU IE IS IT LI LT LU LV MC MK MT NL NO
 PL PT RO RS SE SI SK SM TR**
 Designated Extension States:
BA ME
 Designated Validation States:
MA MD

(72) Inventors:
 • **STOKES, Glyn**
 London, E3 3PB (GB)
 • **PATTISON, Daniel**
 London, E3 3PB (GB)
 • **BARROW, Lascelle**
 London, E3 3PB (GB)

(30) Priority: **16.06.2015 GB 201510475**

(74) Representative: **Hanson, William Bennett**
Bromhead Johnson
Sovereign House
212-224 Shaftesbury Avenue
London WC2H 8HQ (GB)

(71) Applicant: **AUGUSTUS MARTIN LIMITED**
London E3 3PB (GB)

(54) **ADVERTISING DISPLAYS**

(57) A box 2 for use in a display arrangement contains at least one magnet 8 for magnetically attaching an attachment face 4 of the box to a background graphic sheet. At least one display face 6 of the box 2 is provided with a micro suction layer 14 for supporting a graphic element. A display apparatus including the box 2 com-

prises a background substrate, including an adhesive layer or other means for attachment to a metallic back-board, and a micro suction layer on a side opposite the attachment means. The background graphic sheet has a smooth side for attachment to the micro suction layer, and a graphic on an opposite side of the sheet.

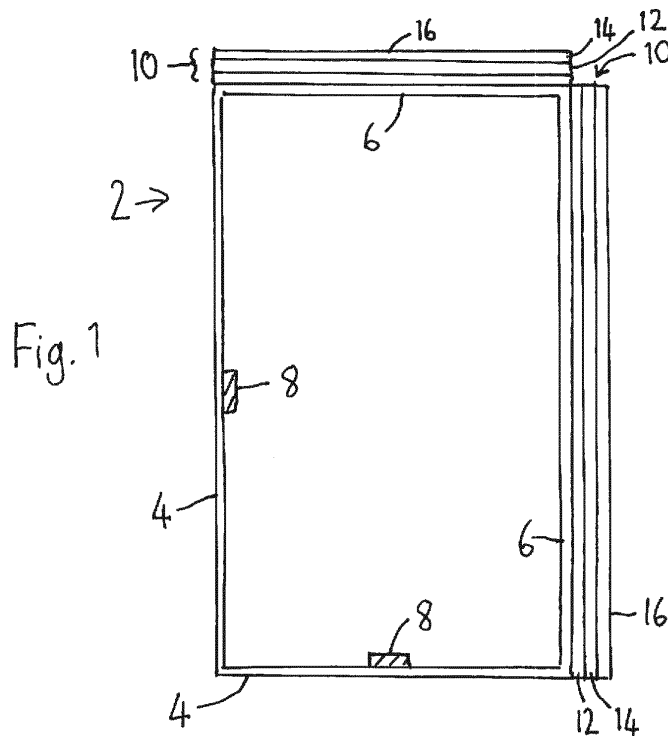

EP 3 107 081 A1

Description

[0001] This invention relates to display apparatus, for example for use in a store.

[0002] WO 2014/045050 describes a display system comprising a display substrate attached to a wall, the substrate including a micro suction layer facing away from the wall. A graphic display sheet is provided on an inner side with a micro vacuum receptor layer, such as a varnish, for enhanced attachment to the micro suction layer. Thus, the graphic display sheet is interchangeable, without replacing the more expensive micro suction material.

[0003] The invention builds on this known system to provide a display apparatus with an innovative, attractive and reconfigurable structure.

[0004] One aspect of the present invention provides a box for use in a display arrangement, containing at least one magnet for magnetically attaching an attachment face of the box to a background graphic sheet, and having at least one display face provided with a micro suction layer for supporting an item.

[0005] A "box" here is a mainly hollow three-dimensional structure, e.g. of paperboard, cardboard or plastics, which may be a six-sided parallelepiped, e.g. a right parallelepiped, or a prism of non-rectangular cross-section.

[0006] The attachment and display faces of the box can face away from each other.

[0007] The box can have a plurality of such display faces, of differing dimensions. If so, the box can also have a plurality of such attachment faces, each attachment face being opposite a respective display face; each attachment face can have a respective magnet. In this way, it is possible to vary the size, shape, and/or distance from the background graphic sheet, of the display face to be used.

[0008] Another aspect of the present invention provides a display apparatus comprising: (i) a background substrate, including an adhesive layer or other means for attachment to a metallic backboard, and a micro suction layer on a side opposite the attachment means; (ii) a background graphic sheet, having a smooth side for attachment to the micro suction layer, and a graphic on an opposite side of the sheet; (iii) at least one box, as defined above.

[0009] The apparatus can include at least one display item, which can be in the form of a sheet bearing an image on one side, the other side comprising a smooth flat surface for attachment to the micro suction layer of the display face of the box. If the image is designed as a sub-image co-ordinated with a background image of the background graphic sheet, a striking three-dimensional effect can be achieved. The item can have an area larger than the display face of the box.

[0010] The apparatus can include a plurality of such boxes, and if so, each can support a different item. In the case of image-bearing sheets, all facing in the same di-

rection, these can overlap, e.g. if the effective depths of the respective boxes are different.

[0011] The invention will now be described in more detail, by way of example only, with reference to the attached drawings, in which:

Figure 1 is a schematic sectional view of a box according to an embodiment of the invention;

Figure 2 is a schematic sectional view of a backboard arrangement;

Figure 3 shows two boxes according to Figure 1 supported on a backboard arrangement of the type shown in Figure 2; and

Figure 4 shows the arrangement of Figure 3, with image-bearing sheets supported on the respective boxes.

[0012] Figure 1 shows a cuboidal cardboard box 2, having opposite faces of three different sizes. In this example, the ratios of the lengths of the different edges are approximately 1:3:6 (the smallest edge going into the paper in Figure 1), but any suitable combination is possible.

[0013] Each pair of opposed sides of the box comprises a magnetic side 4 and a micro suction side 6. Each magnetic side 4 is provided with a neodymium permanent magnet 8 bonded centrally to the inside of the box. Each micro suction side 6 has an external micro suction material 10 including an adhesive layer 12 adhering the material to the box, and a micro suction layer 14. The polymeric micro suction layer 14, including microscopic voids or apertures, is protected by a polyethylene release paper 16. The magnets 8 and micro suction strips 10 can be applied to opposite sides of a blank which is then folded to form the box 2.

[0014] Figure 2 shows the elements for assembly into a backboard, namely a ferromagnetic, e.g. steel plate 18, a display substrate 20 for attachment to the plate, and a background graphic sheet 22 for removable attachment to the display substrate.

[0015] The display substrate 20 comprises a base layer 24, such as a sheet of paper, card or plastics. A rear side of the base layer 24 bears a layer 26 of permanent, semi-permanent or removable adhesive. The adhesive layer 26 is protected by a release paper 30 which is removed before applying the substrate 20 to the plate 18.

[0016] The opposite, i.e. front, side, of the base layer 24 carries a micro suction coating 32. This polymeric layer, including microscopic voids or apertures, is protected by a polyethylene release paper 34.

[0017] The background graphic sheet 22 comprises a base material 36 of widely available paper, card or printable synthetic material. A rear side of the base material is formed at least partially with a smooth surface to provide a micro vacuum receptor 38. For example, the micro vacuum receptor can be high gloss, silicone free, poly-

ester-based varnish that can be tinted or clear and can be applied in a pattern or as a flood coating.

[0018] A background image or indicia, for example an advertising slogan, 40 is printed on a visible side of the base material 36.

[0019] The thicknesses of the layers are exaggerated in Figures 1 and 2 and are depicted as the same, whereas in reality some of the thicknesses differ by orders of magnitude.

[0020] The display substrate 20 is fixed to the metallic plate 18 and the release paper 28 is removed. The background graphic sheet 22 is then applied to the display substrate 20 and held in place by the vacuum force of the micro suction layer 26.

[0021] Figure 3 shows the assembled backboard with two of the boxes 2 of Figure 1 arranged thereon. One magnetic side 4 of each box is attached to the graphic sheet 22 by the magnetic attraction of the respective magnet 8 to the plate 18. By selecting the magnetic side 4 of the box 2 to be attached, it is possible to vary the distance by which the box projects from the backboard, or to select the size and shape of the micro suction side 6 of the box facing outwardly.

[0022] Figure 4 shows an assembled display in which graphic elements 42 have been applied to the respective boxes 2. These elements are flexible or rigid sheets having a construction similar to the background sheet 22, i. e. a base material with a micro vacuum receptor on a rear side, and an image printed on a front side. The elements 42 have been die cut into the shape of the images. They are combined with the backboard to create a striking advertising display giving an impression of depth. The graphic elements 42 can be made larger than the micro suction sides 6 of the boxes 2, to extend beyond these sides and obscure the boxes. When the boxes 2 project by different distances from the backboard, there can be an overlap between the graphic elements 42. Also, the graphic elements 42 can also extend beyond the edges of the background graphic sheet 22.

[0023] If two or more of the boxes 2 are attached to the backboard in the same orientation, a single graphic element can be attached, spanning the boxes.

[0024] The boxes 2 can alternatively be used as platforms for supporting small objects being displayed.

Claims

1. A box (2) for use in a display arrangement, containing at least one magnet (8) for magnetically attaching an attachment face (4) of the box to a background graphic sheet (22), and having at least one display face (6) provided with a micro suction layer (14) for supporting an item.
2. A box (2) according to claim 1, in the form of a right parallelepiped.

3. A box (2) according to claim 1 or 2, wherein the attachment (4) and display (6) faces of the box face away from each other.
4. A box (2) according to any preceding claim, having a plurality of such display faces (6), of differing dimensions.
5. A box (2) according to claim 4, having a plurality of such attachment faces (4), each attachment face being opposite a respective display face (6).
6. A box (2) according to claim 5, wherein each attachment face (4) has a respective magnet (8).
7. A display apparatus comprising: (i) a background substrate (20), including an adhesive layer (26) or other means for attachment to a metallic backboard (18), and a micro suction layer (32) on a side opposite the attachment means (26); (ii) a background graphic sheet (22), having a smooth side for attachment to the micro suction layer (32), and a graphic (40) on an opposite side of the sheet; (iii) at least one box (2) according to any preceding claim.
8. A display apparatus according to claim 7, including at least one display item (42), in the form of a sheet bearing indicia on one side, an opposed side of the item comprising a smooth flat surface for attachment to the micro suction layer (14) of the display face (6) of the box (2).
9. A display apparatus according to claim 8, wherein the item (42) has an area larger than the display face (6) of the box (2).
10. A display apparatus according to claim 7, 8 or 9, including a plurality of such boxes (2).
11. A display apparatus according to claim 10, when dependant on claim 8 or 9, wherein each of the boxes (2) is arranged to support a respective item (42), and the items overlap each other.

45

50

55

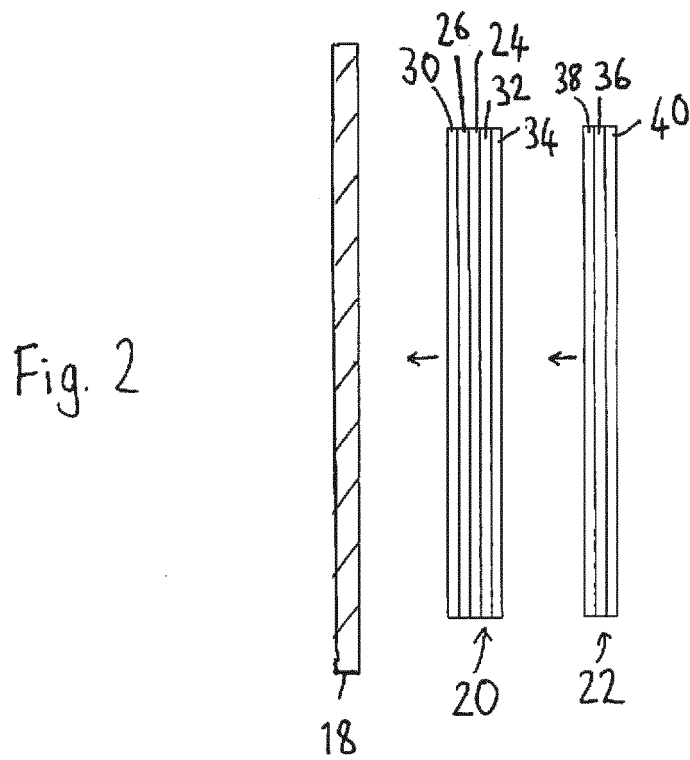
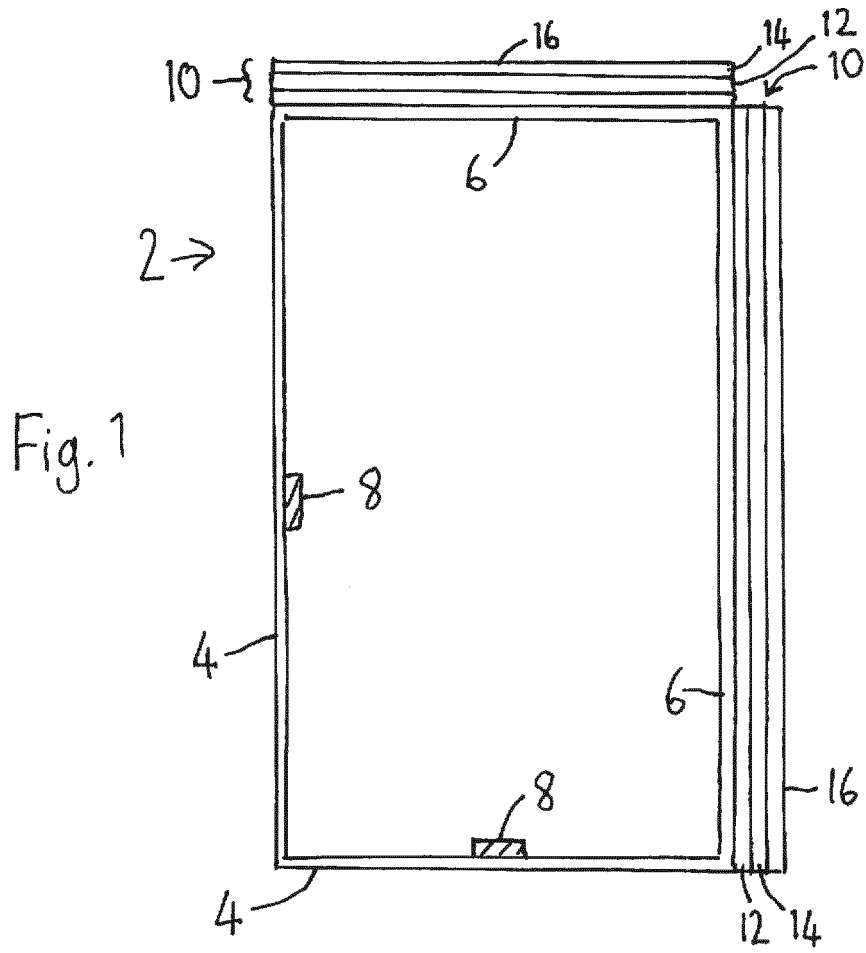

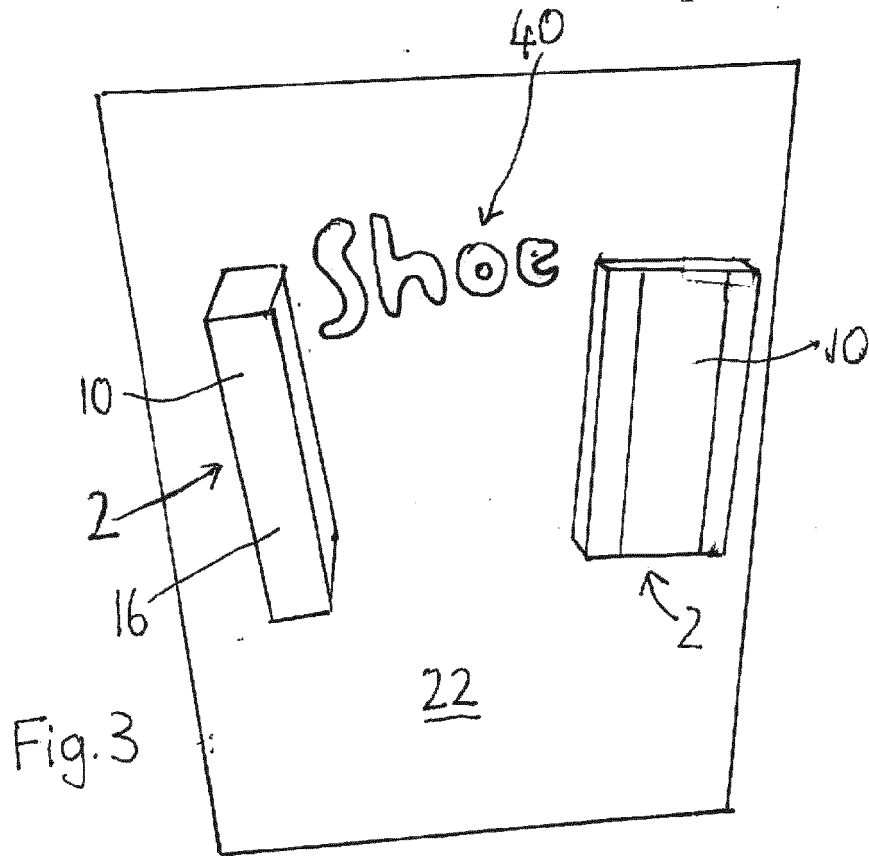



EUROPEAN SEARCH REPORT

Application Number
EP 16 17 4370

5

10

15

20

25

30

35

40

45

50

55

DOCUMENTS CONSIDERED TO BE RELEVANT			
Category	Citation of document with indication, where appropriate, of relevant passages	Relevant to claim	CLASSIFICATION OF THE APPLICATION (IPC)
Y	US 2005/035837 A1 (YAMAZAKI NOBUYUKI [JP] ET AL) 17 February 2005 (2005-02-17)	1-9	INV. G09F1/10 G09F15/02 G09F7/18 G09F7/04 G09F7/12
A	* paragraphs [0022], [0023], [0025], [0030] * * figures 2a-4b *	10,11	
Y	----- JP 2008 114008 A (KUWAHATA KATSUHIKO) 22 May 2008 (2008-05-22)	1-9	
A	* abstract * * figures *	10,11	
A,D	----- WO 2014/045050 A1 (AUGUSTUS MARTIN LTD [GB]) 27 March 2014 (2014-03-27) * paragraphs [0011], [0013], [0014], [0015], [0016] * * figure 1 *	1-11	TECHNICAL FIELDS SEARCHED (IPC) G09F
A	----- JP 2006 292158 A (KUWAHATA YUKIKO) 26 October 2006 (2006-10-26) * abstract * * figures *	1-11	

The present search report has been drawn up for all claims			
Place of search The Hague		Date of completion of the search 8 November 2016	Examiner Lechanteux, Alice
CATEGORY OF CITED DOCUMENTS X : particularly relevant if taken alone Y : particularly relevant if combined with another document of the same category A : technological background O : non-written disclosure P : intermediate document		T : theory or principle underlying the invention E : earlier patent document, but published on, or after the filing date D : document cited in the application L : document cited for other reasons & : member of the same patent family, corresponding document	

EPO FORM 1503 03/02 (P04C01)

**ANNEX TO THE EUROPEAN SEARCH REPORT
ON EUROPEAN PATENT APPLICATION NO.**

EP 16 17 4370

5

This annex lists the patent family members relating to the patent documents cited in the above-mentioned European search report. The members are as contained in the European Patent Office EDP file on
The European Patent Office is in no way liable for these particulars which are merely given for the purpose of information.

08-11-2016

10

Patent document cited in search report	Publication date	Patent family member(s)	Publication date
US 2005035837 A1	17-02-2005	NONE	

JP 2008114008 A	22-05-2008	NONE	

WO 2014045050 A1	27-03-2014	EP 2898499 A1	29-07-2015
		US 2015248853 A1	03-09-2015
		WO 2014045050 A1	27-03-2014

JP 2006292158 A	26-10-2006	NONE	

15

20

25

30

35

40

45

50

55

EPO FORM P0459

For more details about this annex : see Official Journal of the European Patent Office, No. 12/82

REFERENCES CITED IN THE DESCRIPTION

This list of references cited by the applicant is for the reader's convenience only. It does not form part of the European patent document. Even though great care has been taken in compiling the references, errors or omissions cannot be excluded and the EPO disclaims all liability in this regard.

Patent documents cited in the description

- WO 2014045050 A [0002]