



(12) **EUROPEAN PATENT APPLICATION**

(43) Date of publication:
28.12.2016 Bulletin 2016/52

(51) Int Cl.:
B05B 1/16 (2006.01) **B05B 1/18 (2006.01)**
B05B 7/04 (2006.01)

(21) Application number: **16001374.4**

(22) Date of filing: **20.06.2016**

(84) Designated Contracting States:
AL AT BE BG CH CY CZ DE DK EE ES FI FR GB GR HR HU IE IS IT LI LT LU LV MC MK MT NL NO PL PT RO RS SE SI SK SM TR
 Designated Extension States:
BA ME
 Designated Validation States:
MA MD

(72) Inventors:
 • **Chen, Donghai**
361000 Fujian (CN)
 • **Chen, Wenxing**
361000 Fujian (CN)
 • **Liu, Xiaojia**
361000 Fujian (CN)

(30) Priority: **18.06.2015 CN 201510340491**

(74) Representative: **Verscht, Thomas Kurt Albert**
Josephsburgstrasse 88 A
81673 München (DE)

(71) Applicant: **Xiamen Solex High-tech Industries Co., Ltd.**
Fujian 361000 (CN)

(54) **DOUBLE-FUNCTIONAL BUTTON SWITCH SHOWER HEAD**

(57) The present invention is provided with a double-functional button switch shower head, which comprises a fixing portion, a button and a retractable slide shaft driving mechanism. The fixing portion is disposed with an inlet waterway and two diversion waterways, two diversion waterways are respectively disposed with an water diversion hole, two water diversion holes can be connected to the inlet waterway. The button is movably connected to the fixing portion. The retractable slide shaft driving mechanism is assembled in the fixing portion with a slide shaft slidably connected to the fixing portion, the

button is connected to the retractable slide shaft driving mechanism in transmission way to drive the slide shaft to slide; two water diversion holes are arranged in a line along the sliding direction of the slide shaft; the slide shaft is disposed with a switch sealing element, the slide shaft slides to control the switch sealing element to close one of the two water diversion holes alternatively to achieve switch. The present invention has advantages: the structure is compact, the switch mechanism needs small space, the shower head is small in size.

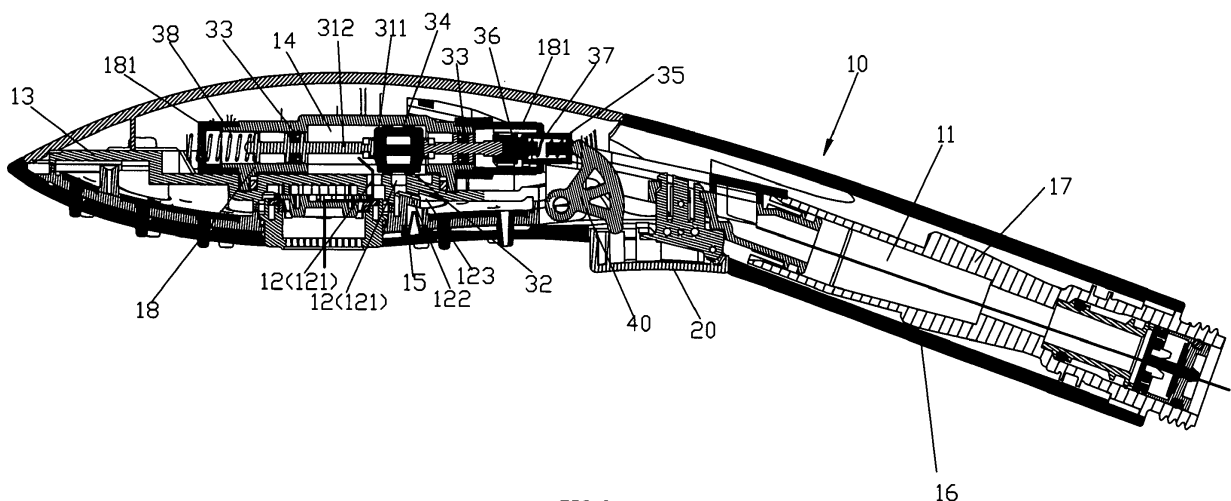

FIG. 3

Description

Field of the invention

[0001] The present invention relates to a double-functional button switch shower head.

Background of the invention

[0002] Existing double-functional button switch shower head is disclosed in the Chinese patent database in May 18th, 2011 with announcement number 201831744U with application title a handle outlet device. The handle outlet device comprises a housing and a water supply pipe assembled in the housing. The water supply pipe comprises a water diversion valve seat with a water diversion chamber; a water diversion valve spool can be pushed to move between two outlets of the water diversion chamber to respectively form a first outlet function and a second outlet function; the button component is used for user to press, the rotating position element is linked to push the water diversion valve to slide upwardly to realize the second outlet function, the rotating position element can be locked to the ratchet block at the bottom end of the water diversion chamber after pushed, the user doesn't need to keep pressing to keep the second outlet function; the elastic component is used to push the water diversion valve spool down elastically to provide a rotating force to the rotating position element and an axial force to escape from the ratchet block when being pushed again. This existing technology has disadvantages, two outlets are arranged vertically that it needs large space for the switch mechanism, which makes the outlet device with large size.

Summary of the invention

[0003] The present invention is provided with a double-functional button switch shower head, which overcomes the disadvantages of the existing technology.

[0004] The technical proposal of the present invention is that: Double-functional button switch shower head, comprising:

a fixing portion (10) and an inlet waterway (11) and two diversion waterways (12), two diversion waterways (12) are respectively disposed with a water diversion hole (121), two water diversion holes (121) are available to connect to the inlet waterway (11); a button (20) movably connected to the fixing portion (10);

a retractable slide shaft driving mechanism (30) assembled to the fixing portion (10), the retractable slide shaft driving mechanism (30) is slidably connected to a slide shaft (31) of the fixing portion (10), the button (20) is connected to the retractable slide shaft driving mechanism (30) in transmission way to drive the slide shaft (31) to slide;

wherein two water diversion holes (121) are parallel arranged in a line with space along the sliding direction of the slide shaft (31); the slide shaft (31) is disposed with a switch sealing element (32), the slide shaft (31) slides to control the switch sealing element (32) to close one of the two water diversion holes (121) alternatively to realize switch.

[0005] In another preferred embodiment, the fixing portion (10) comprises a head portion and a handle portion fastened together, the button (20) is movably disposed to the handle portion or the connecting of the handle portion and the head portion.

[0006] In another preferred embodiment, the fixing portion (10) is disposed with a cover plate component (13), the sliding direction of the slide shaft (31) is parallel to the cover plate component (13).

[0007] In another preferred embodiment, a pendulum shaft (40) is further provided, the pendulum shaft (40) is connected to the fixing portion (10) in swag way, the button (20) is connected to the fixing portion (10) in sliding way, the button (20) slides to drive the pendulum shaft (40) to swag, the pendulum shaft (40) swags to touch the retractable slide shaft driving mechanism (30) to drive the slide shaft (31) to slide.

[0008] In another preferred embodiment, the pendulum shaft (40) is fan shaped, the pendulum shaft (40) swags along the axis of fan, two ends of the arc portion of the fan of the pendulum (40) are respectively protruding with an abutting portion, one abutting portion abuts against the button (20), the other abutting portion abuts against the retractable slide shaft driving mechanism (30).

[0009] In another preferred embodiment, the fixing portion (10) is disposed with a water diversion chamber (14), the water diversion chamber (14) is disposed with two side portions connected to each other and a central portion between the two side portions, the central portion is disposed with a lower opening connected to the two water diversion holes (121), the central portion is connected to the inlet waterway (11);

the slide shaft (31) is disposed with two sealing rings (33) arranged with space along the slide shaft (31), the switch sealing element (32) is disposed between the two sealing rings (33);

two sealing rings (33) are respectively slidably connected to the two side portions of the water diversion chamber (14) in sealing way, the section area of the two sealing rings (33) are equal to make the two sealing rings (33) be pressed by equal water pressure, the switch sealing element (32) is inserted to the lower opening.

[0010] In another preferred embodiment, the fixing portion (10) is disposed with a fitting surface formed with the two water diversion holes (121), the lower opening of the water diversion chamber (14) is faced to the fitting surface, the switch sealing element (32) is slidably connected to the fitting surface in sealing way; the slide shaft (31) is further disposed with a balance sealing seat (34), the

balance sealing seat (34) and the switch sealing element (32) are symmetrical vertically with respect to the slide shaft (31), the balance sealing seat (34) is slidably connected to the top surface of the water diversion chamber (14). In another preferred embodiment, the retractable slide shaft driving mechanism further comprises a slide sleeve (35) connected to the fixing portion (10), a rotating wheel (36) connected to the fixing portion (36), a first spring (37) abutting between the slide sleeve (35) and the rotating wheel (36) and a second spring (38) abutting between the first end of the slide shaft (31) and the fixing portion (10), the second end of the slide shaft (31) abuts against the rotating wheel (36), the button (20) is connected to the slide sleeve (35) in transmission way to drive the slide sleeve (35) to slide, the slide sleeve (35) slides to drive the rotating wheel (37) to rotate to drive the slide shaft (31) to expand and contract with the fitting of the first spring (37) and the second spring (39).

[0011] In another preferred embodiment, the slide shaft (31) comprises a central base (311) and two pushing rods (312) respectively abutting the central base (311), the switch sealing element (32) is disposed at the central base (311).

[0012] In another preferred embodiment, one diversion waterway (12) comprises a water passage (122) connected to the water diversion holes (121), a negative pressure chamber (123) connected to the water passage (122) and an outlet hole connected to the negative pressure chamber (123) disposed at the cover plate component (13) of the fixing portion (10); the negative pressure chamber (123) is connected to an air suction passage, the air suction passage comprises an air inlet disposed at the cover plate component (13) of the fixing portion (10) and a non-return air suction plug (15) connected to the air inlet, the outlet of the non-return air suction plug (15) is connected to the negative pressure chamber (123). Compared to the existing technology, the technical proposal of the present invention has advantages as follows:

1. Two water diversion holes are arranged in a line along the sliding direction of the slide shaft, the slide shaft slides to control the switch sealing element to close one of the two water diversion holes alternatively to achieve switch, the structure is compact, the switch mechanism needs small space, the shower head is small in size.
2. The button is movably assembled to the handle portion or the connecting of the handle portion and the head portion that it is convenient for user to operate.
3. The fixing portion is disposed with a cover plate component, the sliding direction of the slide shaft is parallel to the cover plate component that it makes the shower head thin in the thickness, small in size and attractive in appearance.
4. The button slides to drive the pendulum shaft to swag, the pendulum shaft swags to touch the retract-

able slide shaft driving mechanism to drive the slide shaft to slide, the arrangement is reasonable that it is convenient for user to operate and compact in structure.

5. The pendulum shaft is fan shaped, two ends of the arc portion of fan of the pendulum shaft are respectively protruding with an abutting portion, one abutting portion abuts against the button, the other abutting portion abuts against the retractable slide shaft driving mechanism, it has reasonable arrangement, compact structure and high switch stability.

6. Two sealing rings are respectively slidably connected to the two side portions of the water diversion chamber in sealing way, and two sealing rings have equal section area, so that they are pressed by equal water pressure, the switch sealing element is inserted to the lower opening, two sides of the water diversion chamber are balanced in water pressure, the slide shaft slides without the influence of the water pressure at left and right side.

7. The slide shaft is further disposed with a balance sealing seat, the balance sealing seat and the switch sealing element are vertically symmetrical with respect to the slide shaft, the balance sealing seat is slidably connected to the top surface of the water diversion chamber, the slide shaft slides without the vertical influence of the water pressure.

8. The slide shaft comprises a central base and two pushing rods respectively abutting against the two sides of the central base, the switch sealing element is disposed in the central base that it is convenient to assemble.

9. Negative pressure generates when water flows to the negative chamber from the water passage due to the changing of area, outer air enters the negative chamber from the air inlet through the non-return suction plug under the action of the negative pressure, air and water mix to produce oxygen-enriched bubble water.

Brief description of the drawings

[0013] The present invention will be further described with the drawings and the embodiments.

FIG.1 illustrates a schematic diagram of the shower head.

FIG.2 illustrates a front view of the shower head.

FIG.3 illustrates a sectional diagram of FIG.2 in A-A when water flows out of the first diversion waterway of the shower head.

FIG.4 illustrates a sectional diagram of FIG.2 in A-A when water flows out of the second diversion waterway of the shower head.

FIG.5 illustrates an enlargement diagram of a portion of FIG.4.

FIG.6 illustrates an enlargement diagram of another portion of FIG.4.

Detailed description of the embodiments

[0014] Referring to FIGs 1-6, the double-functional button switch shower head comprises a fixing portion 10, a button 20, a retractable slide shaft driving mechanism 30 and a pendulum shaft 40.

[0015] The fixing portion 10 comprises an inlet waterway 11 and two diversion waterways 12, two diversion waterways 12 are respectively disposed with a water diversion hole 121, two water diversion holes 121 can be connected to the inlet waterway 11. The fixing portion 10 comprises a head portion and a handle portion fastened together, the head portion of the fixing portion 10 is disposed with a cover plate component 11. The button 20 is movably connected to the handle portion of the fixing portion 10 or the connecting of the handle portion and the head portion. The retractable slide shaft driving mechanism 30 is assembled to the fixing portion 10 with a slide shaft 31 slidably connected to the fixing portion 10, the sliding direction of the slide shaft 31 is parallel to the cover plate component 13. The water diversion holes 121 are arranged in a line with space along the sliding direction of the slide shaft 21. The pendulum shaft 40 is connected to the fixing portion in swag way, the button 20 is slidably connected to the fixing portion 10, the button 20 slides to drive the pendulum shaft 40 to swag, the pendulum shaft 40 swags to touch the retractable slide shaft driving mechanism 30 to drive the slide shaft 31 to slide forth and back, the slide shaft 31 is fixedly disposed with a switch sealing element 32, the slide shaft 31 slides to control the switch sealing element 32 to close one of the two water diversion holes 121 alternatively to realize switch.

[0016] In a detailed structure, the pendulum shaft 40 is fan shaped, the pendulum shaft 40 swags along the axis of fan, two ends of the arc portion of fan of the pendulum shaft 40 are respectively protruding with an abutting portion, one abutting portion abuts against the button 20, the other abutting portion abuts against the retractable slide shaft driving mechanism 30 to touch the retractable slide shaft driving mechanism 30.

[0017] In a preferred embodiment, the fixing portion 10 is disposed with a water diversion chamber 14, the water diversion chamber is disposed with two side portions connected to each other and a central portion between the two side portions, the central portion is disposed with a lower opening connected to the two water diversion holes 121, the central portion is connected to the inlet waterway 11; the slide shaft 31 is disposed with two sealing rings 33 arranged with space along the slide shaft 31, the switch sealing element 32 is disposed between the two sealing rings 33; two sealing rings 33 are respectively slidably connected to the two side portions of the water diversion chamber 14 in sealing way, the section area of the two sealing rings 33 are equal to make the two sealing rings 33 be pressed by equal water pressure, the switch sealing element 32 is inserted to the lower opening. The fixing portion 10 is disposed with a fitting surface formed

with the two water diversion holes 121, the lower opening of the water diversion chamber 14 is faced to the fitting surface, the switch sealing element 32 is slidably connected to the fitting surface in sealing way; the slide shaft 31 is further disposed with a balance sealing seat 34, the balance sealing seat 34 and the switch sealing element 32 are symmetrical vertically with respect to the slide shaft 31, the balance sealing seat 34 is slidably connected to the top surface of the water diversion chamber 14 to realize vertical balance of water pressure.

[0018] In a detailed structure, the retractable slide shaft driving mechanism 30 further comprises a slide sleeve 35 connected to the fixing portion 10, a rotating wheel 36 connected to the fixing portion 36, a first spring 37 abutting between the slide sleeve 35 and the rotating wheel 36 and a second spring 38 abutting between the first end of the slide shaft 31 and the fixing portion 10, the second end of the slide shaft 31 abuts against the rotating wheel 36, the button 20 is connected to the slide sleeve 35 in transmission way to drive the slide sleeve 35 to slide, the slide sleeve 35 slides to drive the rotating wheel 37 to rotate to drive the slide shaft 31 to expand and contract with the fitting of the first spring 37 and the second spring 38, the principle of expanding and contracting is applied with the existing retractable slide shaft driving mechanism. That is to say, when the slide sleeve 35 slides once, it drives the rotating wheel 36 to rotate in a certain angle, when the rotating wheel 36 rotates to a high position, the slide shaft moves to the left to make the sealing element 32 close the left water diversion hole; when the rotating wheel 36 rotates to a lower position, the slide shaft 31 moves to the right to make the sealing element 32 move from the left water diversion hole to the right water diversion hole to close the right water diversion hole. Preferred, the slide shaft 31 comprises a central base 311 and two pushing rods 312 respectively abutting the central base 311, the switch sealing element 32 is disposed at the central base 311, the top and bottom surface of the central base 311 are respectively concaved with a position groove, the balance sealing seat 34 and the switch sealing element 32 are respectively assembled in the two position grooves and extended out of the opening of the position groove.

[0019] In a detailed structure: the one diversion waterway 12 comprises a water passage 122 connected to the water diversion holes 121, a negative pressure chamber 123 connected to the water passage 122 and an outlet hole connected to the negative pressure chamber 123 disposed at the cover plate component 13 of the fixing portion 10; the negative pressure chamber 123 is connected to an air suction passage, the air suction passage comprises an air inlet disposed at the cover plate component 13 of the fixing portion 10 and a non-return air suction plug 15 connected to the air inlet, the outlet of the non-return air suction plug 15 is connected to the negative pressure chamber 123. The water passage 122 is, for example, an incline water slot.

[0020] In this embodiment, the fixing portion 10 com-

prises a main body 16, a cover plate component 13, a fixing seat component 18, a top cover 19 and a spindle component 17. The main body 16 is disposed with the handle portion 161 and a decoration cover 162 fastened together. The top cover 19 is fixedly connected to the decoration cover 162 and an assembly chamber is formed therebetween. The cover plate component 13 is assembled to the assembly chamber, the cover plate component 13 is disposed with above mentioned two diversion waterways 12, the top surface of the cover plate component 13 is the fitting surface, the water diversion holes of the two diversion waterways 12 are disposed in the fitting surface. The cover plate component 13 has two water types, for example, one is bubble water and the other is shower water. The fixing seat component 18 is fixedly connected to the cover plate component 13, two sealing covers 181 are fixedly connected to the two ends of the fixing seat component 18 to form above mention water diversion chamber, the retractable slide shaft driving mechanism passes through the fixing seat component 18, the slide sleeve of the retractable slide shaft driving mechanism slidably passes through one sealing cover in sealing way to connect to the pendulum shaft in transmission way. The spindle component 17 is assembled in the handle portion to deflect the water resource into the shower head.

[0021] The present invention may be summarized as follows: The present invention is provided with a double-functional button switch shower head, which comprises a fixing portion, a button and a retractable slide shaft driving mechanism. The fixing portion is disposed with an inlet waterway and two diversion waterways, two diversion waterways are respectively disposed with an water diversion hole, two water diversion holes can be connected to the inlet waterway. The button is movably connected to the fixing portion. The retractable slide shaft driving mechanism is assembled in the fixing portion with a slide shaft slidably connected to the fixing portion, the button is connected to the retractable slide shaft driving mechanism in transmission way to drive the slide shaft to slide; two water diversion holes are arranged in a line along the sliding direction of the slide shaft; the slide shaft is disposed with a switch sealing element, the slide shaft slides to control the switch sealing element to close one of the two water diversion holes alternatively to achieve switch. The present invention has advantages: the structure is compact, the switch mechanism needs small space, the shower head is small in size.

[0022] Although the present invention has been described with reference to the preferred embodiments thereof for carrying out the patent for invention, it is apparent to those skilled in the art that a variety of modifications and changes may be made without departing from the scope of the patent for invention which is intended to be defined by the appended claims.

Claims

1. Double-functional button switch shower head, comprising:

5 a fixing portion (10) and an inlet waterway (11) and two diversion waterways (12), two diversion waterways (12) are respectively disposed with a water diversion hole (121), two water diversion holes (121) are available to connect to the inlet waterway (11);
 10 a button (20) movably connected to the fixing portion (10);
 15 a retractable slide shaft driving mechanism (30) assembled to the fixing portion (10), the retractable slide shaft driving mechanism (30) is slidably connected to a slide shaft (31) of the fixing portion (10),
 20 the button (20) is connected to the retractable slide shaft driving mechanism (30) in transmission way to drive the slide shaft (31) to slide;
 25 wherein two water diversion holes (121) are parallel arranged in a line with space along the sliding direction of the slide shaft; the slide shaft (31) is disposed with a switch sealing element (32), the slide shaft (31) slides to control the switch sealing element (32) to close one of the two water diversion holes (121) alternatively to realize switch.

2. The double-functional button switch shower head according to claim 1, wherein the fixing portion (10) comprises a head portion and a handle portion fastened together, the button (20) is movably disposed to the handle portion or the connecting of the handle portion and the head portion.

3. The double-functional button switch shower head according to claim 1 and/or 2, wherein the fixing portion (10) is disposed with a cover plate component (13), the sliding direction of the slide shaft (31) is parallel to the cover plate component (13).

4. The double-functional button switch shower head according to any one or more of the preceding claims, wherein a pendulum shaft (40) is further provided, the pendulum shaft (40) is connected to the fixing portion (10) in swag way, the button (20) is connected to the fixing portion (10) in sliding way, the button (20) slides to drive the pendulum shaft (40) to swag, the pendulum shaft (40) swags to touch the retractable slide shaft driving mechanism (30) to drive the slide shaft (31) to slide.

5. The double-functional button switch shower head according to claim 4, wherein the pendulum shaft (40) is fan shaped, the pendulum shaft (40) swags along the axis of fan, two ends of the arc portion of

the fan of the pendulum (40) are respectively protruding with an abutting portion, one abutting portion abuts against the button (20), the other abutting portion abuts against the retractable slide shaft driving mechanism (30).

6. The double-functional button switch shower head according to any one or more of the preceding claims, in particular, according to any one or more of claims 1 to 3, wherein:

the fixing portion (10) is disposed with a water diversion chamber (14), the water diversion chamber (14) is disposed with two side portions connected to each other and a central portion between the two side portions, the central portion is disposed with a lower opening connected to the two water diversion holes (121), the central portion is connected to the inlet waterway (11);

the slide shaft (31) is disposed with two sealing rings (33) arranged with space along the slide shaft (31), the switch sealing element (32) is disposed between the two sealing rings (33);

two sealing rings (33) are respectively slidably connected to the two side portions of the water diversion chamber (14) in sealing way,

the section area of the two sealing rings (33) are equal to make the two sealing rings (33) be pressed by equal water pressure, the switch sealing element (32) is inserted to the lower opening.

7. The double-functional button switch shower head according to any one or more of the preceding claims, in particular, according to claim 6, wherein the fixing portion (10) is disposed with a fitting surface formed with the two water diversion holes (121), the lower opening of the water diversion chamber (14) is faced to the fitting surface, the switch sealing element (32) is slidably connected to the fitting surface in sealing way; the slide shaft (31) is further disposed with a balance sealing seat (34), the balance sealing seat (34) and the switch sealing element (32) are symmetrical vertically with respect to the slide shaft (31), the balance sealing seat (34) is slidably connected to the top surface of the water diversion chamber (14).

8. The double-functional switch shower head according to any one or more of the preceding claims, in particular, according to any one or more of claims 1 to 3, wherein the retractable slide shaft driving mechanism further comprises a slide sleeve (35) connected to the fixing portion (10), a rotating wheel (36) connected to the fixing portion (36), a first spring (37) abutting between the slide sleeve (35) and the rotating wheel (36) and a second spring (38) abutting between the first end of the slide shaft (31) and the fixing portion (10), the second end of the slide shaft (31) abuts against the rotating wheel (36), the button

(20) is connected to the slide sleeve (35) in transmission way to drive the slide sleeve (35) to slide, the slide sleeve (35) slides to drive the rotating wheel (37) to rotate to drive the slide shaft (31) to expand and contract with the fitting of the first spring (37) and the second spring (39).

9. The double-functional switch shower head according to any one or more of the preceding claims, in particular, according to claim 8, wherein the slide shaft (31) comprises a central base (311) and two pushing rods (312) respectively abutting the central base (311), the switch sealing element (32) is disposed at the central base (311).

10. The double-functional switch shower head according to any one or more of the preceding claims, in particular, according to any one or more of claims 1 to 3, wherein one diversion waterway (12) comprises a water passage (122) connected to the water diversion holes (121), a negative pressure chamber (123) connected to the water passage (122) and an outlet hole connected to the negative pressure chamber (123) disposed at the cover plate component (13) of the fixing portion (10); the negative pressure chamber (123) is connected to an air suction passage, the air suction passage comprises an air inlet disposed at the cover plate component (13) of the fixing portion (10) and a non-return air suction plug (15) connected to the air inlet, the outlet of the non-return air suction plug (15) is connected to the negative pressure chamber (123).

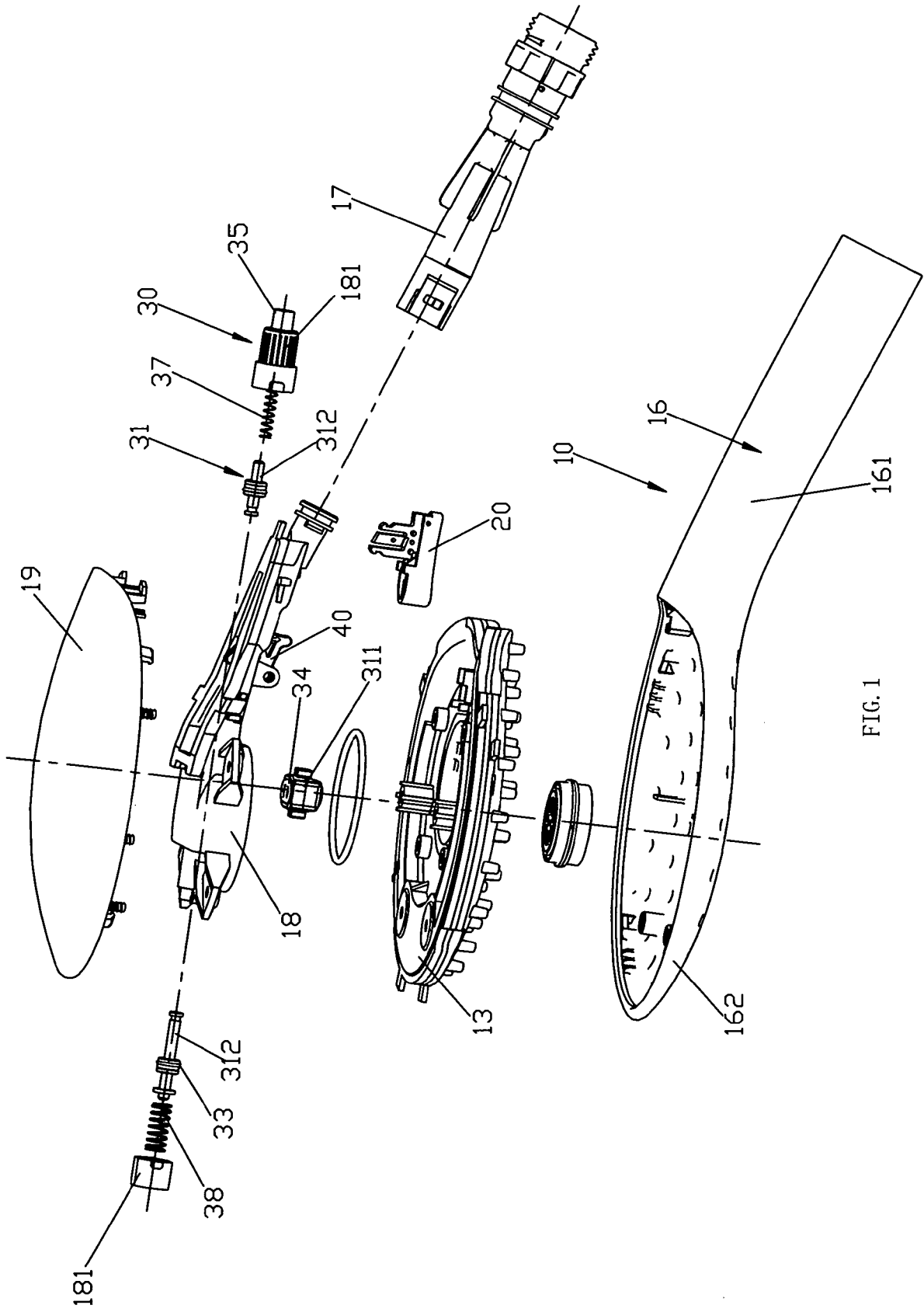

FIG. 1

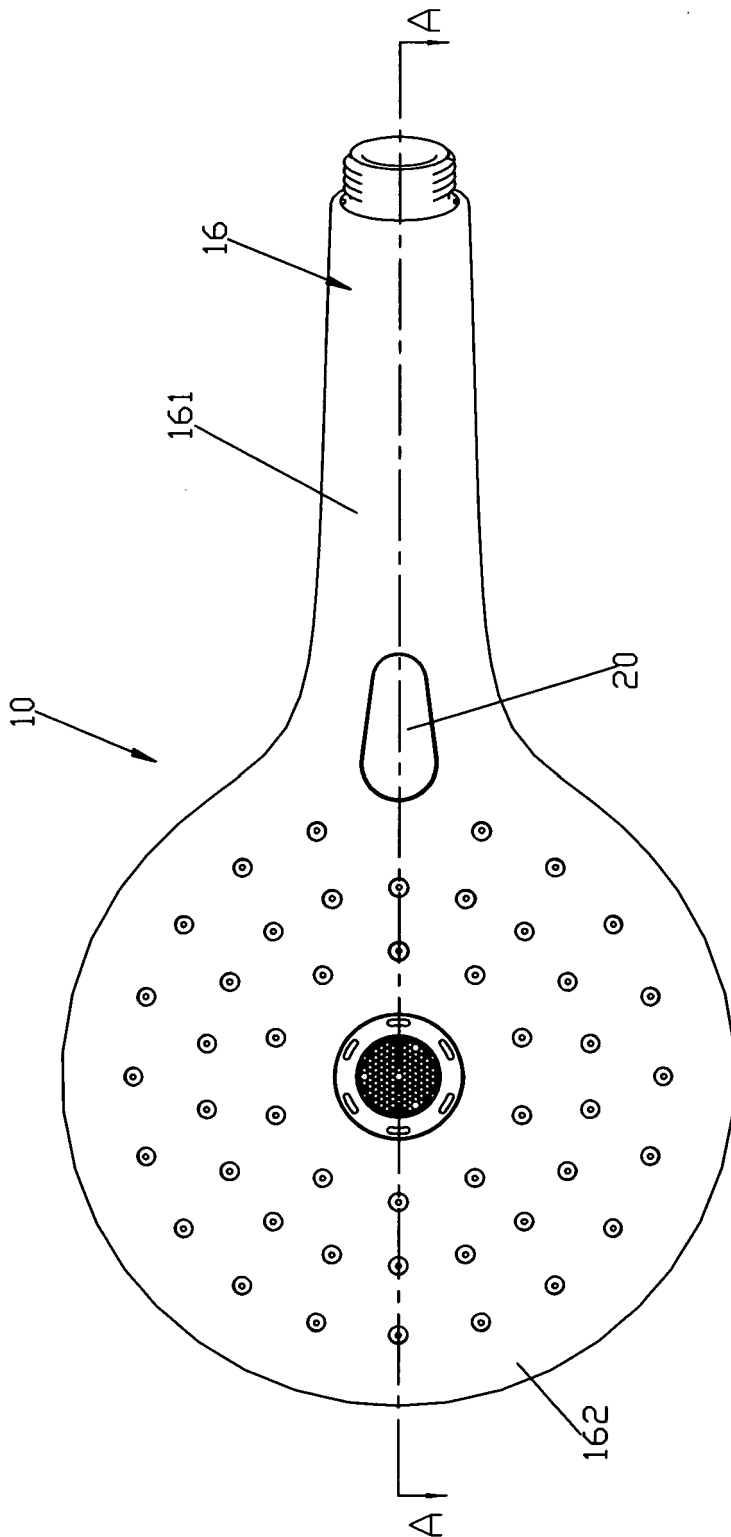

FIG. 2

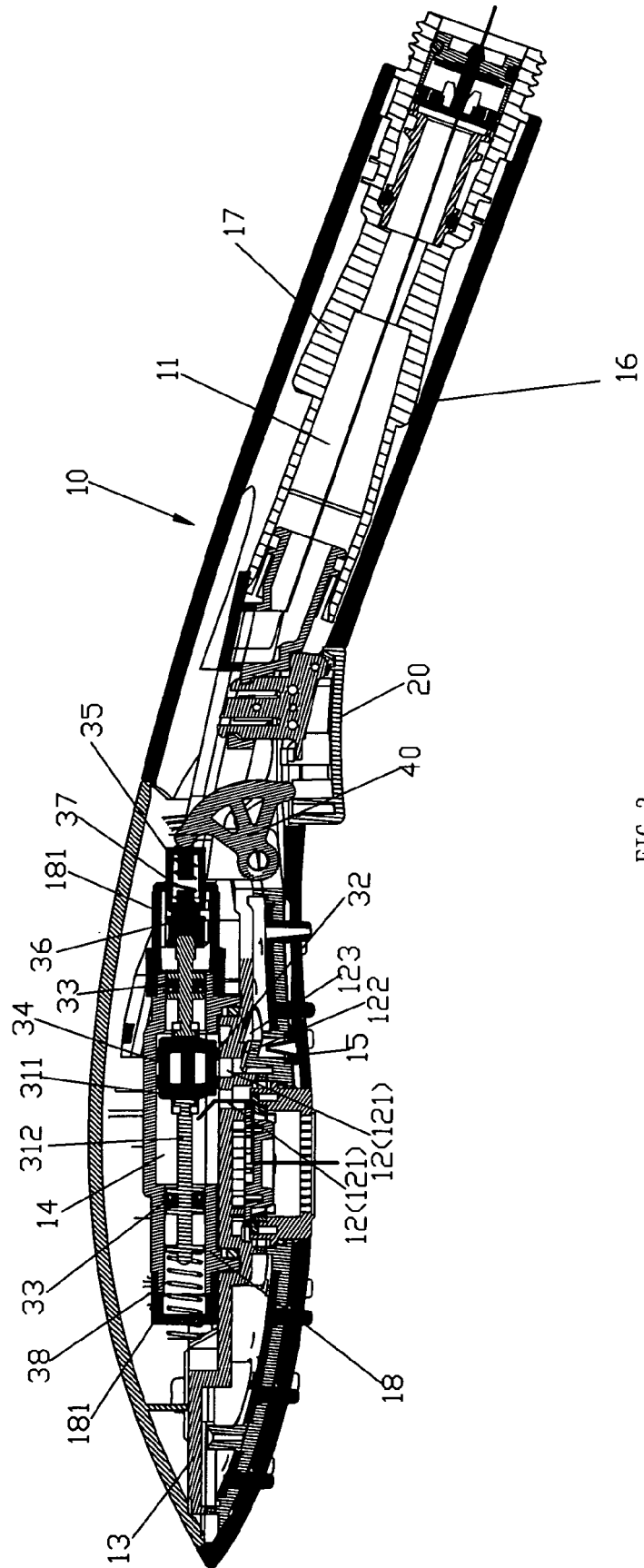

FIG. 3

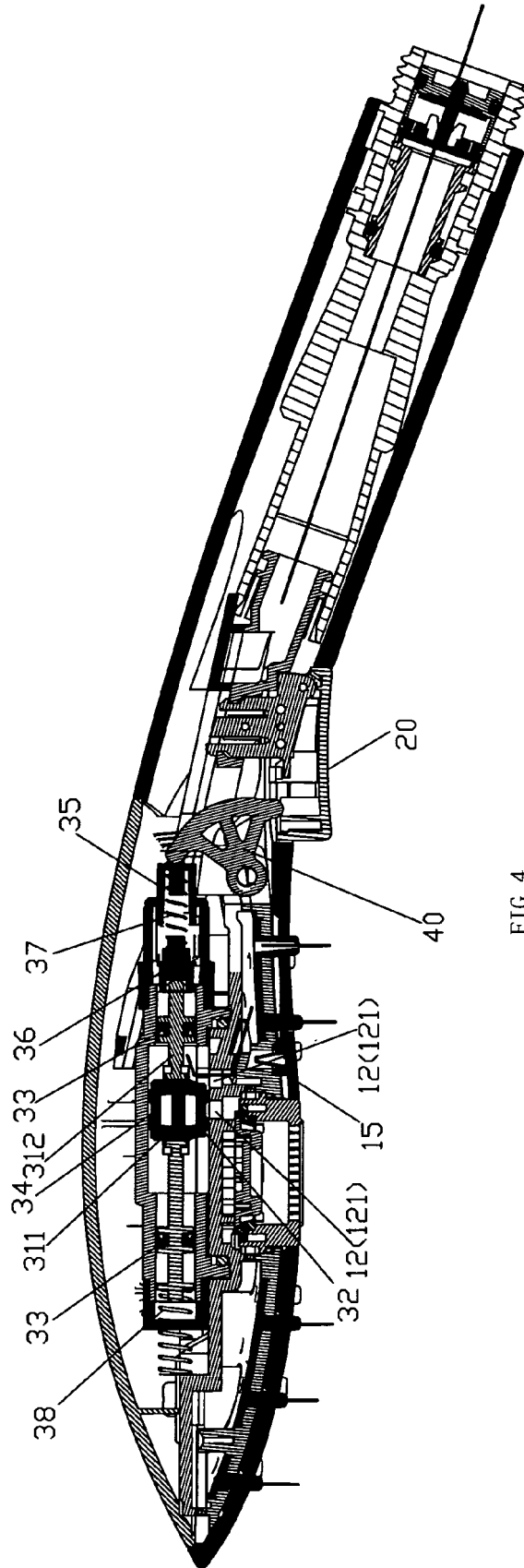

FIG. 4

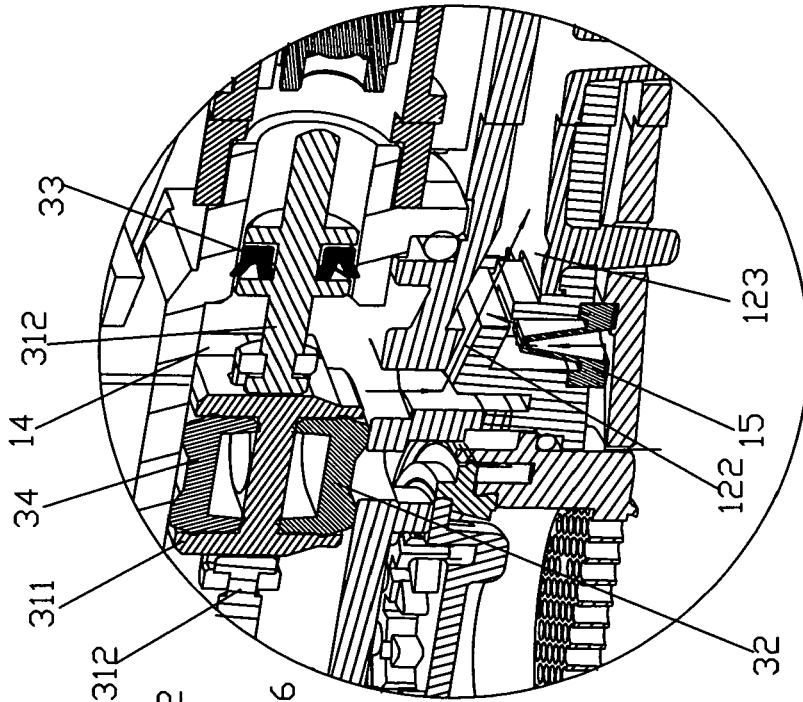

FIG.6

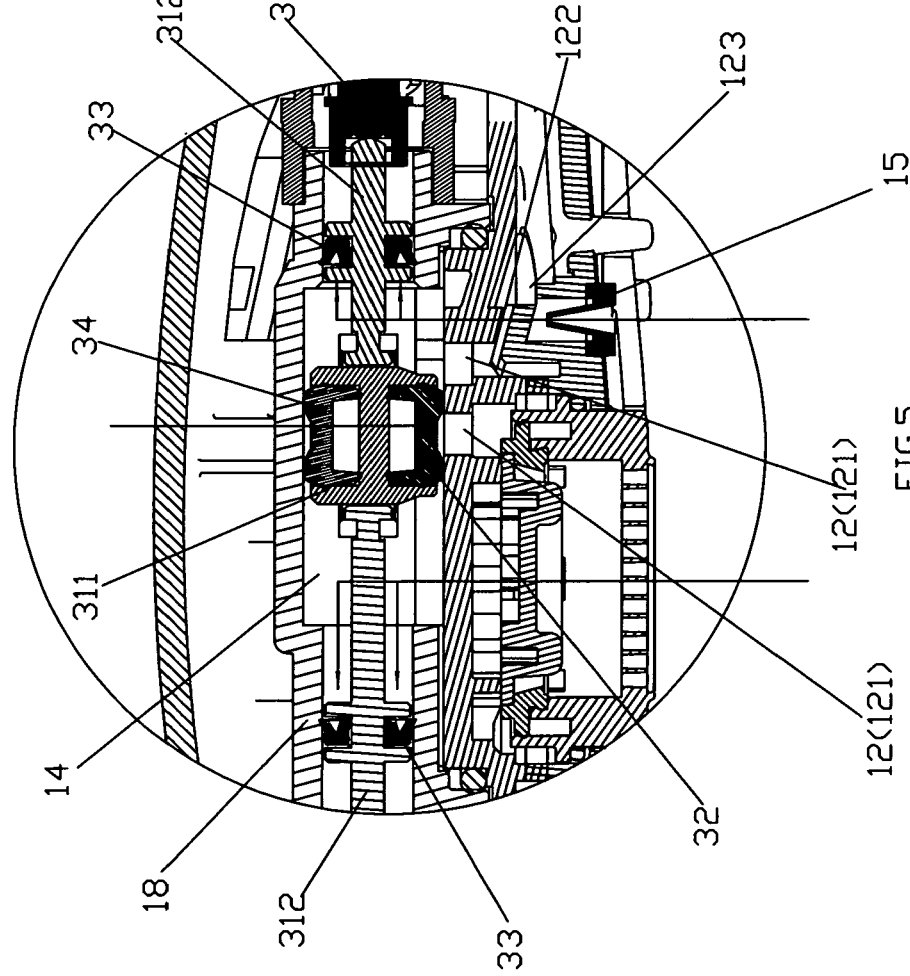

FIG.5



EUROPEAN SEARCH REPORT

Application Number
EP 16 00 1374

5

10

15

20

25

30

35

40

45

50

55

DOCUMENTS CONSIDERED TO BE RELEVANT			
Category	Citation of document with indication, where appropriate, of relevant passages	Relevant to claim	CLASSIFICATION OF THE APPLICATION (IPC)
X	US 2015/115065 A1 (LIN FENGDE [CN] ET AL) 30 April 2015 (2015-04-30)	1,6,7,9	INV. B05B1/16 B05B1/18 B05B7/04
Y	* abstract; figures 1-3 *	2,3,10	
A	* page 1, paragraph 4 - paragraph 19 * * page 2, paragraph 24 - paragraph 37 *	4,5,8	
Y	WO 2014/121693 A1 (XIAMEN SOLEX HIGH TECH IND CO [CN]; ZHOU HUASONG [CN]) 14 August 2014 (2014-08-14) * abstract; figures 1-9 *	2,3	
Y	JP 2010 284619 A (FUKUSHIMA KAGAKU KK) 24 December 2010 (2010-12-24) * paragraph [0058] *	10	
The present search report has been drawn up for all claims			
Place of search Munich		Date of completion of the search 8 November 2016	Examiner Frego, Maria Chiara
CATEGORY OF CITED DOCUMENTS X : particularly relevant if taken alone Y : particularly relevant if combined with another document of the same category A : technological background O : non-written disclosure P : intermediate document		T : theory or principle underlying the invention E : earlier patent document, but published on, or after the filing date D : document cited in the application L : document cited for other reasons & : member of the same patent family, corresponding document	

EPO FORM 1503 03/02 (P04C01)

ANNEX TO THE EUROPEAN SEARCH REPORT
ON EUROPEAN PATENT APPLICATION NO.

EP 16 00 1374

5

This annex lists the patent family members relating to the patent documents cited in the above-mentioned European search report. The members are as contained in the European Patent Office EDP file on The European Patent Office is in no way liable for these particulars which are merely given for the purpose of information.

08-11-2016

10

Patent document cited in search report	Publication date	Patent family member(s)	Publication date
US 2015115065 A1	30-04-2015	CN 103521370 A US 2015115065 A1	22-01-2014 30-04-2015
-----	-----	-----	-----
WO 2014121693 A1	14-08-2014	CN 103962254 A WO 2014121693 A1	06-08-2014 14-08-2014
-----	-----	-----	-----
JP 2010284619 A	24-12-2010	JP 4933582 B2 JP 2010284619 A	16-05-2012 24-12-2010
-----	-----	-----	-----

15

20

25

30

35

40

45

50

55

EPO FORM P0459

For more details about this annex : see Official Journal of the European Patent Office, No. 12/82

REFERENCES CITED IN THE DESCRIPTION

This list of references cited by the applicant is for the reader's convenience only. It does not form part of the European patent document. Even though great care has been taken in compiling the references, errors or omissions cannot be excluded and the EPO disclaims all liability in this regard.

Patent documents cited in the description

- CN 201831744 U [0002]