



(11) **EP 3 116 803 B2**

(12) **NEW EUROPEAN PATENT SPECIFICATION**
After opposition procedure

- (45) Date of publication and mention of the opposition decision: **12.10.2022 Bulletin 2022/41**
- (45) Mention of the grant of the patent: **25.04.2018 Bulletin 2018/17**
- (21) Application number: **15710561.0**
- (22) Date of filing: **10.03.2015**
- (51) International Patent Classification (IPC):
B65D 85/804^(2006.01)
- (52) Cooperative Patent Classification (CPC):
B65D 75/5883; B65D 85/8061
- (86) International application number:
PCT/GB2015/050696
- (87) International publication number:
WO 2015/136267 (17.09.2015 Gazette 2015/37)

(54) **BEVERAGE PREPARATION CAPSULES**
GETRÄNKEZUBEREITUNGSKAPSELN
CAPSULES DE PRÉPARATION DE BOISSON

-
- | | |
|--|---|
| <p>(84) Designated Contracting States:
AL AT BE BG CH CY CZ DE DK EE ES FI FR GB GR HR HU IE IS IT LI LT LU LV MC MK MT NL NO PL PT RO RS SE SI SK SM TR</p> <p>(30) Priority: 11.03.2014 GB 201404290
03.12.2014 GB 201421494</p> <p>(43) Date of publication of application:
18.01.2017 Bulletin 2017/03</p> <p>(73) Proprietor: Lavazza Professional Germany GmbH
27283 Verden (DE)</p> <p>(72) Inventor: WICKS, David
Basingstoke
Hampshire RG24 8NU (GB)</p> | <p>(74) Representative: Bosch Jehle
Patentanwaltsgesellschaft mbH
Flüggenstraße 13
80639 München (DE)</p> <p>(56) References cited:
EP-A1- 0 468 079 EP-A1- 2 100 824
EP-A1- 2 487 122 EP-A1- 2 730 523
EP-A2- 0 179 641 WO-A1-2005/026018
WO-A1-2013/053757 WO-A2-2011/031294
FR-A1- 2 527 173 GB-A- 2 406 305
US-A1- 2013 243 910</p> |
|--|---|

EP 3 116 803 B2

Description

[0001] The present invention relates to beverage preparation capsules.

A number of beverage-making systems are known in which a single serving of the beverage is made by inserting a capsule containing a particulate beverage-making ingredient, such as ground coffee, into a beverage-making station of a beverage-making apparatus. The apparatus then injects water into the capsule, where the beverage-making ingredient dissolves in, or infuses into, the water to form the beverage. The beverage flows out of the capsule through a suitable outlet, which may be simply an opening or perforation in the capsule or it may comprise an outlet tube that pierces an outlet region of the capsule. The capsule may incorporate a filter to prevent passage of solid components such as coffee grounds out of the capsule. Beverage-making systems of this general type are described for example in WO 94/01344, EP-A-0512468 and EP-A-0468079 (all Nestle), in U.S. Pat. No. 5,840,189 (Keurig), in EP-A-0272922 (Kenco), in EP-A-0821906 (Sara Lee) and in EP-A-0179641 and WO-A-02/19875 (Mars).

EP2100824A1 concerns a capsule for use in a beverage production machine comprising a base body, a foil member tightly attached to the base body, and a flow control porous member positioned between at least a portion of the ingredients and the foil member. EP2487122A1 concerns a beverage capsule including a body having a side-wall and a base defining an interior space. A first opening is defined at one end of the body and a second opening is defined at an opposing end of the body. A first cover covers the first opening and a second cover covers the second opening. A filter is disposed in the interior space a pre-determined distance away from the second opening. US2013/243910A1 concerns a portion capsule for producing a beverage having a capsule body with a capsule base and a filling side. A cavity for accommodating a pulverulent or liquid beverage base is formed between the capsule base and the filling side, and a filter element is arranged between the beverage base and the capsule base.

GB-A-2121762, GB-A-2122881, EP-A-0179641, EP-A-0247841 and WO-A-9905044 describe capsule-based beverage preparation systems of the type that are now widely used and marketed by Mars Drinks under the registered trade mark FLAVIA. An exemplary embodiment of a FLAVIA capsule according to the state of the art is shown in Figures 1, 2a and 2b.

[0002] Referring to Figures 1, 2a and 2b, the current FLAVIA-type beverage preparation capsule 100 comprises front and back sheets 110, 112 of a liquid- and air-impermeable sheet material permanently bonded together around their top and side edges as described in more detail below. The front and back sheets are also bonded together along a bottom edge 120 of the capsule, but this bond is releasable under the effect of heat or pressure inside the capsule. For example, the bonding of the bot-

tom edge 120 may be by means of a pressure-sensitive adhesive. Within the capsule 100 is a folded web of filter material 130 bonded to the inside walls of the front and back sheets. The web of filter material that supports a beverage preparation ingredient 150, such as ground coffee or leaf tea. The capsule 100 further comprises a nozzle 140 having tubular bore 142. The nozzle is inserted into the top edge of the capsule and bonded in an airtight fashion to the front and back sheets, the nozzle being flanged to assist in locating the capsule 100 correctly with a beverage preparation machine. The nozzle bore is initially sealed by a suitable airtight freshness barrier.

[0003] Referring to Figure 2a, the sheet of web material 130 is folded to form a "W"-shape in cross-section supporting the infusible beverage preparation ingredient 150. Upon introduction of liquid through the liquid conduct, the liquid pressure causes the apex 132 of the W to evert to provide a downwardly convex filter bed as shown in Figure 2b. The eversion effect assists in the rupture of the pressure-sensitive seal of the bottom seam 120 to dispense a beverage brewed in the capsule. Further details of the everting filter webs may be found in EP-A-0179641.

[0004] Beverage-making capsules of the above type have found widespread use. However, they suffer from certain drawbacks. The manufacture of these capsules requires assembly of appropriately shaped components in a precise and secure manner, which increases manufacturing costs. Moreover, the rate of flow of the beverage through the ingredient and filter sheet may not be as fast and/or as uniform as would be desirable for optimum beverage preparation. A difficulty that can arise with the above systems is incomplete dissolution or extraction of the beverage ingredients inside the capsule. For example, channelling of liquid through the compressed bed of beverage preparation ingredient during brewing may occur when preparing beverages using capsule-based systems, especially where relatively high pressures are required such as in the preparation of espresso and espresso-type beverages. This channelling directs the liquid through preferred pathways in the compressed bed of beverage preparation ingredient preventing uniform exposure of the beverage preparation ingredient to the liquid. This can result in wasted beverage preparation ingredient and a beverage having reduced concentration of dissolved or infused material. Channelling may also occur if the beverage preparation ingredient is not uniformly distributed. Another difficulty that can arise is excessive system back-pressure due to blocking or partial obstruction of water flow in regions where the particulate ingredient is more dense or tightly packed, such as at the bottom regions of the filter.

[0005] The above problems can all lead to inconsistent vending performance and poor beverage taste. Attempts have been made to solve the above problems. WO-A-2005026018 describes a beverage capsule in which a filter element has a flat base and fluted sides to improve

flow of liquid through the filter and the beverage ingredient.

[0006] However, a need still remains for improved beverage preparation capsules, suitably but not exclusively for use in equipment of the FLAVIA type.

[0007] The present invention provides a beverage preparation capsule comprising a hollow body suitable for containing a beverage preparation ingredient, the hollow body having a top end for receiving liquid into the hollow body, a bottom end for dispensing the beverage from the hollow body, and at least one side wall between the top and bottom ends, the bottom end being in fluid communication with the top end; and the hollow body containing a filter material having a variable porosity along at least one dimension of the filter material's surface area, wherein the filter material is less porous closer to the top or inlet of the hollow body and more porous closer to the bottom or outlet of the hollow body, or wherein the filter material is less porous closer to the side wall of the hollow body and more porous closer to the centre of the filter material, or a combination of both. In use, the top end receives liquid into the hollow body for contacting with a beverage preparation ingredient.

[0008] In this way, the pressure drop (Δ -P) from the top end to the bottom end of the hollow body can be similar or the same across the whole filter material, in order to encourage consistent flow of liquid through the entire beverage material, and substantially avoid liquid channelling through a passage of least resistance, such that substantially all of the beverage material is contacted with liquid. This is especially useful where different areas of the filter material support different amounts of beverage ingredient.

[0009] For example, in areas of the filter material where water must pass through larger amounts of beverage ingredient (such as lower portions of the filter material) the porosity of the filter material can be greater, and areas where water must pass through lesser amounts of beverage ingredient (such as higher portions of the filter material) the porosity of the filter material can be less. This encourages consistent flow of liquid through all areas of the filter material.

[0010] Providing a more porous region towards the centre of the filter material, with less porous regions near the side walls of the capsule, is useful to reduce the tendency of liquid to preferentially follow near the side walls of the pod and bypass some of the beverage preparation ingredient.

[0011] The variable porosity of the filter material may be provided by a thickness, pore size, pore density or composition which varies across the surface area of the filter material. Preferably, the porosity is varied by a distribution of different pore sizes or pore density.

[0012] The dimension of the filter material which has a variable porosity may extend between a first position relatively closer to the top end of the hollow body and a second position relatively closer to the bottom end of the hollow body. Preferably, the filter material is less porous

closer to the top or inlet of the hollow body and more porous closer to the bottom or outlet of the hollow body. In this way, the pressure drop from the top end to the bottom end of the hollow body can be similar or the same across the whole filter material, even though lower areas of the filter material may support larger quantities of beverage ingredient.

[0013] Conveniently, the filter material is a sheet of filter material and may be presented in various arrangements. The sheet of filter material extends across the inside of the hollow body at an incline relative to the side wall, where the sheet of filter material extends directly from a first position on a side wall to a second position on a side wall, wherein said first position is relatively closer to the top end of the hollow body and the second position is relatively closer to the bottom end of the hollow body. It will be appreciated that this inclined arrangement of the filter material is particularly useful to achieve the embodiment of the invention in which the filter material is less porous closer to the top or inlet of the hollow body and more porous closer to the bottom or outlet of the hollow body. Preferably, the porosity of the filter material varies across the dimension which extends across the inside of the hollow body from one side wall to another. In this way, the porosity of the filter material may increase from the first position relatively closer to the top end of the hollow body towards the second position relatively closer to the bottom end of the hollow body, preferably wherein the porosity of the filter material increases by a gradation of porosities. Preferably, the sheet of filter material is a single sheet of non-folded material, in that the filter material extending across the inside (cavity) of the hollow body is not folded.

[0014] In this way, several advantages are provided, namely: easier construction of the capsule in manufacture; less construction material required, particularly less filter material; more consistent vending performance; and more consistent drink taste. Specifically, by inclining the filter material inside the hollow body of the capsule, the surface area of the filter and the liquid contact area of the beverage preparation ingredient resting upon the filter is maximised, without the need for the multiple layers or complicated folding arrangements of filter material used in the prior art. This also allows for a convenient arrangement of the filter material having a variable porosity, in that the inclined filter material becomes less porous as it rises towards the top of the hollow body. Preferably, the surface area of the filter material is greater than the transverse cross-sectional area of the cavity of the hollow body. Preferably, the sheet of filter material is a single sheet of non-folded material, in that the filter material extending across the inside (cavity) of the hollow body is not folded. However, it will be appreciated that the edges of the sheet of filter material may be folded to assist in securing of the filter material to the capsule. By avoiding the need for multiple layers and complicated folding arrangements of the filter material, the construction complexity of the capsule is minimised. Furthermore,

the greater contact area of the beverage preparation ingredient with liquid allows for more complete brewing of the beverage preparation ingredient in a shorter time, with reduced channelling of liquid such that fewer regions of beverage preparation ingredient are left unexposed to liquid and wasted. This provides more consistent and improved vending performance and drink taste.

[0015] In one embodiment of the invention, the peripheral edges of the sheet of filter material are secured to the side wall or walls of the hollow body. More preferably, the filter material is secured to the side wall or walls of the hollow body continuously around substantially the whole periphery of the sheet, and most preferably continuously around the whole periphery of the sheet.

[0016] In another embodiment of the invention, the sheet of filter material is formed from one or more side walls of the hollow body. In this case, a filter region of a side wall is perforated such that the side wall becomes at least partially porous in the filter region. The sheet of filter material will therefore comprise the same material as one or more side walls of the hollow body, but may additionally comprise a layer of non-woven filter material laminated to the filter region of the side wall.

[0017] Preferably, the sheet of filter material divides the hollow body into an inlet chamber for receiving liquid and an outlet chamber from which the beverage is dispensed.

[0018] The hollow body may comprise a liquid inlet through which liquid can enter the hollow body. The inlet is preferably located in the top end or a top end region side wall of the hollow body. The inlet is preferably a nozzle having a bore. The bore may be sealed by a frangible freshness barrier before use. For example, the freshness barrier may comprise an oxygen-impermeable membrane of metal foil and/or thermoplastic film extending across the bore of the nozzle. The aforementioned features relating to an inlet are particularly preferred for the sachet capsule embodiment of the present invention, which will be discussed in greater detail below.

[0019] Alternatively, the top end of the hollow body may be without an inlet, but the hollow body may be cut open or pierced in use, to allow delivery of liquid into the hollow body. This feature is particularly preferred for the pod capsule embodiment of the present invention, which will be discussed in greater detail below.

[0020] Preferably, the hollow body comprises an outlet through which beverage can exit the hollow body. Preferably, the bottom end or bottom end region side wall of the hollow body comprises an outlet channel. The outlet channel may be sealed in any convenient way with a seal that can be broken during beverage preparation to allow escape of the beverage through the outlet channel. Conveniently, the seal is formed with a heat- and/or pressure-releasable bond, which may be broken when a fluid medium such as air or water is introduced into the hollow body. The aforementioned features relating to an outlet are particularly preferred for the sachet capsule embodiment of the present invention, which will be discussed

in greater detail below.

[0021] Alternatively, the bottom end of the hollow body may be without an outlet, but the hollow body may be cut open or pierced in use, to allow escape of beverage. This feature is particularly preferred for the pod capsule embodiment of the present invention, which will be discussed in greater detail below.

[0022] Preferably, the beverage preparation capsule comprises a beverage preparation ingredient supported on the filter material between the filter material and the top end of the hollow body. The beverage preparation ingredient may be an infusible beverage ingredient, for example ground coffee or leaf tea. Preferably, the beverage preparation ingredient resides in an inlet chamber of the capsule, as previously described. Preferably, the beverage preparation ingredient is hermetically sealed in the capsule body. That is to say, the hollow body defines an enclosure that encloses the beverage preparation ingredient in substantially air- and liquid-tight fashion until the top end of the hollow body is ruptured in use to inject water into the enclosure through an inlet or piercing to prepare a beverage from the ingredient inside the enclosure, and to allow the thus-prepared beverage to escape from an outlet or piercing created in the bottom end of the hollow body during beverage preparation.

[0023] Preferably, the filter material comprises a web material or a nonwoven fabric material. Where the beverage preparation ingredient is an infusion-type beverage intended to be retained in the capsule after infusion (e.g. ground coffee or leaf tea), the filter material preferably has a sufficiently fine mesh size to retain the infused solids while allowing free passage of the liquid beverage. An exemplary filter material is a laminate of melt blown polypropylene sandwiched between layers of non-woven spun-bonded polypropylene. It can also be desirable to use cellulosic material for reasons of cost and biodegradability. Where the beverage preparation ingredient is a dispersion- or dissolution-type beverage and the whole contents of the capsule are intended to be dispensed, the filter material is preferably a relatively coarse mesh material to allow the beverage ingredient to escape. Nonetheless, the filter material should still prevent rapid escape of a large proportion of the dispersible ingredient, so as to leave the pack as a liquid dispersion rather than as undispersed particles. Moreover, before use and during storage, the majority of the dispersible material should remain on the upper side of the coarse filter material, i.e. between the surface of the filter material and the top end of the hollow body.

[0024] Suitably, the capsule is a single-serve capsule that contains sufficient beverage preparation ingredients for the preparation of a single portion of beverage, i.e. from about 25 ml to about 500 ml, preferably from about 100 ml to about 250 ml of beverage.

[0025] For example, the capsule may contain from about 2 g to about 25 g of ground coffee or from about 1 g to about 9 g of leaf tea, or from about 2 g to about 30

g of water-dispersible ingredients.

[0026] In one embodiment of the present invention, the hollow body is in the form of a sachet comprising front and back sheets of flexible film material arranged in face-to-face relationship and sealed along their edges, wherein the filter material extends from the front sheet of the hollow body to the back sheet of the hollow body.

[0027] The front and back sheets of the sachet embodiment may be laminate sheets, which are preferably air- and water-impermeable.

[0028] Preferably, the sheets of the sachet embodiment are permanently bonded together along lateral edge seams and a top seam, with an outlet region being provided in a bottom seam of the sachet, and wherein a liquid injection nozzle is inserted into the top seam or an edge seam of the sachet. In these embodiments, the construction of the sachet is substantially the same as for a conventional FLAVIA capsule as described above, but with addition of the variable porosity filter material.

[0029] The variable porosity filter material of the sachet embodiment extends from a first position on one sheet of the sachet, wherein the first position is relatively closer to the inlet nozzle, to a second position on the opposite sheet, wherein the second position is relatively closer to the outlet region.

[0030] In one embodiment of the sachet, the sheet of filter material is a distinct piece of material from the front and back sheets of flexible film material and the peripheral edges of the sheet of filter material are secured to the front and back sheets.

[0031] In another embodiment of the sachet, the sheet of filter material is formed from either or both of the front or back sheets of flexible film material. In this case, a filter region of the flexible film material is perforated such that the material becomes at least partially porous in the filter region. For example, a single sheet of flexible film material may be folded into a "N" or "I" shape, such that a first terminal portion of the sheet forms the front of the capsule, an intermediate inclined portion of the sheet is perforated and functions as a filter material, and a second terminal portion of the sheet forms the back of the capsule. In another example, a first sheet of flexible film material may be folded into a "V" or "Λ" shape, such that a first portion of the first sheet forms the front of the capsule, and a second portion of the first sheet is perforated and functions as a filter material. The back of the capsule is formed from a second sheet of flexible film material connected to the liquid permeable portion of the first sheet. In this way, a complete capsule can be provided using only one or two sheets of flexible film material for easier and cheaper construction. In either case, the liquid-permeable portion of the sheet may be laser perforated and may or may not be combined with a laminated layer of non-woven filter material.

[0032] Preferably, the variable porosity filter material is less porous closer to the top or inlet of the sachet and more porous closer to the bottom or outlet of the sachet.

[0033] The outlet region of the sachet embodiment may be sealed in any convenient way with a seal that can be broken during beverage preparation to allow escape of the beverage through the outlet region. Conveniently, the seal is formed by bonding together the front and back sheets with a heat- and/or pressure-releasable bond.

[0034] In certain embodiments, the hollow body of the sachet embodiment may be formed from a single sheet in the form of a tube having an outlet region at one end thereof. The tube may be formed by extrusion, or it may be formed from a single sheet by folding the sheet over and bonding opposed edges thereof along a longitudinal lap or fin seal.

[0035] The materials used to form the hollow body of the sachet embodiment may suitably consist essentially of flexible film materials, for example of the type used to form existing FLAVIA capsules. The flexible film material will usually be a laminate sheet comprising two or more of the following layers: a thermoplastic sealant layer for bonding the hollow body to other members of the capsule; a substantially gas-impermeable barrier layer, which may be a metal film such as aluminium film or a gas-barrier polymer such as polyvinyl alcohol (PvOH); adhesion layers to improve adhesion between other layers of the laminate; structural layers, for example to provide puncture resistance; and/or a printing substrate layer. The structural layers could be made of polyolefins, polyester, nylons, or other polymers as is well known in the art. In one embodiment, the laminate material comprises a layer of polypropylene and a layer of polyvinyl alcohol (PvOH). The capsule materials may comprise at least a transparent region to provide visibility of the contents of the capsule.

[0036] Most preferably the sheet material of the hollow body of the sachet embodiment is a laminate comprising a layer of polypropylene and a layer of polyvinyl alcohol.

[0037] The dimensions of the sachet capsules of the sachet embodiment may be similar to those used in the existing systems described above so that the capsules of the invention can be used in existing beverage preparation equipment without modification of the equipment, particularly FLAVIA-type machines. Preferably, the sachet has a front and back size of about 10 cm by about 7 cm, or about 10 cm by about 5 cm. Preferably, the top face of the inlet nozzle of the sachet has the shape of an octahedron with two opposing sides of about 10 mm, two opposing sides of about 3 mm, two opposing sides of about 6 mm, and two opposing sides of about 3 mm.

[0038] In another embodiment, the hollow body is in the form of a pod comprising at least one sheet of plastic and/or metal foil material which is semi-rigid, e.g. thermoformed or injection moulded. The sheet material may be a laminate comprising at least one of the following layers: a thermoplastic sealant layer for bonding the hollow body to other members of the capsule; a substantially gas-impermeable barrier layer, which suitably is a metal film such as aluminium film; adhesion layers to improve

adhesion between other layers of the laminate; structural layers, for example to provide puncture resistance; and/or a printing substrate layer. The structural layers could be made of polyolefins, polystyrene, polyester, nylons, or other polymers as is well known in the art. The capsule materials may comprise at least a transparent region to provide visibility of the contents of the capsule.

[0039] Preferably, the pod embodiment may comprise a first sheet that has been formed, e.g. by thermoforming, into a cup or bowl shape with a flanged rim, and a second sheet that is bonded across the flanged rim to form the pod. For example, the first sheet may be a relatively stiff thermoplastic sheet that has been thermoformed into a cup or bowl shape with a flanged rim, and the second sheet is a flat sheet, which may be of flexible film material, that is bonded across the flanged rim. In these embodiments, the pod may have a frustoconical shape, suitably with a pierceable top and base. The bottom of the capsule is pierceable or otherwise provided with means for insertion of an outlet tube, for example a hole with a removable cover or a hinged cover, or a septum, or a split septum, or a nozzle with a frangible freshness barrier for example as described in WO-A-0219875.

[0040] The variable porosity filter material of the pod embodiment may suitably be secured to the inside surface of the pod by an adhesive or by welding to an annulus provided on the inside surface of pod, or in other embodiments it may be held in place by retaining flanges on the inside of the pod, or it may even be retained by a liquid-permeable sheet extending over the filter material and bonded to an internal surface of the pod around the periphery of the filter layer. The area of the filter material is suitably from about 1 cm² to about 20 cm², for example from about 2 cm² to about 10 cm².

[0041] It is particularly beneficial in the pod embodiment of the invention for the filter material to be less porous closer to the side wall of the hollow body and more porous closer the centre of the filter material.

[0042] Alternatively or additionally, the variable porosity filter material may be less porous closer to the top or inlet of the pod and more porous closer to the bottom or outlet of the pod.

[0043] In the pod embodiment, the filter material may be flexible or it may be rigid.

[0044] The dimensions of the capsules of the pod embodiment may be similar to those used in the existing systems described above so that the capsules of the invention can be used in existing beverage preparation equipment without modification of the equipment. Preferably, the internal volume of the pod is from about 1 cm³ to about 100 cm³, for example from about 5 cm³ to about 50 cm³.

[0045] Suitably, the side walls of the base component of the pod and the lid of the pod of the pod embodiment are provided with complementary engagement elements to secure the lid to the base. Suitable elements are complementary projections or recesses, for example threads, bayonet fittings or snap-fitting elements. Suitably, the en-

gagement elements are releasable to permit disassembly of the pod into the lid and the base after beverage preparation. Therefore, suitably the pod is not formed by adhesive or melt bonding of the lid to the base.

5 **[0046]** The bottom and side walls of the pod embodiment may be formed from air- and moisture-impermeable material as hereinbefore described so as to maintain freshness of the beverage ingredient before use. In these
10 embodiments, the pod comprises an outlet that is opened before or during beverage preparation to release the beverage formed inside the pod. For example, the outlet may be an opening in the pod that is sealed by a cover sheet adhered to the pod by a pressure-sensitive adhesive. The cover sheet is removed and discarded immediately
15 prior to assembling the capsule. Alternatively, the sheet material of the pod may be provided with a line of weakness, e.g. a die-cut line of weakness, defining an opening, for example a C-shaped or U-shaped line of weakness. The user presses down on the sheet material to open
20 the pod along the line of weakness immediately before use. In yet other embodiments the opening is sealed by a flap that is adhered around the opening by an adhesive that is releasable by heat or pressure inside the pod arising from injection of hot water into the pod.

25 **[0047]** In an alternative form of the pod embodiment at least a region of the bottom and/or the side walls of the pod may be made of a liquid-permeable material, which functions as the filter material for the beverage produced by injecting water through the lid of the pod. In
30 some embodiments, the bottom wall of the pod may be inclined relative to the side walls and functions as the inclined filter material previously described. Preferably, the bottom wall of the pod, acting as the filter material, may be less porous closer to the side wall of the hollow
35 body and more porous closer the centre of the bottom wall, and/or may be less porous closer to the top or inlet of the pod and more porous further from the top or inlet of the pod. The pod is suitably packaged in an air- and moisture-impermeable package to maintain freshness of the beverage ingredient before use.

40 **[0048]** In a further aspect, the present invention provides a method of preparing a beverage, comprising the step of passing an aqueous liquid through a beverage preparation capsule according to the present invention.
45 The aqueous liquid is preferably water, for example at a temperature of 85°C to 99°C. The method may be performed in the beverage preparation apparatus already known for use with existing capsule formats, for example as described in the patent references listed above, without modification of the apparatus. The water may suitably be injected at a pressure of 0.5 to 1.5 bar gauge for filter-type coffee, and at higher pressures such as 5-20 bar gauge for espresso-type coffee, depending on the system.

55 **[0049]** In a method of preparing a beverage using the sachet capsule embodiment of the present invention, a water injection tube may be inserted into the hollow body through a nozzle located in the top end or top end region

side wall of the hollow body, and then liquid may be injecting onto a beverage preparation ingredient inside the hollow body to prepare the beverage or beverage component. The bottom end or bottom end region side wall of the hollow body may be provided with a heat- and/or pressure-sensitive seal which ruptures open upon introduction of liquid into the hollow body, to allow beverage to escape from the hollow body through the outlet tube.

[0050] In a method of preparing a beverage using the pod capsule embodiment of the present invention, the top end or top end region side wall of the hollow body may be pierced with an inlet tube, such that the opening of the inlet tube resides above the sheet of filter material, and liquid may then be injected onto a beverage preparation ingredient inside the hollow body to prepare the beverage or beverage component. The bottom end or bottom end region side wall of the hollow body may also be pierced with an outlet tube, either before or after injecting liquid into the hollow body, such that the opening of the outlet tube resides below the sheet of filter material, and then the beverage can be allowed to escape from the hollow body through the outlet tube.

[0051] The term "variable porosity" herein is used in the sense that the porosity of a material, such as the filter material, changes across the extent of the material. Preferably, the porosity is greater at one end of the material than at an opposite end. However, the porosity could also change in other directions or orientations, not limited to a strictly linear or longitudinal progression. For example, the porosity could change as a function of radius from the centre of the filter material, such as in a series of concentric rings of differing porosities.

[0052] The term "filter material" herein is used in the sense of a material which can partially or substantially prevent or retard passage of at least a portion of beverage preparation ingredient, but allow passage of beverage liquid. In some embodiments, the beverage preparation ingredient may be an infusible-type ingredient, such as ground coffee or leaf tea, in which case, the filter material should substantially prevent passage of residual waste solid ingredient, such as coffee grounds and tea leaves, out of the capsule. However, in other embodiments, the beverage preparation ingredient may be a dispersible- or dissolvable-type ingredient, such as soup, in which case the filter material should allow passage of dispersed or dissolved ingredient with the beverage liquid, but should prevent passage of undispersed or undissolved ingredient, out of the capsule.

[0053] The term "hollow body" is used herein in its usual sense of a three-dimensional shape including an enclosure for retaining the beverage brewing ingredient. It will be appreciated that the hollow body may be of any suitable shape in plan view, including circular, square, other regular polygons, or trapezoidal. The hollow body defines an ingredient chamber in which the beverage preparation ingredient may be stored, and in which the beverage may be prepared by infusion or dissolution of the beverage preparation ingredient. Preferably, the in-

redient chamber is suitably substantially filled by the ingredient.

[0054] The terms "top end" and "bottom end", and related expressions such as "above", "below", "higher" and "lower" are relative expressions intended to clarify the relative positions of elements of the capsule, with reference to the accompanying drawings. While the "top end" of the capsule may indeed be the uppermost in use, it will readily be appreciated by the skilled person that this may not necessarily be the case, depending on the orientation of the beverage preparation machine. In any event, the "top" or "upper" regions of the capsule are those that are upstream, and "bottom" or "lower" elements are downstream with respect to the flow of liquid during beverage preparation.

[0055] Similarly, the terms "front" and "back" are relative expressions intended to clarify the relative positions of elements of the capsule, with reference to the accompanying drawings. In particular, a "front" portion of the capsule will typically be located in an opposing arrangement to a "back" portion. However, it will be readily appreciated that the "front" portion of the capsule need not necessarily face the user, depending upon orientation of the capsule, in or outside of a beverage preparation machine.

[0056] The term "outlet channel" refers to a channel extending from the beverage ingredient chamber, through which the beverage escapes from the chamber during beverage preparation. Preferably, the outlet channel is substantially free of beverage ingredient. Preferably, the outlet channel has a length in the direction of flow of the beverage, and a cross-section perpendicular to that flow.

[0057] The term "frangible freshness barrier" herein is used in the sense of a seal or cap over an inlet, outlet or other opening in the capsule, such that the quality of a beverage preparation ingredient inside the capsule does not degrade over time, for example due to atmospheric moisture or bacteria. Moreover, the freshness barrier is frangible in the sense that the seal or cap can be broken or opened to allow the capsule to be used to prepare a beverage.

[0058] The term "sachet" herein is used in the sense of substantially flexible bag or pouch, in which a beverage preparation ingredient may be stored.

[0059] The term "pod" herein is used in the sense of a substantially rigid container, preferably formed from a substantially rigid bowl or cup with a substantially rigid or substantially flexible lid or top thereover, in which a beverage preparation ingredient may be stored.

[0060] The term "inclined" herein is used in the normal sense of sloping between a higher position to a lower position.

[0061] An embodiment of the present invention will now be described further, by way of example, with reference to the accompanying drawings, in which:

Figure 1 shows a perspective view of a beverage

preparation capsule according to the prior art; Figures 2a and 2b show cross-sectional views of the beverage preparation capsule of Figure 1 before and in use respectively;

Figure 3 shows a perspective view of a beverage preparation capsule according to a sachet embodiment of the present invention;

Figures 4a and 4b show a cross-sectional view of the beverage preparation capsule of Figure 3 before and in use respectively;

Figure 5 shows a perspective view of a beverage preparation capsule according to a pod embodiment of the present invention;

Figures 6a and 6b show a cross-sectional view of the beverage preparation capsule of Figure 5 before and in use respectively;

Figure 7 shows a filter material of the present invention having variable porosity regions in use, arranged in an inclined filter material embodiment,

Figure 8 shows a filter of the present invention having variable porosity regions,

Figure 9 shows a cross-sectional view of a beverage preparation capsule according to a sachet embodiment of the present invention, formed from a single sheet of liquid- and air- impermeable material,

Figure 10 shows a cross-sectional view of a beverage preparation capsule according to a sachet embodiment of the present invention, formed from two sheets of liquid- and air- impermeable material,

Figure 11 shows a cross-sectional view of a beverage preparation capsule according to a pod embodiment not encompassed by the present invention with a round or flat bottom U-shaped filter material.

[0062] Referring to Figure 3, the sachet embodiment of the beverage preparation capsule of the present invention 200 comprises front and back sheets 210, 212 of a liquid- and air-impermeable sheet material permanently bonded together around their top and side edges as described in more detail below. The front and back sheets are also bonded together along a bottom edge 220 of the capsule, but this bond is releasable under the effect of heat or pressure inside the capsule. For example, the bonding of the bottom edge 220 may be by means of a pressure-sensitive adhesive. The capsule 200 further comprises a nozzle 240 having tubular bore 242. The nozzle is inserted into the top edge of the capsule and bonded in airtight fashion to the front and back sheets, the nozzle being flanged to assist in locating the capsule 200 correctly with a beverage preparation machine. The nozzle bore is initially sealed by a suitable airtight freshness barrier. Within the hollow cavity 260 of the capsule 200 is an inclined sheet of filter material 230 bonded to the inside walls of the front and back sheets 210, 212. The filter material 230 is a web material or a nonwoven material. The sheet of filter material 230 is inclined with respect to the front and back sheets 210, 212 of the sachet, in that it extends from a higher position

on the front sheet 210 of the sachet that is closer to the inlet nozzle 240 to a lower position on the back sheet 212 of the sachet that is closer to the outlet region 220. The filter material 230 is bonded to the inside walls of the front and back sheets 210, 212 around the whole periphery of the filter material, thereby dividing the hollow cavity 260 of the sachet into an inlet chamber 261 for receiving liquid and an outlet chamber 262 for dispensing liquid. The sheet of filter material supports a beverage preparation ingredient 250, such as ground coffee or leaf tea.

[0063] In use, the capsule 200 is introduced into a FLAVIA dispensing machine, which comprises a clamp to grip the nozzle 240 under the flange, and a hollow injector tube with a mechanism to insert the hollow injector tube into the nozzle bore 242, thereby piercing the freshness barrier. The dispensing machine further comprises a source of hot water and a pump to inject the hot water through the injector tube into the capsule. Upon introduction of the hot water through the injector tube and the nozzle bore 242 into the inlet chamber 261 of the capsule 200, the beverage preparation ingredient 250 contained in the capsule 200 is mixed with the hot water and a beverage is brewed. The bottom seam 220 of the capsule 200 opens under the effect of heat and liquid pressure inside the capsule, and the beverage passes through the filter sheet 230 into the outlet chamber 262 of the capsule 200 and through the open bottom of the capsule 200 and is collected in a receptacle located at a receptacle station situated directly below the capsule 200.

[0064] It can be seen that the bonding between the front and back sheets of the capsule 200 comprises a pair of side seams 216 extending downwardly from a top seam 214 and tapering inwardly at the bottom seam 220. The side seams 216 each include a sealed land 218 extending inwardly to form a 'waist' to the capsule. When the capsule is in use, the additional bonding area of the lands helps to maintain the capsule in a tubular configuration. In particular, the lands 218 reduce the tendency of bottom edge of the capsule to curl upwards as it opens, thereby providing improved control over the flow of beverage from the bottom of the capsule. The lands 218 thus provide a more consistent and regular opening of the capsule. Further details of this feature may be found in EP-A-0247841.

[0065] Referring to Figure 4a, the sheet of filter material 230 is inclined with respect to the front and back sheets 210, 212 of the sachet, extending from a higher position on the front sheet 210 of the sachet that is closer to the inlet nozzle 240 to a lower position on the back sheet 212 of the sachet that is closer to the outlet region 220. The filter material supports the infusible beverage preparation ingredient 250.

[0066] Referring to Figure 4b, upon introduction of liquid through the nozzle 240 into the inlet chamber 261 of the capsule 200, the liquid contacts the beverage preparation ingredient 250 and infuses therewith to create the beverage. The liquid beverage then passes through the sheet of filter material 230 into the outlet chamber 262,

leaving behind the waste solid beverage preparation ingredient. The passage of liquid ruptures of the pressure-sensitive seal of the bottom seam 220 to dispense the beverage brewed in the capsule 200. The inclined sheet of the filter material 230 provides a large surface area that is greater than the transverse cross sectional area of the hollow cavity of the sachet. In this way, the liquid and infusible beverage preparation ingredient has a greater surface area through which liquid may pass, quickly and easily, without the need for excess pressure which could rupture the sachet 200.

[0067] Referring to Figures 5 and 6a, the pod embodiment of the beverage preparation capsule of the present invention 300 comprises a cup element 310 having a substantially flat base 311, a flanged top 312, and frustoconical side walls 313 extending from the base 311 to the top 312. The cup element is formed for example by thermoforming from a suitable thermoplastic for example polystyrene. The thickness and material of the cup element are selected so that the cup element has sufficient rigidity to allow piercing of the base during beverage preparation, as described below, without collapse of the cup. The flanged top 312 of the cup is sealed with a flexible film lid 320 of a suitable laminate sheet material as hereinbefore described. The lid 320 is bonded to the lip of the flanged top 312 by melt binding or adhesive bonding in a conventional fashion.

[0068] A sheet of filter material 330 is provided inside the capsule 300 in an inclined orientation. The filter material 330 is a sheet of nonwoven textile material or a web material. The filter material 330 is secured to the inside surfaces of the side walls 313 of the cup 310 by an adhesive or by welding to an annulus provided on the inside surfaces of the side walls of the cup. The beverage preparation ingredient 350, which in this example is ground coffee, is deposited on top of the filter material 330 inside the capsule 300.

[0069] In use, the capsule 300 is held inside a clamp of a beverage-making apparatus as shown in Figure 6b. The clamp has a lower part 361 with a recess for mating engagement with the cup element 310 of the capsule, and an upper clamp part 362 that is moveable to abut the lid 320 of the capsule. In this example, the capsule is gripped by the clamp and only partially enclosed by the clamp during beverage preparation. However, in alternative embodiments, the capsule may be completely enclosed by the clamp, which permits the use of elevated pressures during beverage preparation without bursting the capsule. Alternatively, the flange 312 of the capsule may simply be supported by an annular collar of the beverage-making apparatus.

[0070] The beverage-making apparatus comprises a source of water (not shown), suitably a source of hot water, for supplying water to an injection tube 371 that pierces the lid of the capsule to inject water into the capsule for preparation of the beverage. The beverage preparation apparatus further comprises an outlet tube 372 that pierces the base of the capsule and projects a short dis-

tance into the capsule, whereby the open end of the outlet tube is located below the sheet of filter material 330. The inlet and outlet tubes may be fixed in spatial relationship to the respective clamp parts, in which case piercing of the capsule takes place when the clamp is closed around the capsule.

[0071] Alternatively, the inlet and outlet tubes may be associated with mechanisms to provide reciprocating motion of the respective tubes into the capsule after the capsule has been clamped and out of the capsule after beverage preparation is complete. It will be appreciated that more than one inlet and/or outlet tube may be provided if appropriate.

[0072] It can be seen that the capsule 300 according to this embodiment of the invention is extremely simple and inexpensive to manufacture, and can be adapted to capsules for use in any existing beverage preparation equipment that uses beverage capsules that are pierced by an outlet tube. As in the previous embodiments, the inclined sheet of the filter material 330 provides a large surface area that is greater than the transverse cross sectional area of the hollow cavity of the pod. In this way, the liquid and infusible beverage preparation ingredient has a greater surface area through which liquid may pass, quickly and easily, without the need for excess pressure.

[0073] Referring to Figure 7, a filter material arrangement is shown which is representative of that used in the sachet embodiment of the present invention, in which the filter material 430 has variable porosity along its length. However, this type of filter material may be used in other arrangements, including any of the arrangements shown in Figures. 1 to 6. In Figure 7, the filter material 430 is thicker 431 and thus less porous closer to the top or inlet 440 of the sachet and thinner 432 and thus more porous closer to the bottom or outlet 420 of the sachet. In this way, the pressure drop (Δ -P) is similar or the same across the whole filter material 430 and a consistent flow of liquid 470 is encouraged through the whole beverage material 450. This helps to avoid liquid channelling through a passage of least resistance and leaving some beverage material uncontacted with liquid.

[0074] Figure 8 shows an alternative example of a sheet of filter material with variable porosity along its longitudinal length, in which pores 531 progressively increase in size from one lateral end 532 to another lateral end 533. A further alternative embodiment could use different pore density, or different materials of the filter to provide variable porosity, for example materials with variable hydrophobicity.

[0075] Figure 9 shows an embodiment of a sachet 600 in which the front sheet 610, filter material 630 and back sheet 612 are formed from a single sheet of a liquid- and air-impermeable material folded into an "M" shape (alternatively the sheet could be folded into a "N" shape, simply being the mirror image of the sachet of Figure 9). Since the sheet material is liquid- and air-impermeable material, a filter region 630 of the sheet is perforated such

that the sheet becomes at least partially porous in the filter region 630. The sheet may be laser perforated and may be combined with an additional laminated layer of non-woven filter material. The front and back sheets 610, 612 are permanently bonded together around their top and side edges, with the filter portion of the sheet 630 being left free to extend across the interior of the sachet, thereby dividing the hollow cavity of the sachet into an inlet chamber 661 for receiving liquid and an outlet chamber 662 for dispensing liquid. The front and back sheets 610, 612 are also bonded together along a bottom edge 620 of the capsule, but this bond is releasable under the effect of heat or pressure inside the capsule. For example, the bonding of the bottom edge 620 may be by means of a pressure-sensitive adhesive. The capsule 600 further comprises a nozzle 640 having tubular bore. The nozzle is inserted into the top edge of the capsule and bonded in airtight fashion, the nozzle being flanged to assist in locating the capsule 600 correctly with a beverage preparation machine. The nozzle bore is initially sealed by a suitable airtight freshness barrier. The sheet of filter material 630 supports a beverage preparation ingredient 650, such as ground coffee or leaf tea. Preferably, the perforations in the filter material 630 are more numerous in the lower regions of the filter material 630, such that the porosity of the filter material 630 is greater closer to the outlet 620 of the sachet and less porous closer to the inlet nozzle 640.

[0076] Figure 10 shows another embodiment of a sachet 700 in which the front sheet 710 and filter material 730 are formed from a first sheet of a liquid- and air-impermeable material, folded into a "V" shape (alternatively the sheet could be folded into a "Λ" shape). Since the sheet material is liquid- and air-impermeable, a filter region 730 of the sheet is perforated such that the sheet becomes at least partially porous in the filter region 730. The sheet may be laser perforated and may be combined with a laminated layer of non-woven filter material. A second sheet of liquid- and air-impermeable material is connected to the filter material portion 730 of the first sheet to form the back sheet 712 of the sachet. The front and back sheets 710, 712 are permanently bonded together around their top and side edges, with the filter portion of the sheet 730 being left free to extend across the interior of the sachet, thereby dividing the hollow cavity of the sachet into an inlet chamber 761 for receiving liquid and an outlet chamber 762 for dispensing liquid. The front and back sheets 710, 712 are also bonded together along a bottom edge 720 of the capsule, but this bond is releasable under the effect of heat or pressure inside the capsule. For example, the bonding of the bottom edge 720 may be by means of a pressure-sensitive adhesive. The capsule 700 further comprises a nozzle 740 having tubular bore. The nozzle is inserted into the top edge of the capsule and bonded in airtight fashion, the nozzle being flanged to assist in locating the capsule 700 correctly with a beverage preparation machine. The nozzle bore is initially sealed by a suitable airtight freshness bar-

rier. The sheet of filter material 730 supports a beverage preparation ingredient 750, such as ground coffee or leaf tea. Preferably, the perforations in the filter material 730 are more numerous in the lower regions of the filter material 730, such that the porosity of the filter material 730 is greater closer to the outlet 720 of the sachet and less porous closer to the inlet nozzle 740.

[0077] Figure 11 shows an embodiment not encompassed by the present invention of a pod 800 comprising a cup element 810 having a substantially flat base 811, a flanged top 812, and frustoconical side walls 813 extending from the base 811 to the top 812. The cup element is formed for example by thermoforming from a suitable thermoplastic for example polystyrene. The thickness and material of the cup element are selected so that the cup element has sufficient rigidity to allow piercing of the base during beverage preparation, as described below, without collapse of the cup. The flanged top 812 of the cup is sealed with a flexible film lid 820 of a suitable laminate sheet material as hereinbefore described. The lid 820 is bonded to the lip of the flanged top 812 by melt binding or adhesive bonding in a conventional fashion. A sheet of filter material 830 is provided inside the capsule 300 as a single sheet of non-folded material in a round bottomed or flat-bottomed U shape. The filter material 830 is a sheet of nonwoven textile material or a web material. The filter material 830 is secured to the inside surfaces of the side walls 813 of the cup 810 by an adhesive or by welding to an annulus provided on the inside surfaces of the side walls of the cup. The beverage preparation ingredient 850, which in this example is ground coffee, is deposited on top of the filter material 830 inside the capsule 800. The porosity of the filter material 830 is greater towards the central bottom region 831 of the U shaped filter material 830 and less porous towards the edges 832 of the filter material closer to the side walls 813 of the cup.

[0078] It should be understood that the above embodiments have been described by way of example only. Many other embodiments falling within the scope of the accompanying claims will be apparent to the skilled reader. It will further be understood that any feature disclosed in relation to any one embodiment may alternatively or additionally be present in any of the other embodiments.

Claims

1. A beverage preparation capsule (200) comprising a hollow body suitable for containing a beverage preparation ingredient (250), the hollow body having a top end for receiving liquid into the hollow body, a bottom end for dispensing the beverage from the hollow body, and at least one side wall between the top and bottom ends, the bottom end being in fluid communication with the top end; and **characterized by**

the hollow body containing a filter material (230)

- having a variable porosity along at least one dimension of the filter material's (230) surface area, wherein the filter material (230) is less porous closer to the top or inlet of the hollow body and more porous closer to the bottom or outlet of the hollow body, or wherein the filter material (230) is less porous closer to the side wall of the hollow body and more porous closer to the centre of the filter material (230), or a combination of both,
wherein the sheet of filter material (230) extends across the inside of the hollow body at an incline relative to the side wall.
2. The beverage preparation capsule (200) of claim 1, in which the variable porosity of the filter material (230) is provided by variable thickness, variable pore size, variable pore density or variable composition of the filter material (230).
 3. The beverage preparation capsule (200) of claim 1 or 2, wherein the sheet of filter material (230) directly extends from a first position on a side wall to a second position on a side wall, wherein said first position is relatively closer to the top end of the hollow body and the second position is relatively closer to the bottom end of the hollow body, optionally where the porosity of the filter material (230) increases from the first position relatively closer to the top end of the hollow body towards the second position relatively closer to the bottom end of the hollow body, preferably wherein the porosity of the filter material (230) increases by a gradation of porosities.
 4. The beverage preparation capsule (200) of any of claims 1 to 3, wherein the sheet of filter material (230) is a single sheet of non-folded material.
 5. The beverage preparation capsule (200) of any of claims 1 to 4, wherein the sheet of filter material (230) divides the hollow body into an inlet chamber (261) for receiving liquid and an outlet chamber (262) from which the beverage is dispensed.
 6. The beverage preparation capsule (200) of any preceding claim, wherein the surface area of the filter material (230) is greater than the transverse cross-sectional area of the cavity of the hollow body.
 7. The beverage preparation capsule (200) of any preceding claim, comprising a beverage preparation ingredient (250) supported on the filter material (230) between the filter material (230) and the top end of the hollow body, the beverage preparation ingredient (250) preferably being ground coffee or leaf tea, optionally wherein the beverage preparation ingredient (250) is hermetically sealed in the capsule (200) before use.
 8. The beverage preparation capsule (200) of any preceding claim, wherein the filter material (230) is a web material or a nonwoven fabric material.
 9. The beverage preparation capsule (200) of any preceding claim, which is a single-serve capsule (200), preferably for the preparation of from about 25 ml to about 500 ml of beverage, and/or preferably containing from about 2 g to about 25 g of ground coffee or from about 1 g to about 9 g of leaf tea, or from about 2 g to about 30 g of water dispersible ingredients (250).
 10. The beverage preparation capsule (200) of any preceding claim, wherein the hollow body is in the form of a sachet comprising front and back sheets (210, 212) of flexible film material arranged in face-to-face relationship and sealed along their edges, wherein the filter material (230) extends from the front sheet (210) of the hollow body to the back sheet (212) of the hollow body, optionally wherein the front and back sheets (210, 212) of the hollow body are air- and water-impermeable laminate sheets.
 11. The beverage preparation capsule (200) of claim 10, wherein front and back sheets (210, 212) of the hollow body are permanently bonded together along edge seams (216) and a top seam (214) with an outlet region being provided in a bottom seam (220) of the hollow body, and wherein a liquid injection nozzle (240) is inserted into the top seam (214) or an edge seam (216) of the hollow body, optionally wherein the filter material (230) is an inclined sheet extending from a first position on one sheet of the hollow body, wherein said first position is relatively closer to the inlet nozzle (240), to a second position on the opposite sheet of the hollow body, wherein said second position is relatively closer to the outlet region, optionally wherein the outlet region is sealed with a heat- and/or pressure-releasable bond.
 12. The beverage preparation capsule (200) of any of claims 10 to 11, wherein a region of the flexible film material of the front (210) and/or back sheet (212) is at least partially porous, such that the porous region of the flexible film material acts as the sheet of filter material (230).
 13. The beverage preparation capsule (200) of any of claims 1 to 9, wherein the hollow body is in the form of a pod comprising at least one sheet of semi-rigid material, optionally wherein the sheet of semi-rigid material is a laminate comprising at least one of the following layers: a thermoplastic sealant layer for bonding the hollow body to other members of the capsule (200); a substantially gas-impermeable barrier layer; adhesion layers to promote adhesion between the layers of the laminate; structural layers,

optionally comprising a first sheet of semi-rigid material formed into a cup or bowl shape (310) with a flanged rim (312), and a second sheet of flexible or semi-rigid material (320) that is bonded across the flanged rim (312) to form the hollow body.

14. The beverage preparation capsule (200) of claim 13, wherein at least one wall of the hollow body is pierceable by an inlet or outlet tube (371, 372) of a beverage preparation apparatus, preferably wherein the top end and bottom end of the hollow body are both pierceable.

Patentansprüche

1. Kapsel (200) für die Getränkezubereitung, umfassend einen hohlen Körper, der dazu geeignet ist, eine Getränkezubereitungszutat (250) zu enthalten, wobei der hohle Körper ein oberes Ende zur Aufnahme von Flüssigkeit in den hohlen Körper, ein unteres Ende zur Abgabe des Getränks aus dem hohlen Körper, und mindestens eine Seitenwand zwischen dem oberen und dem unteren Ende aufweist, wobei das untere Ende mit dem oberen Ende in Fluidverbindung steht; und **dadurch gekennzeichnet, dass** der hohle Körper ein Filtermaterial (230) mit einer variablen Porosität entlang mindestens einer Dimension der Oberfläche des Filtermaterials (230) aufweist, wobei das Filtermaterial (230) näher bei der Oberseite oder beim Einlass des hohlen Körpers weniger porös ist und näher beim Boden oder Auslass des hohlen Körpers poröser ist, oder wobei das Filtermaterial (230) näher bei der Seitenwand des hohlen Körpers weniger porös und näher bei der Mitte des Filtermaterials (230) poröser ist, oder eine Kombination aus beiden,

wobei das Filtermaterial (230) ein Flächenstück aus Filtermaterial ist,
wobei sich das Flächenstück aus Filtermaterials (230) über die Innenseite des hohlen Körpers mit einer Neigung im Verhältnis zur Seitenwand erstreckt.

2. Kapsel (200) für die Getränkezubereitung nach Anspruch 1, wobei die variable Porosität des Filtermaterials (230) durch variable Dicke, variable Porengröße, variable Porendichte oder variable Zusammensetzung des Filtermaterials (230) bereitgestellt wird.

3. Kapsel (200) für die Getränkezubereitung nach Anspruch 1 oder 2,

wobei sich das Flächenstück aus Filtermaterial (230) direkt von einer ersten Position an einer Seitenwand zu einer zweiten Position an einer

Seitenwand erstreckt, wobei die erste Position relativ näher beim oberen Ende des hohlen Körpers liegt und die zweite Position relativ näher beim unteren Ende des hohlen Körpers liegt, wobei die Porosität des Filtermaterials (230) fakultativ von der ersten Position, die relativ näher beim oberen Ende des hohlen Körpers ist, zur zweiten Position, die relativ näher beim unteren Ende des hohlen Körpers ist, zunimmt, wobei die Porosität des Filtermaterials (230) vorzugsweise um eine Abstufung von Porositäten zunimmt.

4. Kapsel (200) für die Getränkezubereitung nach einem der Ansprüche 1 bis 3, wobei das Flächenstück aus Filtermaterial (230) ein einzelnes Flächenstück aus nicht gefaltetem Material ist.

5. Kapsel (200) für die Getränkezubereitung nach einem der Ansprüche 1 bis 4, wobei das Flächenstück aus Filtermaterial (230) den hohlen Körper in eine Einlasskammer (261) zur Aufnahme von Flüssigkeit und eine Auslasskammer (262), aus der das Getränk abgegeben wird, unterteilt.

6. Kapsel (200) für die Getränkezubereitung nach einem der vorhergehenden Ansprüche, wobei die Oberfläche des Filtermaterials (230) größer als die transversale Querschnittsfläche des Hohlraums des hohlen Körpers ist.

7. Kapsel (200) für die Getränkezubereitung nach einem der vorhergehenden Ansprüche, umfassend eine Getränkezubereitungszutat (250), die auf dem Filtermaterial (230) zwischen dem Filtermaterial (230) und dem oberen Ende des hohlen Körpers getragen wird, wobei die Getränkezubereitungszutat (250) vorzugsweise gemahlener Kaffee oder loser Tee ist, wobei die Getränkezubereitungszutat (250) vor der Benutzung fakultativ hermetisch in der Kapsel (200) eingeschlossen ist.

8. Kapsel (200) für die Getränkezubereitung nach einem der vorhergehenden Ansprüche, wobei das Filtermaterial (230) eine Materialbahn oder ein Vliesmaterial ist.

9. Kapsel (200) für die Getränkezubereitung nach einem der vorhergehenden Ansprüche, bei der es sich um eine Kapsel (200) für eine Portion handelt, vorzugsweise zur Herstellung von ungefähr 25 ml bis ungefähr 500 ml eines Getränks, und/oder die vorzugsweise ungefähr 2 g bis ungefähr 25 g gemahlener Kaffee oder ungefähr 1 g bis ungefähr 9 g Teeblätter oder ungefähr 2 g bis ungefähr 30 g in Wasser dispergierbare Zutaten (250) enthält.

10. Kapsel (200) für die Getränkezubereitung nach ei-

nem der vorhergehenden Ansprüche, wobei der hohle Körper die Form eines Beutels hat, der vordere und hintere Flächenstücke (210, 212) aus einem flexiblen Folienmaterial umfasst, die in einander zugewandter Beziehung angeordnet und entlang ihrer Ränder versiegelt sind, wobei sich das Filtermaterial (230) vom vorderen Flächenstück (210) des hohlen Körpers zum hinteren Flächenstück (212) des hohlen Körpers erstreckt, wobei die vorderen und hinteren Flächenstücke (210, 212) des hohlen Körpers fakultativ luft- und wasserundurchlässige Verbundflächenstücke sind.

11. Kapsel (200) für die Getränkezubereitung nach Anspruch 10, wobei die vorderen und hinteren Flächenstücke (210, 212) des hohlen Körpers entlang Randnähten (216) und einer oberen Naht (214) permanent miteinander verbunden sind und eine Auslassregion in einer unteren Naht (220) des hohlen Körpers vorgesehen ist, und wobei eine Flüssigkeitseinspritzdüse (240) in die obere Naht (214) oder eine Randnaht (216) des hohlen Körpers eingeführt wird, wobei das Filtermaterial (230) fakultativ ein geneigtes Flächenstück ist, das sich von einer ersten Position auf einem Flächenstück des hohlen Körpers, wobei die erste Position relativ näher bei der Einlassdüse (240) liegt, zu einer zweiten Position auf dem gegenüberliegenden Flächenstück des hohlen Körpers erstreckt, wobei die zweite Position relativ näher bei der Auslassregion liegt, wobei die Auslassregion fakultativ mit einer durch Hitze und/oder Druck lösbaren Verbindung versiegelt ist.
12. Kapsel (200) für die Getränkezubereitung nach einem der Ansprüche 10 bis 11, wobei eine Region des flexiblen Folienmaterials des vorderen (210) und/oder hinteren Flächenstücks (212) mindestens teilweise porös ist, so dass die poröse Region des flexiblen Folienmaterials als das Flächenstück aus Filtermaterial (230) wirkt.
13. Kapsel (200) für die Getränkezubereitung nach einem der Ansprüche 1 bis 9, wobei der hohle Körper in Form einer Portionskapsel vorliegt, die mindestens ein Flächenstück aus einem halbstarren Material umfasst, wobei das Flächenstück aus halbstarrem Material fakultativ ein Laminat ist, das mindestens eine der folgenden Schichten umfasst: eine thermoplastische Siegelschicht zur Verbindung des hohlen Körpers mit anderen Elementen der Kapsel (200); eine im Wesentlichen gasundurchlässige Barrierschicht; Adhäsionsschichten zur Förderung der Adhäsion zwischen den Schichten des Laminats; strukturelle Schichten, die fakultativ ein erstes Flächenstück aus einem halbstarren Material in Form einer Tasse oder einer Schale (310) mit einem geflanschten Rand (312) und ein zweites Flächenstück aus einem flexiblen oder halbstarren Material (320)

umfassen, das über dem geflanschten Rand (312) geklebt ist, um den hohlen Körper zu bilden.

14. Kapsel (200) für die Getränkezubereitung nach Anspruch 13, wobei mindestens eine Wand des hohlen Körpers von einem Einlass- oder Auslassrohr (371, 372) einer Getränkezubereitungsrichtung durchstechbar ist, wobei das obere Ende und das untere Ende des hohlen Körpers vorzugsweise beide durchstechbar sind.

Revendications

1. Capsule de préparation de boisson (200) comprenant un corps creux adapté pour contenir un ingrédient de préparation de boisson (250), le corps creux ayant une extrémité de dessus pour recevoir un liquide dans le corps creux, une extrémité de fond pour distribuer la boisson depuis le corps creux, et au moins une paroi de côté entre les extrémités de dessus et de fond, l'extrémité de fond étant en communication fluïdique avec l'extrémité de dessus ; et **caractérisée en ce que** le corps creux contient une matière de filtre (230) ayant une porosité variable le long d'au moins une dimension de la superficie de la matière de filtre (230), dans laquelle la matière de filtre (230) est moins poreuse plus près du dessus ou de l'entrée du corps creux et plus poreuse plus près du fond ou de la sortie du corps creux, ou dans laquelle la matière de filtre (230) est moins poreuse plus près de la paroi de côté du corps creux ou plus poreuse plus près du centre de la matière de filtre (230), ou une combinaison des deux,
- dans laquelle la matière de filtre (230) est une feuille de matière de filtre,
- dans laquelle la feuille de matière de filtre (230) s'étend à travers l'intérieur du corps creux au niveau d'une pente par rapport à la paroi de côté.
2. Capsule de préparation de boisson (200) selon la revendication 1, dans laquelle la porosité variable de la matière de filtre (230) est assurée par une épaisseur variable, une taille de pore variable, une densité de pore variable ou une composition variable de la matière de filtre (230).
3. Capsule de préparation de boisson (200) selon la revendication 1 ou 2, dans laquelle la feuille de matière de filtre (230) s'étend directement depuis une première position sur une paroi de côté jusqu'à une seconde position sur une paroi de côté, dans laquelle ladite première position est relativement plus près de l'extrémité de dessus du corps creux, et la seconde position est relativement plus près de l'extrémité de fond du corps creux, facultativement où la porosité de la matière de filtre (230) augmente depuis la

- première position relativement plus près de l'extrémité de dessus du corps creux vers la seconde position relativement plus près de l'extrémité de fond du corps creux, de préférence dans laquelle la porosité de la matière de filtre (230) augmente par une gradation de porosités.
4. Capsule de préparation de boisson (200) selon l'une quelconque des revendications 1 à 3, dans laquelle la feuille de matière de filtre (230) est une feuille unique de matière non pliée.
 5. Capsule de préparation de boisson (200) selon l'une quelconque des revendications 1 à 4, dans laquelle la feuille de matière de filtre (230) divise le corps creux en une chambre d'entrée (261) pour recevoir un liquide et une chambre de sortie (262) depuis laquelle la boisson est distribuée.
 6. Capsule de préparation de boisson (200) selon l'une quelconque des revendications précédentes, dans laquelle la superficie de la matière de filtre (230) est plus grande que l'aire en coupe transversale de la cavité du corps creux.
 7. Capsule de préparation de boisson (200) selon l'une quelconque des revendications précédentes comprenant un ingrédient de préparation de boisson (250) supporté sur la matière de filtre (230) entre la matière de filtre (230) et l'extrémité de dessus du corps creux, l'ingrédient de préparation de boisson (250) étant de préférence du café moulu ou du thé en feuilles, facultativement dans laquelle l'ingrédient de préparation de boisson (250) est scellé hermétiquement dans la capsule (200) avant utilisation.
 8. Capsule de préparation de boisson (200) selon l'une quelconque des revendications précédentes, dans laquelle la matière de filtre (230) est une matière de voile ou une matière d'étoffe non tissée.
 9. Capsule de préparation de boisson (200) selon l'une quelconque des revendications précédentes, qui est une capsule-portion (200), de préférence pour la préparation d'environ 25 mL à environ 500 mL de boisson, et/ou contenant de préférence d'environ 2 g à environ 25 g de café moulu ou d'environ 1 g à environ 9 g de thé en feuilles, ou d'environ 2 g à environ 30 g d'ingrédients hydrodispersibles (250).
 10. Capsule de préparation de boisson (200) selon l'une quelconque des revendications précédentes, dans laquelle le corps creux est sous forme d'un sachet comprenant des feuilles avant et arrière (210, 212) de pellicule de conditionnement souple disposées en relation de face à face et scellées suivant leurs bords, dans laquelle la matière de filtre (230) s'étend depuis la feuille avant (210) du corps creux jusqu'à la feuille arrière (212) du corps creux, facultativement dans laquelle les feuilles avant et arrière (210, 212) du corps creux sont des feuilles stratifiées imperméables à l'air et à l'eau.
 11. Capsule de préparation de boisson (200) selon la revendication 10, dans laquelle les feuilles avant et arrière (210, 212) du corps creux sont collées ensemble le long de joints de bord (216) et d'un joint de dessus (214) avec une zone de sortie prévue dans un joint de fond (220) du corps creux, et dans laquelle une buse d'injection de liquide (240) est insérée dans le joint de dessus (214) ou un joint de bord (216) du corps creux, facultativement dans laquelle la matière de filtre (230) est une feuille inclinée s'étendant depuis une première position sur une feuille du corps creux, dans laquelle ladite première position est relativement plus près de la buse d'entrée (240), jusqu'à une seconde position sur la feuille opposée du corps creux, dans laquelle ladite seconde position est relativement plus près de la zone de sortie, facultativement dans laquelle la zone de sortie est scellée avec un collage réversible à la chaleur et/ou par pression.
 12. Capsule de préparation de boisson (200) selon l'une quelconque des revendications 10 et 11, dans laquelle une zone de la pellicule de conditionnement souple de la feuille avant (210) et/ou arrière (212) est au moins partiellement poreuse, de sorte que la zone poreuse de la pellicule de conditionnement souple serve de feuille de matière de filtre (230).
 13. Capsule de préparation de boisson (200) selon l'une quelconque des revendications 1 à 9, dans laquelle le corps creux est sous forme d'une dosette comprenant au moins une feuille de matière semi-rigide, facultativement dans laquelle la feuille de matière semi-rigide est un stratifié comprenant au moins l'une des couches suivantes: une couche de produit de scellement thermoplastique pour coller le corps creux à d'autres organes de la capsule (200); une couche barrière sensiblement imperméable aux gaz; des couches d'adhérence pour favoriser l'adhérence entre les couches du stratifié; des couches structurales, comprenant facultativement une première feuille de matière semi-rigide formée en une forme de tasse ou de bol (310) avec un rebord à lèvres (312), et une seconde feuille de matière souple ou semi-rigide (320) qui est collée à travers le rebord à lèvres (312) pour former le corps creux.
 14. Capsule de préparation de boisson (200) selon la revendication 13, dans laquelle au moins une paroi du corps creux est perforable par un tube d'entrée ou de sortie (371, 372) d'un appareil de préparation de boisson, de préférence dans laquelle l'extrémité de dessus et l'extrémité de fond du corps creux sont

toutes deux perforables.

5

10

15

20

25

30

35

40

45

50

55

15

FIG. 1 (Prior art)

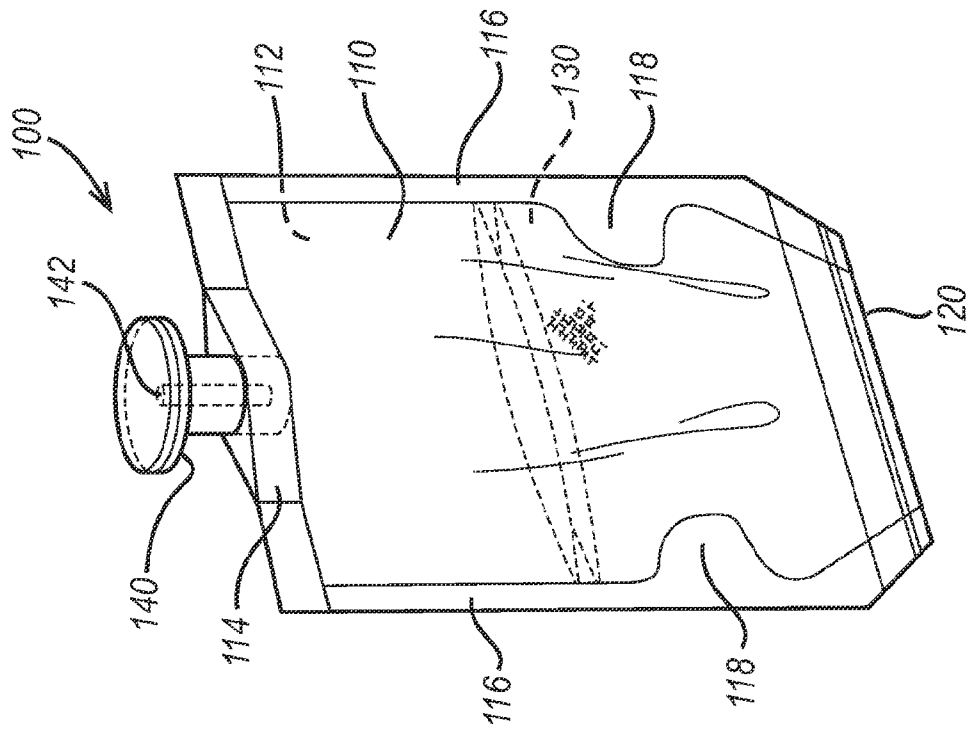

FIG. 2a (Prior art)

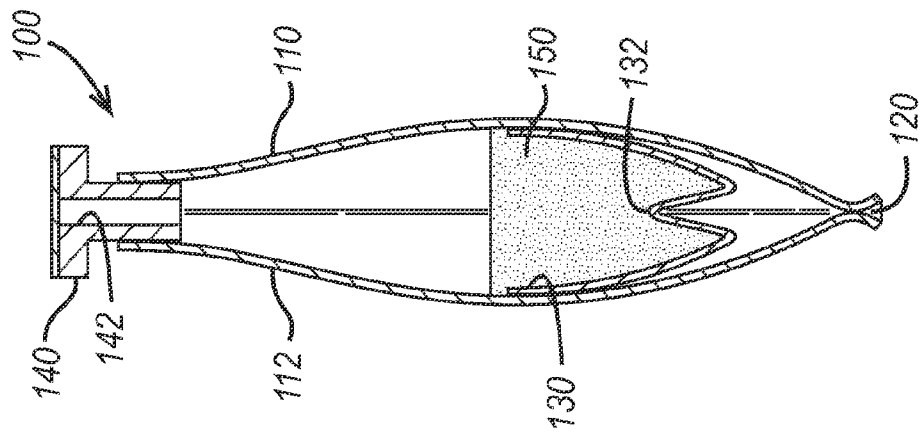
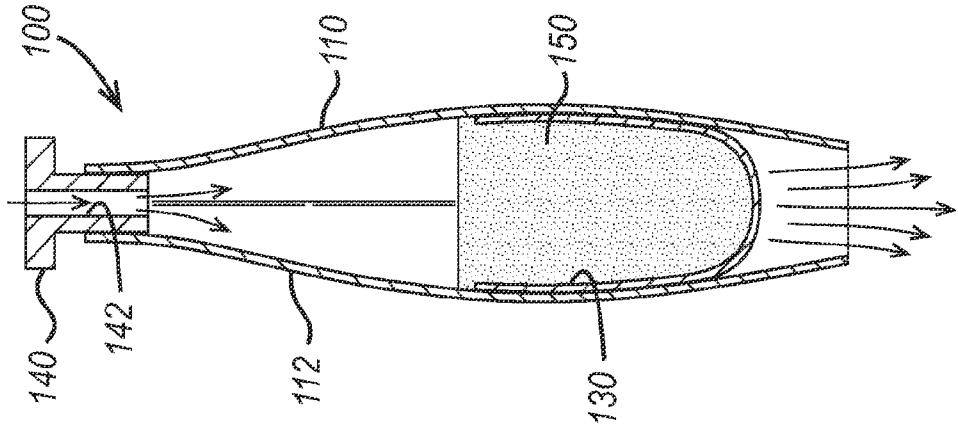

FIG. 2b (Prior art)



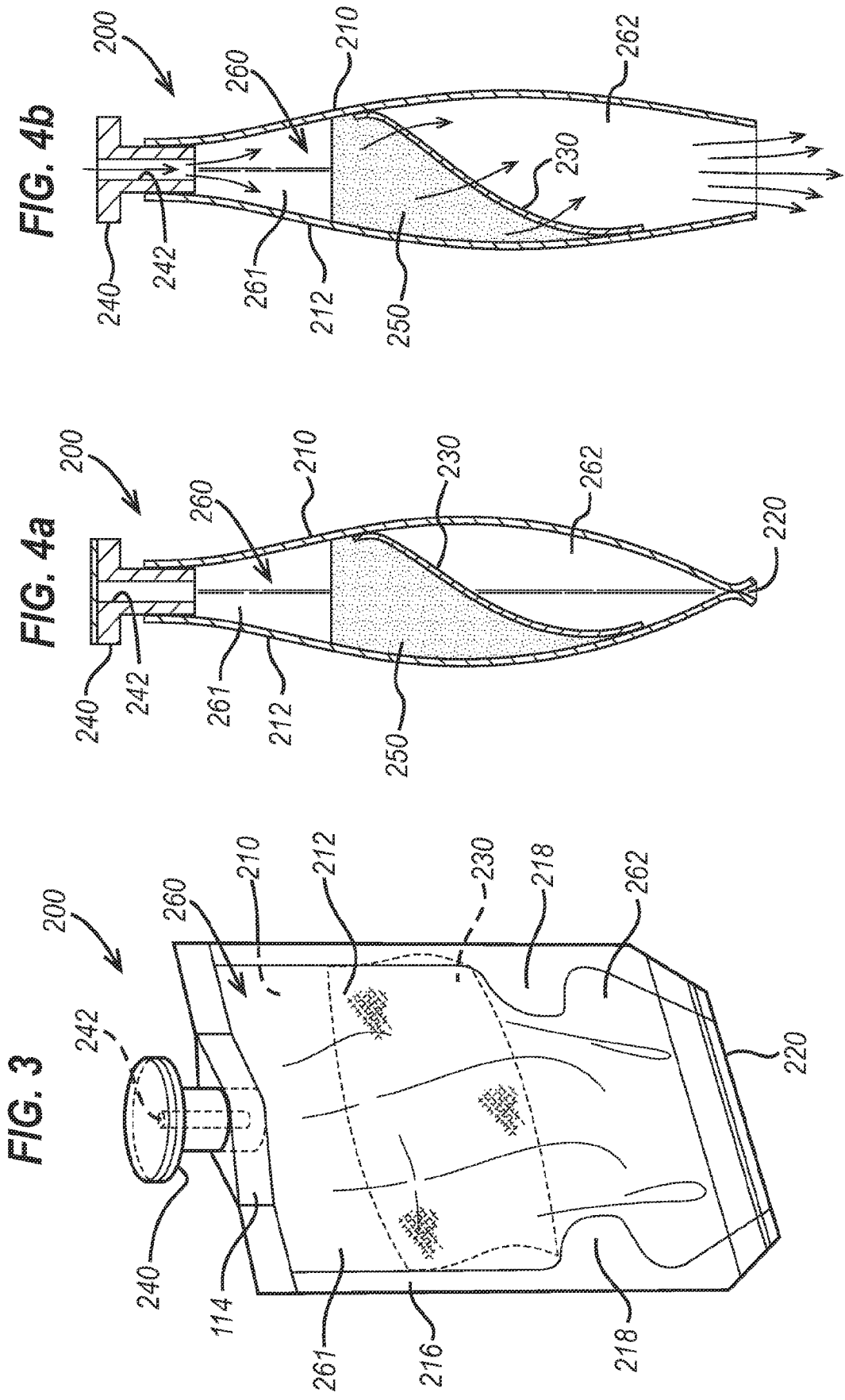

FIG. 5

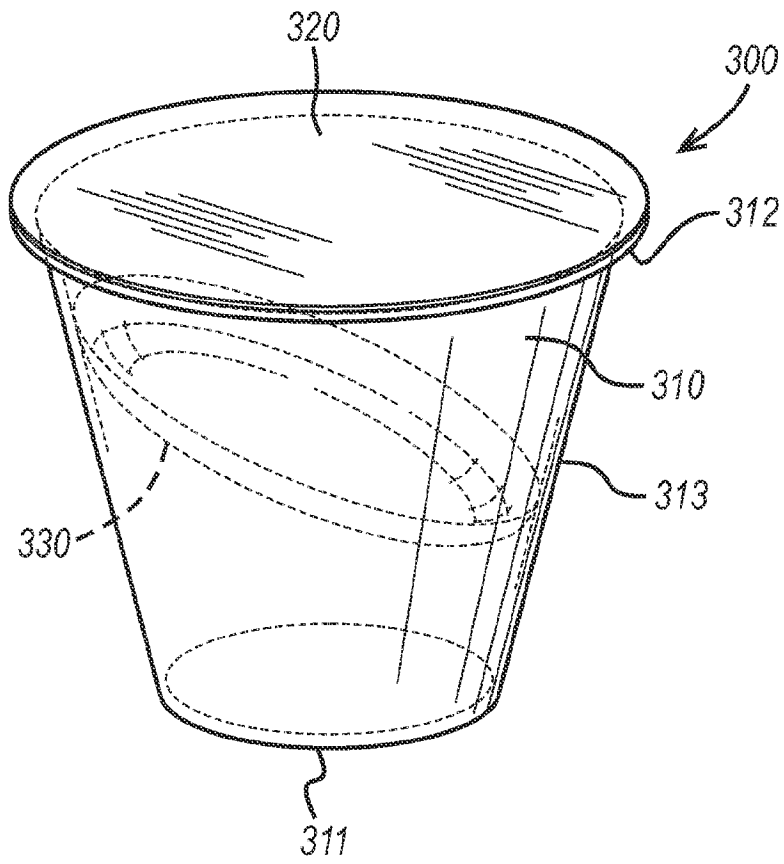

FIG. 6a

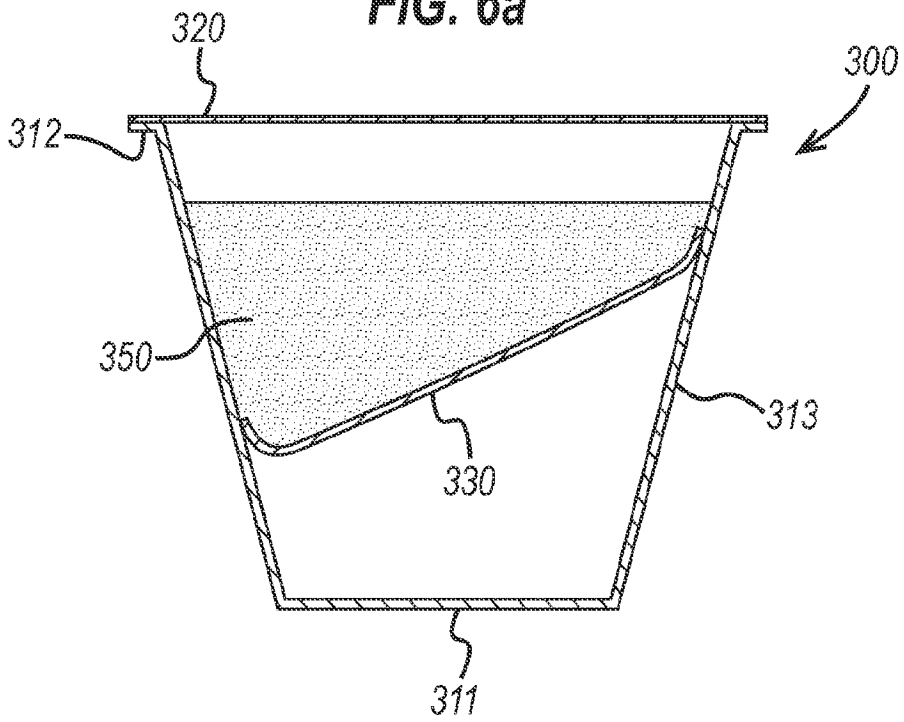

FIG. 6b

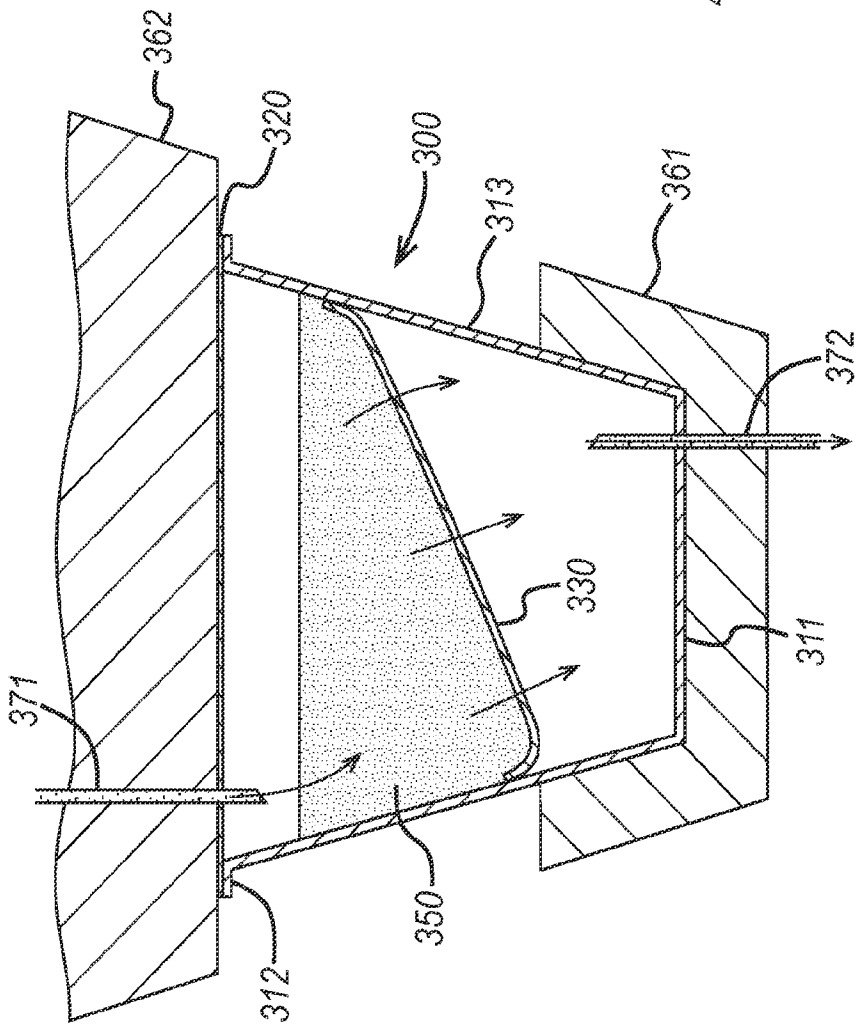

FIG. 7

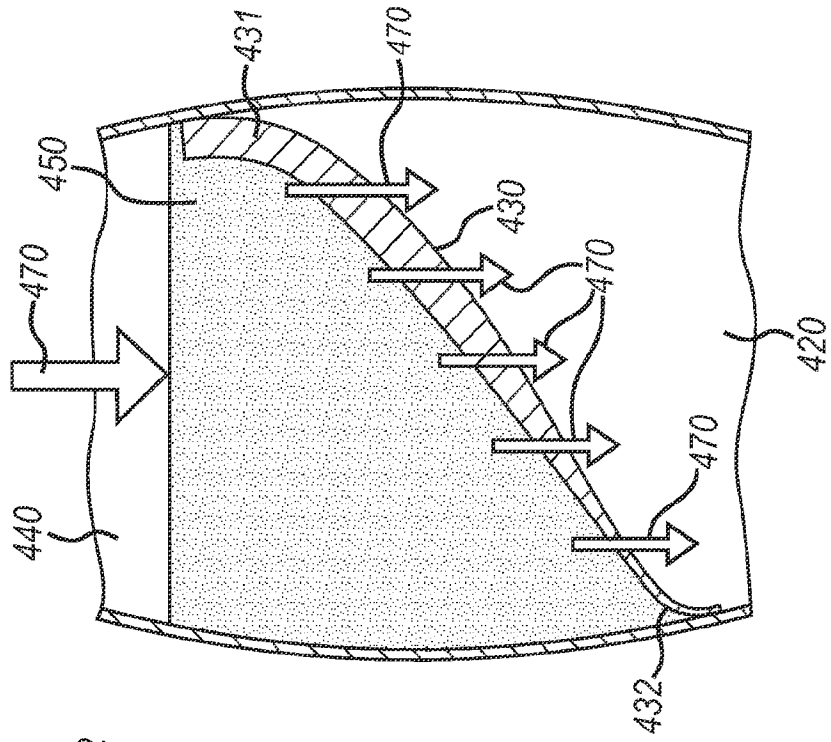

FIG. 8

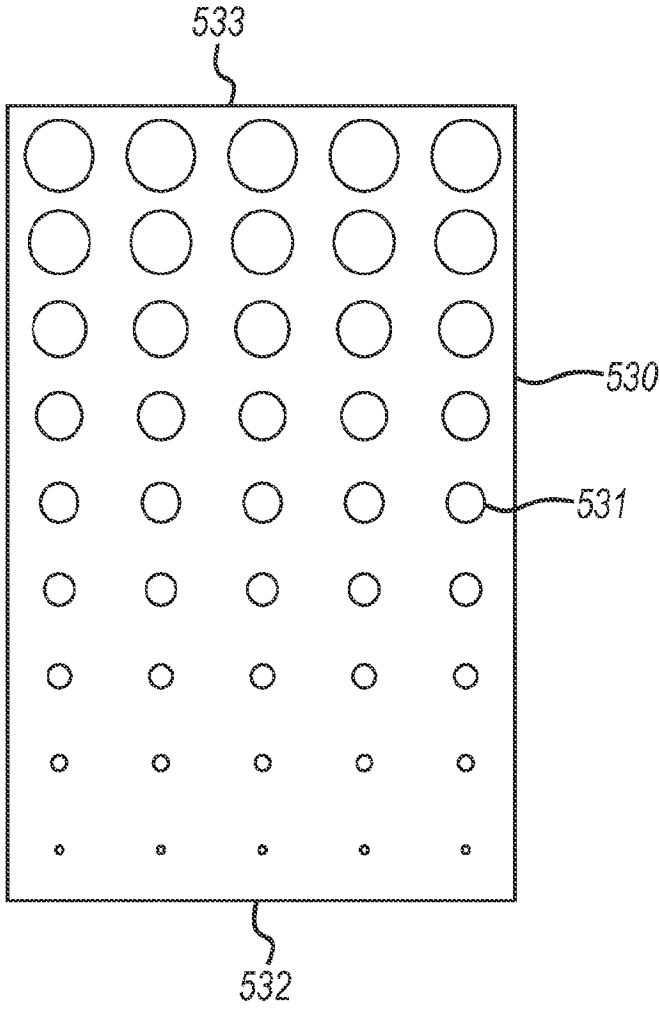

FIG. 9

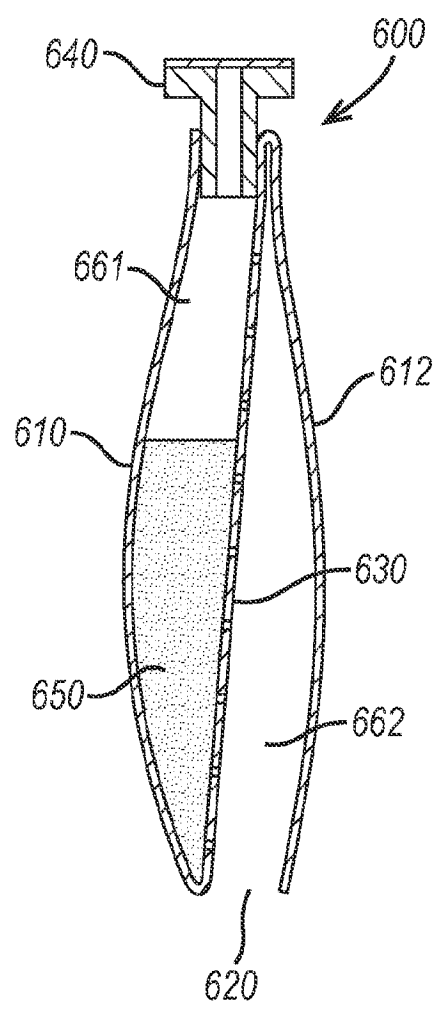

FIG. 10

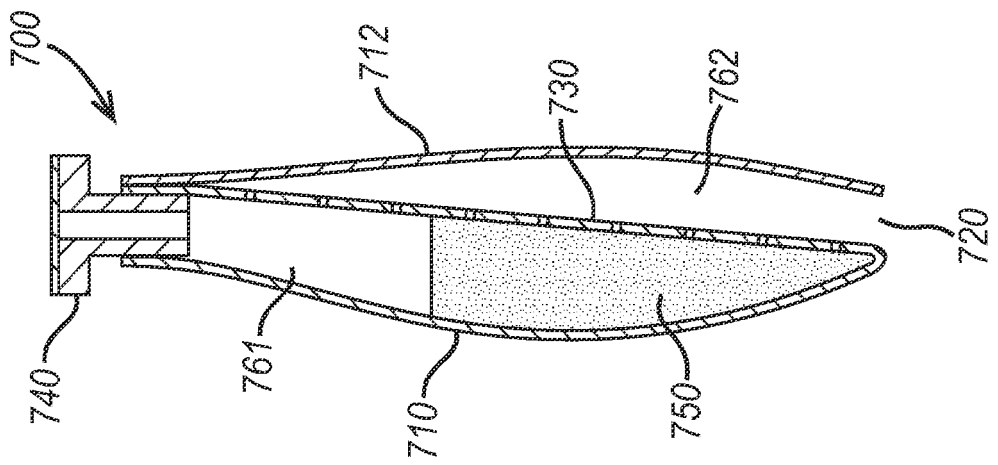
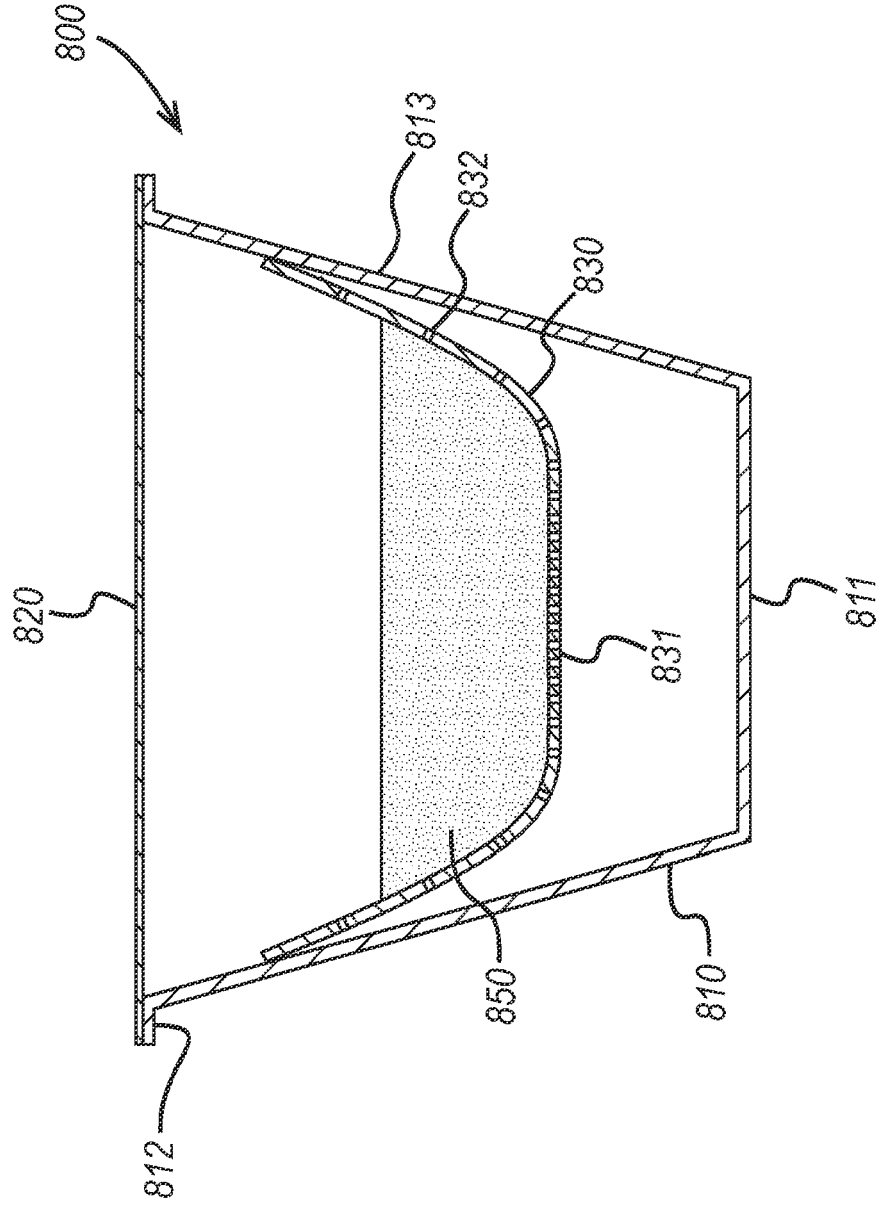

FIG. 11



REFERENCES CITED IN THE DESCRIPTION

This list of references cited by the applicant is for the reader's convenience only. It does not form part of the European patent document. Even though great care has been taken in compiling the references, errors or omissions cannot be excluded and the EPO disclaims all liability in this regard.

Patent documents cited in the description

- WO 9401344 A [0001]
- EP 0512468 A [0001]
- EP 0468079 A [0001]
- US 5840189 A, Keurig [0001]
- EP 0272922 A, Kenco [0001]
- EP 0821906 A, Sara Lee [0001]
- EP 0179641 A [0001] [0003]
- WO 0219875 A, Mars [0001] [0039]
- EP 2100824 A1 [0001]
- EP 2487122 A1 [0001]
- US 2013243910 A1 [0001]
- GB 2121762 A [0001]
- GB 2122881 A [0001]
- EP 0247841 A [0001] [0064]
- WO 9905044 A [0001]
- WO 2005026018 A [0005]