



(11) **EP 3 141 750 B1**

(12) **EUROPEAN PATENT SPECIFICATION**

(45) Date of publication and mention of the grant of the patent:
26.06.2019 Bulletin 2019/26

(51) Int Cl.:
F04B 39/06^(2006.01) F04B 39/12^(2006.01)

(21) Application number: **16188219.6**

(22) Date of filing: **09.09.2016**

(54) **NOISE-REDUCING SHIELDING FOR A DEVICE THAT PRODUCES UNWANTED NOISE**

RAUSCHREDUZIERENDE ABSCHIRMUNG FÜR EINE VORRICHTUNG, DIE UNERWÜNSCHTE GERÄUSCHE ERZEUGT

PROTECTION DE RÉDUCTION DE BRUIT POUR UN DISPOSITIF PRODUISANT UN BRUIT INDÉSIRABLE

(84) Designated Contracting States:
AL AT BE BG CH CY CZ DE DK EE ES FI FR GB GR HR HU IE IS IT LI LT LU LV MC MK MT NL NO PL PT RO RS SE SI SK SM TR

(30) Priority: **09.09.2015 BE 201505567**

(43) Date of publication of application:
15.03.2017 Bulletin 2017/11

(73) Proprietor: **Thercon NV**
2630 Aartselaar (BE)

(72) Inventor: **WAUMANS, Erik**
2880 Bornem (BE)

(74) Representative: **DenK iP**
Hundelgemsesteenweg 1116
9820 Merelbeke (BE)

(56) References cited:
DE-A1- 1 947 152 DE-A1-102011 121 926

EP 3 141 750 B1

Note: Within nine months of the publication of the mention of the grant of the European patent in the European Patent Bulletin, any person may give notice to the European Patent Office of opposition to that patent, in accordance with the Implementing Regulations. Notice of opposition shall not be deemed to have been filed until the opposition fee has been paid. (Art. 99(1) European Patent Convention).

Description

Scope of the invention

[0001] This invention generally relates to noise-reducing shieldings for devices that during their functioning produce unwanted noise, such as for instance heat pumps, generators, fans. More specifically, it relates to a noise-reducing shielding that also guarantees a good ventilation of the device being shielded.

Background of the invention

[0002] Heat pumps are often installed in a garden. The noise generated by these heat pumps is mostly considered a nuisance. Furthermore, there are often noise standards which must not be exceeded. In accordance with the VLAREM (Flemish regulations governing environmental permits) noise standard for example, the noise level on a neighbour's glass façade must be less than 30dB(A).

[0003] In order to reduce the noise coming from the heat pump, noise-reducing shieldings are installed around the heat pump. These noise-reducing shieldings have a dual function. On the one hand, they must reduce the noise coming from the heat pump. On the other hand, they must allow sufficient ventilation. The air flow of heat pumps varies from 1200 to 10000m³/h. The shielding must be able to ventilate this flow.

[0004] An existing shielding around a heat pump is known from DE 19 47 152 A1. In this document, an air-conditioning system and its housing are described with a primary focus on indoor use. The air conditioning system comprising a ventilator and heat exchanging elements that may function as a heat pump is arranged in a box-shaped chamber. A separating wall divides the chamber into two air ways allowing for separate cooling and heating of the air. An air gap situated at the lower side of the separating wall directs the air from the first part of the chamber to the second part, thus leading to a circulation of air through the device. Adjustable slats at the top and upper outer side of the enclosure allow the air to enter and leave the device under a given angle.

[0005] Such a shielding, however, does not provide an optimal way of avoiding unwanted noise created by the air conditioning system. Especially more powerful, and hence noisier, heat pumps may be installed at an outdoor location, e.g. in the garden, and may this way immediately affect neighbours and environment.

[0006] In addition to the existing shieldings, there is room for alternative solutions for shielding heat pumps, whereby the shielding ensures a noise reduction and also enables their ventilation.

Summary of the invention

[0007] An aim of embodiments of the present invention is to provide a good, for example improved, noise shield-

ing for a.o. heat pumps, but in general for devices that produce unwanted noise.

[0008] The preceding aim is achieved by an appliance, device and/or method according to the present invention.

[0009] In a first aspect, the present invention provides a shielding for shielding a device that produces unwanted noise, for instance a heat pump. The shielding comprises:

- 10 - a first stack and a second stack of wing structures, the wing structures in a stack being inter-spaced such that it is possible for air to pass between the wing structures,
- 15 - panels, which may be installed such that, together with the first stack and second stack, they form a chamber in which the device, e.g. the heat pump, may be installed,
- 20 - a separation plate, which may be installed such that it subdivides the chamber into a first part and a second part such that the first stack of wing structures is located in the first part and the second stack of wing structures is located in the second part, the separation plate being provided with an opening to provide a passage for the air entry or air exit of the device, e.g. the heat pump, whereby noise-insulating material is incorporated into or attached to the wing-structures.

[0010] It is an advantage of embodiments of the present invention that they reduce the noise of a device, e.g. a heat pump by the presence of the wing structures and that they simultaneously allow sufficient ventilation of the device, e.g. heat pump by providing that it is possible for air to pass between the wing structures. It is an advantage of embodiments of the present invention that the noise of the device, e.g. heat pump is reduced by at least 3dB or even 6dB. It is an advantage of embodiments of the present invention that an air flow through the shielding of more than 1200m³/h, more than 5000m³/h or even more than 10000m³/h is possible. The noise characteristic of the noise produced by the device, e.g. heat pump may be dependent on the operation mode of the device, e.g. heat pump. It is an advantage of embodiments of the present invention that, due to the shape of the wing structure and/or a hybrid construction of the wing structure, the band width of the noise being reduced may be increased by the shielding. Furthermore, this also enables the noise reduction to be increased. By inter-spacing the wing structures in stack direction, it is made possible for air to pass between the wing structures in a stack. It is an advantage of embodiments of the present invention that internal circulation within the chamber formed by the stacks of wing structures and the panels is prevented. The separation plate is provided with an opening to provide a passage of the air entry or the air exit of the device, e.g. heat pump. As such, device, e.g. heat pump, and air entry or air exit are located in the first part of the chamber, whereas the air exit or air entry is located in the second

part of the chamber, or vice versa. Due to the presence of the separation plate between the air entry side and the air exit side of the device, e.g. heat pump, it is prevented that air circulates directly between the entry side and the exit side of the device, e.g. heat pump without exiting the shielding via the wing structure. It is an advantage of embodiments of the present invention that the air flow is forced to enter or exit the chamber via the wing structures. This is made possible by positioning the panels such that they close off the chamber in those positions where no wing structures are present and due to the separation plate between the air entry side and the air exit side of the device, e.g. heat pump.

[0011] In a shielding according to embodiments of the present invention, the wing structures may comprise noise-insulating material.

[0012] The wing structures may be made from acoustically insulating material, or acoustically insulating material, for example a layer of acoustically insulating material, may have been added. It is an advantage of embodiments of the present invention that noise-insulating material enables a greater reduction of the noise, without reducing the potential air passage.

[0013] In a shielding according to embodiments of the present invention, the noise-insulating material may be clamped into the wing structures by means of springs.

[0014] It is an advantage of embodiments of the present invention that the noise-insulating material may be installed in a simple manner.

[0015] In a shielding according to embodiments of the present invention, recesses may be present in the extremities of the wing structures such that, when the wing structures are stacked, the panels may be slid into the recesses.

[0016] The recesses may for example be U-shaped recesses. It is an advantage of embodiments of the present invention that the panels may be installed without requiring associated profiles for these. Also, specific tools for mounting are not required either.

[0017] In a shielding according to embodiments of the present invention, the wing structures may have a raised lip which, when the wing structures are stacked, is located to the side of the wing structures closest to the chamber formed, and which guides any air flow aerodynamically through the chamber to the remainder of the wing structure.

[0018] It is an advantage of embodiments of the present invention that the resistance encountered by the air when it passes through the wing structures is smaller due to fitting a raised lip to the inside of the wing structures.

[0019] In a shielding according to embodiments of the present invention, the separation plate may be dimensioned such that it may be fixed against the air entry side or the air exit side of the device, e.g. heat pump and that openings may be made into the separation plate such that, when fixed, the separation plate does not hinder the air flow through the device, e.g. heat pump.

[0020] It is an advantage of embodiments of the present invention that no extra support is required to fix the separation plate.

[0021] In a shielding according to embodiments of the present invention, the wing structures may be provided with a mounting profile such that a first side of the mounting profile of a first wing structure may be slid into a second side of the mounting profile of a second wing structure.

[0022] It is an advantage of embodiments of the present invention that the wing structures may be interspaced at a set, predetermined distance between them. It is an advantage of embodiments of the present invention that no separate profiles are required to stack the wing structures one on top of the other.

[0023] In a shielding according to embodiments of the present invention, the mounting profile may be provided with a click system such that the one mounting profile may be clicked onto the other mounting profile.

[0024] It is an advantage that the profiles are sturdily stuck one on top of the other thus increasing the sturdiness of the shielding, which is beneficial for example in strong winds.

[0025] Specific and preferable aspects of the invention have been included in the attached independent and dependent claims. Features of the dependent claims may be combined with features of the independent claims and with features of other dependent claims such as indicated and not only as expressly brought forward in the claims.

[0026] These and other aspects of the invention will be apparent from and be clarified by reference to the embodiment(s) described below.

Short description of the drawings

[0027]

FIG. 1 shows a schematic 3D view of a shielding according to embodiments of the present invention.

FIG. 2 shows a schematic cross-section (3D view) of a shielding according to embodiments of the present invention.

FIG. 3 shows the same view as FIG. 2 but of a shielding with a lower height, according to embodiments of the present invention.

FIG. 4 shows a top view of a shielding according to embodiments of the present invention.

FIG. 5 shows a 3D view of a wing structure according to embodiments of the present invention.

FIG. 6 shows a side view of a wing structure according to embodiments of the present invention.

FIG. 7 shows a rear view of a wing structure according to embodiments of the present invention.

FIG. 8 shows a top view of a wing structure according to embodiments of the present invention.

FIG. 9 shows a bottom view of a wing structure according to embodiments of the present invention.

FIG. 10 shows a spring of a wing structure according

to embodiments of the present invention.

FIG. 11 shows a cross-section of a wing structure according to embodiments of the present invention.

FIG. 12 is a 3D drawing of a wing structure according to embodiments of the present invention.

[0028] The figures are only schematic and not restrictive. It is possible that the dimensions of some components have been exaggerated and have not been represented to scale in the figures for illustrative purposes.

[0029] Reference numbers used in the claims cannot be interpreted to restrict the scope of protection. In the various figures, the same reference numbers refer to the same or similar elements.

Detailed description of illustrative embodiments

[0030] The present invention will be described in respect of special embodiments and with reference to certain drawings, however the invention will not be restricted to this but will only be restricted by the claims. The drawings described are only schematic and not restrictive. In the drawings, the dimensions of some elements have been enlarged and have not been drawn to scale for illustrative purposes. The (relative) dimensions sometimes do not correspond with the up-to-date practical embodiment of the invention.

[0031] The terms first, second, third and the like in the description and in the claims are used to distinguish similar elements and are not necessarily used for describing an order, nor in time, nor in space, nor in ranking nor in any other manner. It should be understood that the terms used in this way are interchangeable in appropriate circumstances and that the embodiments of the invention described are suitable to work in a different order than described or indicated here.

[0032] Furthermore, the terms top, bottom, above, in front of and the like used in the description and the claims are used for description purposes and not necessarily to describe relative positions. It should be understood that the terms used as such are interchangeable in given circumstances and that the embodiments of the invention described herein are also suitable for functioning according to different orientations than described or indicated here.

[0033] It should be noted that the term "comprises", as used in the claims, should not be interpreted as being restricted to the items described thereafter; this term does not exclude any other elements or steps. It may be interpreted as specifying the presence of the features, values, steps or components indicated which are referred to but does not exclude the presence or addition of one or several other features, values, steps or components, or groups thereof. So, the extent of the expression "a device comprising items A and B" should not be restricted to devices consisting of components A and B only. It means that in respect of the present invention, A and B are the only relevant components of the device.

[0034] Reference throughout this specification to "one embodiment" or "an embodiment" means that a specific feature, structure or characteristic described in connection with the embodiment has been included in at least one embodiment of the present invention. So, the occurrence of the expressions "in one embodiment" or "in an embodiment" in various locations throughout this specification do not necessarily need to refer to the same embodiment all the time, but can do so. Furthermore, the specific features, structures or characteristics may be combined in any suitable manner as would be clear to a person skilled in the art on the basis of this publication, in one or several embodiments.

[0035] Similarly, it should be appreciated that in the description of sample embodiments of the invention, various features of the invention are sometimes grouped together in one single embodiment, figure or description thereof intended to streamline the publication and to help the understanding of one or several of the various inventive aspects. This method of publication should therefore not be interpreted as a reflection of an intention that the invention requires more features than explicitly mentioned in each claim. Rather, as the following claims reflect, inventive aspects lie in fewer than all features of one single previously publicised embodiment. So, the claims following on from the detailed description have been explicitly included in this detailed description, with every independent claim being a separate embodiment of the invention.

[0036] Furthermore, while some embodiments described herein comprise some, but not other, features included in other embodiments, combinations of features from various embodiments are intended to be within the scope of the invention, and form these various embodiments as would be understood by the person skilled in the art. For example, in the following claims, any of the embodiments described may be used in any combination.

[0037] In the description provided here, a large number of specific details are raised. It may therefore be understood that embodiments of the invention may be embodied without these specific details. In other cases, well-known methods, structures and techniques are not shown in detail in order to keep this description clear.

[0038] In the detailed description, a shielding of a heat pump is described in more detail. The invention is, however, not limited to shieldings for heat pumps, but may be applied in its most general form for shieldings of devices that produce unwanted noise, especially such devices which simultaneously also need to be ventilated or cooled, for example, a generator or a fan.

[0039] Where reference is made in embodiments to the "inside of the wing structure", the side is meant that is located on the inside of the chamber formed by the wing structures and the panels.

[0040] Where reference is made in embodiments to the "outside of the wing structure", the side is meant that is located on the outside of the chamber formed by the

wing structures and the panels.

[0041] Where reference is made in embodiments of the present invention to "the inter-spacing between two wing structures", the distance is meant between a first wing structure and a second wing structure stacked on top of it. This distance is measured perpendicular to the wing surface of both wing structures. When this distance differs depending on the position between the two wing structures, an average distance is taken.

[0042] In a first aspect, the present invention relates to a shielding 100 that may be used to shield a heat pump 120. Instead of for a heat pump, the shielding 100 may for example also be used to shield a generator or a fan. The function of this shielding 100 is to reduce the noise generated by the heat pump 120. The shielding 100 simultaneously allows sufficient ventilation of the heat pump 120.

[0043] Embodiments of the present invention comprise wing structures 110 which may be stacked one on top of the other. Between the wing structures 110, there is an open air space such that air may pass through the stacked wing structure. In a practical embodiment, in which the heat pump 120, the generator or the fan, is arranged vertically, and therefore occupies a predetermined height, also the wing structures 110 are placed in a vertical stack on one another. The stack is preferably at least as high as the height of the heat pump 120, generator or fan.

[0044] In one preferable embodiment, the wing structures 110 have an equal shape. Due to the stackability of the wing structures 110, a modularly constructed shielding 100 is achieved. The modularity ensures that the shielding 100 may be adjusted to the height of the heat pump 120 or the appliance the noise of which needs to be reduced.

[0045] In embodiments of the present invention, a first series of these wing structures 110 is stacked to the air entry side 122 of the heat pump 120 (the first stack 112) and a second series of these wing structures 110 is stacked to the air exit side 124 of the heat pump (the second stack 114). Both stacks of wing structures may be installed such that, together with side panels 140, 142, and top panel 150, they form a chamber. The panels delimit the chamber where no stacks 112, 114 of wing structures 110 are present. An example of a shielding 100 corresponding with an embodiment of the present invention is shown in FIG. 1. In this figure, the shielding 100 has been presented transparent such that the heat pump 120 being shielded is visible too. However, in reality, the shielding will be made from an opaque material, for example an opaque plastic, typically a hard plastic. In embodiments of the present invention, the wing structures are for example made by means of an injection mould. The wing structures may for example be made from talc-reinforced polypropylene (PP talc), HDPE (high-density polyethylene), or ABS (acrylonitrile butadiene styrene). An advantage of talc-reinforced polypropylene is that it is stiffer and more UV-resistant than for

example HDPE and ABS. The side panels 140, 142 and top panel 150 may be made from the same material as the wing structures 110, although this is not essential.

[0046] The size of the chamber may be chosen such that the heat pump 120 fits into it. By adding wing structures 110, the height of the chamber may be increased (also see FIG. 2 for an indication of the height h of the chamber). For example, more than three wing structures or more than seven wing structures may be stacked one on top of the other. The dimensions (length and width) of the wing structures 110 and of the panels 140, 142, 150 determine the length and the width of the chamber (also see FIG. 4 for an indication of the length l and width w of the chamber). In embodiments of the present invention, the length l of a wing profile may be between 75cm and 2m, preferably between 1m and 1.5m, preferably approximately 1.15m.

[0047] In embodiments according to the present invention, both stacks 112, 114 of wing structures 110 are installed in parallel. In such case, a panel 140 may be installed to one side between the stacks 112, 114, a second panel 142 may be installed to the other side between the stacks 112, 114. These are the side panels 140, 142. A third panel 150 may be installed to the top side of the stacks 112, 114. The panel 150 installed to the top side must be sufficiently sturdy to withstand an external pressure load; for example, it must be able to carry a layer of snow. For this, use is made preferably of panels with a torsional rigidity high enough to be able to carry such load, for example the layer of snow. For the panels, use may be made for example of sandwich panels with a waffle structure in between. The panels are preferably noise-reducing. This ensures an extra noise reduction, in addition to the reduction already achieved by the wing structures. The panels are preferably moisture-resistant, as they are mostly intended for outdoor use. They preferably have a smooth external surface, preventing contamination and for example moss growth. The construction of a shielding 100 according to embodiments of the present invention, as described above, is shown in FIG. 1 to FIG. 3.

[0048] In embodiments of the present invention, the distance between a first stack 112 of wing structures and a second stack 114 of wing structures (e.g. the width w in FIG. 4) is between 40cm and 100cm, preferably between 50cm and 80cm. This distance is at least such that the heat pump or a different appliance the noise of which is to be reduced, will fit into the shielding. In the example of FIG. 4 showing a top view of a shielding according to embodiments of the present invention, the distance is determined by the width w of the side panels 140, 142. This figure also shows recesses 180 in the wing structures 110 in which the side panels 140, 142 have been slid. The first stack 112 and the second stack 114 are formed by clicking the wing structures 110 one onto the other by means of the mounting profiles 220. The shielding 100 formed may be closed off along the top by installing a top panel 150 onto the mechanical fixing points

410 and fixing it using for example a click system or different mechanical connection, for example screws. The wing structures 110 are provided with a raised lip 230 to the inside in order to achieve a more aerodynamic profile.

[0049] A shielding 100 according to embodiments according to the present invention comprises a separation plate 210, as illustrated in FIG. 3. This may be installed in the space formed between the first stack 112 and the second stack 114. This may be installed such that it subdivides the space into two parts: a first part 162 comprising the first stack 112 and the air entry side 122 of the heat pump 120 and a second part comprising the second stack 114 and the air exit side 124 of the heat pump 120. An example of said separation plate 210 can be seen in FIG. 2 and in FIG. 3. This separation plate 210 ensures that the suctioned air enters the space via the first stack 112 of wing structures 110 and exits the space via the second stack 114 of wing structures 110. For the air flow, space has been left between the wing structures 110 stacked one on top of the other. The inter-spacing between two wing structures stacked one on top of the other is indicated in FIG. 3 by *dws*. This is the perpendicular distance between the top surface of the bottom wing structure and the bottom surface of the higher-positioned wing structure. In embodiments of the present invention, this distance is between 2cm and 8cm, preferably between 3cm and 6cm, preferably approximately 42mm. The inter-spacing between two wing structures stacked one on top of the other determines both the air flow and the noise reduction: the greater the air flow is, the worse the noise reduction is. The inter-spacing between two wing structures stacked one on top of the other therefore needs to be optimised. The separation plate 210 prevents that air circulates internally inside the chamber. In other words, it ensures that a direct circulation between the air entry side 122 and the air exit side 124 of the heat pump 120 is prevented. The separation plate 210 may for example be fixed against the heat pump 120, for example against the air exit side 124 or against the air entry side 122 of the heat pump 120. Hereby, openings are provided in the separation plate 210 such that the air passing through the heat pump 120 is not prevented. In embodiments according to the present invention, the separation plate 210 is fixed against the heat pump 120 by means of a fixing mechanism. This may for example constitute screws or rivets, possibly also Velcro or a similar easily detachable fixing system may be used. It is an advantage of embodiments of the present invention that the fixing mechanism is not made from corrosive material. This prevents corrosion to the heat pump, caused by the fixing mechanism. The separation plate 210 may be made from different materials such as wood, metal, plastic. Use is preferably made of a plastic separation plate 210 having a waffle structure. Use is preferably made of a separation plate 210 into which openings may easily be made. If the openings may easily be made, the installer, depending on the type of heat pump 120 being installed, may be able to make openings in the separation plate 210 in the

suitable position(s). This eliminates the need to have to make a suitable separation plate 210 with openings preformed in advance corresponding to each type of heat pump.

[0050] In embodiments of the present invention, the bottom wing structures 110 are installed on a base 190. This base 190 additionally ensures the sturdiness of the shielding 100. This may for example be achieved by anchoring the base 190 to the ground. An example of a base 190 can be seen in FIG. 1, FIG. 2 and FIG. 12. Depending on the subsurface, a different base 190 may be required onto which the shielding 100 may be installed. A floor plate may possibly be fitted too onto which the shielding may be mounted (e.g. if the heat pump is installed on a flat roof). This floor plate may be made from a suitably sturdy material. The floor plate may for example be a metal floor plate, or a floor plate from hard plastic.

[0051] FIG. 5 shows a 3D drawing of a wing structure 110 according to embodiments of the present invention. In this embodiment, the enveloping outer periphery of the wing structure is substantially trapezoidal. In particular embodiments, the enveloping outer periphery of the wing structure may be substantially rectangular or substantially triangular. The wing structure has a partially hollow interior where there is room for sound-absorbing insulation material, for example, sound-insulating plates, such as for example, sheets of rock wool or glass wool.

[0052] For the installation of the top panel 150, mechanical fixing points 410 are provided to the inside of the wing structure, onto which the top panel 150 may be fixed. These may for example be surfaces onto which the top panel 150 may rest and onto which it may be screwed. These surfaces may be reinforced at the bottom side by (rounded) reinforcement ribs 520. In principle, a wing structure 110 with such fixing points 410 may only be required for the top layer of the first stack 112 and second stack 114. However, it is particularly favourable to provide said fixing points 410 in each wing structure 110, even if they are not used in the lower positioned layers in the first and second stacks 112, 114, as then only one type of wing structures 110 will need to be provided for the construction of a well-determined shielding 100.

[0053] In embodiments of the present invention, at least one mounting profile 220 is present on the wing structures 110. This may for example be to the inside of the wing structures 110. This mounting profile 220 has a first side that may be slid into the second side of the mounting profile of a different wing structure when stacking the wing structures 110. The mounting profiles 220 may for example be provided with a click system such that the one mounting profile clicks into the other profile in a certain position. In embodiments of the present invention, there are between 2 and 5 mounting profiles 220 per wing structure present, for example 3 mounting profiles (as is the case in the wing structure illustrated in FIG. 5). These mounting profiles 220 may, but do not need to, be inter-spaced at equal distances one from the

other.

[0054] In embodiments of the present invention, reinforcement plates 130 are present to the sides of the wing structures 110. An example of this is shown in FIG. 5. These reinforcement plates partially slide one over the other when stacking the wing structures 110. Because of these reinforcement plates 130, the sides of the stacks of wing structures 110 are closed off such that the air may only flow between the wing structures and not along the sides. As a result, a better air flow and a better noise reduction may be achieved. The reinforcement plates 130 also provide a neat finish to the sides of the shielding 100. These reinforcement plates 130 are possibly provided with an indentation 134 and a protrusion 132. The indentation 134 may also be an opening in the reinforcement plate 130. The indentations 134 and protrusions 132 are positioned such that the protrusion 132 of a reinforcement plate 130 on the one wing structure 110 clicks into the indentation 134 of a reinforcement plate 130 on the other wing structure 110 when the wing structures 110 are stacked one on top of the other (this is the case in the example of FIG. 1). As a result, a sturdier stacking of wing structures 110 is achieved. A slot 136 is possibly provided along the protrusion 132 and/or along the indentation 134. This slot 136 ensures that the reinforcement plates 130 near the slot 136 are better moveable such that the interlocking between the protrusion 132 and the indentation 134 may be disconnected more easily, for example if maintenance of the heat pump 120 requires dismantling of the shielding 100.

[0055] In embodiments of the present inventions, the extremities of the wing structures are provided with a U-shaped recess 180 to the inside of the wing structure 110. When the wing structures 110 are stacked, these U-shaped recesses 180 are in a straight line such that it is possible to slide a side panel 140, 142 into them. In embodiments of the present invention, the width of these U-shaped recesses are between 0.2cm and 2 cm, preferably between 0.5cm and 1cm and preferably correspond with the thickness of the panels 140, 142 that must be slid into them. The thickness of the panels 140, 142 may for example be 11mm and these may for example be slid into U-shaped recesses with a 16mm width. The width of these recesses 180 preferably correspond with the thickness of the side panels 140, 142 such that the side panels 140, 142 may be installed without associated fixing means.

[0056] In embodiments of the present invention, such as for example in FIG. 5, the U-shaped recesses are formed by leaving a spacing between a reinforcement plate 130 and the nearest mounting profile 220.

[0057] When stacked, the top side of a wing structure 110 forms an angle α with the perpendicular formed on the wall by the stack 112, 114 of wing structures 110. When the wing structures 110 are stacked in a vertical stack, the angle α is locked in between the top side of the wing structure 110 and a horizontal. In embodiments of the present invention, this angle α is between 10° and

50°, preferably between 20° and 40°. An example of this is shown in FIG. 6. Hereby, it is an advantage that due to the angle α formed, the noise of the heat pump 120 is reduced by the wing structures 110 whereas a ventilation of the heat pump 120 remains possible by the presence of the openings between the wing structures 110. In embodiments of the present invention, it is furthermore an advantage that the angle α under which the wing structures 110 are installed is such that there is no view into the inside of the shielding 100 from outside. When installed around a heat pump 120, the wall formed by stacking the wing structures 110 is preferably in parallel to a raised side of the heat pump (quasi vertical stacking direction and quasi horizontal wing structures) and the wing structures are preferably oriented downwards (leaving from the heat pump to the outside).

[0058] The top side of the wing structure 110 is the side that is positioned at the top when the wing structures 110 are stacked to form a shielding 100. In embodiments of the present invention, this top side has a length (d in FIG. 6), measured across the top side from the inside to the outside of the wing structure, that is between 10cm and 50cm, preferably between 20 and 40cm preferably 30cm. By increasing the length of the wing structure 110, the noise reduction of it may be increased.

[0059] In embodiments of the present invention, there is a raised lip 230 to the inside of the wing structures 110 to better guide the air flow coming from or going to the heat pump 120. The longitudinal direction of the raised lip 230 is oriented in the longitudinal direction of the wing structures 110. In embodiments of the present invention there is an angle between a perpendicular to the wall, formed by a stack of wing structures 110, and the raised lip 230 locked in between them that is between 10° and 50°, preferably between 20° and 40°. The raised lip 230 ensures a lowered air resistance of the air flow profile of the wing structure 110. It is an advantage of embodiments of the present invention that, due to this raised lip, it is prevented that a hand, in particular for example a child's hand, may reach through the shielding up to the heat pump. This offers the additional advantage that the fan protection of the heat pump may be removed such that the heat pump produces less noise during its operation and that pressure loss is reduced (the pressure loss caused by the fan protection). It is an advantage of embodiments of the present invention that the overall air resistance through the shielding 100 is lower than in some existing shieldings. This air resistance is optimised by the shape of the wing structure 110. In some existing systems, the air flow is guided through an inter-space, such that the air flow is subject to turbulence due to the air flow bouncing against the walls of the inter-space. Conversely, the wing structures 110 of the present arrangement have a more aerodynamic profile such that they have a smaller air resistance.

[0060] In embodiments of the present invention, at least one fin 510 is installed to the inside of the wing structures, the longitudinal direction of which has the

same direction as the stacking direction of the wing structures 110 (see FIG. 5, FIG. 7, and FIG. 9). The width (b in FIG. 9) of such a fin 510 may be between 15mm and 100mm, preferably between 40mm and 90mm. By positioning the fin in the transverse direction according to a certain angle (α in FIG. 9), the air flow through the stacked wing structures 110 may be optimised in function of the desired flow and in function of the noise requirements (e.g. how much noise reduction is required). Furthermore, these fins (among other things), in embodiments of the present invention, ensure that it is not possible to reach the heat pump through the shielding with a hand. The angle α is the angle formed between the surface formed by the stacked wing structures and the surface of the fin 510. This angle may vary from fin to fin.

[0061] In embodiments of the present invention, the noise of the heat pump 120 may be reduced even more by installing noise-insulating material 1110, for example glass wool, rock wool, polyester wool, melamine foam or eggbox profile foam, into the wing structures 110 and/or by making the wing structures from noise-insulating material and/or by increasing the distance (d) from the top side of the wing structures 110 measured from the inner side to the outside. In embodiments of the present invention, a combination of noise-reducing materials is used (e.g. a hybrid construction of the wing structure) such that both higher and lower frequencies may be reduced.

[0062] In embodiments of the present invention, the wing structures 110 have been provided with hollow spaces in which the noise-insulating material 1110 may be installed. These spaces may be formed by ribs 710 present in the wing structure 110. The noise-insulating material 1110 may be clamped between the ribs 710 by means of springs 720.

[0063] An example of this can be seen in FIG. 7. The ribs 710 are perpendicular to the wing structure 110 and divide the wing structure 110 into several spaces. In embodiments of the present invention, the ribs 710 have been installed such that spaces of equal size are achieved. The ribs 710 may have springs 720 mounted onto them. The insulation material 1110 may be clamped between these springs 710.

[0064] FIG. 8 shows a top view of the same wing structure 110 as the one of which the rear view is shown in FIG. 7. In this figure, the U-shaped recess 180 formed by the reinforcement plate 130 and the adjacent mounting profile 220 can be seen. To both sides of the middle mounting profile 220, a raised lip 230 is visible too.

[0065] FIG. 9 shows a bottom view of a wing structure according to embodiments of the present invention. In here, the ribs 710 and the springs 720 can be seen. The wing structure from FIG. 9 has U-shaped recesses 180 between the reinforcement panels 130 and the mounting profiles 220 as well as fins 510 for a better air guidance.

[0066] An example of a spring 720 for clamping insulation material 1110 into a wing structure 110 according to embodiments of the present invention, is shown in FIG. 10.

[0067] FIG. 11 shows a cross-section of a wing structure 110 according to embodiments of the present invention. In this figure, the insulation material 1110 can be seen that is fitted against the wing structure 110 between the ribs 710 and clamped by means of springs 720. In the background of this figure, a reinforcement plate 130 can be seen with an indentation 134 in it in which a protrusion 132 may be clicked when stacking the wing structures 110. In the figure, a mounting profile 220 can be seen too which may be slid and clicked into the mounting profile of a wing structure 110 underneath.

[0068] FIG. 12 shows a 3D drawing of a shielding 100 according to embodiments of the present invention. The figure shows stacks of wing structures 110 which together with the panels 140, 150 form a closed-off space. The shielding 100 is fixed to a base 190 which may possibly be anchored into the ground.

[0069] The various aspects can easily be combined, and the combinations will also correspond with embodiments according to the present invention.

Claims

1. A shielding (100) for shielding a device that produces unwanted noise (120), the shielding (100) comprising:

- a first stack (112) and a second stack (114) of wing structures (110), the wing structures (110) in a stack being inter-spaced such that it is possible for air to pass between the wing structures (110),

- panels (140, 142, 150), which may be installed such that, together with the first stack (112) and second stack (114), they form a chamber in which the device (120) may be installed,

- a separation plate (210), which may be installed such that it subdivides the chamber into a first part (162) and a second part (164) such that the first stack of wing structures (112) is located in the first part (162) and the second stack of wing structures (114) is located in the second part (164), the separation plate (210) being provided with an opening to provide a passage for the air entry or air exit of the device (120),

characterized in that noise-insulating material is incorporated into or attached to said wing-structures (110).

2. The shielding (100) according to claim 1, the noise-insulating material being clamped into the wing structures (110) by means of springs.

3. The shielding (100) according to one of the preceding claims, with recesses (180) being present in the

extremities of the wing structures (110) such that, when the wing structures (110) have been stacked, the panels (140, 142) may be slid into the recesses.

4. The shielding (100) according to one of the preceding claims, the wing structures (110) having a raised lip (230) which, when the wing structures (110) are stacked, is located to the side of the wing structures (110) closest to the chamber formed, and which guides any air flow aerodynamically through the chamber to the remainder of the wing structure.
5. The shielding (100) according to one of the preceding claims, the separation plate (210) being dimensioned such that it may be fixed against the air entry side (122) or against the air exit side (124) of the device (120) and openings being made in the separation plate (210) such that, which fixed, the separation plate does not hinder the air flow through the device (120).
6. The shielding (100) according to one of the preceding claims, the wing structures (110) being provided with a mounting profile (220) such that a first side of the mounting profile (220) of a first wing structure (110) may be slid into a second side of the mounting profile (220) of a second wing structure (110).
7. The shielding (100) according to claim 6, the mounting profile (220) being provided with a click system such that the one mounting profile may be clicked onto the other mounting profile.

Patentansprüche

1. Abschirmung (100) zum Abschirmen einer Vorrichtung, die unerwünschte Geräusche (120) erzeugt, wobei die Abschirmung (100) umfasst:
 - einen ersten Stapel (112) und einen zweiten Stapel (114) Flügelstrukturen (110), wobei die Flügelstrukturen (110) in einem Stapel voneinander beabstandet sind, sodass es für Luft möglich ist, zwischen den Flügelstrukturen (110) durchzutreten,
 - Platten (140, 142, 150), die installiert werden können, sodass sie zusammen mit dem ersten Stapel (112) und zweiten Stapel (114) eine Kammer bilden, in der die Vorrichtung (120) installiert werden kann,
 - ein Trennblech (210), das installiert werden kann, sodass es die Kammer in einen ersten Teil (162) und einen zweiten Teil (164) unterteilt, sodass sich der erste Stapel Flügelstrukturen (112) im ersten Teil (162) befindet, und sich der zweite Stapel Flügelstrukturen (114) im zweiten Teil (164) befindet, wobei das Trennblech (120)

mit einer Öffnung versehen ist, um einen Durchtritt für den Lufteinlass oder Luftauslass der Vorrichtung (120) bereitzustellen,

- 5 **dadurch gekennzeichnet, dass** geräuschisolierendes Material in die Flügelstrukturen (110) integriert oder an denselben angebracht ist.
- 10 2. Abschirmung (100) nach Anspruch 1, wobei das geräuschisolierende Material mittels Federn in die Flügelstrukturen (110) geklemmt ist.
- 15 3. Abschirmung (100) nach einem der vorstehenden Ansprüche, mit Vertiefungen (180), die in den Enden der Flügelstrukturen (110) vorhanden sind, sodass wenn die Flügelstrukturen (110) gestapelt wurden, die Platten (140, 142) in die Vertiefungen eingeschoben werden können.
- 20 4. Abschirmung (100) nach einem der vorstehenden Ansprüche, wobei die Flügelstrukturen (110) eine hochgezogene Lippe (230) aufweisen, die sich, wenn die Flügelstrukturen (110) gestapelt sind, auf der Seite der Flügelstrukturen (110) befindet, die der gebildeten Kammer am nächsten liegt, und die jede Luftströmung aerodynamisch durch die Kammer hindurch zum Rest der Flügelstruktur leitet.
- 25 5. Abschirmung (100) nach einem der vorstehenden Ansprüche, wobei das Trennblech (210) bemessen ist, sodass es an der Lufteinlassseite (112) oder an der Luftauslassseite (124) der Vorrichtung (120) befestigt werden kann, und wobei Öffnungen im Trennblech (210) angefertigt sind, sodass wenn das Trennblech befestigt ist, es die Luftströmung durch die Vorrichtung (120) hindurch nicht behindert.
- 30 6. Abschirmung (100) nach einem der vorstehenden Ansprüche, wobei die Flügelstrukturen (110) mit einem Montageprofil (220) versehen sind, sodass eine erste Seite des Montageprofils (220) einer ersten Flügelstruktur (110) in eine zweite Seite des Montageprofils (220) einer zweiten Flügelstruktur (110) eingeschoben werden kann.
- 35 7. Abschirmung (100) nach Anspruch 6, wobei das Montageprofil (220) mit einem Klicksystem versehen ist, sodass das eine Montageprofil an das andere Montageprofil geklickt werden kann.

Revendications

1. Protection (100) pour protéger un dispositif qui produit du bruit indésirable (120), la protection (100) comprenant :
 - une première pile (112) et une seconde pile

(114) de structures d'aile (110), les structures d'aile (110) d'une pile étant inter-espacées de telle sorte qu'il est possible pour l'air de passer entre les structures d'aile (110),

- des panneaux (140, 142, 150), qui peuvent être installés de telle sorte que, avec les première pile (112) et seconde pile (114), ils forment une chambre dans laquelle le dispositif (120) peut être installé,

- une plaque de séparation (210), qui peut être installée de telle sorte qu'elle subdivise la chambre en une première partie (162) et en une seconde partie (164) de telle sorte que la première pile de structures d'aile (112) est située dans la première partie (162) et la seconde pile de structures d'aile (114) est située dans la seconde partie (164), la plaque de séparation (120) étant pourvue d'une ouverture pour fournir un passage pour l'entrée d'air ou la sortie d'air du dispositif (120),

caractérisée en ce qu'un matériau d'insonorisation est incorporé dans lesdites structures d'aile (110) ou attaché à celles-ci.

2. Protection (100) selon la revendication 1, le matériau d'insonorisation étant serré dans les structures d'aile (110) à l'aide de ressorts.

3. Protection (100) selon l'une quelconque des revendications précédentes, des évidements (180) étant présents dans les extrémités des structures d'aile (110) de telle sorte que, quand les structures d'aile (110) ont été empilées, les panneaux (140, 142) peuvent être glissés dans les évidements.

4. Protection (100) selon l'une quelconque des revendications précédentes, les structures d'aile (110) ayant un rebord surélevé (230) qui, quand les structures d'aile (110) sont empilées, est situé sur le côté des structures d'aile (110) le plus proche de la chambre formée, et qui guide tout écoulement d'air de façon aérodynamique à travers la chambre jusqu'au reste de la structure d'aile.

5. Protection (100) selon l'une quelconque des revendications précédentes, la plaque de séparation (210) étant dimensionnée de telle sorte qu'elle peut être fixée contre le côté d'entrée d'air (122) ou contre le côté de sortie d'air (124) du dispositif (120) et des ouvertures étant créées dans la plaque de séparation (210) de telle sorte que, une fois fixée, la plaque de séparation n'entrave pas l'écoulement d'air à travers le dispositif (120).

6. Protection (100) selon l'une quelconque des revendications précédentes, les structures d'aile (110) étant pourvues d'un profilé de montage (220) de telle

sorte qu'un premier côté du profilé de montage (220) d'une première structure d'aile (110) peut être glissé dans un second côté du profilé de montage (220) d'une seconde structure d'aile (110).

7. Protection (100) selon la revendication 6, le profilé de montage (220) étant pourvu d'un système d'encliquetage de telle sorte que le un profilé de montage peut être encliqueté sur l'autre profilé de montage.

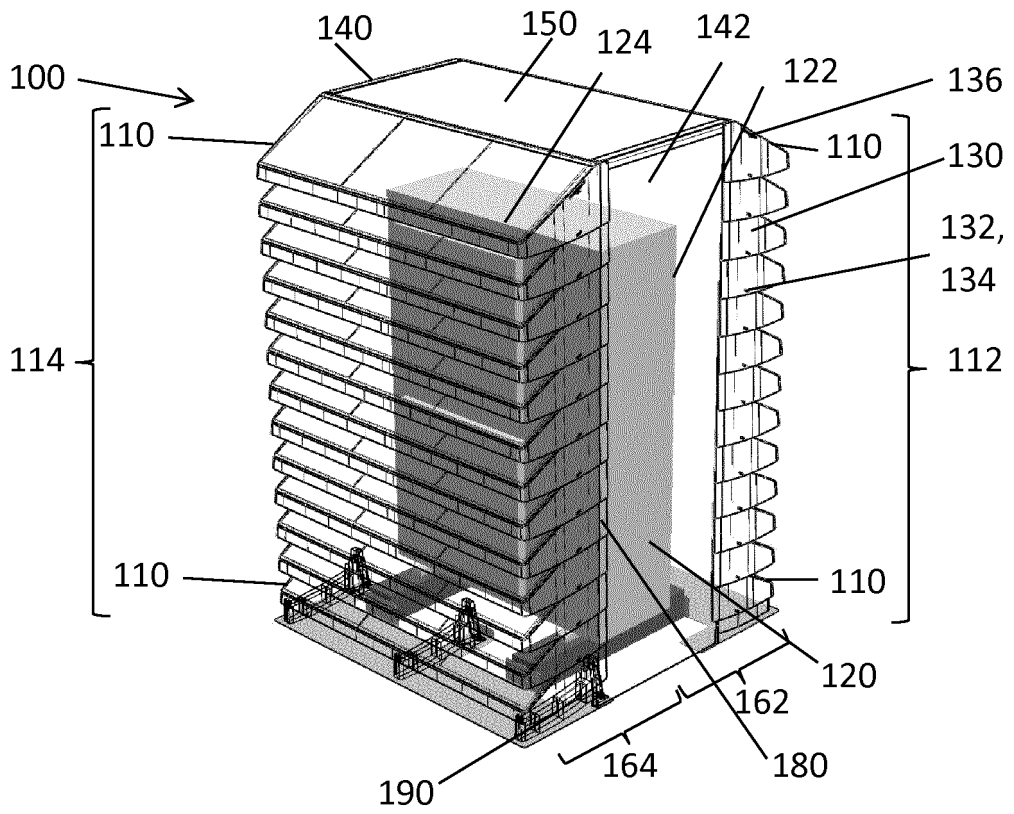

FIG. 1

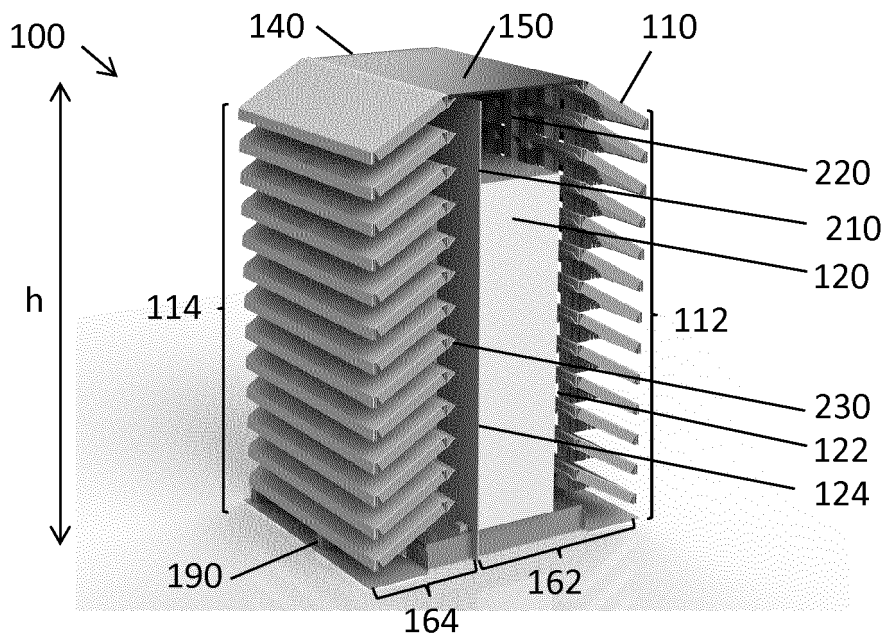

FIG. 2

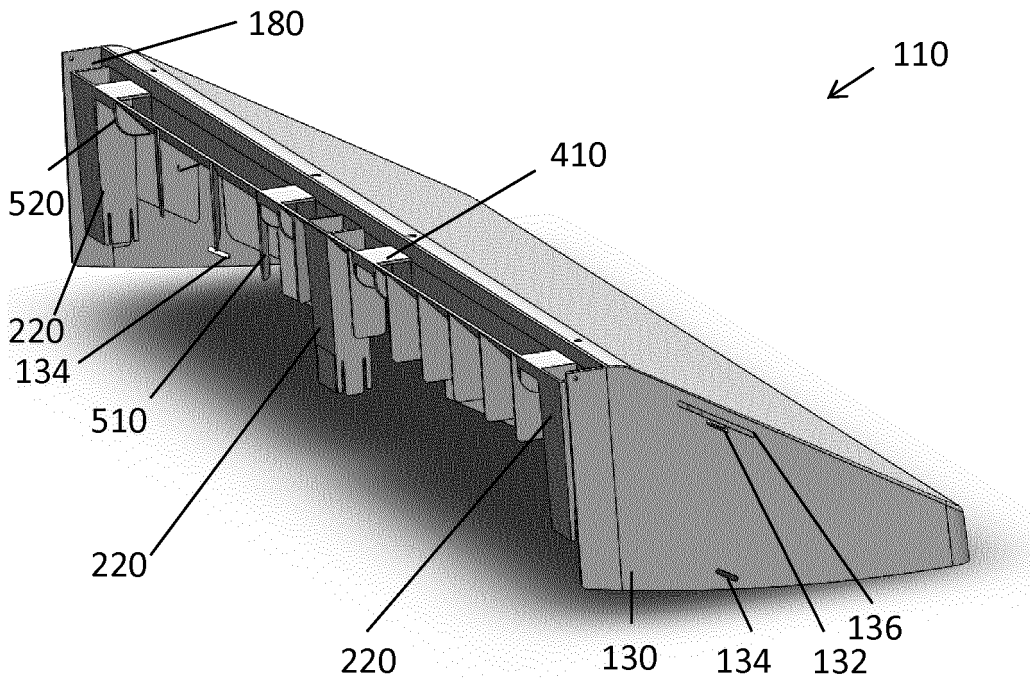

FIG. 5

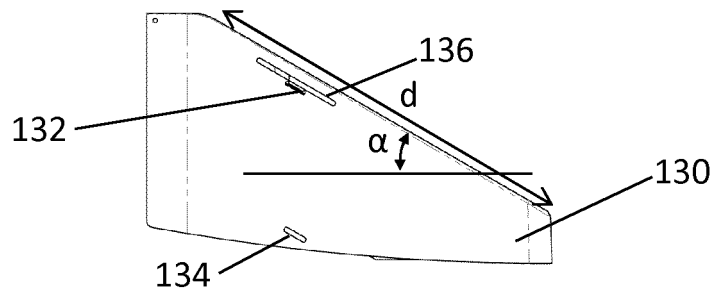

FIG. 6

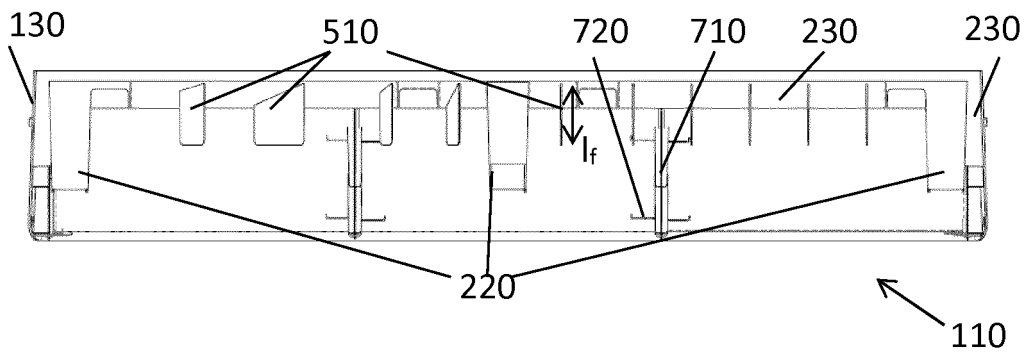

FIG. 7

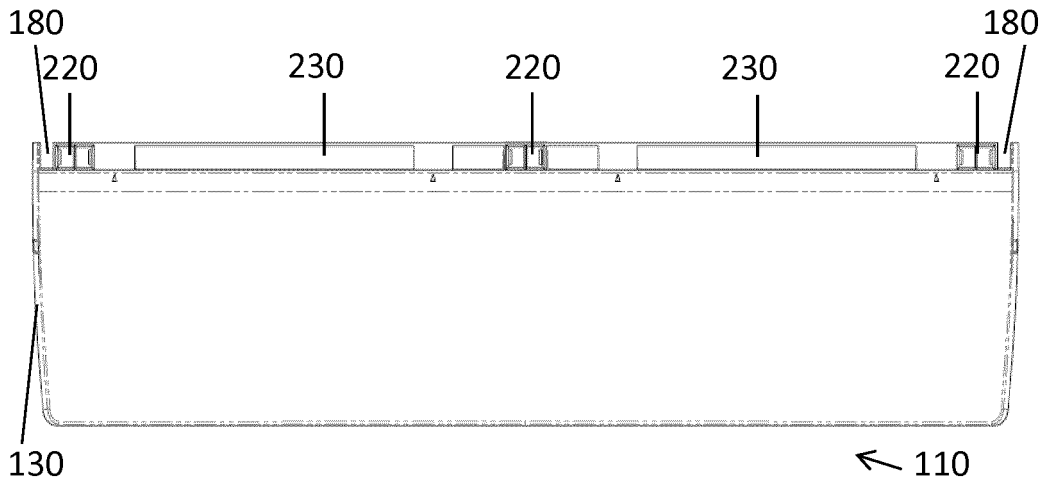

FIG. 8

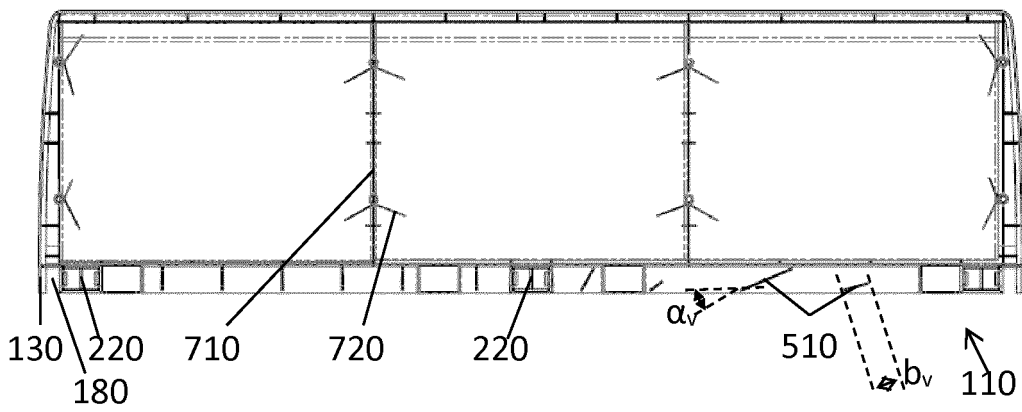

FIG. 9

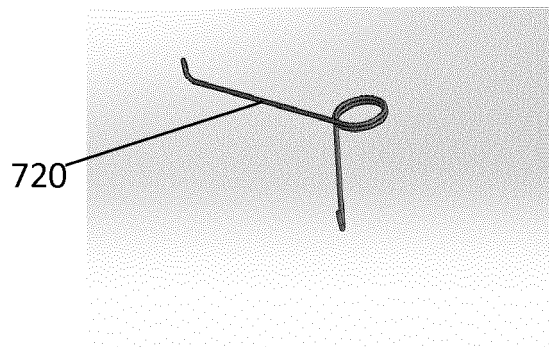

FIG. 10

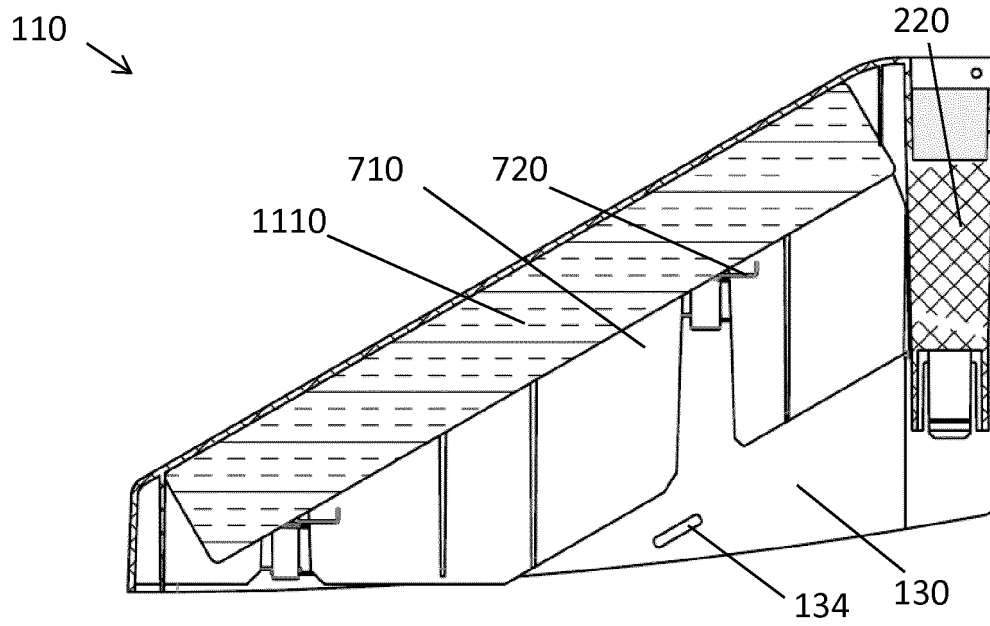

FIG. 11

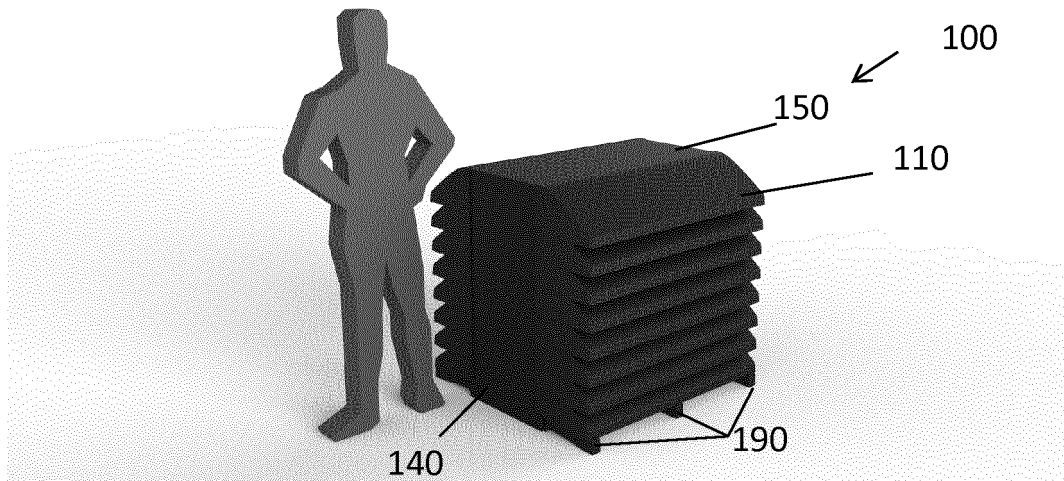

FIG. 12

REFERENCES CITED IN THE DESCRIPTION

This list of references cited by the applicant is for the reader's convenience only. It does not form part of the European patent document. Even though great care has been taken in compiling the references, errors or omissions cannot be excluded and the EPO disclaims all liability in this regard.

Patent documents cited in the description

- DE 1947152 A1 [0004]