

(19)



(11)

**EP 3 144 043 B1**

(12)

**EUROPEAN PATENT SPECIFICATION**

(45) Date of publication and mention of the grant of the patent:  
**31.10.2018 Bulletin 2018/44**

(51) Int Cl.:  
**A63J 25/00<sup>(2009.01)</sup> E04H 3/00<sup>(2006.01)</sup>**

(21) Application number: **15185387.6**

(22) Date of filing: **16.09.2015**

(54) **CINEMA ROOM FOR A MULTI-SCREEN CINEMA**

KINORAUM FÜR KINO MIT MEHREREN LEINWÄNDEN

SALLE DE CINÉMA POUR UN CINÉMA À ÉCRANS MULTIPLES

(84) Designated Contracting States:  
**AL AT BE BG CH CY CZ DE DK EE ES FI FR GB GR HR HU IE IS IT LI LT LU LV MC MK MT NL NO PL PT RO RS SE SI SK SM TR**

(43) Date of publication of application:  
**22.03.2017 Bulletin 2017/12**

(73) Proprietor: **Vallesviu, S.A.**  
**08290 Cerdanyola del Vallès (Barcelona) (ES)**

(72) Inventor: **SALLENT PUIGCERCOS, Pere**  
**08290 Cerdanyola del Vallès (BARCELONA) (ES)**

(74) Representative: **Mohammadian, Dario et al**  
**KUKATI**  
**Apartado de Correos 34031**  
**08080 Barcelona (ES)**

(56) References cited:  
**EP-A1- 0 987 383 WO-A2-99/56173**  
**CN-U- 203 160 750 US-A1- 2011 116 048**

**EP 3 144 043 B1**

Note: Within nine months of the publication of the mention of the grant of the European patent in the European Patent Bulletin, any person may give notice to the European Patent Office of opposition to that patent, in accordance with the Implementing Regulations. Notice of opposition shall not be deemed to have been filed until the opposition fee has been paid. (Art. 99(1) European Patent Convention).

## Description

### Subject of the invention

[0001] The object of this invention is a cinema room for a multi-screen cinema, each cinema room having a film projector, a projection screen and tiers of seats or stands with multiple rows of seats arranged to different heights.

[0002] The arrangement of the invention has peculiarities in its construction concerning the location of the film projector and the arrangement of the screen, providing multiple advantages concerning the management of the space intended for a multi-screen cinema, improving the quality of the projection by minimizing the deformation of the image projected on the screen, providing a better utilization of the projector light and maintaining the format of the projection in which the movie has been created, as well as obtaining the same horizontal vision angle for all of the seats, independently of the position of the seats in the room and independently of the dimensions of the room, improving the visualization of the movie by the public.

### State of the art

[0003] Multi-screen cinemas are currently known, having a flat screen or a variable curvature screen vertically arranged, on which frontal screen images are projected by means of film projectors located behind the projecting cinema room, higher than the tiers of seats. One such example is given in publication EP-A-0987383 referring to a movie theatre construction comprising a floor on which seats are installed and a projector oriented towards a screen mounted at a distance in height of said floor.

[0004] This arrangement of the film projectors brings about various problems among which the following may be cited:

the utilization of a part of the space aimed at the cinema room for building behind the room the projection cabins and a corridor for its access;

a limited utilization of the light of the projection and visual deformation of the projected image on the screen due to the high location of the projector in respect to the screen and to the difference in the horizontal angle visualization in respect to the viewers, in function of their location within the cinema room;

in case of screens of large dimensions, the lack of capacity to offer sufficient luminosity forces frequently to the use of a simultaneous projection with two projectors in each of the cinema rooms, with the assistance of mirrors or prisms which generate eventual convergence problems of the images on the screen.

[0005] The difference in the visualization angle and

comfort for the viewer between the first and the last rows of the cinema room is well known by the users, who avoid the occupation of the firsts rows or lower rows of seats in which they must adopt an uncomfortable position, having at the same time a worse vision of the images; specially in small or medium sized cinema rooms.

[0006] While it is true that projection rooms exist with characteristics oriented to obtain especial effects, as the known "OMNIMAX" cinema rooms, which use a screen with a surface similar to a an spherical quadrant; the inventor does not know the existence of prior art embodiments applicable to multi-screen cinemas having an arrangement similar to the present invention and solving satisfactorily the above related problems.

### Disclosure of the invention

[0007] The invention provides an arrangement for a cinema room according to claim 1.

[0008] The arrangement for a cinema room for a multi-screen cinema which is the object of the invention, having in each cinema room a projection screen, a film projector and a tiers of seats, has features aimed at solving the above problems of the presently known cinema rooms for multi-screen cinemas.

[0009] For this purpose and according to the invention, a feature of the present arrangement for cinema rooms for a multi-screen cinema consists in that each of the projection rooms has a projection screen with a surface which adopts the form of a cylindrical sector with constant curvature, being said projection screen tilted towards the tiers of seats, forming said screen an angle with the vertical comprised between 50° and 100°, preferably 70°.

[0010] With the inclination of the screen and its configuration in the form of a cylindrical sector, an immersion sensation is obtained by the viewers in respect to the scenes projected on the screen as well as a better aspect of the projections.

[0011] Another feature of the invention consists in the arrangement of the film projector inside of each cinema room, integrated in an intermediate area of the tiers of seats, and oriented towards the centre of the screen, forming with said screen an angle comprised between 80° and 100°, the objective being an angle of 90° with absolute perpendicularity in respect of the screen.

[0012] This peculiarity permits the integration in the cinema room of the spaces usually located behind the room and aimed at containing the projection cabins, so that a better utilization is obtained of the space for the parterre.

[0013] Said arrangement of the film projector, apart from preventing the deformation of the images, which occurs usually in the cinema rooms in which the film projector is arranged above the tiers of seats; permits a better utilization of the projector light given the perpendicularity of the projection in respect to the screen, being unnecessary, in case of large surface screens, the simultaneous use of two film projectors and intermediate ele-

ments for re-directing towards the screen and the convergence on the screen of the images coming from the two film projectors which operate simultaneously. Furthermore, with this arrangement of the film projector, the light cast on the screen returns to the central area of the tiers of seats, improving the luminosity of the projection.

**[0014]** With the arrangement of a unique film projector in the central or intermediate areas of each cinema room, it is possible to minimize the difference in vertical deformation among the different rows of seats, which together with the configuration of the screen in the form of a cylindrical sector, provides an optimized vision of the images by the viewers.

**[0015]** Further, the inclination of the screen towards the tiers of seats or parterre provides the same angle for horizontal vision from all the seats, independently of the dimensions of the cinema room.

**[0016]** Additionally, and with the end to optimise the comfort of the users, at least the first row or seats or lower row of seats has bed-like seats, in which the viewers can arrange themselves lying or seating with a larger inclination than in the rest of seats of the rows of seats located behind, improving the comfort of the viewers.

**[0017]** The above features as well as other features of the invention will be more easily understood from the detailed consideration of an example embodiment according to the annexed drawing.

### Description of the drawing

**[0018]** To complete the description of the invention and to facilitate the understanding of the features of the invention a set of drawings is annexed to this description in which, with an illustrative character but non to limit the scope of the invention, the following has been shown:

- Figure 1 shows a plant view of an example embodiment of a cinema room for a multi-screen cinema arranged according to the invention.
- Figure 2 shows an elevation view of a cross section of the cinema room of figure 1.
- Figure 3 shows a vertical projection of the screen for the cinema room corresponding to figures 1 and 2, showing the cross section of the cylindrical sector forming said screen, as well as the height and secant of the cylindrical sector shaped screen.

### Preferred embodiment of the invention

**[0019]** Figures 1 and 2 illustrate a cinema room for a multi-screen cinema according to the invention, having a film projector (1), a projection screen (2) and the tiers of seats (3) with multiple rows of seats (3a, 3b, ..., 3n).

**[0020]** As is to be seen from the annexed figures of drawings, the movie projection screen (2) has a surface in the form of a cylindrical sector, with constant curvature, being inclined towards the low frontal area as may be observed in figure 2, forming an angle (a) with a vertical

line comprised between 5° and 10°, preferably 7°.

**[0021]** Said screen (2) has format 1:1.86 which corresponds to a chip format used in digital projectors.

**[0022]** The movie projector (1) is integrated in an intermediate area of the tiers of seats (3), between the seats and directed towards the centre of the screen (2) forming with said screen (2) an angle comprised between 80° and 100°, preferably 90°; so that a high utilization of the light coming from the film projector (1) is obtained as well as an absolute maintenance of the projecting formats in which the film has been created.

**[0023]** As is to be observed in figures 1 and 2, the first row (3a) of the tiers of seats has bed-like seats, which objective is to permit the viewers using the same to arrange themselves lying or seated with a higher inclination than the rest of seats in the other rows of seats (3b, ..., 3n) improving the visualization of the screen.

**[0024]** As may be observed in figure 3, the cylindrical sector-like surface defined by the screen (2) has a height (F) as well as a secant (S) with a length ratio comprised between 1:15 and 1:20.

**[0025]** After the invention having been sufficiently described in its nature, including a preferred example of an embodiment of same, it is stated to all effects that the materials, shape, size and arrangement of the described elements may be modified, whenever the modifications do not mean an alteration of the essential characteristics of the invention, as claimed in the following set of claims.

### Claims

1. Arrangement for a cinema room for a multi-screen cinema, **characterized in that** each of the cinema rooms has a trapezoidal layout with a larger end where the screen (2) is arranged, a film projector (1), and tiers of seats (3) with multiple rows of seats (3a, 3b, ..., 3n) arranged to different step-wise heights; wherein the screen (2) has a surface in form of a cylindrical sector with a constant curvature, being inclined towards the stands forming an angle (a) with respect to a vertical line comprised between 5° and 10° and **in that** the film projector (1) is integrated in an intermediate area of the tiers of seats (3), oriented towards the centre of the screen (2), forming with the screen (2) an angle (b) comprised between 80° and 100°.
2. Arrangement, according to claim 1, wherein the surface in form of a cylindrical sector of the screen (2) has a height (F) and a secant (S) with a length ratio comprised between 1:15 and 1:20.
3. Arrangement, according to claim 2, wherein the screen has a format of 1:1.86.
4. Arrangement, according to claim 1, wherein the angle (a) of the screen (2) with respect to a vertical line

is of 7°.

5. Arrangement, according to claim 1, wherein the angle (b) formed by the film projector (1) in respect to the screen (2) is of 90°.
6. Arrangement, according to any of the previous claims, wherein at least the first row of seats (3a) has bed-like seats in which the viewers can arrange themselves lying or seated with a higher inclination than in the rows of seats located behind (3b, ..., 3n).

#### Patentansprüche

1. Anordnung für einen Kinosaal für ein Kino mit mehreren Leinwänden, **dadurch gekennzeichnet, dass** jeder der Kinosäle einen trapezförmigen Grundriss mit einem größeren Ende, an dem die Leinwand (2) angeordnet ist, einen Filmprojektor (1) und Sitzstufen (3) mit mehreren Sitzreihen (3a, 3b, ..., 3n) aufweist, die in unterschiedlichen Stufenhöhen angeordnet sind; wobei die Leinwand (2) eine Oberfläche in Form eines zylindrischen Sektors mit einer konstanten Krümmung aufweist, die zu den Ständern hin geneigt ist und mit einer vertikalen Linie einen Winkel (a) zwischen 5° und 10° bildet, und dass der Filmprojektor (1) in einen Zwischenbereich der Sitzstufen (3) integriert ist, der auf die Mitte der Leinwand (2) ausgerichtet ist und mit der Leinwand (2) einen Winkel (b) zwischen 80° und 100° bildet.
2. Anordnung nach Anspruch 1, wobei die Oberfläche in Form eines zylindrischen Sektors der Leinwand (2) eine Höhe (F) und eine Sekante (S) mit einem Längenverhältnis zwischen 1:15 und 1:20 aufweist.
3. Anordnung nach Anspruch 2, wobei die Leinwand ein Format 1:1,86 aufweist.
4. Anordnung nach Anspruch 1, wobei der Winkel (a) der Leinwand (2) mit einer vertikalen Linie 7° beträgt.
5. Anordnung nach Anspruch 1, wobei der Winkel (b), den der Filmprojektor (1) mit der Leinwand (2) bildet, 90° beträgt.
6. Anordnung nach einem der vorstehenden Ansprüche, wobei zumindest die erste Sitzreihe (3a) bettartige Sitze aufweist, in denen sich die Zuschauer liegend oder mit einer höheren Neigung als in den dahinter befindlichen Sitzreihen (3b, ..., 3n) sitzend anordnen können.

néma à écrans multiples, **caractérisé en ce que** chacune des salles de cinéma a une disposition trapézoïdale avec une extrémité plus grande où l'écran (2) est disposé, un projecteur de film (1) et des niveaux de sièges (3) avec plusieurs rangées de sièges (3a, 3b, ..., 3n) disposées à différentes hauteurs par paliers ; dans lequel l'écran (2) a une surface en forme de secteur cylindrique avec une courbure constante, étant incliné vers les supports formant un angle (a) par rapport à une ligne verticale comprise entre 5° et 10° et dans lequel le projecteur de film (1) est intégré dans une zone intermédiaire des niveaux de sièges (3), orientée vers le centre de l'écran (2), formant avec l'écran (2) un angle (b) compris entre 80° et 100°.

2. Agencement, selon la revendication 1, dans lequel la surface en forme d'un secteur cylindrique de l'écran (2) a une hauteur (F) et une sécante (S) avec un rapport de longueur compris entre 1:15 et 1:20.
3. Arrangement, selon la revendication 2, dans lequel l'écran a un format de 1:1,86.
4. Agencement, selon la revendication 1, dans lequel l'angle (a) de l'écran (2) par rapport à une ligne verticale est de 7°.
5. Agencement, selon la revendication 1, dans lequel l'angle (b) formé par le projecteur de film (1) par rapport à l'écran (2) est de 90°.
6. Agencement, selon l'une quelconque des revendications précédentes, dans lequel au moins la première rangée de sièges (3a) a des sièges en forme de lit dans lesquels les spectateurs peuvent s'allonger ou s'asseoir avec une inclinaison plus élevée que dans les rangées de sièges situées derrière (3b, ..., 3n).

#### Revendications

1. Agencement pour une salle de cinéma pour un ci-

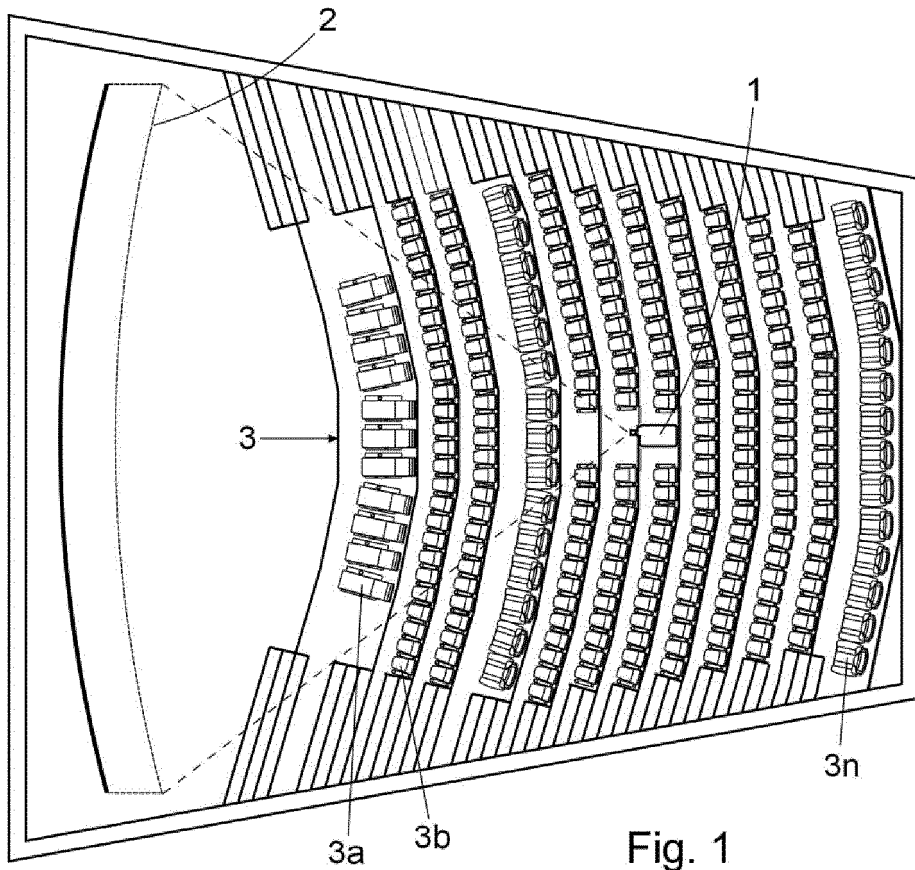

Fig. 1

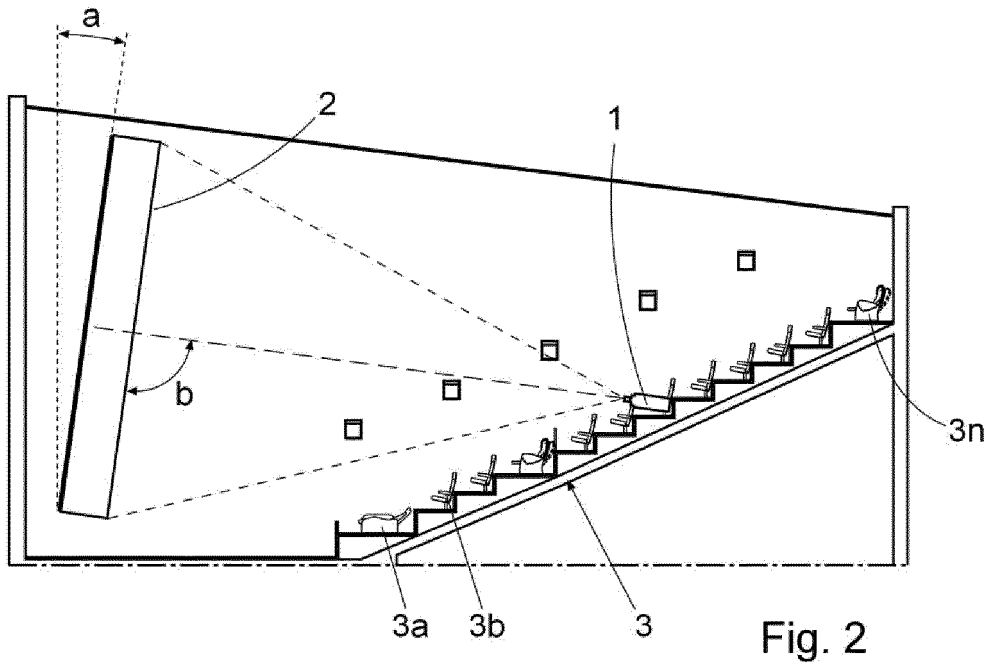

Fig. 2

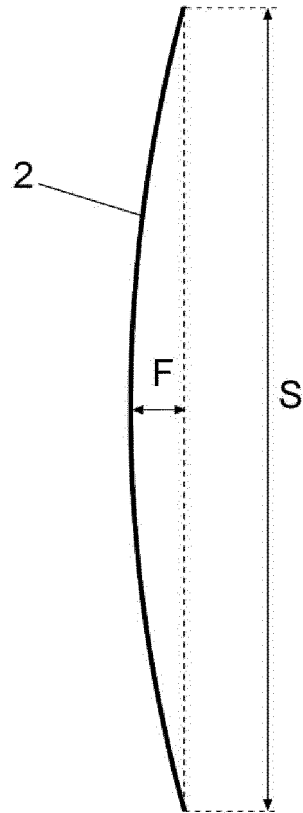

Fig. 3

**REFERENCES CITED IN THE DESCRIPTION**

*This list of references cited by the applicant is for the reader's convenience only. It does not form part of the European patent document. Even though great care has been taken in compiling the references, errors or omissions cannot be excluded and the EPO disclaims all liability in this regard.*

**Patent documents cited in the description**

- EP 0987383 A [0003]