



(11) **EP 3 207 809 A1**

(12) **EUROPEAN PATENT APPLICATION**
published in accordance with Art. 153(4) EPC

(43) Date of publication:
23.08.2017 Bulletin 2017/34

(51) Int Cl.:
A24B 15/26 (2006.01)

(21) Application number: **15852051.0**

(86) International application number:
PCT/JP2015/079053

(22) Date of filing: **14.10.2015**

(87) International publication number:
WO 2016/063775 (28.04.2016 Gazette 2016/17)

(84) Designated Contracting States:
AL AT BE BG CH CY CZ DE DK EE ES FI FR GB GR HR HU IE IS IT LI LT LU LV MC MK MT NL NO PL PT RO RS SE SI SK SM TR
Designated Extension States:
BA ME
Designated Validation States:
MA

- **AKIYAMA, Takeshi**
Tokyo 130-8603 (JP)
- **OSUGA, Shinya**
Tokyo 130-8603 (JP)
- **TAKEUCHI, Manabu**
Tokyo 130-8603 (JP)
- **YAMADA, Manabu**
Tokyo 130-8603 (JP)

(30) Priority: **24.10.2014 PCT/JP2014/078410**

(74) Representative: **Isarpotent**
Patent- und Rechtsanwälte Behnisch Barth
Charles
Hassa Peckmann & Partner mbB
Friedrichstrasse 31
80801 München (DE)

(71) Applicant: **Japan Tobacco, Inc.**
Tokyo 105-8422 (JP)

(72) Inventors:
• **FUJISAWA, Yoshinori**
Tokyo 130-8603 (JP)

(54) **METHOD FOR PRODUCING CIGARETTE INGREDIENT**

(57) A producing method of a tobacco raw material containing a flavor constituent, comprises: a step A for heating a tobacco raw material in a closed space which is treated with alkali and for taking a flavor constituent released in the gas phase from the tobacco raw material to an outside of the closed space; a step B for allowing a first solvent to capture the flavor constituent by bringing the flavor constituent released in the gas phase in the step A into contact with the first solvent which is a liquid substance at normal temperature on the outside of the closed space; a step C for supplying a second solvent to the tobacco raw material in the closed space after the step A and for taking a normal component which is released as the liquid phase from the tobacco raw material to the second solvent, together with the second solvent to the outside of the closed space; and after the steps B and C, the step D for adding the first solvent capturing the flavor constituent in the step B to the tobacco raw material from which the flavor constituent is released to the outside of the closed space in the step A.

FIG. 4

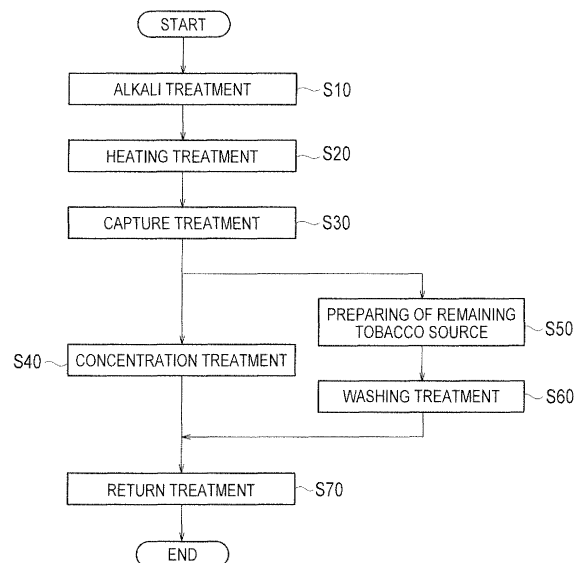

EP 3 207 809 A1

Description

TECHNICAL FIELD

5 **[0001]** The present invention relates to a producing method of a tobacco raw material containing a flavor constituent.

BACKGROUND ART

10 **[0002]** As a technique to allow a flavor source to contain a flavor constituent (e.g. alkaloid including a nicotine component), a technique utilizing a tobacco raw material itself as a flavor source, and a technique in which a flavor constituent is extracted from a tobacco raw material and supported on a base material for a flavor source have been conventionally known.

15 **[0003]** In the above-described techniques, there is a possibility that impurity components contained in a tobacco raw material have a bad effect on a smoking flavor and the like, and thus it is desired that only the impurity components be selectively separated/reduced from the tobacco raw material. In the existing techniques, however, a complicated process is required, and thus there has been a problem in that simple and low-cost separation and reduction are difficult.

CITATION LIST

20 PATENT LITERATURE

[0004]

25 Patent Literature 1: US 4,215,706
 Patent Literature 2: JP 2009-502160 A
 Patent Literature 3: US 5,235,992

SUMMARY

30 **[0005]** A first feature is summarized as a producing method of a tobacco raw material containing a flavor constituent, comprising: a step A for heating a tobacco raw material in a closed space which is treated with alkali and for taking a flavor constituent released in the gas phase from the tobacco raw material to an outside of the closed space; a step B for allowing a first solvent to capture the flavor constituent by bringing the flavor constituent released in the gas phase in the step A into contact with the first solvent which is a liquid substance at normal temperature on the outside of the closed space; a step C for supplying a second solvent to the tobacco raw material in the closed space after the step A and for taking a normal component which is released as the liquid phase from the tobacco raw material to the second solvent, together with the second solvent to the outside of the closed space; and after the step B and the step C, the step D for adding the first solvent capturing the flavor constituent in the step B to the tobacco raw material from which the flavor constituent is released to the outside of the closed space in the step A.

40 **[0006]** A second feature is summarized as the production method according to the first feature, wherein the step D is, in the closed space after the steps B and C1, a step C1 for adding the first solvent capturing the flavor constituent in the step B1 to the tobacco raw material from which the flavor constituent is released to the outside of the closed space in the step A1 in the closed space.

45 **[0007]** A third feature is summarized as the production method according to the first feature or the second feature, wherein the step C is repeated at least twice or more before the step D.

[0008] A fourth feature is summarized as the production method according to the third feature, wherein when n is an integer of 1 or more, a solvent A is used as the second solvent in the n-th step C, and a solvent B different from the solvent A is used as the second solvent in the n + 1-th step C.

50 **[0009]** A fifth feature is summarized as the production method according to the third feature or the fourth feature, wherein the step C is repeated at least two or more times using the second solvents having respectively different temperatures.

[0010] A sixth feature is summarized as the production method according to the fifth feature, wherein the step C includes a step of bubbling while adding CO₂ gas to the second solvent having a lowest temperature among different temperatures.

55 **[0011]** A seventh feature is summarized as the production method according to the fifth feature or sixth feature, wherein the step C includes a step of bubbling while adding CO₂ gas to the second solvent having a temperature of 20°C or less.

[0012] An eighth feature is summarized as the production method according to any one of the first feature to the seventh feature, wherein the step C includes: taking the normal component out of the closed space by using water

having a first temperature as the second solvent; and taking the normal component out of the closed space by bubbling while adding CO₂ gas to a water having a second temperature as a second solvent, the second temperature being lower than the first temperature.

[0013] A ninth feature is summarized as the production method according to any one of the first feature to the eighth feature, wherein the step A comprises a step in which the tobacco source is subjected to a water addition treatment.

[0014] A tenth feature is summarized as the production method according to the ninth feature, wherein in the step A, an amount of water in the tobacco source before heating the tobacco source becomes 30 wt% or more by the water addition treatment.

[0015] A eleventh feature is summarized as the production method according to any one of the first feature to the tenth feature, wherein the step A comprises a step for adding a non-aqueous solvent to the tobacco raw material.

[0016] A twelfth feature is summarized as the production method according to the eleventh feature, wherein the amount of the non-aqueous solvent is 10 wt% or more with respect to the tobacco raw material.

[0017] A thirteenth feature is summarized as the production method according to the eleventh feature or twelfth feature, the step A comprises a step for adding the non-aqueous solvent and water to the tobacco raw material.

[0018] A fourteenth feature is summarized as the production method according to any one of the first feature to the thirteenth feature, wherein a temperature of the first solvent is 10°C or more and 40°C or less.

[0019] It is preferred that the volume of the closed space recited in the first feature not be extremely different from the volume of a tobacco raw material from the viewpoint of reducing the loss of a tobacco raw material by reducing the inner surface of the closed space. It is also preferred that the volume of the closed space recited in the first feature not be extremely different from the volume of a tobacco raw material from the viewpoint of efficient washing. It is preferred that the shape of the closed space recited in the first feature not contain an extremely long part and the like from the viewpoint of reducing the loss of a tobacco raw material by reducing the inner surface of the closed space. It is also preferred that the shape of the closed space recited in the first feature not contain an extremely long part and the like from the viewpoint of efficient washing. It is preferred that the volume of the closed space be for example 3 times or more and 50 times or less the volume of a tobacco raw material. About the shape of the closed space, it is also preferred that when the lengths of the longest parts in the X direction, the Y direction and the Z direction which are directions intersecting each other at 90 degrees in the closed space are considered as X, Y and Z respectively and two values between X, Y and Z which differ most are used as L and S (S is a value smaller than L), L be 10 times or less higher than S. As long as the volume and shape of the closed space are as described above, the loss of a tobacco raw material can be reduced, and further a tobacco raw material (residue) can be sufficiently washed in Step C recited in the first feature using a moderate amount of solvent while moderately stirring the tobacco raw material.

[0020] It should be noted that when the inner surface of the closed space is reduced or an extremely long part and the like are not contained in the shape of the closed space, the contact area of a tobacco raw material with the inner surface of the closed space decreases, and a tobacco raw material adhering to the inner surface of the closed space also decreases, thereby reducing the loss of the tobacco raw material.

[0021] It should be noted that all above-described wt% is percent by weight in the dry state.

BRIEF DESCRIPTION OF DRAWINGS

[0022]

Fig. 1 is a diagram illustrating an example of the extraction device in the first embodiment.

Fig. 2 is a diagram illustrating an example of the extraction device in the first embodiment.

Fig. 3 is a diagram illustrating an example of the application of a flavor constituent.

Fig. 4 is a flow diagram showing the production method in the first embodiment.

Fig. 5 is a diagram illustrating the first experiment.

Fig. 6 is a diagram illustrating the first experiment.

Fig. 7 is a diagram illustrating the first experiment.

Fig. 8 is a diagram illustrating the second experiment.

Fig. 9 is a diagram illustrating the second experiment.

Fig. 10 is a diagram illustrating the third experiment.

Fig. 11 is a diagram illustrating the third experiment.

Fig. 12 is a diagram illustrating the fourth experiment.

Fig. 13 is a diagram illustrating the fourth experiment.

DESCRIPTION OF EMBODIMENTS

[0023] Next, an embodiment will be described. Note that, the same or similar portions are denoted with the same or

similar reference signs in the descriptions of the drawings below. Note that, the drawings are schematic and a ratio of each size is different from a real one.

[0024] Therefore, specific sizes and the like should be judged in consideration of the following descriptions. Needless to say, portions of which relationship and ratios of mutual sizes are different between the mutual drawings, are included.

[First embodiment]

(Production device)

[0025] The production device according to the first embodiment will be described below. Fig. 1 and Fig. 2 are diagrams showing an example of the production device according to the first embodiment.

[0026] First, an example of a treatment device 10 will be described with reference to Fig. 1. The treatment device 10 has a container 11 and a spray 12.

[0027] A tobacco raw material 50 is put in the container 11. The container 11 is constituted of for example members with heat resistance and pressure resistance (e.g. SUS; Steel Used Stainless). It is preferred that the container 11 constitute a closed space. The "closed space" is a space to prevent the contamination of the space by solid foreign substances in normal handling (e.g. treatment action, transportation, storage, etc.) and inhibit the movement of a flavor constituent (e.g. a nicotine component) contained in the tobacco raw material 50 to the outside of the space. Therefore, a tobacco raw material is maintained in a sanitary condition and it is not required to transfer the tobacco raw material, and therefore the loss of the tobacco raw material decreases. It should be noted however that the treatments for intentionally taking a predetermined component to the outside of the space like for example Step S30 (capture treatment) and Step S60 (washing) described below are not contrary to the definition of the above-described "closed space".

[0028] It should be noted that a nicotine component is an example of a flavor constituent contributing to a tobacco smoking flavor and is used as an index of the flavor constituent in the embodiment.

[0029] The spray 12 provides an alkaline substance for the tobacco raw material 50. It is preferred that a basic substance such as an aqueous solution of potassium carbonate, for example, be used as an alkaline substance.

[0030] It is preferred that the spray 12 provide an alkaline substance for the tobacco raw material 50 until the pH of the tobacco raw material 50 becomes 8.0 or more. It is further preferred that the spray 12 provide an alkaline substance for the tobacco raw material 50 until the pH of the tobacco raw material 50 becomes in a range from 8.9 to 9.7. In order to efficiently release a flavor constituent in the gas phase from the tobacco raw material 50, the amount of water in the tobacco raw material 50 after spraying of an alkaline substance is preferably 10 wt% and further preferably 30 wt% or more. The upper limit of the amount of water in the tobacco raw material 50 is not particularly limited, and is for example preferably 50 wt% or less in order to efficiently heat the tobacco raw material 50.

[0031] It is preferred that the initial amount of flavor constituent (herein, a nicotine component) contained in the tobacco raw material 50 be 2.0 wt% or more in the case where the gross weight of the tobacco raw material 50 in the dry state is 100 wt%. It is further preferred that the initial amount of flavor constituent (herein, a nicotine component) contained be 4.0 wt% or more.

[0032] As the tobacco raw material 50, for example, Nicotiana raw materials such as Nicotiana. tabacum and Nicotiana. rustica can be used. As Nicotiana tabacum, for example, a variety such as Burley type or flue cured type can be used. As the tobacco raw material 50, a tobacco raw material of a type other than Burley type and flue cured type may be also used.

[0033] The tobacco raw material 50 may be constituted of a cut or powder tobacco raw material. In such case, the diameter of a cut or powder substance is preferably 0.5 mm to 1.18 mm.

[0034] Second, an example of a capturing device 20 will be described with reference to Fig. 2. The capturing device 20 has a container 21, a pipe 22, a release section 23 and a pipe 24.

[0035] A capture solvent 70 (i.e. a first solvent) is put in the container 21. The container 21 is constituted of a member that has resistance to the capture solvent, volatile flavor constituent and volatile impurity components (for example a glass or a stainless steel (SUS)). It is preferred that the container 21 constitute of an airtight space to a degree in which the movement of air to the outside of the space can be inhibited.

[0036] The temperature of the capture solvent 70 is for example normal temperature. The lower limit of normal temperature is for example a temperature at which the capture solvent 70 is not solidified, preferably 10°C. The upper limit of normal temperature is for example 40°C or less. By setting the temperature of the capture solvent 70 to 10°C or more and 40°C or less, as the vaporization of a flavor constituent from the capture solvent 70 capturing the flavor constituent (hereafter, called as "capturing solution") is suppressed, volatile impurity components such as ammonium ion and pyridine can be efficiently removed from the capture solution. As the capture solvent 70, for example, glycerin, water or ethanol can be used. In order to prevent the revaporization of a flavor constituent captured by the capture solvent 70, any acid such as malic acid or citric acid may be added to the capture solvent 70. In order to raise capture efficiency for a flavor constituent, a solvent such as an aqueous solution of citric acid may be added to the capture solvent 70. That is, the

capture solvent 70 may be constituted of several types of solvents. In order to raise capture efficiency for a flavor constituent, the initial pH of the capture solvent 70 is preferably lower than the pH of the tobacco raw material 50 after an alkali treatment. In order to set the temperature of the capturing solvent 70 to 10°C or more and 40°C or less, the temperature of the container 21 may be cooled to a temperature lower than normal temperature (for example, 5°C).

[0037] The pipe 22 takes a release component 61, which is released in the gas phase from the tobacco raw material 50 by heating the tobacco raw material 50, to the capture solvent 70. The release component 61 contains at least a nicotine component which is an index of a flavor constituent. Since the tobacco raw material 50 has treated with alkali, the release component 61 contains ammonium ion in some cases depending on time elapsing from the beginning of the capture step of a flavor constituent (treatment time). The release component 61 contains TSNA in some cases depending on time elapsing from the beginning of the capture step (treatment time).

[0038] A release section 23 is provided on the tip of the pipe 22 and immersed in the capture solvent 70. The release section 23 has a plurality of openings 23A. The release component 61 taken by the pipe 22 is released in the capture solvent 70 from a plurality of openings 23A as a foam-like release component 62.

[0039] The pipe 24 takes a residual component 63 which has not been captured by the capture solvent 70 to the outside of the container 21.

[0040] Since the release component 62 is a component which is released in the gas phase by heating the tobacco raw material 50, there is a possibility that the temperature of the capture solvent 70 is raised by the release component 62. Therefore, the capturing device 20 may have a function for cooling the capture solvent 70 to maintain the temperature of the capture solvent 70 to normal temperature.

[0041] The capturing device 20 may have a raschig ring to increase the contact area of the release component 62 with the capture solvent 70.

(Application example)

[0042] An example of the application of a flavor constituent extracted from the tobacco raw material 50 will be described below. Fig. 3 is a diagram illustrating an example of the application of a flavor constituent. For example, a flavor constituent is provided for a constituent of a favorite item (e.g. a flavor source for a flavor inhaler).

[0043] As shown in Fig. 3, a flavor inhaler 100 has a holder 110, a carbon heat source 120, a flavor source 130 and a filter 140.

[0044] The holder 110 is for example a paper pipe with a tubular shape. The carbon heat source 120 generates heat to heat the flavor source 130. The flavor source 130 is a substance to generate a flavor and is an example of a base material for a flavor source for which a flavor constituent is provided. The filter 140 inhibits the introduction of impurity substances to the mouthpiece side.

[0045] The flavor inhaler 100 is described herein as an example of the application of a flavor constituent, but the embodiments are not limited thereto. A flavor constituent may be applied to other inhalers, for example, an aerosol source for electronic cigarettes (what is called E-liquid). In addition, a flavor constituent may be provided for base materials for a flavor source such as gum, tablets, films and candy.

(Producing method)

[0046] The method for producing a tobacco raw material involved in the first embodiment will be described below. Fig. 4 is a flow diagram showing the production method involved in the first embodiment.

[0047] As shown in Fig. 4, an alkaline substance is provided for the tobacco raw material 50 using the above-described treatment device 10 in Step S10. As the alkaline substance, for example, a basic substance such as an aqueous solution of potassium carbonate can be used.

[0048] It is preferred that the initial amount of flavor constituent (herein, a nicotine component) contained in the tobacco raw material 50 be 2.0 wt% or more in the case where the gross weight of the tobacco raw material 50 in the dry state is 100 wt%. It is further preferred that the initial amount of flavor constituent (herein, a nicotine component) contained be 4.0 wt% or more.

[0049] The pH of the tobacco raw material 50 after an alkali treatment is preferably 8.0 or more as described above. Further preferably, the pH of the tobacco raw material 50 after an alkali treatment is preferably in a range from 8.9 to 9.7.

[0050] In Step S20 (i.e. step A), the tobacco raw material 50 which has been treated with alkali is heated in a closed space (in the above-described container 11 in the embodiment) to take a flavor constituent which is released in the gas phase from the tobacco raw material 50 to the outside of the closed space. In the heating treatment, for example, the tobacco raw material 50 can be heated with the container 11 with the tobacco raw material 50 put in the container 11 in the treatment device 10. In such case, it is needless to say that the pipe 22 in the capturing device 20 is attached to the container 11.

[0051] The heating temperature of the tobacco raw material 50 is in a range from 80°C or more to less than 150°C.

By setting the heating temperature of the tobacco raw material 50 to 80°C or more, a time when a flavor constituent is sufficiently released from the tobacco raw material 50 can be earlier. By setting the heating temperature of the tobacco raw material 50 to less than 150°C, meanwhile, a time when TSNA is released from the tobacco raw material 50 can be delayed.

5 **[0052]** The tobacco raw material 50 may be subjected to a water addition treatment before heating the tobacco raw material 50. Such water addition treatment may be carried out in Step S10 or may be carried out before heating the tobacco raw material 50 in Step S20. Alternatively, the water addition treatment may be carried out in the process of heating the tobacco raw material 50 in Step S20 to supplement water which decreases by heating the tobacco raw material 50 in Step S20. In such case, the water addition treatment may be intermittently carried out at least once or more. Alternatively, the water addition treatment may be successively carried out over a predetermined period. The amount of water in the tobacco raw material 50 before heating the tobacco raw material 50 is preferably 30 wt% or more. The upper limit of the amount of water in the tobacco raw material 50 is not particularly limited, and for example preferably 50 wt% or less to efficiently heat the tobacco raw material 50.

10 **[0053]** In addition, Step S20 (heating treatment) preferably comprises the step for adding a non-aqueous solvent to the tobacco raw material 50. The amount of non-aqueous solvent is preferably 10 wt% or more and 50 wt% or less with respect to the tobacco raw material 50. Therefore, impurity substances soluble in such non-aqueous solvent under the heating condition move from the tobacco raw material 50 to the non-aqueous solvent through the liquid phase, and thus the impurity substances can be efficiently removed in Step S60 (washing treatment) described below. The non-aqueous solvent may be a solvent other than water. Specific examples of non-aqueous solvents include glycerin, propylene glycol, ethanol, alcohol, acetonitrile, hexane and the like. In the step for adding a non-aqueous solvent to the tobacco raw material 50, the non-aqueous solvent and further water may be added to the tobacco raw material 50.

15 **[0054]** The time for adding a non-aqueous solvent to the tobacco raw material 50 may be a time before Step S20 (heating treatment) is completed. For example, the time for adding a non-aqueous solvent to the tobacco raw material 50 may be a time between Step S10 (alkali treatment) and Step S20 (heating treatment). Alternatively, the time for adding a non-aqueous solvent to the tobacco raw material 50 may be a time in the process of Step S20 (heating treatment). In addition, the non-aqueous solvent is preferably a solvent which is not substantially vaporized at the heating temperature in Step S20 (heating treatment). Therefore, such non-aqueous solvent and impurity substances dissolved in the non-aqueous solvent can be inhibited from contaminating a capture solvent in Step S30 described below.

20 **[0055]** When the tobacco raw material 50 is heated in Step S20, the tobacco raw material 50 may be subjected to a water addition treatment. The amount of water in the tobacco raw material 50 is preferably maintained to 10% or more and 50% or less by the water addition treatment. In Step 20, water may be successively added to the tobacco raw material 50. The amount of water added is preferably adjusted so that the amount of water in the tobacco raw material 50 is 10% or more and 50% or less. Further, the above-described non-aqueous solvent may be added to the tobacco raw material 50 during the water addition treatment.

25 **[0056]** It is also preferred that the tobacco raw material 50 be subjected to an aeration treatment in Step S20. Therefore, the amount of flavor constituent contained in the release component 61 which is released in the gas phase from the alkali-treated tobacco raw material 50 can be increased. In the aeration treatment, for example, saturated water vapor at 80°C is brought into contact with the tobacco raw material 50. The aeration time in the aeration treatment varies depending on a device for treating the tobacco raw material 50 and the amount of tobacco raw material 50, and thus cannot be necessarily specified, and for example, the aeration time is within 300 minutes when the tobacco raw material 50 is 500 g. The gross aeration volume in the aeration treatment also varies depending on a device for treating the tobacco raw material 50 and the amount of tobacco raw material 50, and thus cannot be necessarily specified, and for example, the volume is about 10 L/g when the tobacco raw material 50 is 500 g.

30 **[0057]** Air used in the aeration treatment is not necessarily saturated water vapor. The amount of water in air used in the aeration treatment may be adjusted so that water contained in the tobacco raw material 50 to which the heating treatment and the aeration treatment have been applied is for example less than 50% without particularly requiring the humidification of the tobacco raw material 50. The gas used in the aeration treatment is not limited to air and may be inert gases such as nitrogen and argon.

35 **[0058]** In Step S30 (i.e. step B2), a flavor constituent which has been released in the gas phase in Step S20 is brought into contact with the capture solvent 70 (a first solvent) which is a liquid substance at normal temperature on the outside of the closed space (the outside of the above-described container 11 in the embodiment), that is, in the capturing device 20 in the embodiment to allow the capture solvent 70 to capture the flavor constituent. It should be noted that Step S20 and Step S30 are shown as different treatments in Fig. 4 for the convenience of illustration, but Step S20 and Step S30 are treatments which are carried out in parallel. Being carried out in parallel means that the period to carry out Step S30 overlaps with the period to carry out Step S20, and it should be noted that Step S20 and Step S30 do not need to start and finish at the same time.

40 **[0059]** In Step S20 and Step S30, the pressure in the container 11 in the treatment device 10 is not more than normal pressure. Specifically, the upper limit of the pressure in the container 11 in the treatment device 10 is +0.1 MPa or less

as gauge pressure. In addition, a reduced pressure atmosphere may be inside the container 11 in the treatment device 10.

[0060] As the capture solvent 70, for example, glycerin, water or ethanol can be used as described above. The temperature of the capture solvent 70 is normal temperature as described above. The lower limit of normal temperature is for example a temperature at which the capture solvent 70 is not solidified, preferably 10°C. The upper limit of normal temperature is for example 40°C or less.

[0061] In Step S40, in order to increase the concentration of a flavor constituent contained in a capture solution, the capture solvent 70 having captured the flavor constituent is subjected to a vacuum concentration treatment, a heating concentration treatment or a salting-out treatment. It should be noted however that the treatment of Step S40 (concentration treatment) is not essential and may be omitted.

[0062] The vacuum concentration treatment is preferably carried out in an airtight space to a degree in which the movement of air to the outside of the space can be inhibited. Therefore, contact with air is limited, and it is not required that the capture solvent 70 be raised to a high temperature, and thus there is a little concern about changes in components. Therefore, types of capture solvent which can be used increase by using vacuum concentration.

[0063] In the heating concentration treatment, there is concern about liquid denaturation, for example, oxidation of a flavor constituent, but there is a possibility that an effect for increasing a flavor is obtained. However, compared to the vacuum concentration, types of capture solvent which can be used are decreased. There is for example a possibility that a capture solvent having an ester structure such as MCT (Medium Chain Triglyceride) cannot be used.

[0064] In the salting-out treatment, compared to the vacuum concentration treatment, the concentration of a flavor constituent can be increased; however, the flavor constituent is divided fifty-fifty between the liquid solvent phase/water phase, and thus the yield rate of the flavor constituent is low. In addition, it is supposed that the coexistence of a hydrophobic substance (such as MCT) is essential, and thus there is a possibility that salting-out does not occur depending on the ratio between capture solvent, water and flavor constituent.

[0065] In Step S50, the tobacco raw material 50 which a flavor constituent has been released in Step S20 is prepared. It should be noted that the tobacco raw material 50 is still maintained in the closed space (in the above-described container 11 in the embodiment).

[0066] In Step S60 (i.e. step C2), a washing solvent (a second solvent) is supplied to the tobacco raw material 50 in the closed space (in the above-described container 11 in the embodiment), and a normal component which is released as the liquid phase from the tobacco raw material 50 to the washing solvent is taken with the washing solvent to the outside of the closed space (the outside of the above-described container 11 in the embodiment).

[0067] After a flavor constituent which has been contained in the tobacco raw material 50 is taken out in Step S30 (capture treatment), the residue from which the flavor constituent has been taken is washed with a washing solvent in Step S60 (washing treatment). Therefore, normal component (impurity substances) remaining in the tobacco raw material 50 (residue) are removed. Since the production method involved in the embodiment comprises Step S60 (washing treatment), unnecessary impurity substances can be simply removed from the tobacco raw material 50 (residue).

[0068] In the case where Step S60 (washing treatment) is carried out following Step S30 (capture treatment) using the treatment device 10, examples of washing modes can include a mode in which a washing solvent is sprayed to the tobacco raw material 50 (residue) from the spray 12 and then the container 11 is rotated and shaken for about 10 to 60 minutes to carry out washing.

[0069] At this time, the weight ratio of tobacco raw material 50 (residue) and washing solvent (washing solvent/residue) can include 10 to 20 when the tobacco raw material 50 (residue) is considered as 1.

[0070] The washing solvent used in Step S60 (washing treatment) can include aqueous solvents, and specific examples thereof can be pure water and ultrapure water, and can include city water. In addition, the temperature of the washing solvent can include between normal temperature (e.g. 20°C ± 15°C) and 70°C.

[0071] In the case where an aqueous solvent is used as a washing solvent, those through which CO₂ gas is bubbled may be used, and specifically can include carbonated water and an aqueous solution containing oversaturated CO₂ gas. In addition, an aqueous solvent, for example, water through which ozone is bubbled can be used.

[0072] Step S60 (washing treatment) may be repeated at least twice or more. In such case, when n is an integer of 1 or more, a solvent A is used as a washing solvent in the n-th step, and a solvent B different from the solvent A may be used as a washing solvent in the n + 1-th step. In the case where Step S60 (washing treatment) is repeated 3 times or more, three types or more of solvent may be used as a washing solvent. Further, when Step S60 (washing treatment) is repeated 3 times or more, the same solvent may be used in Step S60 (washing treatment) twice or more.

[0073] For example, when an aqueous solvent is used as a washing solvent, washing is initially carried out with water, and then washing may be carried out with an aqueous solvent through which CO₂ gas is bubbled. Each washing may be carried out several times. When washing is carried out by such procedure and aqueous solvent, impurity substances are efficiently removed.

[0074] Here, step S60 (a washing treatment) may be repeated at least two or more times using second solvents having respectively different temperatures. In such a case, step S60 (the washing treatment) may include a step of bubbling while adding CO₂ gas to the second solvent having the lowest temperature among the respectively different temperatures.

Step S60 (the washing treatment) may include a step of bubbling while adding CO₂ gas to the second solvent with a temperature of 20°C or less. By bubbling while adding CO₂ gas to the second solvent with relatively low temperature, it is possible to effectively neutralize and remove the alkaline substances (the basic substances such as potassium carbonate aqueous solution) added to the tobacco raw material 50 while controlling the decrease in solubility of CO₂ gas.

5 [0075] For example, step S60 (the washing treatment) may include a step in which water with a first temperature (for example, from 40 to 80°C) as a second solvent is used to take a normal component out of the closed space (below, a first washing step), and a step in which water with a second temperature (for example, from 10 to 15°C) lower than that of the first temperature as a second solvent is used and bubbling is performed while adding CO₂ gas to water with the second temperature to take a normal component out of the closed space (below, a second washing step). By performing the washing treatment by using water with the relatively high first temperature, the water-soluble contaminants are removed. By bubbling while adding CO₂ gas to water with a relatively low second temperature, the alkaline substances (the basic substances such as potassium carbonate aqueous solution) added on the tobacco raw material 50 may effectively be neutralized and removed while controlling the decrease in solubility of CO₂ gas. It is preferable to perform the second washing step after the first washing step. The first washing step may be performed more than two times. 10 The second washing step may be performed more than two times.

15 [0076] As the washing solvent, non-aqueous solvents such as propylene glycol, glycerin, ethanol, MCT), hexane, methanol and acetonitrile can be also used aside from the above-mentioned aqueous solvents. In addition, these can be used by mixing the above-mentioned aqueous solvents.

20 [0077] Instead of the above-described bubbling by using the CO₂ gas, an acidic solvent may be used as a washing solvent. For example, carboxylic acid such as acetic acid or malic acid may be mentioned as the acidic solvent.

[0078] After washing with a washing solvent, the residue may be subjected to a drying treatment. As the drying condition, a mode in which drying is carried out at a temperature of about 110 to 125°C for about 100 to 150 minutes with air circulated (ventilation amount 10 to 20 L/min/250 g) can be mentioned.

25 [0079] As described above, when Step S60 (washing treatment) is repeated several times, by using different types of washing solvent for each washing treatment, types of impurity component can be differentiated due to high affinity with a washing solvent, and several types of impurity component can be removed.

[0080] The residue obtained after the washing treatment in Step S60 (washing treatment) is used for Step S70 (return treatment) described below.

30 [0081] In Step S70 (i.e. step D), a capture solvent (first solvent) having captured a flavor constituent in Step S30 is added to the tobacco raw material 50 which the flavor constituent has been released to the outside of the closed space in Step S20 (the washed residue of the tobacco raw material) in the closed space (in the above-described container 11 in the embodiment). The capture solvent (first solvent) which is added to the tobacco raw material 50 (the washed residue of the tobacco raw material) may be neutralized in Step S70. Alternatively, after adding the capture solvent (first solvent) to the tobacco raw material 50 (the washed residue of the tobacco raw material) in Step S70, the tobacco raw material containing a flavor constituent may be neutralized. 35

[0082] By the treatments described above, a tobacco raw material containing a flavor constituent is produced. However, the treatment in Step S40 (concentration treatment) may be omitted as described above.

40 [0083] Here, step S70 (return treatment) may be performed outside of the closed space (in the embodiment, outside of the above-described container 11). Before step S70 (the return treatment) is performed, a grinding treatment and a granule forming treatment for the residue (the washed residue of the tobacco raw material) obtained from the washing treatment in step S60 (the washing treatment) may be performed. The grinding treatment, for example, is a process of grinding the washed residue of the tobacco raw material, while adding a binder to the ground residue, and mixing the ground residue and the binder. The granule forming treatment, for example, is a process of sizing and drying the mixture while stirring with a mixer, after kneading and extruding the mixture of the ground residue and the binder. The granule forming treatment may be performed simultaneously with step S70 (the return treatment). 45

[0084] It should be noted that the entire above-described wt% is percent by weight in the dry state.

(Action and Effect)

50 [0085] In the first embodiment, a capture solvent is allowed to capture a flavor constituent contained in a tobacco raw material by Step S20 (heating treatment) and Step S30 (capture treatment), and by carrying out Step S70 (return treatment) for adding the capture solvent having captured the flavor constituent to a tobacco raw material, impurities such as ammonia contained in the tobacco raw material can be selectively reduced by a simple and low-cost process.

55 [0086] Further, in the first embodiment, Step S60 (washing treatment) for washing a tobacco raw material is carried out prior to Step S70 (return treatment) for adding a capture solvent having captured a flavor constituent to a tobacco raw material. Therefore, impurity components such as TSNA are further selectively reduced.

[0087] In the first embodiment, because at least Step S20 (heating treatment) and Step S60 (washing treatment) are carried out with the tobacco raw material maintained in a closed space (in the above-described container 11 in the

embodiment), the tobacco raw material is maintained in a sanitary condition, and the vaporization of a flavor constituent contained in the tobacco raw material is inhibited, and it is not required to transfer the tobacco raw material. Therefore the loss of the tobacco raw material is limited.

5 [Modified Example 1]

[0088] The modified example 1 of the first embodiment will be described below. Differences from the first embodiment will be mainly described below.

10 [0089] In the modified example 1, the above-described Step S30 (capture treatment) is carried out until any time from when the first condition is satisfied to when the second condition is satisfied.

[0090] The first condition is a condition that when, after the pH of a capture solution containing the capture solvent 70 and the release component 62 decreases by 0.2 or more from the maximum value, a stable zone in which variations in the pH of the capture solution are within a predetermined range exists in the time axis elapsing from the beginning of Step S20, the time elapsing from the beginning of Step S20 (hereinafter, treatment time) reaches the start time of the stable zone.

15 [0091] The stable zone is a zone in which variations in the pH of a capture solution are within a predetermined range (e.g. the average variation per unit of time is $\pm 0.01/\text{min}$), and in such zone, the range of variation in the pH of a capture solution is within a predetermined range (e.g. a difference between pH at a time when such zone starts and pH at a time when the second condition described below is satisfied is ± 0.2). In a case where a stable zone in which variations in the pH of a capture solution are within a predetermined range exists after the pH of the capture solution decreases by 0.2 or more from the maximum value, the start time of the stable zone is for example a time when the pH of the capture solution stops decreasing.

20 [0092] The profile of the pH of a capture solution is measured in advance in the same conditions as in the actual treatments, and the pH of a capture solution is preferably replaced with treatment time. That is, the first condition is preferably replaced with treatment time. Therefore, it is not required to monitor variations in the pH of a capture solution in real time and ammonium ion (NH_4^+) can be removed from the capture solution by simple control.

25 [0093] The second condition is a condition that, in the case where the weight of the tobacco raw material 50 in the dry state is 100 wt%, the remaining amount of flavor constituent (herein, a nicotine component) contained in the tobacco raw material 50 decreases until reaching 0.3 wt%. Further preferably, the second condition is a condition that, in the case where the weight of the tobacco raw material 50 in the dry state is 100 wt%, the remaining amount of flavor constituent (herein, a nicotine component) contained in the tobacco raw material 50 decreases until reaching 0.4 wt%. Further preferably, the second condition is a condition that, in the case where the weight of the tobacco raw material 50 in the dry state is 100 wt%, the remaining amount of flavor constituent (herein, a nicotine component) contained in the tobacco raw material 50 decreases until reaching 0.6 wt%.

30 [0094] The profile of the remaining amount of flavor constituent (herein, a nicotine component) contained in the tobacco raw material 50 is measured in advance in the same conditions as in the actual treatments, and the remaining amount of flavor constituent is preferably replaced with treatment time. That is, the second condition is preferably replaced with treatment time. Therefore, it is not required to monitor the remaining amount of flavor constituent in real time and an increase in the amount of TSNA contained in a capture solvent can be inhibited by simple control.

35 [0095] In the modified example 1, the total amount of saccharides contained in the tobacco raw material 50 is 10.0 wt% or less in the case where the gross weight of the tobacco raw material 50 in the dry state is 100 wt%. The saccharides contained in the tobacco raw material 50 are fructose, glucose, saccharose, maltose and inositol. Therefore, the stable zone of pH showing that the concentration of ammonium ion in a capture solution was sufficiently reduced can be clearly confirmed.

40
45 (Action and Effect)

[0096] In the modified example 1, Step S30 for bringing a release component into contact with the capture solvent 70 is continued at least until the first condition is satisfied. Therefore, ammonium ion (NH_4^+) contained in the release component is sufficiently removed from the capture solution. In addition, in the release from the tobacco raw material 50 and the extraction by a capture solvent, other volatile impurity components (specifically, acetaldehyde, pyridine) showing the same behavior as of ammonium ion are also removed from a capture solution by satisfying the first condition.

[0097] In the meantime, Step S30 for bringing a release component into contact with the capture solvent 70 is finished at least by the time when the second condition is satisfied. Therefore, by finishing S30 prior to the amount of TSNA released increases, an increase in the amount of TSNA contained in a capture solution is inhibited.

50 [0098] As described above, by simple treatments such as Step S20 and Step S30, as contamination by impurity components such as ammonium ion (NH_4^+) and TSNA is inhibited, a flavor constituent can be sufficiently extracted. That is, a flavor constituent can be extracted by a simple device.

5 [0099] In the modified example 1, non-volatile components contained in the tobacco raw material 50 do not move to a capture solvent, and only components volatilized at about 120°C can be captured in the capture solvent, and thus components captured by a capture solvent can be used as an aerosol source for electronic cigarettes. Therefore, as an increase in volatile impurity components such as ammonium ion, acetaldehyde and pyridine is inhibited in electronic cigarettes, aerosol containing a tobacco flavor can be delivered to users, and further the movement of non-volatile components to the capture solvent is inhibited, and thus scorching of a heater to heat an aerosol source, and the like can be inhibited. The term "electronic cigarette" herein indicates a non-combustion type flavor inhaler or aerosol inhaler which comprises an electric heater to heat and atomize a liquid aerosol source and an aerosol source and is to deliver aerosol to users (e.g. an aerosol inhaler described in Japanese Patent No. 5196673, an aerosol electronic cigarette described in Japanese Patent No. 5385418, etc.)

[Modified Example 2]

15 [0100] The modified example 2 of the first embodiment will be described below. Differences from the first embodiment will be mainly described below.

[0101] In the modified example 2, the above-described Step S30 (capture treatment) is carried out until any time from when the first condition is satisfied to when the second condition is satisfied.

20 [0102] The first condition is a condition that, in the case where the weight of the tobacco raw material in the dry state is 100 wt%, the remaining amount of flavor constituent (herein, a nicotine component) contained in the tobacco raw material decreases until reaching 1.7 wt%.

25 [0103] The second condition is a condition that, in the case where the weight of the tobacco raw material 50 in the dry state is 100 wt%, the remaining amount of flavor constituent (herein, a nicotine component) contained in the tobacco raw material 50 decreases until reaching 0.3 wt%. Further preferably, the second condition is a condition that, in the case where the weight of the tobacco raw material 50 in the dry state is 100 wt%, the remaining amount of flavor constituent (herein, a nicotine component) contained in the tobacco raw material 50 decreases until reaching 0.4 wt%. Further preferably, the second condition is a condition that, in the case where the weight of the tobacco raw material 50 in the dry state is 100 wt%, the remaining amount of flavor constituent (herein, a nicotine component) contained in the tobacco raw material 50 decreases until reaching 0.6 wt%.

30 [0104] The profile of the remaining amount of flavor constituent (herein, a nicotine component) contained in the tobacco raw material 50 is measured in advance in the same conditions as in the actual treatments, and the remaining amount of flavor constituent is preferably replaced with treatment time. That is, the second condition is preferably replaced with treatment time. Therefore, it is not required to monitor the remaining amount of flavor constituent in real time and an increase in the amount of TSNA contained in a capture solvent can be inhibited by simple control.

35 (Action and Effect)

40 [0105] In the modified example 2, Step S30 for bringing a release component into contact with the capture solvent 70 is continued at least until the first condition is satisfied. Therefore, Step S30 is continued in a zone in which the decrease rate of the remaining amount of flavor constituent contained in a tobacco raw material (i.e. a rate at which a nicotine component is volatilized from the tobacco raw material 50) is not less than a predetermined rate, and therefore the flavor constituent can be efficiently recovered. In the meantime, Step S30 for bringing a release component into contact with the capture solvent 70 is finished at least by the time when the second condition is satisfied. Therefore, by finishing S30 before the amount of TSNA released increases, an increase in the amount of TSNA contained in a capture solution is inhibited.

45 [0106] As described above, by the simple treatments such as Step S20 and Step S30, as contamination by impurity components such as TSNA is inhibited, a flavor constituent can be sufficiently extracted. That is, a flavor constituent can be extracted by a simple device.

50 [0107] In the modified example 2, non-volatile components contained in the tobacco raw material 50 do not move to a capture solvent, and only components volatilized at about 120°C can be captured in the capture solvent, and thus components captured by a capture solvent can be used as an aerosol source for electronic cigarettes. Therefore, as an increase in volatile impurity components such as ammonium ion, acetaldehyde and pyridine is inhibited in electronic cigarettes, aerosol containing a tobacco flavor can be delivered to users, and further the movement of non-volatile components to a capture solvent is inhibited, and thus scorching of a heater to heat an aerosol source, and the like can be inhibited. The term "electronic cigarette" herein indicates a non-combustion type flavor inhaler or aerosol inhaler which comprises an electric heater to heat and atomize a liquid aerosol source and an aerosol source and is to deliver aerosol to users (e.g. an aerosol inhaler described in Japanese Patent No. 5196673, an aerosol electronic cigarette described in Japanese Patent No. 5385418, etc.).

[Experimental results]

(First experiment)

5 **[0108]** In the first experiment, samples (Sample A to Sample D) shown in Fig. 5 were prepared and the pH of a capture solution and ammonium ion (NH_4^+) contained in a capture solution were measured under the following conditions.

10 **[0109]** The amount of nicotine (Nic. amount) and the amount of ammonium ion (NH_4^+ amount) contained in Sample A to Sample D in the dry state are as shown in Fig. 5. The amount of every saccharide (fructose, glucose, saccharose, maltose and inositol) contained in Sample A is almost zero (less than the detection limit), the total amount of saccharides (fructose, glucose, saccharose, maltose and inositol) contained in Sample B is 9.37 wt%, the total amount of saccharides (fructose, glucose, saccharose, maltose and inositol) contained in Sample C is 18.81 wt%, and the amount of saccharides (fructose, glucose, saccharose, maltose and inositol) contained in Sample D is 0.02 wt%. In addition, the measurement results of the pH of a capture solution are as shown in Fig. 6, and the measurement results of ammonium ion (NH_4^+) contained in a capture solution are as shown in Fig. 7. In Fig. 6 and Fig. 7, the treatment time is a time elapsing from the beginning of the heating treatment (S20) of a tobacco raw material. It can be thought that the treatment time is a time elapsing from the beginning of the capture treatment (S30) of a flavor constituent (hereinafter, a nicotine component).

-Experimental conditions-

20 **[0110]**

- Heating temperature of tobacco raw material: 120°C
- pH of tobacco raw material after alkali treatment: 9.6
- initial amount of water in tobacco raw material after alkali treatment: 39% \pm 2%
- 25 • Type of capture solvent: glycerin
- Temperature of capture solvent: 20°C
- Amount of capture solvent: 61 g
- Aeration flow during bubbling treatment (aeration treatment and capture treatment): 15 L/min

30 **[0111]** The gas used in the bubbling treatment (aeration treatment) is the atmosphere at about 20°C and about 60%-RH.

[0112] It was verified that in the profile of the pH of a capture solution, a stable zone in which variations in the pH of a capture solution are within a predetermined range existed after the pH of the capture solution decreased by 0.2 or more from the maximum value in Sample A as shown in Fig. 6. It was verified that the concentration of ammonium ion (NH_4^+) contained in a capture solution was sufficiently reduced at a time when the stable zone starts (e.g. treatment time = 40 minutes) as shown in Fig. 7.

35 **[0113]** On the other hand, it was verified that in the profile of the pH of a capture solution, a zone in which the pH of a capture solution decreases by 0.2 or more from the maximum value did not exist in Sample B as shown in Fig. 6. It was verified that in the profile of the pH of a capture solution, the pH of a capture solution was intermittently reduced and the above-described stable zone did not exist in Sample C as shown in Fig. 6.

40 **[0114]** The stable zone is a zone in which variations in the pH of a capture solution is within a predetermined range (e.g. the average variation per unit of time is $\pm 0.01/\text{min}$) as described above, and in such zone, the range of variation in the pH of a capture solution is within a predetermined range (e.g. a difference between pH at a time when such zone starts and pH at a time when the second condition described below is satisfied is ± 0.2).

45 **[0115]** It was verified that by the heating treatment and the capture treatment, saccharides (fructose, glucose, saccharose, maltose and inositol) contained in a tobacco raw material decreased and volatile organic acids (acetic acid, formic acid) increased. In addition, the increased amount of volatile organic acids was Sample C > Sample B > Sample A, and it was verified that in a sample with a higher amount of saccharides contained in a tobacco raw material, the increased amount of volatile organic acids was higher. It is thought that this is because acid substances are produced by degradation of saccharides and move to a capture solution. In other words, it was verified that by using a burley type tobacco raw material with a low amount of saccharides contained in the tobacco raw material like Sample A, specifically a tobacco raw material in which the total amount of saccharides contained in the tobacco raw material is 10.0 wt% or less, the stable zone of pH showing that the concentration of ammonium ion in a capture solution was sufficiently reduced could be clearly confirmed. In addition, by daring to use a burley type tobacco raw material with a high concentration of ammonium ion (NH_4^+), a profile with a pH decrease is easily confirmed. Furthermore, by the reducing treatment of ammonium ion (NH_4^+), volatile impurity components (specifically, acetaldehyde, pyridine) showing the same release and capture behavior as of ammonium ion (NH_4^+) are also reduced at the same time, and thus volatile impurity components (specifically, acetaldehyde, pyridine) are easily reduced.

55 **[0116]** Such experimental results verified that in a case where, after the pH of a capture solution decreased by 0.2 or

more from the maximum value, a stable zone in which variations in the pH of a capture solution are within a predetermined range existed in the profile of the pH of a capture solution like Sample A, when the treatment time went through the start time of the stable zone, the concentration of ammonium ion (NH_4^+) was sufficiently reduced. That is, it was verified that preferably the first condition was a condition that the treatment time reaches the start time of the stable zone.

(Second experiment)

[0117] In the second experiment, a sample of burley type tobacco raw material (the above-described Sample A) was prepared, and the remaining amount of alkaloid (herein, a nicotine component) contained in the tobacco raw material in the dry state (hereinafter, nicotine concentration in tobacco raw material), and the concentration of TSNA contained in a capture solution (hereinafter, TSNA concentration in capture solution) were measured under the following conditions.

[0118] The measurement results of the nicotine concentration in tobacco raw material are as shown in Fig. 8, and the measurement results of the concentration of TSNA contained in a capture solution are as shown in Fig. 9. The remaining amount of nicotine component contained in a tobacco raw material is represented by percent by weight in a case where the weight of a tobacco raw material in the dry state is 100 wt%. The concentration of TSNA contained in a capture solution is represented by percent by weight in a case where a capture solution is 100 wt%. In Fig. 8 and Fig. 9, the treatment time is a time elapsing from the beginning of the heating treatment (S20) of a tobacco raw material. It can be also thought that the treatment time is a time elapsing from the beginning of the capture treatment (S30) of a nicotine component.

[0119] About four types of TSNA, 4-(methylnitrosamino)-1-(3-pyridyl)-1-butanone (hereinafter, NNK), N'-nitrosornicotine (hereinafter, NNN), N'-nitrosoanatabine (hereinafter, NAT) and N'-nitrosoanabasine (hereinafter, NAB), these concentrations were measured.

-Experimental conditions-

[0120]

- Heating temperature of tobacco raw material: 120°C
- pH of tobacco raw material after alkali treatment: 9.6
- Initial amount of water in tobacco raw material after alkali treatment: 39% ± 2%
- Type of capture solvent: glycerin
- Temperature of capture solvent: 20°C
- Amount of capture solvent: 60 g
- Aeration flow during bubbling treatment (aeration treatment and capture treatment): 15 L/min

[0121] The gas used in the bubbling treatment (aeration treatment) is the atmosphere at about 20°C and about 60%-RH.

[0122] As shown in Fig. 8, the remaining amount of nicotine component contained in a tobacco raw material intermittently decreases in the profile of the nicotine concentration in tobacco raw material. As shown in Fig. 9, it was verified that NNK did not change but NNN, NAT and NAB increased after a lapse of a fixed period in the profile of the concentration of TSNA.

[0123] Specifically, it was verified that when the treatment time went through a time when the nicotine concentration in tobacco raw material reaches 0.3 wt% (300 minutes in the present experimental result), the decrease rate of the remaining amount of nicotine component contained in a tobacco raw material (i.e. a rate at which the nicotine component is volatilized from the tobacco raw material) declined, and a rise in the recovery rate of nicotine component was not expected. It was also verified that when the treatment time went through a time when the nicotine concentration in tobacco raw material reaches 0.4 wt% (180 minutes in the present experimental result), NAB gradually increased. It was further verified that when the treatment time went through a time when the nicotine concentration in tobacco raw material reaches 0.6 wt% (120 minutes in the present experimental result), NNN and NAT considerably increased.

[0124] Such experimental results verified that preferably the heating treatment (S20) and the capture treatment (S30) were finished before the time when the nicotine concentration in tobacco raw material reaches 0.3 wt%. That is, it was verified that preferably the second condition was that the nicotine concentration in tobacco raw material decreases until reaching 0.3 wt%. It was verified that further preferably the heating treatment (S20) and the capture treatment (S30) were finished before the time when the nicotine concentration in tobacco raw material reaches 0.4 wt%. That is, it was verified that further preferably the second condition was that the nicotine concentration in tobacco raw material decreases until reaching 0.4 wt%. It was verified that further preferably the heating treatment (S20) and the capture treatment (S30) were finished before the time when the nicotine concentration in tobacco raw material reaches 0.6 wt%. That is, it was verified that further preferably the second condition was that the nicotine concentration in tobacco raw material decreases until reaching 0.6 wt%.

(Third experiment)

[0125] In the third experiment, Sample P to Sample Q were prepared and the pH of a capture solution and the concentration of alkaloid (herein, a nicotine component) in a capture solution were measured under the following conditions. Sample P is a sample using glycerin as a capture solvent. Sample Q is a sample using water as a capture solvent. Sample R is a sample using ethanol as a capture solvent. The measurement results of the pH of a capture solution are as shown in Fig. 10. The measurement results of the concentration of nicotine component contained in a capture solution are as shown in Fig. 11. In Fig. 10 and Fig. 11, the treatment time is a time elapsing from the beginning of the heating treatment (S20) of a tobacco raw material. It can be thought that the treatment time is a time elapsing from the beginning of the capture treatment (S30) of a nicotine component.

- Experimental conditions -

[0126]

- Type of tobacco raw material; burley type
- Heating temperature of tobacco raw material: 120°C
- pH of tobacco raw material after alkali treatment: 9.6
- Temperature of capture solvent: 20°C
- Amount of capture solvent: 60 g
- Aeration flow during bubbling treatment (aeration treatment and capture treatment): 15 L/min

[0127] The gas used in the bubbling treatment (aeration treatment) is the atmosphere at about 20°C and about 60%-RH.

[0128] As shown in Fig. 10, when glycerin, water or ethanol was used as a capture solvent, the absolute values of pH of a capture solution in the stable zone were different, but a significant difference between capture solvents was not shown as the profile of the pH of a capture solution. Similarly, as shown in Fig. 13, when glycerin, water or ethanol was used as a capture solvent, a significant difference between the concentrations of nicotine component contained in a capture solution was not shown.

[0129] Such experimental results verified that glycerin, water or ethanol could be used as a capture solvent.

(Fourth experiment)

[0130] In the fourth experiment, the weight of ammonium ion and pyridine contained in a capture solution was measured by changing the temperature of a capture solvent under the following conditions. The weight of ammonium ion contained in a capture solution is as shown in Fig. 12. The weight of pyridine contained in a capture solution is as shown in Fig. 13.

- Experimental conditions -

[0131]

- Type of tobacco raw material; burley type
- Heating temperature of tobacco raw material: 120°C
- pH of tobacco raw material after alkali treatment: 9.6
- Type of capture solvent: glycerin
- Amount of capture solvent: 60 g

[0132] First, it was verified that when the temperature of a capture solvent was 10°C or more, ammonium ion could be efficiently removed as shown in Fig. 12. In the meantime, it was verified that even when the temperature of a capture solvent was not controlled, ammonium ion could be efficiently removed. The vaporization of alkaloid (herein, a nicotine component) from a capture solution is inhibited as long as the temperature of a capture solvent is 40°C or less. From such viewpoint, by setting the temperature of a capture solvent to 10°C or more and 40°C or less, as the vaporization of a nicotine component from a capture solution is inhibited, ammonium ion can be efficiently removed from the capture solution.

[0133] Second, it was verified that in the case where the temperature of a capture solvent was 10°C or more, pyridine could be efficiently removed as shown in Fig. 13. In the meantime, it was verified that even when the temperature of a capture solvent was not controlled, pyridine could be efficiently removed. The vaporization of a nicotine component from a capture solution is inhibited as long as the temperature of a capture solvent is 40°C or less. From such viewpoint, by setting the temperature of a capture solvent to 10°C or more and 40°C or less, as the vaporization of a nicotine component

EP 3 207 809 A1

from a capture solution is inhibited, pyridine can be efficiently removed from the capture solution.

[0134] The temperature of a capture solvent is the preset temperature of the chiller (a constant-temperature bath) controlling the temperature of a container containing the capture solvent. It should be noted that the temperature of a capture solvent is settled about 60 minutes after the container is set in the chiller and the temperature control starts.

[Measurement method]

(Method for measuring pH of capture solution)

[0135] A capture solution was left to stand in a sealed container until room temperature in a laboratory controlled at room temperature of 22°C to harmonize the temperature. After harmonization, the lid was opened, and the glass electrode of a pH meter (SevenEasy S20 manufactured by METTLER TOLEDO) was soaked in a capture solution to start the measurement. The pH meter was calibrated in advance using pH meter calibration liquids with pH 4.01, 6.87 and 9.21. A point at which output variations from a sensor become stable within 0.1 mV for 5 seconds was used as the pH of a capture solution.

(Method for measuring NH₄⁺ contained in capture solution)

[0136] A capture solution was collected in an amount of 50 µL, and diluted by adding 950 µL of a 0.05 N aqueous solution of dilute sulfuric acid, and the diluted solution was analyzed by ion chromatography to quantitate ammonium ion contained in the capture solution.

(Method for measuring nicotine component contained in tobacco raw material)

[0137] The measurement was carried out in a method in accordance with the German Institute for Standardization (DIN) 10373. That is, a tobacco raw material was collected in an amount of 250 mg, and 7.5 mL of a 11% aqueous solution of sodium hydroxide and 10 mL of hexane were added thereto, and shaking extraction was carried out for 60 minutes. After the extraction, the hexane phase, supernatant, was used for a gas chromatograph mass spectrometer (GC/MS) to quantitate the weight of nicotine contained in the tobacco raw material.

(Method for measuring amount of water contained in tobacco raw material)

[0138] A tobacco raw material was collected in an amount of 250 mg, and 10 mL of methanol was added thereto, and shaking extraction was carried out for 60 minutes. After the extraction, the extract liquid was filtered with a 0.45 µm membrane filter, and used for a gas chromatograph with thermal conductivity detector (GC/TCD) to quantitate the amount of water contained in the tobacco raw material.

[0139] The weight of the tobacco raw material in the dry state is calculated by subtracting the above-described amount of water from the gross weight of the tobacco raw material.

(Method for measuring TSNA contained in capture solution)

[0140] A capture solution was collected in an amount of 0.5 mL, and diluted by adding 9.5 mL of a 0.1 M aqueous solution of ammonium acetate, and the diluted solution was analyzed by a high performance liquid chromatograph-mass spectrometer (LC-MS/MS) to quantitate TSNA contained in the capture solution.

(GC analysis conditions)

[0141] The conditions of GC analysis used to measure the amounts of nicotine component and water contained in a tobacco raw material are as shown in Table given below.

[Table 1]

	Nicotine	Moisture
Model number of device (Manufacturer)	Agilent 6890GC&5975MSD (Agilent technologies)	HP 6890 (Hewlett Packard)
GC column	DB-1ms	DB-WAX

[Other embodiments]

[0142] The present invention is described by way of the embodiment described above. It should not be understood however that the present invention is limited to the description and figures forming parts of this disclosure. Various alternate embodiments, examples and operation techniques will be apparent to one skilled in the art by this disclosure.

[0143] In the embodiment, a case in which the same treatment device 10 (container 11) is used in Step S10 (alkali treatment) and Step S60 (washing treatment) was exemplified. The embodiment is not however limited thereto. For example, a tobacco raw material which has been subjected to the alkali treatment and water addition treatment in advance is placed in the container 11 and Step S20 (heating treatment), Step S30 (capture treatment) and Step S60 (washing treatment) may be carried out.

[0144] It is preferred that the volume of a closed space formed by the container 11 used in Step S20 (heating treatment) and Step S60 (washing treatment) not be extremely different from the volume of a tobacco raw material from the viewpoint of reducing the loss of a tobacco raw material by reducing the inner surface of the closed space, which is not described in detail in the embodiment. It is also preferred that the volume of the closed space not be extremely different from the volume of a tobacco raw material from the viewpoint of efficient washing. It is preferred that the shape of the closed space formed by the container 11 not contain an extremely long part and the like from the viewpoint of reducing the loss of a tobacco raw material by reducing the inner surface of the closed space. It is also preferred that the shape of the closed space not contain an extremely long part and the like from the viewpoint of efficient washing. It is preferred that the volume of the closed space be for example 3 times or more and 50 times or less the volume of a tobacco raw material. About the shape of the closed space, it is also preferred that when the lengths of the longest parts in the X direction, the Y direction and the Z direction which are directions intersecting each other at 90 degrees in the closed space are considered as X, Y and Z respectively and two values between X, Y and Z which differ most are used as L and S (S is a value smaller than L), L be 10 times or less higher than S. As long as the volume and shape of the closed space are as described above, the loss of a tobacco raw material can be reduced, and further a tobacco raw material (residue) can be sufficiently washed in Step S60 (washing treatment) using a moderate amount of solvent while moderately stirring the tobacco raw material.

[0145] It should be noted that when the inner surface of the closed space is reduced or an extremely long part and the like are not contained in the shape of the closed space, the contact area of a tobacco raw material with the inner surface of the closed space decreases, and a tobacco raw material adhering to the inner surface of the closed space also decreases, thereby reducing the loss of the tobacco raw material.

[0146] In the embodiment, the washing treatment (Step S60) is carried out prior to the return treatment (Step S70). The embodiment is not however limited thereto. The washing treatment (Step S60) may be omitted.

INDUSTRIAL APPLICABILITY

[0147] According to the present invention, there can be provided a method for producing a tobacco raw material, wherein the method can selectively reduce an impurity component contained in a tobacco raw material by a simple and low-cost process.

Claims

1. A producing method of a tobacco raw material containing a flavor constituent, comprising:

a step A for heating a tobacco raw material in a closed space which is treated with alkali and for taking a flavor constituent released in the gas phase from the tobacco raw material to an outside of the closed space;

a step B for allowing a first solvent to capture the flavor constituent by bringing the flavor constituent released in the gas phase in the step A into contact with the first solvent which is a liquid substance at normal temperature on the outside of the closed space;

a step C for supplying a second solvent to the tobacco raw material in the closed space after the step A and for taking a normal component which is released as the liquid phase from the tobacco raw material to the second solvent, together with the second solvent to the outside of the closed space; and

after the steps B and C, the step D for adding the first solvent capturing the flavor constituent in the step B to the tobacco raw material from which the flavor constituent is released to the outside of the closed space in the step A.

2. The production method according to claim 1, wherein the step D is, in the closed space after the steps B and C, a step for adding the first solvent capturing the flavor constituent in the step B to the tobacco raw material from which

the flavor constituent is released to the outside of the closed space in the step A in the closed space.

3. The production method according to claim 1 or 2, wherein the step C is repeated at least twice or more before the step D.

5

4. The production method according to claim 3, wherein when n is an integer of 1 or more,

10

a solvent A is used as the second solvent in the n-th step C, and a solvent B different from the solvent A is used as the second solvent in the n + 1-th step C.

5. The producing method according to claim 3 or 4, wherein the step C is repeated at least two or more times using the second solvents having respectively different temperatures.

15

6. The producing method according to claim 5, wherein the step C includes a step of bubbling while adding CO₂ gas to the second solvent having a lowest temperature among different temperatures.

20

7. The producing method according to claim 5 or 6, wherein the step C includes a step of bubbling while adding CO₂ gas to the second solvent having a temperature of 20°C or less.

25

8. The producing method according to any one of claims 1 to 7, wherein the step C includes:

taking the normal component out of the closed space by using water having a first temperature as the second solvent; and

30

taking the normal component out of the closed space by bubbling while adding CO₂ gas to a water having a second temperature as a second solvent, the second temperature being lower than the first temperature.

9. The production method according to any one of claims 1 to 4, wherein the step A comprises a step in which the tobacco source is subjected to a water addition treatment.

35

10. The production method according to claim 9, wherein in the step A, an amount of water in the tobacco source before heating the tobacco source becomes 30 wt% or more by the water addition treatment.

11. The production method according to any one of claims 1 to 10, wherein the step A comprises a step for adding a non-aqueous solvent to the tobacco raw material.

40

12. The production method according to claim 11, wherein the amount of the non-aqueous solvent is 10 wt% or more with respect to the tobacco raw material.

45

13. The production method according to claim 11 or 12, wherein the step A comprises a step for adding the non-aqueous solvent and water to the tobacco raw material.

14. The production method according to any one of claims 1 to 13, wherein a temperature of the first solvent is 10°C or more and 40°C or less.

50

55

55

FIG. 1

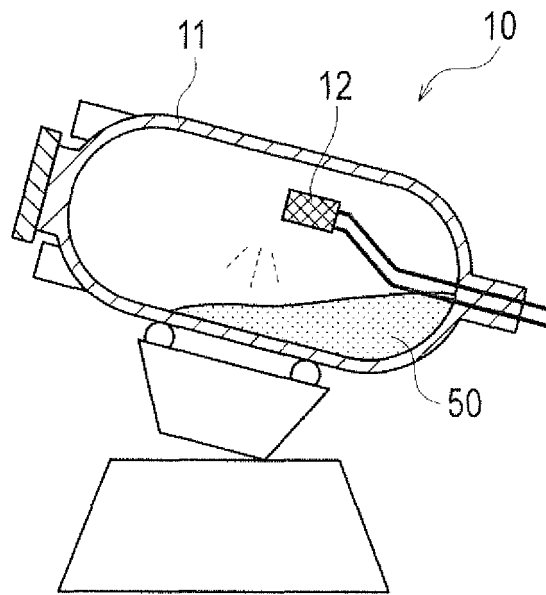

FIG. 2

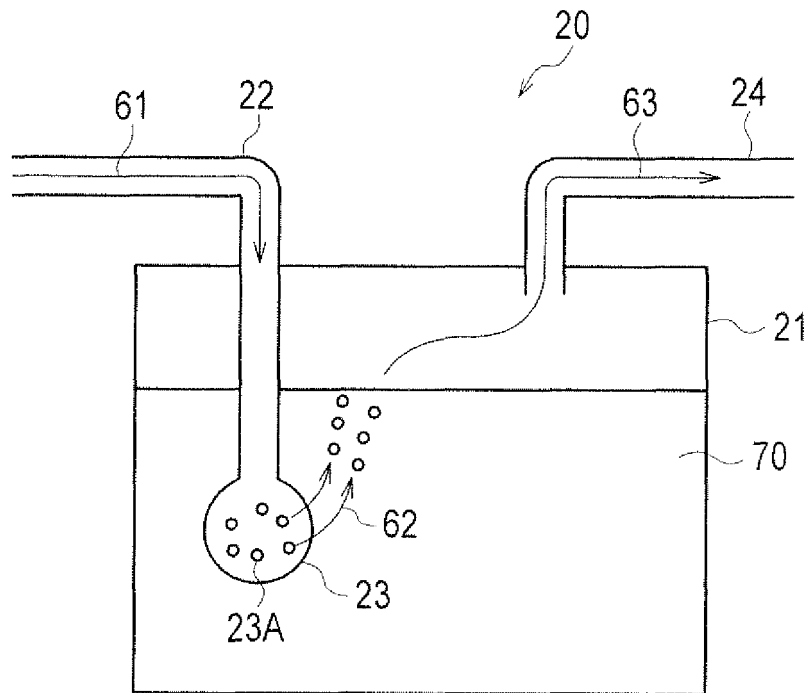

FIG. 3

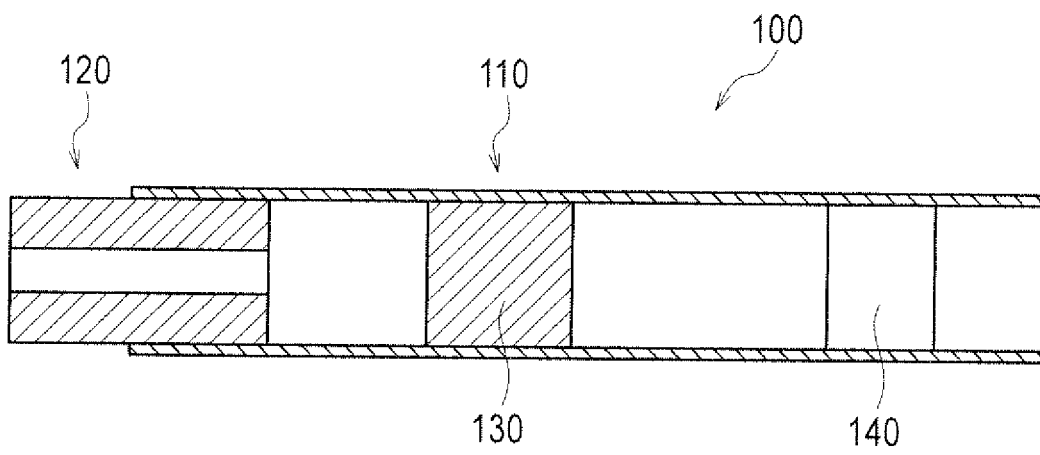

FIG. 4

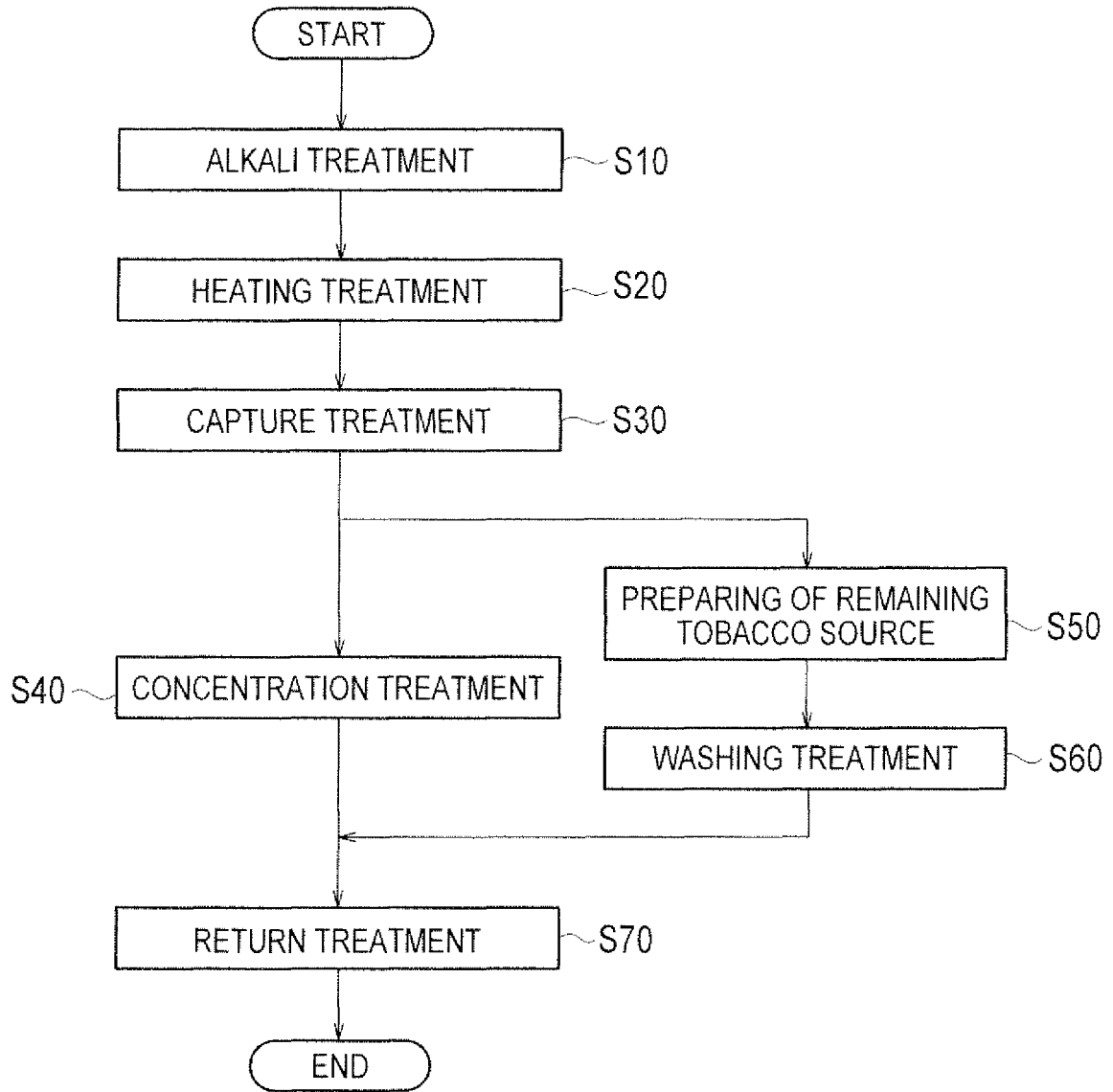

FIG. 5

SAMPLE	TYPE	Nic. AMOUNT [wt%-DB]	NH ₄ ⁺ AMOUNT [ug/g-DB]
SAMPLE A	BURLEY TYPE	4.9	4545
SAMPLE B	FLUE CURED TYPE	4.2	568
SAMPLE C	FLUE CURED TYPE	1.8	543

FIG. 6

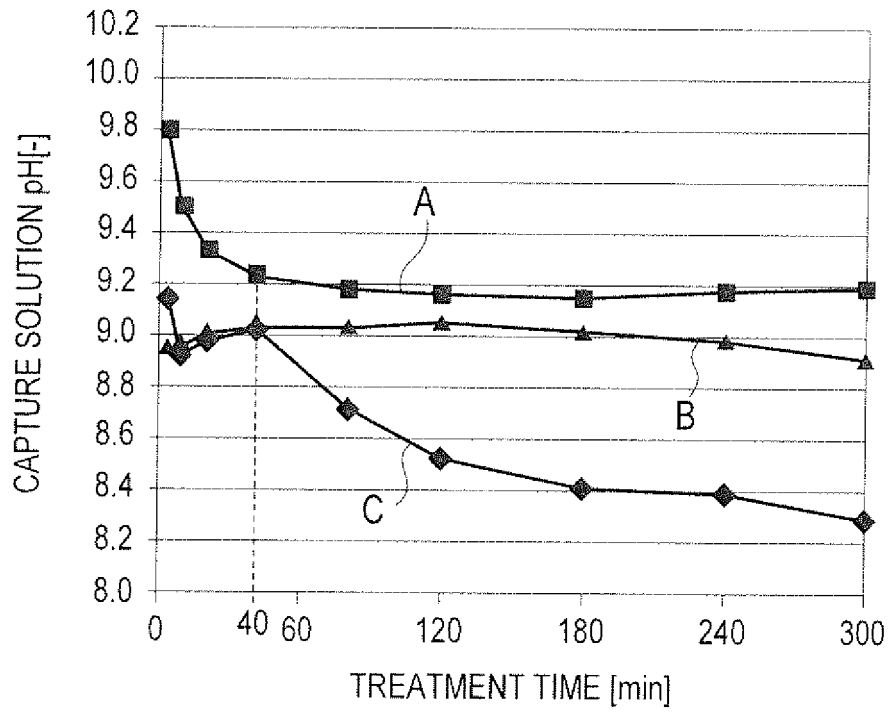

FIG. 7

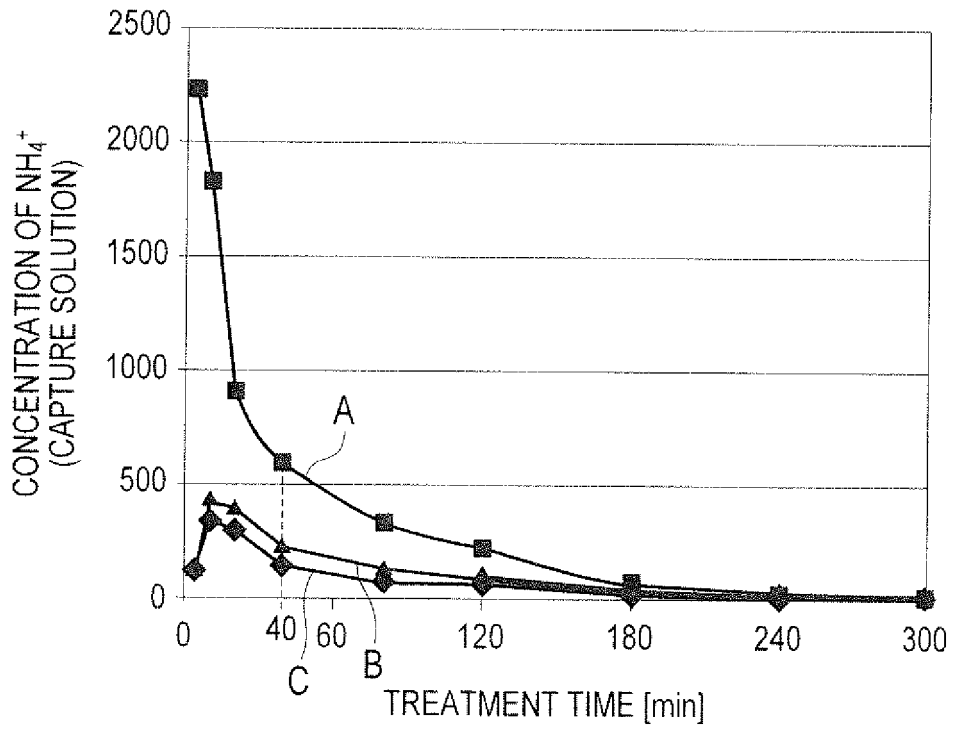

FIG. 8

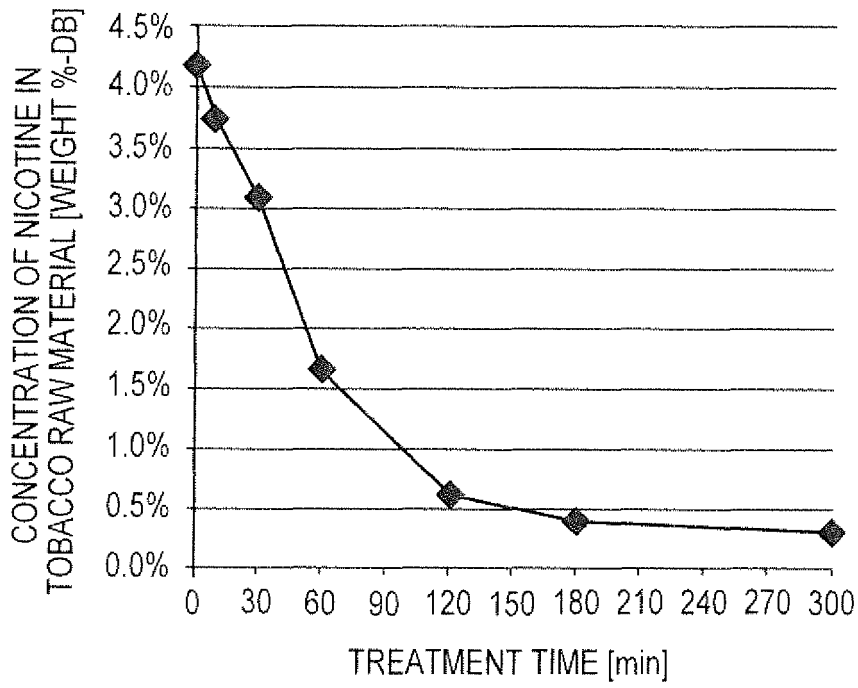

FIG. 9

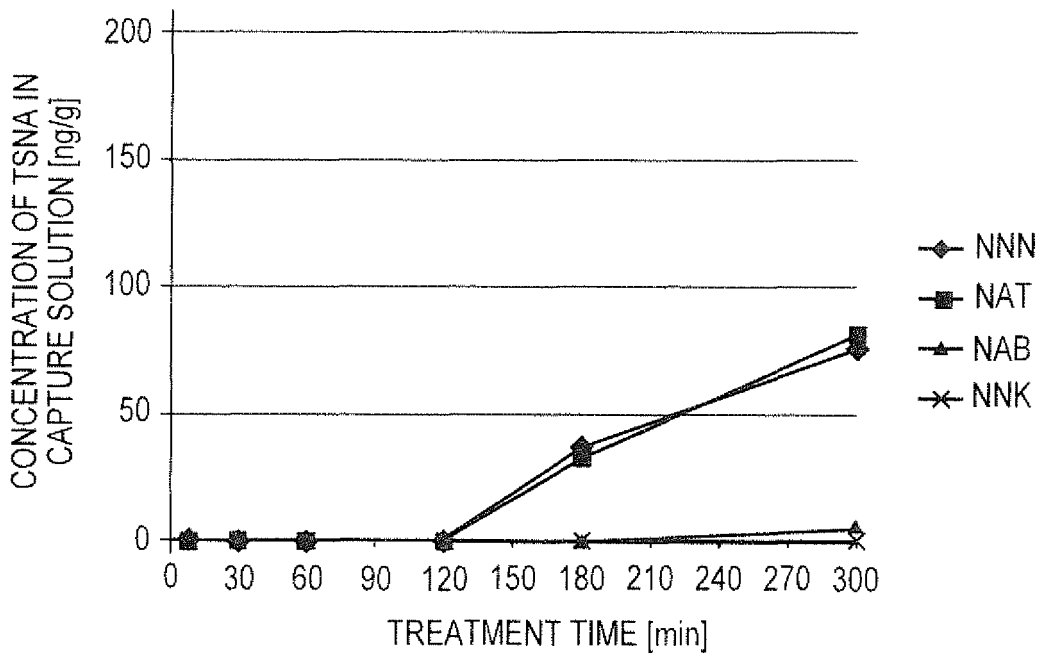

FIG. 10

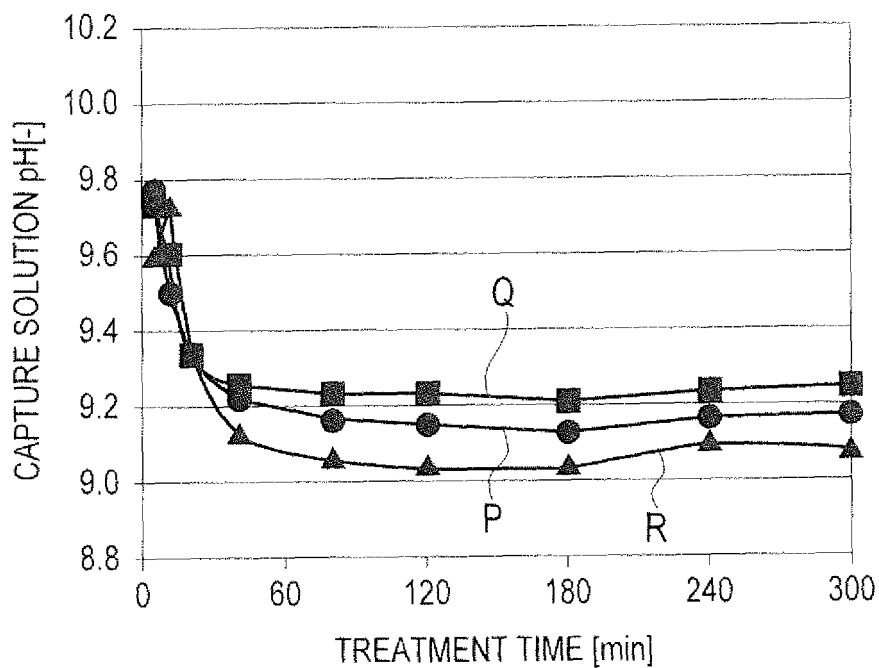

FIG. 11

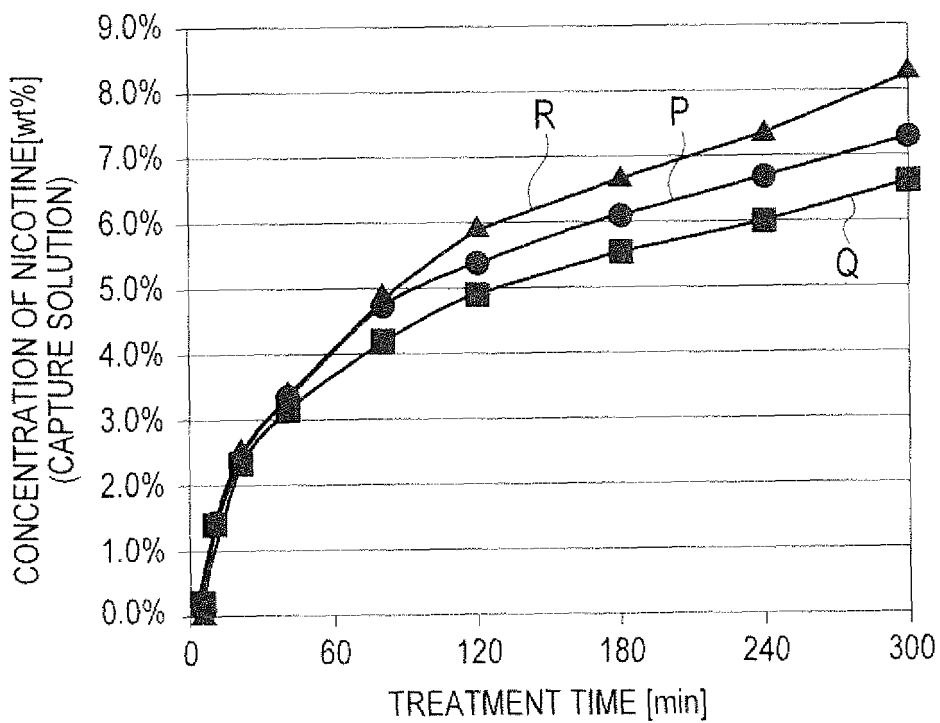

FIG. 12

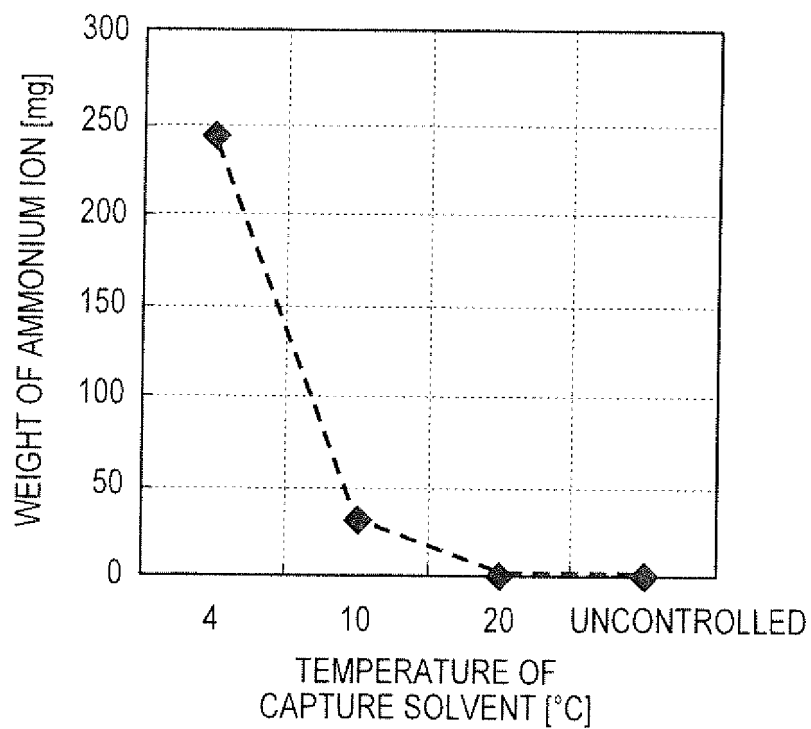
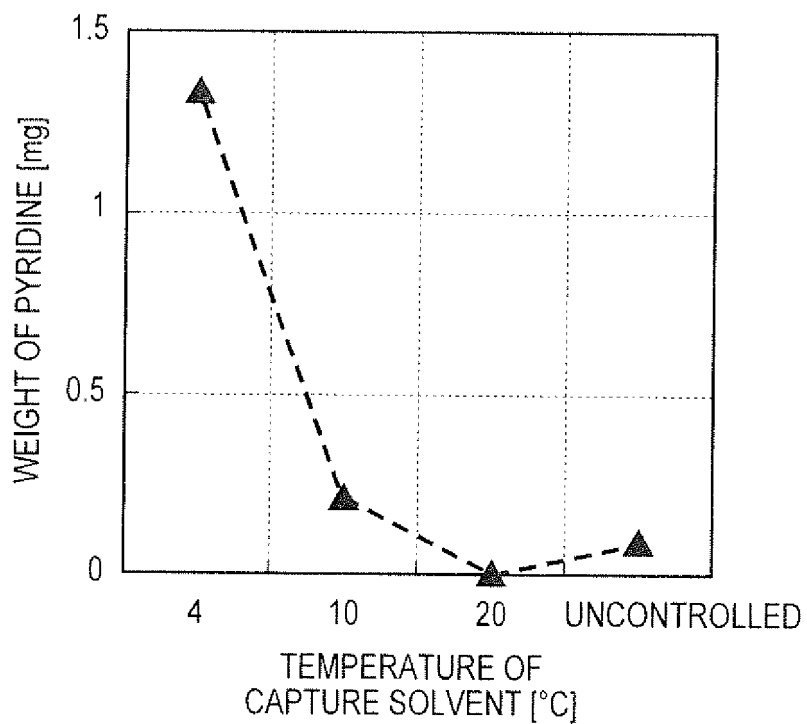

FIG. 13



INTERNATIONAL SEARCH REPORT

International application No.

PCT/JP2015/079053

5	A. CLASSIFICATION OF SUBJECT MATTER A24B15/26(2006.01) i	
	According to International Patent Classification (IPC) or to both national classification and IPC	
10	B. FIELDS SEARCHED Minimum documentation searched (classification system followed by classification symbols) A24B15/26	
15	Documentation searched other than minimum documentation to the extent that such documents are included in the fields searched Jitsuyo Shinan Koho 1922-1996 Jitsuyo Shinan Toroku Koho 1996-2015 Kokai Jitsuyo Shinan Koho 1971-2015 Toroku Jitsuyo Shinan Koho 1994-2015	
	Electronic data base consulted during the international search (name of data base and, where practicable, search terms used)	
20	C. DOCUMENTS CONSIDERED TO BE RELEVANT	
	Category*	Citation of document, with indication, where appropriate, of the relevant passages
25	X	JP 2-238873 A (R.J. Reynolds Tobacco Co.), 21 September 1990 (21.09.1990), page 3, lower right column to page 7, upper left column; page 8; pages 11 to 13 & US 5038802 A column 4, line 10 to column 6, line 40; columns 7, 8, 11 to 15 & US 5016654 A & EP 374779 A2
30	Y	JP 2002-520005 A (Novozymes A/S), 09 July 2002 (09.07.2002), paragraphs [0018] to [0020], [0022] & JP 2011-10656 A & JP 2014-57603 A & US 6298859 B1 column 3, line 61 to column 4, line 58 & WO 2000/002464 A1
35	Y	JP 2002-520005 A (Novozymes A/S), 09 July 2002 (09.07.2002), paragraphs [0018] to [0020], [0022] & JP 2011-10656 A & JP 2014-57603 A & US 6298859 B1 column 3, line 61 to column 4, line 58 & WO 2000/002464 A1
40	<input checked="" type="checkbox"/> Further documents are listed in the continuation of Box C. <input type="checkbox"/> See patent family annex.	
45	* Special categories of cited documents: "A" document defining the general state of the art which is not considered to be of particular relevance "E" earlier application or patent but published on or after the international filing date "L" document which may throw doubts on priority claim(s) or which is cited to establish the publication date of another citation or other special reason (as specified) "O" document referring to an oral disclosure, use, exhibition or other means "P" document published prior to the international filing date but later than the priority date claimed	"T" later document published after the international filing date or priority date and not in conflict with the application but cited to understand the principle or theory underlying the invention "X" document of particular relevance; the claimed invention cannot be considered novel or cannot be considered to involve an inventive step when the document is taken alone "Y" document of particular relevance; the claimed invention cannot be considered to involve an inventive step when the document is combined with one or more other such documents, such combination being obvious to a person skilled in the art "&" document member of the same patent family
50	Date of the actual completion of the international search 17 December 2015 (17.12.15)	Date of mailing of the international search report 28 December 2015 (28.12.15)
55	Name and mailing address of the ISA/ Japan Patent Office 3-4-3, Kasumigaseki, Chiyoda-ku, Tokyo 100-8915, Japan	Authorized officer Telephone No.

Form PCT/ISA/210 (second sheet) (July 2009)

INTERNATIONAL SEARCH REPORT

International application No.

PCT/JP2015/079053

C (Continuation). DOCUMENTS CONSIDERED TO BE RELEVANT

Category*	Citation of document, with indication, where appropriate, of the relevant passages	Relevant to claim No.
Y	JP 2872408 B2 (Imasco Ltd.), 17 March 1999 (17.03.1999), column 5, line 33 to column 6, line 24 & JP 7-505521 A & US 5311886 A column 2, line 59 to column 3, line 35 & US 5601097 A & WO 1993/012675 A2	9, 10, 13
Y	JP 2-49572 A (R.J. Reynolds Tobacco Co.), 19 February 1990 (19.02.1990), claims 17 to 45 & US 5435325 A claims 17 to 45 & EP 338831 A2	9, 10, 13
A	JP 3-10667 A (R.J. Reynolds Tobacco Co.), 18 January 1991 (18.01.1991), entire text; all drawings & US 4941484 A entire text; all drawings & EP 408175 A2	1-14
A	JP 5-7485 A (R.J. Reynolds Tobacco Co.), 19 January 1993 (19.01.1993), entire text; all drawings & US 5065775 A entire text; all drawings & US 5131414 A & US 5234008 A & EP 443761 A1	1-14
A	JP 1-235571 A (R.J. Reynolds Tobacco Co.), 20 September 1989 (20.09.1989), entire text; all drawings & US 5005593 A entire text; all drawings & EP 326370 A2	1-14
A	JP 2006-180715 A (Japan Tobacco Inc.), 13 July 2006 (13.07.2006), paragraph [0014] (Family: none)	1-14
A	JP 2011-522558 A (British American Tobacco (Investments) Ltd.), 04 August 2011 (04.08.2011), entire text; all drawings & US 2011/0155152 A1 entire text; all drawings & WO 2009/150444 A1	1-14

Form PCT/ISA/210 (continuation of second sheet) (July 2009)

REFERENCES CITED IN THE DESCRIPTION

This list of references cited by the applicant is for the reader's convenience only. It does not form part of the European patent document. Even though great care has been taken in compiling the references, errors or omissions cannot be excluded and the EPO disclaims all liability in this regard.

Patent documents cited in the description

- US 4215706 A [0004]
- JP 2009502160 A [0004]
- US 5235992 A [0004]
- JP 5196673 B [0099] [0107]
- JP 5385418 B [0099] [0107]