

(19)



(11)

EP 3 211 728 B1

(12)

EUROPEAN PATENT SPECIFICATION

(45) Date of publication and mention of the grant of the patent:
28.10.2020 Bulletin 2020/44

(51) Int Cl.:
H01R 13/627^(2006.01) H01R 13/635^(2006.01)

(21) Application number: **17155345.6**

(22) Date of filing: **09.02.2017**

(54) ELECTRICAL CONNECTOR SYSTEM COMPRISING A LOCKING ASSURANCE DEVICE

ELEKTRISCHES VERBINDERSYSTEM MIT EINER VERRIEGELUNGSSICHERUNGSVORRICHTUNG

SYSTÈME DE CONNECTEUR ÉLECTRIQUE COMPRENANT UN DISPOSITIF DE SÉCURISATION DE VERROUILLAGE

(84) Designated Contracting States:
AL AT BE BG CH CY CZ DE DK EE ES FI FR GB GR HR HU IE IS IT LI LT LU LV MC MK MT NL NO PL PT RO RS SE SI SK SM TR

- **ROUILLARD, Xavier**
95130 Franconville (FR)
- **JODON DE VILLEROCHÉ, François**
78170 La Celle St Cloud (FR)
- **LORD, Steven**
95160 Eragny Sur Oise (FR)

(30) Priority: **26.02.2016 FR 1651634**

(43) Date of publication of application:
30.08.2017 Bulletin 2017/35

(74) Representative: **Grünecker Patent- und Rechtsanwälte PartG mbB Leopoldstraße 4 80802 München (DE)**

(73) Proprietor: **Tyco Electronics France SAS 95300 Pontoise (FR)**

(72) Inventors:
• **SEBAOUNI, Marc 77270 Villeparisis (FR)**

(56) References cited:
EP-A1- 1 744 408 EP-A1- 2 916 396
FR-A1- 3 008 833 US-A- 5 930 426
US-A1- 2004 102 075

EP 3 211 728 B1

Note: Within nine months of the publication of the mention of the grant of the European patent in the European Patent Bulletin, any person may give notice to the European Patent Office of opposition to that patent, in accordance with the Implementing Regulations. Notice of opposition shall not be deemed to have been filed until the opposition fee has been paid. (Art. 99(1) European Patent Convention).

Description

[0001] The present invention relates to the field of automotive electrical connectivity. It relates particularly to an electrical connector system comprising two mating connector housings and a locking assurance device, in particular to a spring locking assurance device.

[0002] The repeated high intensity vibrations and/or shocks to which the diverse electrical elements in motor vehicles can be subjected, typically electrical connector systems comprising a female connector holder with one or more electrical contacts and a mating male tab holder comprising one or more electrical contact tabs, can lead to uncoupling between the female connector holder and the male tab holder, and therefore to poor electrical contact or even interruption of the electrical contact.

[0003] To counter this problem, it is known conventionally to use male tab holders similar to the male tab holder 400 illustrated in FIGS. 4A-4B, comprising at least one locking lug such as the locking lug 402 allowing, by means of an adapted locking lance of the mating female connector holder, the locking of the electrical connector system when the female connector holder and the male tab holder 400 are in a fully coupled state, that is to say, fully inserted one inside the other, and when the physical and electrical contacts are assured in an appropriate manner. As illustrated in FIGS. 4A-4B, such a locking lug 402 is generally presented in the form of a protrusion of the male tab holder 400, one surface 406 of which is essentially perpendicular to the direction of the coupling movement, acts as a stop for the head of the locking lance of the female connector holder in a fully coupled state in order to achieve the said locking in the coupled state of the connector system by preventing movement counter to the insertion movement.

[0004] Still with reference to FIGS. 4A-4B for clarity, in order to prevent the connector systems from being incorrectly fitted, in other words to prevent the female connector holder and male tab holder 400 from being incorrectly coupled, it is known, firstly, to prevent locking by forming a stop on a thrust surface provided at the end of a lance of a locking assurance device of the female connector holder on the edges 404 of the opening 403 of the male tab holder 400 in which the electrical contact tabs are located and which faces the female connector holder during a coupling movement. Thus, if the force exerted on the female connector holder and/or the male tab holder 400 is not sufficient during the coupling movement, the thrust surface of the locking assurance device of the female connector holder remains abutted against the edges 404 of the male tab holder 400, preventing locking.

[0005] However, if the force exerted on the female connector holder and/or the male tab holder 400 during the coupling movement is sufficient, the lance of the locking assurance device of the female connector holder terminating with the thrust surface is deflected with respect to the edges 404 of the opening of the male tab holder 400. Conventionally, it is also known that the locking lug 402

of the male tab holder 400 presents a sloping rib 405, essentially following the direction of the coupling movement, thus allowing the lance of the locking assurance device of the female connector holder to be deflected and guided such that it passes above the locking lug 402, thereby allowing the coupling movement up to the correctly coupled state of the connector system, in which the lance of the locking assurance device then bypasses the locking lug 402, falls back to its non-deflected position and is then in a position abutting against the locking lug 402, in particular the corresponding stop or locking surface 406 of the locking lug 402, thereby effecting the said locking of the connector system, preventing a movement counter to the coupling movement.

[0006] Additionally, it is also known from the prior art to use a spring locking assurance device comprising a locking lance and at least one spring, the locking assurance device being configured for being movably accommodated, in particular in a sliding manner, in the female connector holder. Conventionally, such a locking assurance device is arranged such that the said spring is relaxed when the female connector holder and the male tab holder are in the uncoupled state, and compressed or "loaded" when they are in a partially coupled state. In such systems, the compression of the spring is opposed to the coupling movement, such that the force exerted on the female connector holder and/or male tab holder during the coupling movement is not sufficient to bypass the stop between the locking lance and the edges of the male tab holder, the spring then automatically pushes back the female connector holder with respect to the male tab holder in a movement counter to the coupling movement. An incorrectly or partially coupled assembly of the connector is thus prevented. However, if the force exerted on the female connector holder and/or male tab holder during the coupling movement is sufficient, the locking lance can then be deviated with respect to the edges of the male tab holder and then deviated and guided by means of the rib to bypass the locking lug and then effect the locking as described above. When the electrical connector system is in the locking state, an inadvertent and/or unintentional disconnection due to shocks or vibrations in the environment is in principle no longer possible. Only a deliberate manual disconnection on the part of an operator is then possible.

[0007] Such systems nevertheless present the disadvantage that, once the system is in the locking state, during a manual disconnection operation therefore necessitating the unlocking of the system, for example for maintenance purposes, the locking lance of the locking assurance device limits the retention force and risks breakage. In fact, for manual disconnection it is necessary to deflect the locking lance manually and to maintain it, still manually, in a deflected state in order to allow disconnection of the male tab holder mated into the female connector holder, entailing a breakage risk if the operator applies excessive pressure to the locking lance. Furthermore, this operation is inconvenient by reason of the size

of the connectors and the arrangement of the locking lance.

[0008] In document US 2004/102075 A1 the slider is mounted on the upper surface of the outer tube of the female housing. Two slider operating stepped portions are provided at the opposite side surfaces of the rear end of the slider and the operating portions bulge out side-ways to a larger degree towards the back so that the slider can be pulled back from the front.

[0009] Document FR3008833 A1 discloses an electrical connector system comprising a locking assurance device and a first connector housing configured for being engageable with a second mating connector housing that is capable to be locked therewith in accordance with the preamble of independent claim 1.

[0010] One objective of the present invention is therefore to provide a system allowing not only improved locking of an electrical connector system comprising a female connector holder having a locking assurance device and a mating male tab holder, but also facilitated operation of the unlocking of the system.

[0011] According to one aspect of the present invention, the objective is achieved by means an electrical connector system comprising a locking assurance device and a first connector housing configured for mating with a second mating connector housing that can be locked therewith, wherein the locking assurance device comprises at least one spring and is configured for being movably accommodated in the first housing such that a displacement of the locking assurance device in the first housing from a delivery position causes a loading of the said at least one spring. The electrical connector system comprising a locking assurance device is further configured such that, during an action of mating the second housing into the first housing, the locking assurance device is displaced from the delivery position by the second housing such that the loading of the said at least one spring opposes the mating as long as the electrical connector system is not in a locked state wherein the second housing is locked with the first housing, and the locking assurance device is not returned to the delivery position. The locking assurance device further comprises a body configured for being movably accommodated, in particular in a sliding manner, in the first housing in a mating direction of a second housing into the first housing and the first housing further comprises a body comprising an accommodation portion which is a recess of geometry adapted to that of the locking assurance device. According to this aspect of the invention, the locking assurance device is further configured such that, in the locking state, a displacement of the locking assurance device from the delivery position causes a loading of the said at least one spring authorising the unlocking of the first and second housings.

[0012] In an electrical connector system having a spring locking assurance device, it is therefore possible to use a pressure of the second housing, for example a male tab holder, in order to push the mobile, in particular

slidable, locking assurance device accommodated in the first housing, for example a female connector holder, thereby loading the spring or springs. In this way, the loading of the spring or springs opposes the mating of the second housing into the first housing, such that if the user does not push the second housing sufficiently into the first housing, the second housing is ejected automatically. In other words, the locking spring of the locking assurance device assures automatic ejection and prevents an incorrect physical and/or electrical connection of the electrical connector system.

[0013] In a locking state, that is to say, when the first and second connector housings are correctly mated and locked together, and the locking assurance device is returned to its position and in particular its delivery state, thereby assuring maintenance of the locking and connection of the system, a manual pressure applied by an operator to the locking assurance device again causes a loading of the spring or springs which helps, in a single movement, to unlock the first and second housings. This unlocking is only possible if the locking assurance device is manually pushed sufficiently. If not, the locking assurance device is returned to its delivery position by reason of the loading of the spring or springs which once again opposes a pressure applied to the locking assurance device. A disconnection is therefore prevented automatically if the user does not sufficiently load the spring or springs so as to allow unlocking. If the user pushes the locking assurance device so as to load the spring or springs sufficiently, unlocking may be authorized without the use of special tools and without having manually to access the locking lance of the female connector holder and/or the locking assurance device, thereby preventing any breakage resulting from a mal-operation on the part of the operator.

[0014] According to variants of this aspect of the present invention, and without limitation: The locking assurance device being configured for being movably accommodated, in particular in a sliding manner, in the first housing in a mating direction of a second housing into the first housing, it is therefore possible to arrange the locking assurance device so that the mating of the second housing into the first housing in a predetermined mating direction loads the said at least one spring of the locking assurance device such that the relaxation of the spring or springs is also in the mating direction. The locking assurance device can therefore be configured advantageously so that the ejection of the second housing in the event of an incorrect connection takes place as directly as possible, namely in the mating direction.

[0015] Advantageously, the loading of the said at least one spring authorizing the transition to the locking state and/or the unlocking from the locking state can be a maximum relative loading of the said at least one spring. This configuration is preferable so that only a state of maximum relative loading of the spring or springs of the locking assurance device authorizes the transition to the locked state and/or authorizes unlocking. In other words,

the locking assurance device can be configured advantageously so that, during a mating action, the second housing is ejected automatically if the predetermined loading of the spring is not achieved. Furthermore, the locking assurance device can also be configured advantageously so that, during a manual unlocking on the part of an operator, unlocking is only authorized when the predetermined loading of the spring is achieved.

[0016] Advantageously, the loading of the said at least one spring authorizing transition to the locked state can be substantially the same as the loading authorizing unlocking. This configuration advantageously allows the use of the same predetermined loading of the spring or springs to authorise the mating and locking of the second housing in the first housing, but also to authorize manual unlocking where necessary.

[0017] Preferably, the locking assurance device can further comprise at least one thrust surface configured such that, during a mating action, a thrust applied thereto, in particular by the second housing, causes the loading of the said at least one spring opposing the mating action. As mentioned above, the locking assurance device can be configured advantageously to allow a direct interaction with the second housing. An alternative form of configuration with in particular two thrust surfaces has proven advantageous, but configurations with one, three or more thrust surfaces can also be envisaged in the context of the present invention.

[0018] Advantageously, the locking assurance device can further comprise an unlocking thrust surface, in particular distinct from the said at least one thrust surface of the preceding variant, configured such that, in the locking state, a thrust thereon causes the loading of the said at least one spring authorizing an unlocking. In order to prevent an unintentional disconnection, the locking assurance device can be provided with a thrust surface specifically dedicated to unlocking. Such a surface can then be arranged preferably so as not to be able to come into contact with the second housing such that, starting from a locking state of the system, it is necessary to push this unlocking thrust surface manually in order to cause the loading of the spring necessary for authorization of the unlocking of the system.

[0019] Advantageously, the locking assurance device can further comprise at least one guide surface, and the locking assurance device can further be configured such that, during a displacement of the locking assurance device from the delivery position, the said at least one guide surface causes a displacement of a first locking element of the first housing authorizing transition to the locking state and/or authorizing unlocking from the locking state. It is therefore possible to configure the locking assurance device such that a displacement thereof causing the loading of the spring or springs also causes, where necessary, a deflection of a locking element of the first housing, for example a locking lance, so as to allow the passage of a corresponding locking element of the second housing in either direction of the mating movement.

[0020] According to another aspect of the present invention, the objective is also achieved by means of an electrical connector system comprising a locking assurance device according to the preceding aspect, or any variant thereof, and a first connector housing configured for mating with a second mating connector housing capable of being locked therewith, wherein the locking assurance device is movably accommodated in the first housing, in particular in a sliding manner, in a mating direction of the second housing into the first housing. The first housing comprises a first locking element capable of being displaced, in particular resiliently, from a delivery position in which, in a locking state, the first locking element is locked with a second locking element of a second mating housing. According to this aspect, the electrical connector system is further configured such that a loading of the said at least one spring causes a displacement of the first locking element of the first housing authorizing transition to the locking state and/or unlocking from the locking state.

[0021] The system therefore incorporates all the advantages of the locking assurance device and its variants. Furthermore, according to the variants of this other aspect of the present invention, and without limitation:

In a combination with a locking assurance device comprising a thrust surface configured such that, during a mating action, a thrust exerted thereon causes the loading of the at least one spring opposing the mating action, the electrical connector system can be further configured such that, in the locking state, the said at least one thrust surface is arranged such that a thrust thereon is not permitted, in particular by the second housing. It is therefore possible to configure the locking assurance device with a judicious arrangement of the thrust surface against which the second housing comes to abut and exerts a pressure during the mating action, such that, once the locking state is achieved, the second housing cannot advance further into the first housing such that a repeated thrust on the locking assurance device is not permitted, thereby preventing any unintentional disconnection.

[0022] Preferably, the locking assurance device can be further configured such that, in the locking state, the unlocking thrust surface is arranged out of reach of the second housing. It is therefore possible to prevent an unintentional disconnection by conveniently arranging the unlocking thrust surface so that an interaction between the said surface and the second housing is not possible. Thus, a manual intervention on the part of an operator on the unlocking thrust surface is necessary in order to unlock the system.

[0023] Generally, by means of the diverse aspects described above, whether they are taken independently of one another or in combination, the present invention brings about an improvement in locking and, where applicable, assurance of the locking between a female connector holder and a male tab holder of an electrical connector system compared with the connectors known in the prior art. Furthermore, the present invention also

brings about an improvement in the unlocking and then the disconnection of the locked system and prevents in particular breakage or twisting of the locking elements.

[0024] The invention will be explained in greater detail below by means of advantageous embodiments and by reference to the following accompanying figures, wherein:

FIGS. 1A-1B illustrate schematically an example of an embodiment of a locking assurance device according to one aspect of the present invention, in two three-dimensional views;

FIG. 2 illustrates schematically a female connector holder housing in an example embodiment of a first housing of an electrical connector system according to one aspect of the present invention, in a three-dimensional view;

FIG. 3 illustrates schematically an assembled female connector holder, wherein the locking assurance device illustrated in FIGS. 1A-1B is accommodated in the housing illustrated in FIG. 2 in an example embodiment of an electrical connector system according to one aspect of the present invention, in a three-dimensional view;

FIGS. 4A-4B illustrate schematically an example male tab holder, in two three-dimensional views;

FIGS. 5A-5B illustrate schematically an example embodiment of an electrical connector system comprising the locking assurance device accommodated in the assembled female connector holder housing as illustrated in FIG. 3 and the male tab holder illustrated in FIGS. 4A-4B, prior to coupling, in a three-dimensional view (FIG. 5A) and in a sectional view (FIG. 5B), according to one aspect of the present invention;

FIGS. 6A-6D illustrate schematically successive steps in the coupling and locking of the electrical connector system illustrated in FIGS. 5A-5B in an uncoupled state (FIG. 6A), in a partially coupled state (FIG. 6B), in another partially coupled state (FIG. 6C), and in a coupled and locking state (FIG. 6D); and

FIGS. 7A-7C illustrate schematically successive stages in the unlocking of the electrical

connector system from the locking state illustrated in FIG. 6D.

[0025] In the following description, a same element incorporated in several figures may be designated by the same reference sign. The description of an element previously illustrated in a figure may be omitted in the description of other figures; the reader can refer to the previous description for further details.

[0026] FIGS. 1A-1B are three-dimensional views illustrating an example embodiment of a locking assurance device 100 according to one aspect of the present invention, wherein FIG. 1A represents the device 100 in a perspective view from above, and FIG. 1B represents the device 100 in a perspective view from below.

[0027] Thus, as shown in FIGS. 1A-1B, the locking assurance device 100 comprises a body 101, configured and intended to be accommodated in an adapted accommodation portion of a female connector holder housing for an electrical connector system, connected to at least one lance, here the two lances 102, 103, intended in particular to assure the locking of the electrical connector system comprising a female connector holder and a male tab holder coupled together. As illustrated in particular in FIG. 1A, in a delivery state, the lances 102, 103 can extend substantially parallel to the body 101, but other configurations may be envisaged.

[0028] The body 101 of the locking assurance device 100 can have a geometry that is preferably adapted to that of a mating accommodation portion on a female connector holder housing in which the device 100 is intended to be movably accommodated, in particular in a sliding manner. In the example of the embodiment of FIGS. 1A-1B, the body 101 comprises two arms 106, 107 with a substantially tubular geometry, configured for insertion into an adapted accommodation portion of a female connector holder. As illustrated in the view of FIG. 1A, each arm 106, 107 comprises a locking lug 108, 109 respectively which is configured for locking the device 100 with a female connector holder housing. It is however possible, in variants, to provide the device 100 with a single arm or alternatively with more than two arms. It is also possible, in certain variants, to have more than one lug on an arm allowing locking with an adapted female connector holder. The view from below of FIG. 1B further illustrates that each arm 106, 107 comprises a corresponding cavity 110, 111.

[0029] According to this aspect of the invention, the locking assurance device 100 comprises at least one spring (not represented), in particular as many springs as there are arms 106, 107 accommodated in the respective corresponding cavity 110, 111 in order to perform a spring locking function between a female connector holder and a male tab holder in an electrical connector system. Thus, the locking assurance device 100 of the example embodiment illustrated in FIGS. 1A-1B could comprise a single spring accommodated in one of the two cavities 110 or 111, or alternatively could comprise two

springs, accommodated in cavity 110 and in cavity 111 respectively. An example locking mechanism with two springs will be detailed below.

[0030] FIG. 1A further illustrates that the body 101 can comprise at one end a head 105 forming an angle, for example "L" or "T" shaped, and presenting an end surface 112. As will be detailed below, the surface 112 can be configured as an unlocking thrust surface for a manual action on the part of an operator. Furthermore, one end of each lance 102, 103 can present an end surface 113, 117 respectively capable of having an indentation presenting another end surface 114, 118. In this embodiment the respective surfaces 114, 118 of the two lances 102, 103 can have stop surfaces configured to effect a stop with the edges of the opening of a male tab holder during the coupling of the female connector holder and the male tab holder, preventing the continuation of the coupling movement if the force exerted on the female connector holder and/or the male tab holder is not sufficient to compress the springs to a predetermined loading authorizing the continuation of the coupling movement, as will be detailed below. In the presently illustrated embodiment, the locking assurance device 100 thus comprises at least one stop or thrust surface 114, 118 and in particular two such surfaces. As mentioned above, it can nevertheless be envisaged that the locking assurance device 100 only comprises one such surface (and therefore a single lance) or alternatively three or more such surfaces (and therefore the same number of respective lances). FIGS. 1A-1B further illustrate that each lance 102, 103 can further terminate substantially in an "L" shape by means of a lug 119, 120 respectively which can be shoe shaped. As shown in FIG. 1B, the bottom of the locking assurance device 100 can comprise an element 115 presenting an inclined surface 116 which, as will be detailed below, can be a guide or unlocking surface. Thus, during coupling between a female connector holder and a male tab holder, if the force exerted is sufficient for the female connector holder and the male tab holder to be in a coupled state, the at least one stop surface 114, 118 can prevent a movement counter to the coupling by effecting a stop against the edges of the opening of the male tab holder.

[0031] Other characteristics and functionalities of the locking assurance device 100, or more generally of this aspect of the present invention and its diverse variants, will be explained below.

[0032] FIG. 2 is a three-dimensional view illustrating an example embodiment of a female connector holder housing 200 of an electrical connector system according to one aspect of the present invention. In this example, the female connector holder housing 200 comprises a body 201 with an upper part 202 adapted for accommodating a locking assurance device, and a lower part 203 adapted for accommodating one or more electrical contacts. In the example illustrated in FIG. 2, but without limitation, the upper part 202 is adapted for accommodating the locking assurance device 100 of the example

embodiment illustrated in FIGS. 1A-1B.

[0033] Thus, as shown in FIG. 2, the upper part 202 of the body 201 of the female connector holder housing 200 comprises an accommodation portion 204 which is a recess of geometry adapted, and in particular complementary, to that of the locking assurance device 100. The accommodation portion 204 can then comprise two grooves 205, 206 on either side, the geometry of which is adapted, and is in particular complementary, to that of the arms 106, 107 of the locking assurance device 100, and which substantially form hollow channels into which the arms 106, 107 can be introduced so as to accommodate the locking assurance device 100 in the accommodation portion 204. The grooves 205, 206 can each further comprise an end wall 207, 208 allowing the locking assurance device 100 accommodated in the accommodation portion 204 to be prevented from moving out of it by means of an abutment of the lugs 108, 109 against the said end walls 207, 208 during a movement counter to the insertion of the device 100 into the accommodation portion 204. Thus, in their relaxed state, the springs (not represented) allow the lugs 108, 109 to be brought back to abut against the end walls 207, 208.

[0034] Furthermore, in the variant illustrated in FIG. 2, the accommodation portion 204 comprises a locking lance 209 configured for effecting a locking of the female connector holder 200 with the locking lug of a mating male tab holder. As also shown in FIG. 2, the lance 209 comprises an indentation at its end forming an unlocking surface 210 against which the unlocking surface 116 of the locking assurance device 100 accommodated in the accommodation portion 204 effects a thrust when a pressure is exerted thereon causing a loading of the springs. This aspect will also be illustrated below.

[0035] FIG. 2 further illustrates that the lower part 203 of the body 201 of the female connector holder 200 comprises an accommodation portion 211 intended to accommodate one or more electrical contacts or more generally electrical contact housings, as illustrated for example by assembly 300 of FIG. 3 and the example embodiments detailed below. The housing 211 is also configured for receiving a mating male tab holder which, in a fully coupled state with the female connector holder 200, can be pushed in as far as the stop wall 218 of the accommodation portion 211.

[0036] FIG. 3 is a three-dimensional view illustrating an example embodiment of an assembled female connector holder 300 according to one aspect of the present invention, wherein the locking assurance device 100 of the example embodiment illustrated in FIGS. 1A-1B is movably accommodated, in particular in a sliding manner, in the accommodation portion 204 of the female connector holder housing 200 of the example embodiment illustrated in FIG. 2. The reader is therefore referred to the previous description for further details concerning these two elements.

[0037] As illustrated in FIG. 3, in this example embodiment of an assembled female connector holder 300, the

locking assurance device 100 is movably accommodated, substantially in translation, in the accommodation portion 204 of the upper part 202 of the female connector holder 200 such that the arms 106, 107 of the lance 100 are accommodated in a groove 205, 206 respectively. The locking assurance device 100 is illustrated here in the delivery position. The tabs 108, 109 therefore substantially abut against the inside of the walls 207, 208 and the locking springs are in a relaxed state or in a relative state of minimum compression (not visible in FIG. 3) and are accommodated in the cavities 110, 111 of the arms 106, 107.

[0038] In the three-dimensional view of FIG. 3, the assembled female connector holder 300 is represented in a front three-quarter view. It is thus clear that the lance 102 of the locking assurance device 100 presents its end surfaces 113, 114 so as to face a mating male tab holder which would engage in the assembled female connector holder 300 in a corresponding electrical connector system. The lance 103 is not visible or is only just visible, but a person skilled in the art will readily understand that its end surfaces 117, 118 are arranged in a manner similar to those of the lance 102. In particular, the stop surfaces or thrust surfaces 114, 118, which will first come to abut against the edges of the opening of a mating male tab holder, are also visible in this view.

[0039] FIG. 3 further illustrates that an electrical contact housing 301 is accommodated in the accommodation portion 211 of the lower part 203 of the body 201 of the female connector holder 200, in particular by means of a seal 304. In this example of a possible embodiment of this aspect of the present invention, and without limitation for the present invention, the electrical contact housing 301 comprises two electrical contact terminals 302, 303 configured for receiving mating electrical contact tabs of a male tab holder mating with the assembled female connector holder 300. In some variants, the electrical contact housing 301 could comprise only one electrical contact terminal. In alternative variants, the electrical contact housing 301 could comprise more than two electrical contact terminals, for example three terminals or more. As a result, a mating male tab holder will have as many electrical contact tabs as there are electrical contact terminals 302, 303 in the electrical contact housing 301.

[0040] FIGS. 4A-4B are three-dimensional views illustrating an example male tab holder 400 for an electrical connector system such as that described above. FIG. 4A represents the male tab holder 400 in a "front-on" view, while FIG. 4B shows it in a "rear" view.

[0041] As mentioned above, the male tab holder 400 can be a conventional male tab holder. It therefore comprises a substantially hollow longitudinal body 401, in which one or more electrical contact tabs (not represented) can be accommodated. The rear view of FIG. 4B illustrates the case of a tab holder comprising two orifices 407, 408 allowing the entry of cables or more generally electrical conductors, the terminations of which are elec-

trical contact tabs. In this case, the male tab holder 400 can therefore have two electrical contact tabs which can be mated to the electrical contact terminals 302, 303 of the assembled female connector holder 300 of the example embodiment illustrated in FIG. 3.

[0042] As shown in particular in FIG. 4A, the male tab holder 400 also comprises an orifice or an opening 401. As will become evident below, the accommodation portion 211 of the female connector holder housing 200 of the assembled female connector holder 300 is therefore dimensioned for receiving the mating male tab holder 400 in order to make an electrical contact between the tabs of the male tab holder 400 and the electrical contact terminals 302, 303 of the female connector holder 300 assembly. As will be detailed below, during a mating operation of such a male tab holder 400 into the mating assembled female connector holder 300, the edges or perimeter 404 of the opening 403 of the male tab holder 400 will in particular come to abut against the surface 114 of the locking assurance device 100, thus exerting a pressure thereon and loading the springs.

[0043] As shown in FIGS. 4A-4B, in order to effect locking with a mating female connector holder, the male tab holder 400 further comprises a locking lug 402 on the external surface of the body 401, which can be substantially "T" shaped, protruding from the body 401 and slightly set back from the edges 404 of the coupling opening 403. As also illustrated in FIGS. 4A-4B, the locking lug 402 comprises a rib 405 which is substantially parallel to the longitudinal direction of the body 401 or generally to a direction of coupling or mating between the male tab holder 400 and a mating female connector holder such as the female connector holder 300, in a rising gradient in a direction substantially running from the edge 404 of the opening 403 to the end of the male tab holder 400 presenting the two orifices 407, 408. The locking tab 402 further comprises, on the side opposite to the rib 405, a locking surface 406, visible in particular in FIG. 4B. This surface 406 can therefore be hooked by the locking lance 209 of the female connector holder housing 200 in the locking state of the system.

[0044] FIGS. 5A-5B illustrate an example embodiment of an electrical connector system 500 according to one aspect of the present invention, comprising the assembled female connector holder 300 of the example embodiment illustrated in FIG. 3 with in particular the locking assurance device 100 accommodated in the female connector holder 200, and the male tab holder 400 illustrated in FIGS. 4A-4B, prior to coupling, in a three-dimensional view (FIG. 5A) and in a cross-section (FIG. 5B). Such a system 500 can for example be used for electrical connection in an automotive motor vehicle, without however being restricted solely to such a use.

[0045] In FIGS. 5A-5B, the electrical connector system 500 is in an uncoupled state, that is to say, unlocked. In particular, the female connector holder 300 and the male tab holder 400 are facing each other for coupling, but are not yet in physical contact. In particular, the surfaces 114,

118 of the lances 102, 103 of the locking assurance device 100 are not abutted against the edges 404 of the opening 403 of the male tab holder 400. More particularly, there is no electrical contact between the electrical contact terminals 302, 303 and the electrical contact tabs (not represented) of the male tab holder 400. In other words, the female connector holder housing 200 or the assembled female connector holder 300 and the male tab holder 400 forming the first and second housings, are in an uncoupled state. Furthermore, the two locking springs (not represented) of the locking assurance device 100 are relaxed, that is, at rest. Thus, the surfaces 108, 109 of the lances 106, 107 of the locking assurance device 100 are not abutted against the edges 207, 208 of the female connector holder housing 200.

[0046] Hereinafter, it will be evident for a person skilled in the art that substantially one half of the elements of the system 500 are visible in the view along the cross-section of FIG. 5B and in the successive views of FIGS. 6A-6D and 7A-7C, which are sections in the same plane as the section of FIG. 5B. As a result, it will also be evident for a person skilled in the art that the elements not illustrated in these sections behave in a manner similar to the illustrated elements which are substantially symmetrical to them.

[0047] FIGS. 6A-6D illustrate schematically successive stages in the coupling of the electrical connector system 500 represented in FIGS. 5A-5B by a plurality of section views, starting with an uncoupled state represented in FIG. 6A and culminating in a locking state represented in FIG. 6D in which the housings 300, 400 of the electrical connector 500 are fully coupled and locked, passing through two successive partially coupled states represented in FIG. 6B and 6C. The cross-sections of FIGS. 6A-6D are substantially in line with the view of FIG. 5B.

[0048] As shown in FIG. 6A, and in particular the circled part, at the first physical contact between the male tab holder 400 and the female connector holder 300 in view of a coupling of the electrical connector system 500, the upper part of the edge 404 of the opening 403 of the male tab holder 400 comes to abut against the said at least one stop surface 114, 118 formed by the recess under the end surface 113, 117 of the corresponding lance 102, 103 of the locking assurance device 100. A deflection of the head of the locking lance 209 of the female connector holder housing 200 and a deflection of the lances 102, 103 of the locking assurance device 100 are mutually precluded. The locking springs accommodated in the cavities 110, 111 of the arms 106, 107 of the device 100, which is in its delivery position, are substantially relaxed. At this stage, there is no electrical contact as the male tab holder 400 is not yet mated into the housing 200 of the female connector holder 300. The connector system 500, and therefore the assembly of the female connector holder 300 and male tab holder 400, is in an uncoupled state, and there is no locking between the locking lance 209 and the locking lug 402. In order to affect a mating

of the male tab holder 400 into the female connector holder 300, it is necessary to further insert the male tab holder 400 in the direction indicated by the arrow on FIG. 6A.

[0049] FIG. 6B illustrates a later coupling stage during which a force is exerted on the female connector holder 300 assembly and/or on the male tab holder 400 intended to continue the coupling of the electrical connector system 500 in the mating direction indicated by the arrow illustrated previously in FIG. 6A. This force is not, however, sufficient to complete the coupling. Thus, as shown in FIG. 6B, the locking assurance device 100 is subject to a thrust strain and advances further into the accommodation portion 204 of the housing 200 of the female connector holder 300. In particular, a thrust is exerted by the edge 404 of the opening 403 of the male tab holder 400 on the thrust surfaces 114, 118. As a result, at this stage the springs of the locking assurance device 100 are in a loading state but not yet at maximum relative loading or at least not yet at a predetermined relative loading corresponding to authorization for the locking of the system. In other words, as can also be seen in FIG. 6B, the arms 106, 107 have moved back into the respective grooves 205, 206 of the accommodation portion 204 of the female connector holder 200, thus compressing the springs. The system 500, and therefore the female connector holder 300 and male tab holder 400, are in a partially coupled state, but there is no locking between the locking lance 209 and the locking lug 402. However, the head of the locking lance 209 comes into contact with the inclined rib 405 of the locking lug 402 of the male tab holder 400.

[0050] At the stage illustrated in FIG. 6B, there is a start of electrical contact but if the force exerted subsequently in order to continue the movement of coupling of the system 500 is not sufficient, the locking springs will have a tendency to relax, such that the stop surfaces 114, 118 will push back the edge 404, thus ejecting the male tab holder 400 from the female connector holder 300, that is, separating the electrical connector system 500, which will therefore be returned to an uncoupled state, as in FIGS. 5A or 6A. In this way, the invention advantageously brings about an improvement in a spring locking system preventing an incorrect electrical connection between the contact terminals of a female connector holder and the contact tabs of a mating male tab holder.

[0051] FIG. 6C illustrates the case whereby the force exerted on the female connector holder 300 and/or on the male tab holder 400 in the direction of insertion is sufficient to continue the coupling of the electrical connector system 500. The springs of the locking assurance device 100 are now further compressed than at the stage illustrated in FIG. 6B as the device 100 is pushed further back into the accommodation portion 204, so that the unlocking element 115 has deviated the locking lance 209 through the action of its inclined surface 116 on the unlocking surface 210. Furthermore, the head of the lance 209 is also deviated by the inclined rib 405 of the lug 402. As a result, the passage of the locking lug 402

and therefore the forward movement of the male tab holder 400 into the accommodation portion 211 will now be possible.

[0052] As also shown in FIG. 6C, the locking assurance device 100 is again subject to a thrust strain but has reached the stop at the bottom of the accommodation portion 204 of the housing 200 of the female connector holder 300. In other words, the springs of the device 100 are in a state of compression corresponding to a predetermined relative loading which is a maximum relative loading in respect of the states illustrated previously. The female connector holder 300 and the male tab holder 400 of the electrical connector system 500 are therefore on the point of being correctly coupled and locked but are still represented in a partially coupled state. In particular, there is no locking between the locking lance 209 and the locking tab 402. All that is required subsequently is to continue to insert the male tab holder 400 into the accommodation portion 211 in order to complete the coupling action. However, at the stage illustrated in FIG. 6C, if the coupling action is not continued, the action of the springs pushing back the locking assurance device 100 will lower the lances 102, 103 of the device 100, together with the locking lance 109 of the female connector holder 300, thus preventing the insertion of the male tab holder 400 and ejecting it. In this way, the invention advantageously brings about an improvement in a spring locking system preventing an incorrect electrical connection between the contact terminals of a female connector holder and the contact tabs of a mating male tab holder.

[0053] Finally, FIG. 6D illustrates the case where the male tab holder 400 has been correctly mated into the female connector holder 300 and is locked to it. As the circled part details, the head of the locking lance 209 has passed behind the locking lug 402 and therefore prevents the disconnection of the male tab holder 400 by abutting against the surface 406 of the back of the locking lug 402. Furthermore, the locking assurance device 100 has returned to its delivery position, wherein the unlocking element 115 prevents the locking lance 209 from rising again and the lances 102, 103 have returned to their initial position. The springs of the device 100 are therefore in a state of minimum relative loading or compression or are even fully relaxed. In this locking state, there is an electrical contact between the mating electrically conductive elements of the male tab holder 400 and the female connector holder 300.

[0054] Furthermore, as shown in FIG. 6D, at this stage a thrust or pressure exerted on the male tab holder 400 no longer has a direct effect on the locking assurance device 100. In particular, advantageously, the edge 404 of the opening 403 is no longer in a position to interact with the stop surfaces 114, 118, and the male tab holder 400 correctly mated and locked with the female connector holder 300 can no longer compress the springs of the locking assurance device 100. Thus, an unintentional disconnection caused by an additional male tab holder 400 pressure is not possible. The system 500 must be dis-

connected manually. As will be detailed below, in order to disconnect the system starting from the locking state illustrated in FIG. 6D, it is necessary to apply thrust to the unlocking thrust surface 112 of the head 105 of the locking assurance device 100. This is not possible at this stage by applying a pressure to the male tab holder 400, given that the unlocking thrust surface 112 is judiciously arranged beyond the reach of the elements of the male tab holder 400 applying the thrust to the locking assurance device 100.

[0055] FIGS. 7A-7C illustrate successive stages in the unlocking and disconnection of the electrical connector system from the locking state illustrated in FIG. 6D and explained previously.

[0056] As shown in FIG. 7A, in order to unlock the connector system 500, an operator must apply pressure manually to the unlocking thrust surface 112 of the head of the locking assurance device 100 so as to cause it to slide into the accommodation portion 204 of the housing 200 of the female connector holder 300. The springs of the device 100 then return to a loaded state. The circled part on FIG. 7A shows in detail that an operator has applied pressure manually to the surface 112 such that the unlocking surface 116 of the unlocking element 115 is now sufficiently far forward to come into contact with the unlocking surface 210 of the unlocking lance 209 of the housing 200 of the female connector holder 300. However, as also shown in FIG. 7A, the male tab holder 400 is still locked to the female connector holder 300 by means of the locking lance 209, the head of which is still hooking the locking lug 402. As during the mating action illustrated in FIGS. 6A-6D, if the operator does not apply a sufficient thrust to the locking assurance device 100, the spring returns the device 100 to its delivery position, thus automatically assuring a return to the locking state illustrated in FIG. 6D.

[0057] FIG. 7B illustrates the following stage, in which an operator has applied sufficient pressure to the unlocking thrust surface 112 in order to cause the locking assurance device 100 to slide to the bottom of the accommodation portion 204. The springs are therefore in a maximum relative loading state, which authorizes a disconnection of the male tab holder 400. For the unlocking action, this stage is substantially the counterpart of the locking action stage illustrated in FIG. 6C, except that the connector system 500 is still in a mated state. As detailed by the circled part, the unlocking surface 116 is now sufficiently far forward to have deviated the locking lance 209 by sliding under the unlocking surface 210. At this stage, it is still possible to return automatically to the locking state illustrated in FIG. 6D if the operator releases the locking assurance device 100 due to the action of the springs which will automatically return it to the delivery position.

[0058] Finally, FIG. 7C illustrates the disconnection of the male tab holder 400 from the previous step illustrated in FIG. 7B. As again illustrated by the circled part, this is possible because the state of maximum relative loading

of the springs is maintained by the operator continuing to exert a pressure on the locking assurance device 100 so as to maintain it at the same level of advancement into the accommodation portion 204 as the stage illustrated in FIG. 7B. Given that the only action on the part of the operator has been to manually push the head 105 of the locking assurance device 100, the operator has not been required to deflect any locking lance manually, thereby preventing any risk of breakage, in particular of the locking lance 209. In order to achieve the disconnection operation, the operator has therefore been able, in a continuous and simplified movement compared with the system known in the prior art, to use the same loading state of the locking springs and the action of the unlocking surface 116 on the locking lance 209 used in the mating action.

[0059] The diverse aspects of the present invention, in particular the various embodiments and their variants described above, can be taken independently of one another or in combination with one another and have the advantage of improving locking and also facilitating manual unlocking between the female connector holder and a mating male tab holder of an electrical connector system compared with the systems known in the prior art. In particular, as shown in the examples illustrated by the accompanying figures, the invention allows a spring locking assurance device to be used in a similar way both for locking and for authorizing unlocking. While the device fulfils its function of automatic ejection of the male tab holder if the mating is not realised correctly, the same device, through a manual action on the part of the operator which is simplified compared with the known prior art, allows authorization of the disconnection of the male tab holder.

REFERENCE SIGNS

[0060]

100	locking assurance device
101	body
102	lance
103	lance
105	head
106	arm
107	arm
108	locking lug
109	locking lug
110	cavity
111	cavity
112	unlocking thrust surface
113	end surface
114	stop/thrust surface
115	unlocking element
116	unlocking surface
117	end surface
118	stop/thrust surface
119	lug

120	lug
200	female connector holder housing
201	body
202	upper part
5 203	lower part
204	accommodation portion
205	groove
206	groove
207	end wall
10 208	end wall
209	locking lance
210	unlocking surface
211	recess
300	female connector holder assembly
15 301	electrical contact housing
302	electrical contact terminal
303	electrical contact terminal
304	seal
400	male tab holder
20 401	body
402	locking lug
403	opening
404	edge
405	rib
25 406	locking surface
407	conductor passage
408	conductor passage
500	electrical connector system

30

Claims

1. Electrical connector system (500) comprising a locking assurance device (100) and a first connector housing (200) configured for being engageable with a second mating connector housing (400) that is capable of being locked therewith, wherein:

35

40

45

50

55

the locking assurance device (100) comprises at least one spring and is configured to be movably accommodated in the first housing (200) such that a displacement of the locking assurance device (100) in the first housing (200) from a delivery position causes a loading of the said at least one spring; and

the locking assurance device (100) is further configured such that, during an action of mating the second housing (400) into the first housing (200), the locking assurance device (100) is displaced from the delivery position by the second housing (400) such that the loading of the said at least one spring opposes the mating as long as the electrical connector system (500) is not in a locking state in which the second housing (400) is locked with the first housing (200), and the locking assurance device (100) is not returned to the delivery position; wherein the locking assurance device (100)

- comprises a body (101) configured for being movably accommodated, in particular in a sliding manner, in the first housing (200) in a mating direction of a second housing (400) into the first housing (200);
 and wherein the first housing (200) comprises a body (201) comprising an accommodation portion (204) which is a recess of geometry adapted to that of the locking assurance device (100);
characterised in that
 the locking assurance device (100) further comprises an unlocking thrust surface (112) configured such that, in the locking state, a displacement of the locking assurance device (100) from the delivery position by a thrust on the said unlocking thrust surface (112) causes a loading of the said at least one spring authorizing the unlocking of the first and second housings (200, 400).
2. Electrical connector system (500) according to claim 1, wherein the locking assurance device (100) is further configured such that the loading of the said at least one spring authorizing the transition to the locked state and/or unlocking from the locked state is a maximum relative loading of the said at least one spring.
 3. Electrical connector system (500) according to claims 1 or 2, wherein the locking assurance device (100) is further configured such that the loading of the said at least one spring authorizing the transition to the locked state is substantially the same as the loading authorizing the unlocking.
 4. Electrical connector system (500) according to any of the preceding claims, further comprising at least one thrust surface (114, 118), distinct from the said unlocking thrust surface (112), configured such that, during a mating action, a thrust exerted thereon, in particular by the second housing (400), causes the loading of the said at least one spring opposing the mating action.
 5. Electrical connector system (500) according to claim 4, further comprising at least one guide surface (116), wherein the locking assurance device (100) is further configured such that, during a displacement of the locking assurance device (100) from the delivery position, the said at least one guide surface (116) causes a displacement of a first locking element (209) of the first housing (200) authorizing the transition to the locking state and/or unlocking from the locking state.
 6. Electrical connector system (500) according to any of claims 1 to 5, wherein:

the first housing (200) comprises a first locking element (209) capable of being displaced, in particular resiliently, from a delivery position in which, in a locking state, the first locking element (209) is locked with a second locking element (402) of a second mating housing (400); and the electrical connector system (500) is further configured such that a loading of the said at least one spring causes a displacement of the first locking element (209) of the first housing (200) authorizing the transition to the locking state and/or unlocking from the locking state.

7. Electrical connector system (500) according to claim 6, in combination with a locking assurance device according to claim 5, wherein the electrical connector system (500) is further configured such that, in the locking state, the said at least one thrust surface (114, 118) is arranged relative to the second housing (400) such that a thrust exerted thereon is not permitted by the second housing (400).
8. Electrical connector system (500) according to claim 6 or 7, wherein the electrical connector system (500) is further configured such that, in the locking state, the unlocking thrust surface (112) is arranged out of reach of the second housing (400).

30 Patentansprüche

1. Elektrisches Verbinder-System (500), das eine Verriegelungs-Sicherungs­vorrichtung (100) und ein erstes Verbindergehäuse (200) umfasst, das so ausgeführt ist, dass es mit einem zweiten Gegen-Verbin­dergehäuse (400) in Eingriff gebracht werden kann, das damit verriegelt werden kann, wobei die Verriegelungs-Sicherungs­vorrichtung (100) wenigstens eine Feder umfasst und so ausgeführt ist, dass sie beweglich so in dem ersten Gehäuse (200) aufgenommen wird, dass eine Verschiebung der Verriegelungs-Sicherungs­vorrichtung (100) in dem ersten Gehäuse (200) aus einer Freigabeposition ein Spannen der wenigstens einen Feder bewirkt; und die Verriegelungs-Sicherungs­vorrichtung (100) des Weiteren so ausgeführt ist, dass während eines Vorgangs des Einpassens des zweiten Gehäuses (400) in das erste Gehäuse (200) die Verriegelungs-Sicherungs­vorrichtung (100) durch das zweite Gehäuse (400) aus der Freigabeposition verschoben wird, so dass das Spannen der wenigstens einen Feder dem Ineinanderverschieben entgegenwirkt, solange sich das elektrische Verbinder-System (500) nicht in einem Verriegelungszustand befindet, in dem das zweite Gehäuse (400) mit dem ersten Gehäuse (200) verriegelt ist, und die Verriegelungs-Sicherungs­vorrichtung (100) nicht in die Freigabeposition zurückge-

führt wird;

wobei die Verriegelungs-Sicherungs-
vorrichtung (100) einen Körper (101) umfasst, der so ausgeführt
ist, dass er in einer Richtung zum Einpassen eines
zweiten Gehäuses (400) in das erste Gehäuse (200)
beweglich, insbesondere gleitend, in dem ersten Ge-
häuse (200) aufgenommen wird;

und das erste Gehäuse (200) einen Körper (201)
umfasst, der einen Aufnahmeabschnitt (204) um-
fasst, der eine Aussparung mit einer Form ist, die an
die der Verriegelungs-Sicherungs-
vorrichtung (100) angepasst ist;

dadurch gekennzeichnet, dass

die Verriegelungs-Sicherungs-
vorrichtung (100) des Weiteren eine Entriegelungs-
Druckfläche (112) umfasst, die so ausgeführt ist, dass in dem Verriegelungs-
zustand eine Verschiebung der Verriegelungs-
Sicherungs-
vorrichtung (100) aus der Freigabe-
position durch einen Druck auf die Entriegelungs-
Druckfläche (112) ein Spannen der wenigstens einen Fe-
der bewirkt, die das Entriegeln des ersten und zwei-
ten Gehäuses (200, 400) zulässt.

2. Elektrisches Verbinder-System (500) nach An-
spruch 1, wobei die Verriegelungs-Sicherungs-
vorrichtung (100) des Weiteren so ausgeführt ist, dass
das Spannen der wenigstens einen Feder, das den
Übergang in den verriegelten Zustand und/oder En-
triegeln aus dem verriegelten Zustand zulässt, ein
maximales relatives Spannen der wenigstens einen
Feder ist.

3. Elektrisches Verbinder-System (500) nach An-
spruch 1 oder 2, wobei die Verriegelungs-Siche-
rungs-
vorrichtung (100) des Weiteren so ausgeführt
ist, dass das Spannen der wenigstens einen Feder,
das den Übergang in den verriegelten Zustand zu-
lässt, im Wesentlichen das gleiche ist wie das Span-
nen, das das Entriegeln zulässt.

4. Elektrisches Verbinder-System (500) nach einem
der vorangehenden Ansprüche, das des Weiteren
wenigstens eine Druckfläche (114, 118) umfasst, die
sich von der Entriegelungs-Druckfläche (112) un-
terscheidet und so ausgeführt ist, dass während eines
Einpassvorgangs ein, insbesondere durch das zwei-
te Gehäuse (400), darauf ausgeübter Druck das
Spannen der wenigstens einen Feder bewirkt, das
dem Einpassvorgang entgegenwirkt.

5. Elektrisches Verbinder-System (500) nach An-
spruch 4, das des Weiteren wenigstens eine Füh-
rungsfläche (116) umfasst, wobei die Verriegelungs-
Sicherungs-
vorrichtung (100) des Weiteren so aus-
geführt ist, dass bei einer Verschiebung der Verrie-
gelungs-Sicherungs-
vorrichtung (100) aus der Frei-
gabeposition die wenigstens eine Führungsfläche
(116) eine Verschiebung eines ersten Verriege-

lungselementes (209) des ersten Gehäuses (200)
bewirkt, die den Übergang in den Verriegelungs-
zustand und/oder Entriegeln aus dem Verriegelungs-
zustand zulässt.

6. Elektrisches Verbinder-System (500) nach einem
der Ansprüche 1 bis 5, wobei
das erste Gehäuse (200) ein erstes Verriegelungs-
element (209) umfasst, das, insbesondere elastisch,
aus einer Freigabeposition verschoben werden
kann, in der in einem Verriegelungszustand das erste
Verriegelungselement (209) mit einem zweiten
Verriegelungselement (402) eines zweiten Gegen-
Gehäuses (400) verriegelt ist; und
das elektrische Verbinder-System (500) des Weiteren
so ausgeführt ist, dass ein Spannen der wenig-
stens einen Feder eine Verschiebung des ersten Ver-
riegelungselementes (209) des ersten Gehäuses
(200) bewirkt, die den Übergang in den Verriege-
lungszustand und/oder Entriegeln aus dem Verrie-
gelungszustand zulässt.

7. Elektrisches Verbinder-System (500) nach An-
spruch 6, in Kombination mit einer Verriegelungs-
Sicherungs-
vorrichtung nach Anspruch 5, wobei das
elektrische Verbinder-System (500) des Weiteren so
ausgeführt ist, dass in dem Verriegelungszustand
die wenigstens eine Druckfläche (114, 118) relativ
zu dem zweiten Gehäuse (400) so angeordnet ist,
dass ein darauf ausgeübter Druck durch das zweite
Gehäuse (400) nicht zugelassen wird.

8. Elektrisches Verbinder-System (500) nach An-
spruch 6 oder 7, wobei das elektrische Verbinder-
System (500) des Weiteren so ausgeführt ist, dass
in dem Verriegelungszustand die Entriegelungs-
Druckfläche (112) außerhalb der Reichweite des
zweiten Gehäuses (400) angeordnet ist.

40

Revendications

1. Système connecteur électrique (500) comprenant
un dispositif de sécurisation de verrouillage (100) et
un premier boîtier de connecteur (200) configuré
pour pouvoir mettre mis en prise avec un second
boîtier de connecteur d'accouplement (400) qui peut
être verrouillé avec lui, dans lequel :

50

le dispositif de sécurisation de verrouillage (100)
comprend au moins un ressort et est configuré
pour être reçu de manière mobile dans le pre-
mier boîtier (200) de façon qu'un déplacement
du dispositif de sécurisation de verrouillage
(100) dans le premier boîtier (200) lui faisant
quitter une position de livraison provoque un
chargement dudit au moins un ressort ; et
le dispositif de sécurisation de verrouillage (100)

55

est en outre configuré de façon que, durant une action d'accouplement du second boîtier (400) dans le premier boîtier (200), le dispositif de sécurisation de verrouillage (100) est déplacé de la position de livraison par le second boîtier (400) de sorte que le chargement dudit au moins un ressort s'oppose à l'accouplement tant que le système connecteur électrique (500) n'est pas dans un état de verrouillage dans lequel le second boîtier (400) est verrouillé avec le premier boîtier (200), et que le dispositif de sécurisation de verrouillage (100) n'est pas revenu à la position de livraison ;

dans lequel le dispositif de sécurisation de verrouillage (100) comprend un corps (101) configuré pour être reçu de manière mobile, notamment de manière coulissante, dans le premier boîtier (200) dans une direction d'accouplement d'un second boîtier (400) dans le premier boîtier (200) ;

et dans lequel le premier boîtier (200) comprend un corps (201) comprenant une partie de réception (204) qui est une cavité de géométrie adaptée à celle du dispositif de sécurisation de verrouillage (100) ;

caractérisé en ce que

le dispositif de sécurisation de verrouillage (100) comprend en outre une surface de poussée de déverrouillage (112) configurée de façon que, dans l'état de verrouillage, un déplacement du dispositif de sécurisation de verrouillage (100), lui faisant quitter la position de livraison, par une poussée sur ladite surface de poussée de déverrouillage (112) provoque un chargement dudit au moins un ressort autorisant le déverrouillage des premier et second boîtiers (200, 400).

2. Système connecteur électrique (500) selon la revendication 1, dans lequel le dispositif de sécurisation de verrouillage (100) est en outre configuré de façon que le chargement dudit au moins un ressort autorisant la transition vers l'état verrouillé et/ou un déverrouillage depuis l'état verrouillé est un chargement relatif maximum dudit au moins un ressort.
3. Système connecteur électrique (500) selon la revendication 1 ou 2, dans lequel le dispositif de sécurisation de verrouillage (100) est en outre configuré de façon que le chargement dudit au moins un ressort autorisant la transition vers l'état verrouillé est sensiblement le même que le chargement autorisant le déverrouillage.
4. Système connecteur électrique (500) selon l'une quelconque des revendications précédentes, comprenant en outre au moins une surface de poussée (114, 118), distincte de ladite surface de poussée de déverrouillage (112), configurée de façon que, du-

rant une action d'accouplement, une poussée exercée sur elle, notamment par le second boîtier (400), provoque le chargement dudit au moins un ressort s'opposant à l'action d'accouplement.

5. Système connecteur électrique (500) selon la revendication 4, comprenant en outre au moins une surface guide (116), dans lequel le dispositif de sécurisation de verrouillage (100) est en outre configuré de façon que, durant un déplacement du dispositif de sécurisation de verrouillage (100) lui faisant quitter la position de livraison, ladite au moins une surface guide (116) provoque un déplacement d'un premier élément de verrouillage (209) du premier boîtier (200) autorisant la transition vers l'état de verrouillage et/ou un déverrouillage depuis l'état de verrouillage.
6. Système connecteur électrique (500) selon l'une quelconque des revendications 1 à 5, dans lequel :

le premier boîtier (200) comprend un premier élément de verrouillage (209) pouvant être déplacé, en particulier de manière élastique, depuis une position de livraison dans laquelle, dans un état de verrouillage, le premier élément de verrouillage (209) est verrouillé avec un second élément de verrouillage (402) d'un second boîtier d'accouplement (400) ; et

le système connecteur électrique (500) est en outre configuré de façon qu'un chargement dudit au moins un ressort provoque un déplacement du premier élément de verrouillage (209) du premier boîtier (200) autorisant la transition vers l'état de verrouillage et/ou un déverrouillage depuis l'état de verrouillage.

7. Système connecteur électrique (500) selon la revendication 6, en combinaison avec un dispositif de sécurisation de verrouillage selon la revendication 5, dans lequel le système connecteur électrique (500) est en outre configuré de façon que, dans l'état de verrouillage, ladite au moins une surface de poussée (114, 118) est agencée par rapport au second boîtier (400) de façon que le second boîtier (400) ne puisse pas exercer une poussée sur elle.
8. Système connecteur électrique (500) selon la revendication 6 ou 7, dans lequel le système connecteur électrique (500) est en outre configuré de façon que, dans l'état de verrouillage, la surface de poussée de déverrouillage (112) soit agencée de manière à être hors de portée du second boîtier (400).

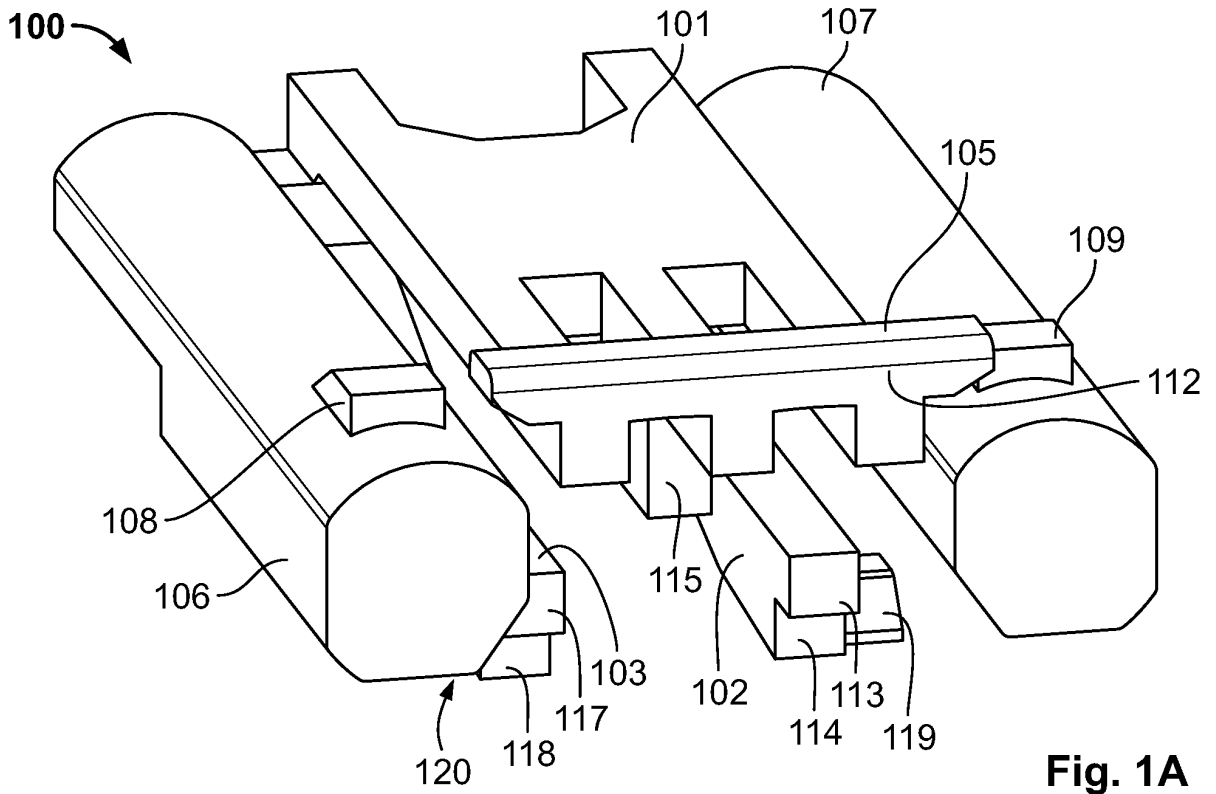

Fig. 1A

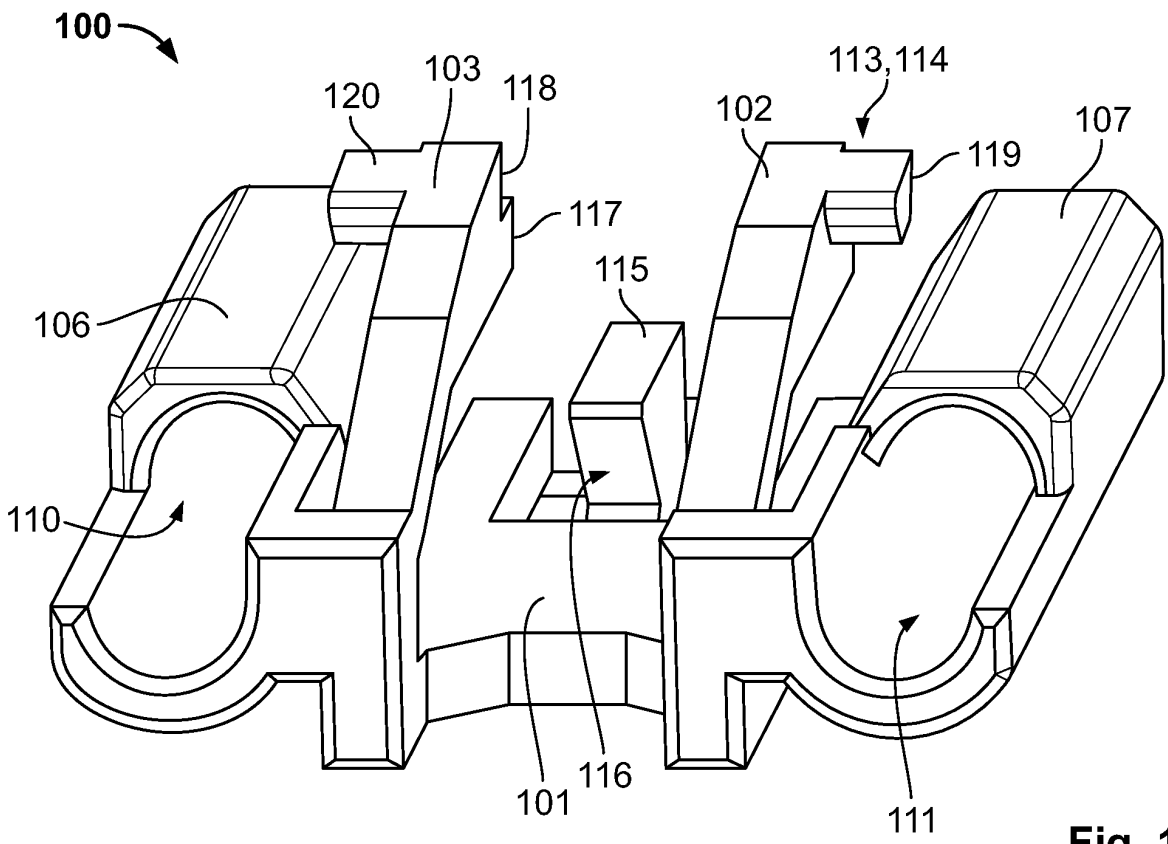

Fig. 1B

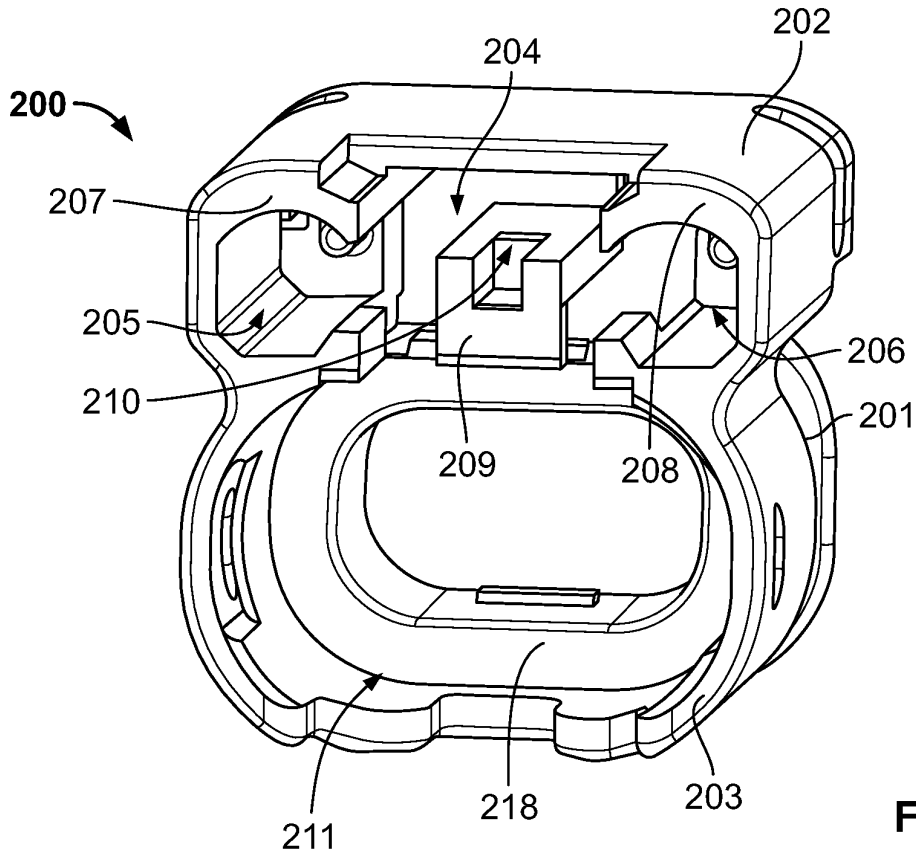

Fig. 2

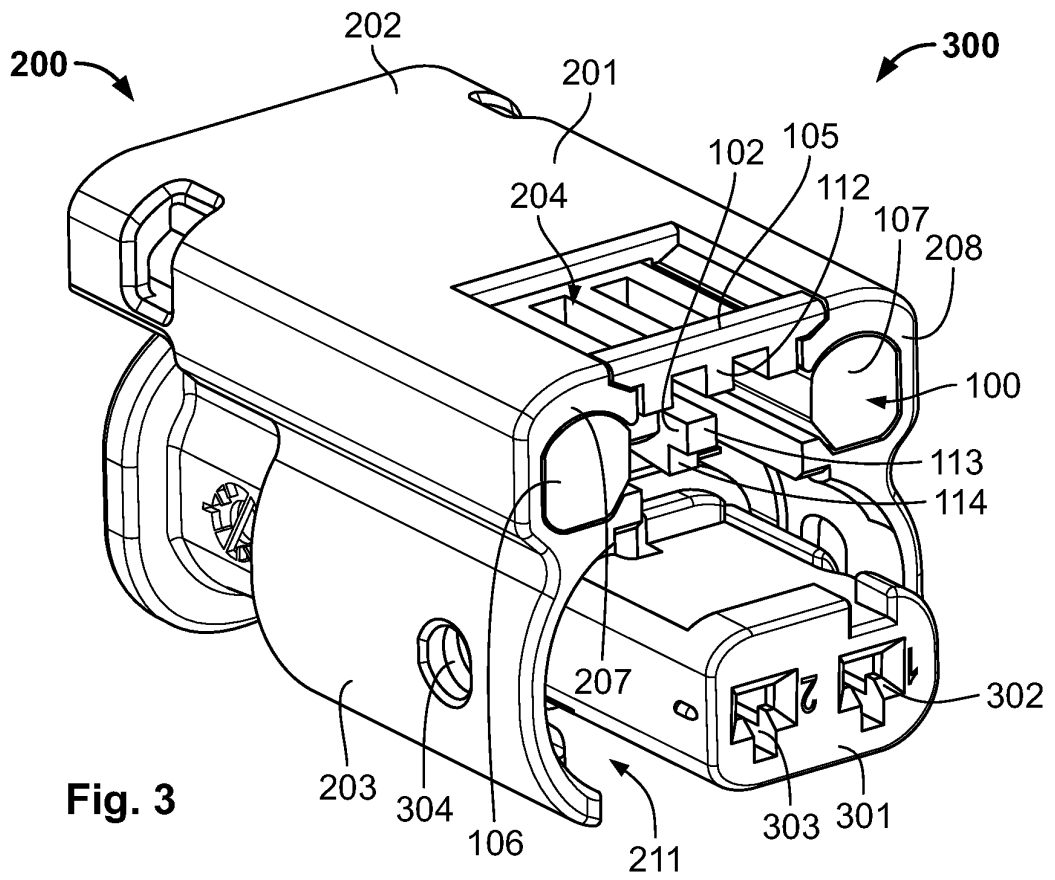

Fig. 3

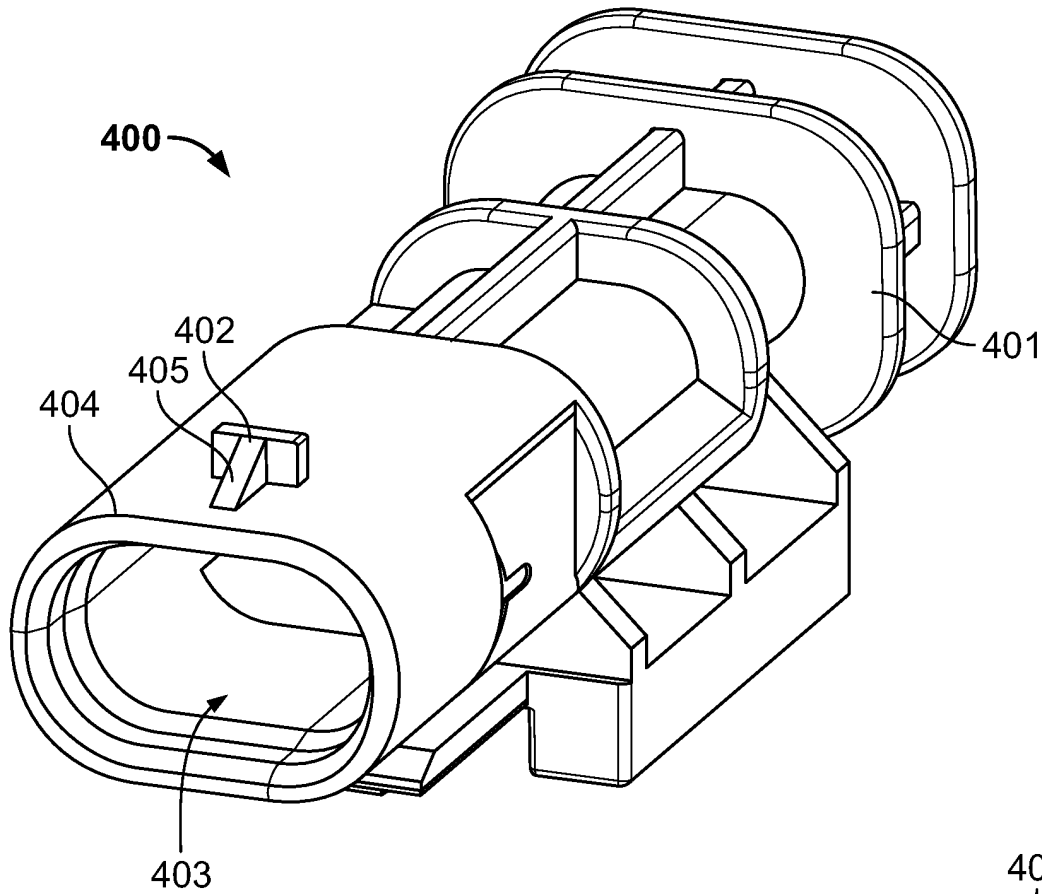

Fig. 4A

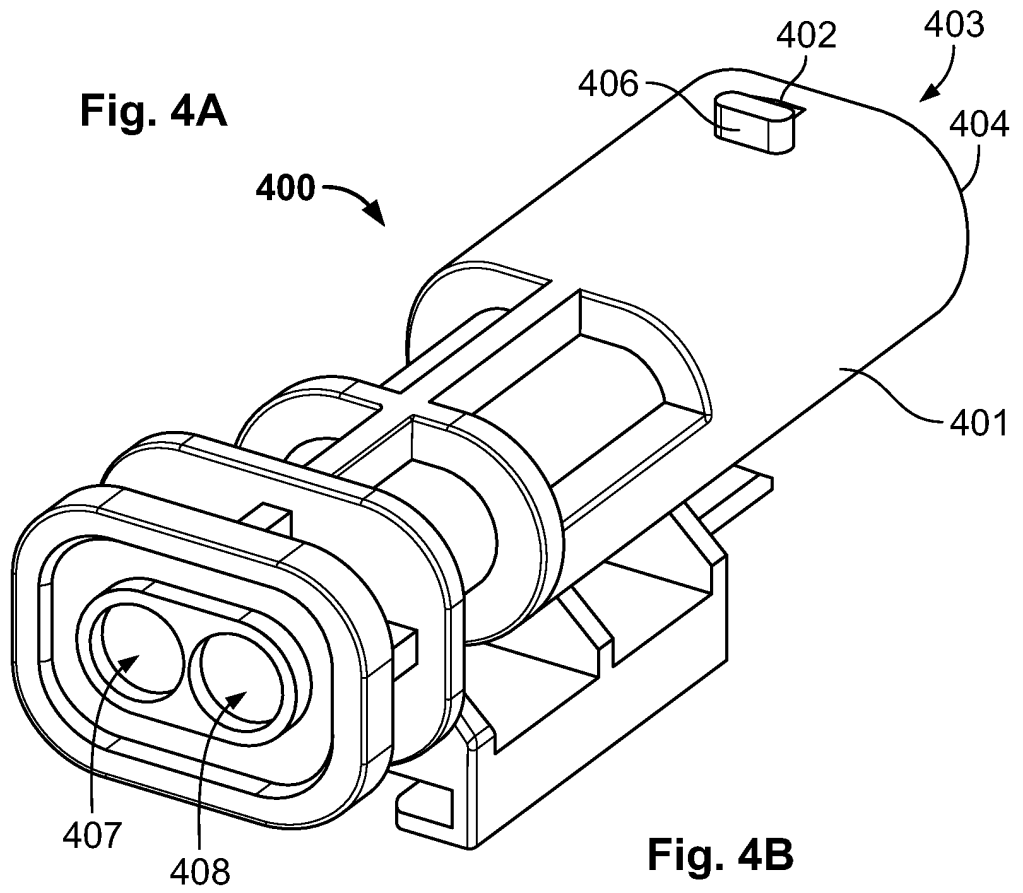

Fig. 4B

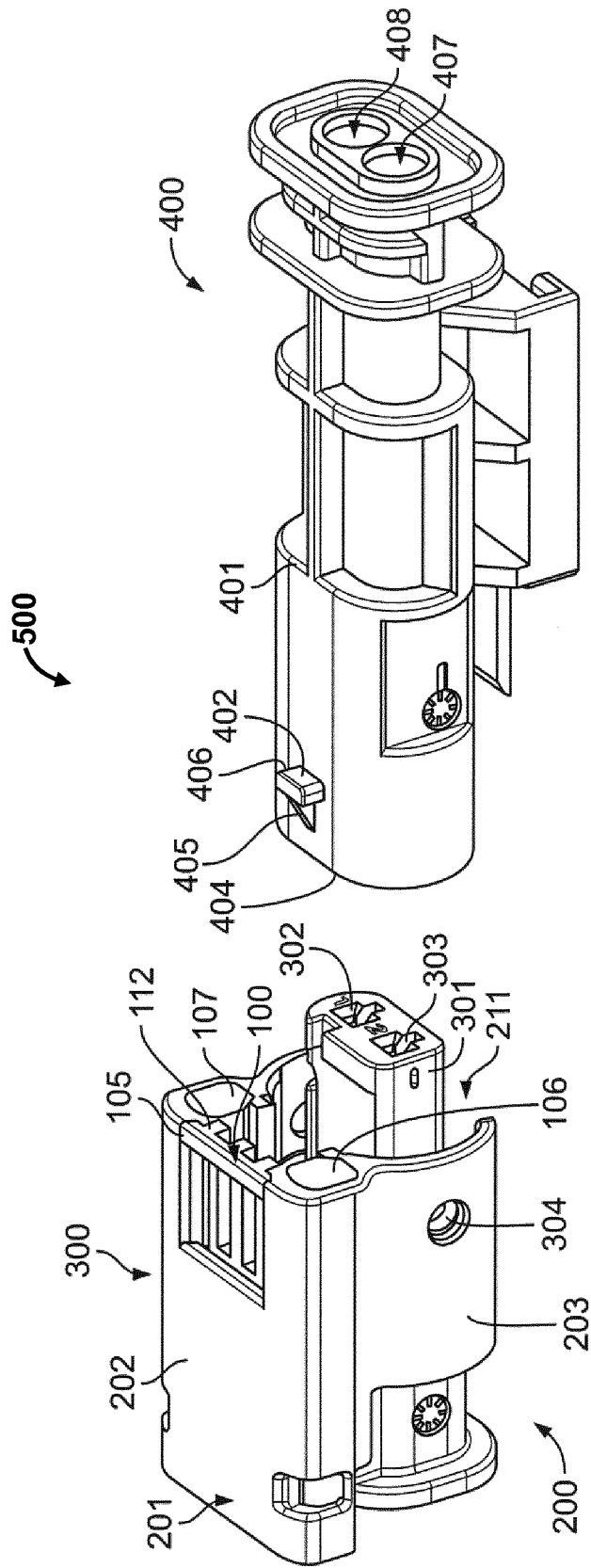

Fig. 5A

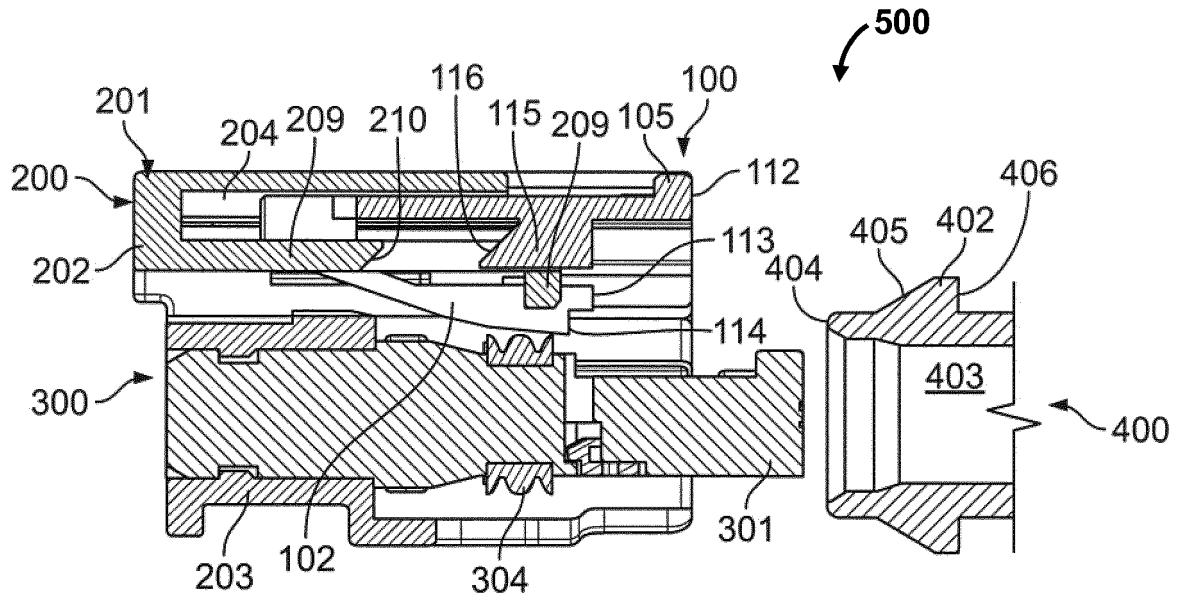

Fig. 5B

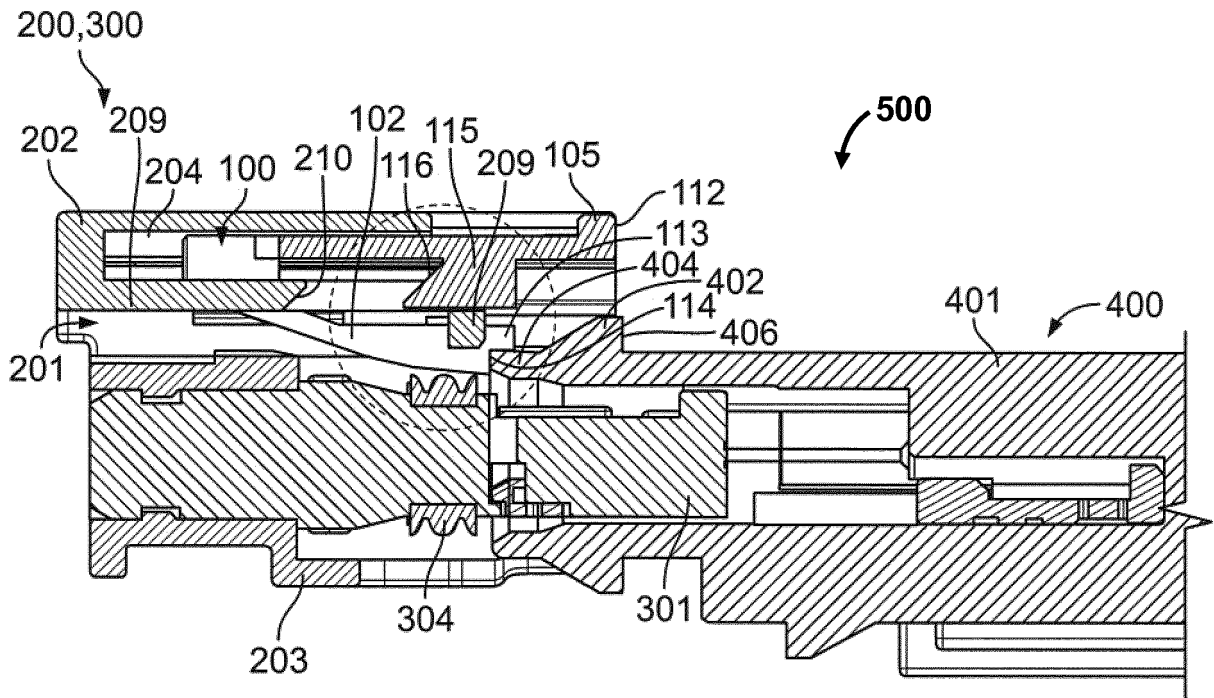

Fig. 6A

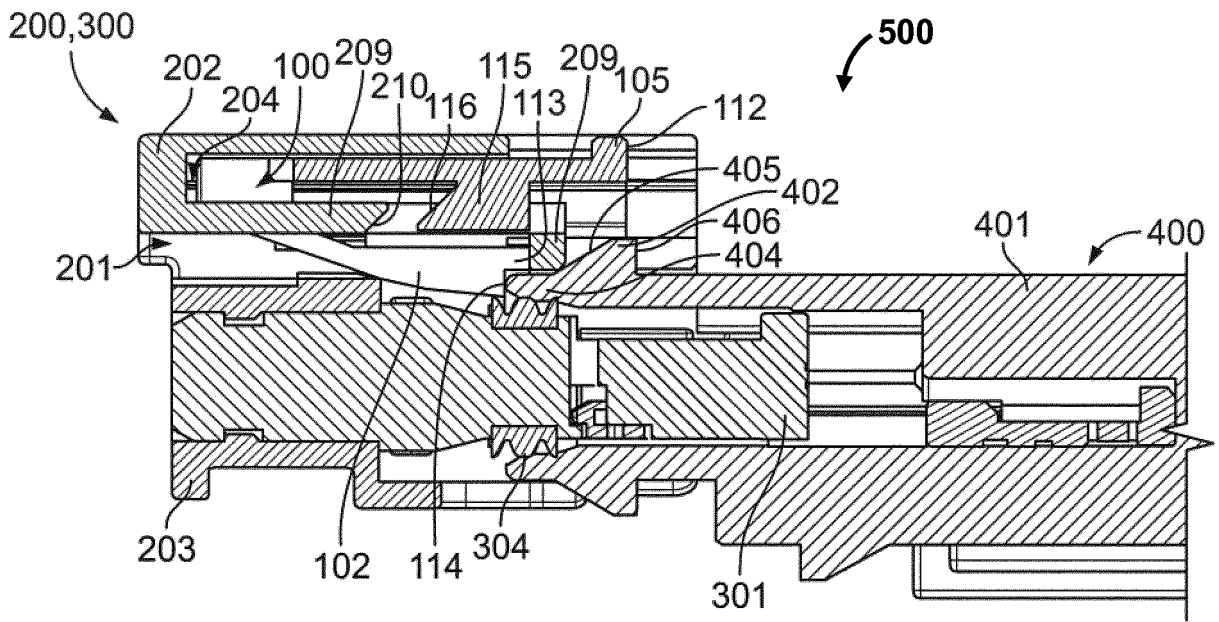

Fig. 6B

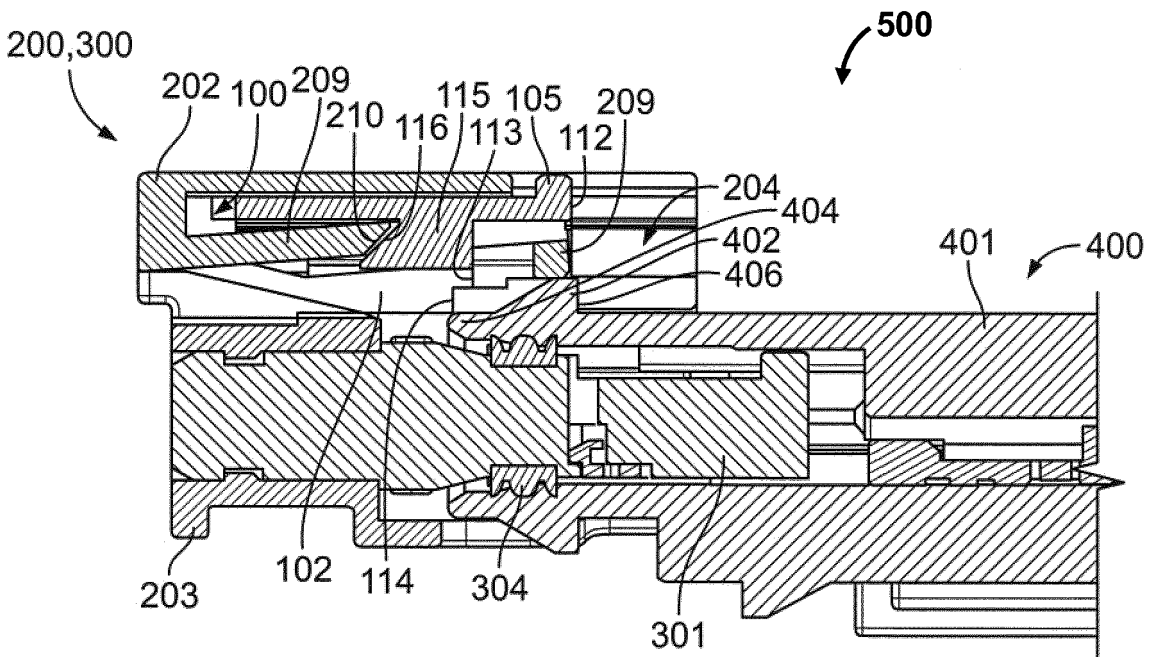

Fig. 6C

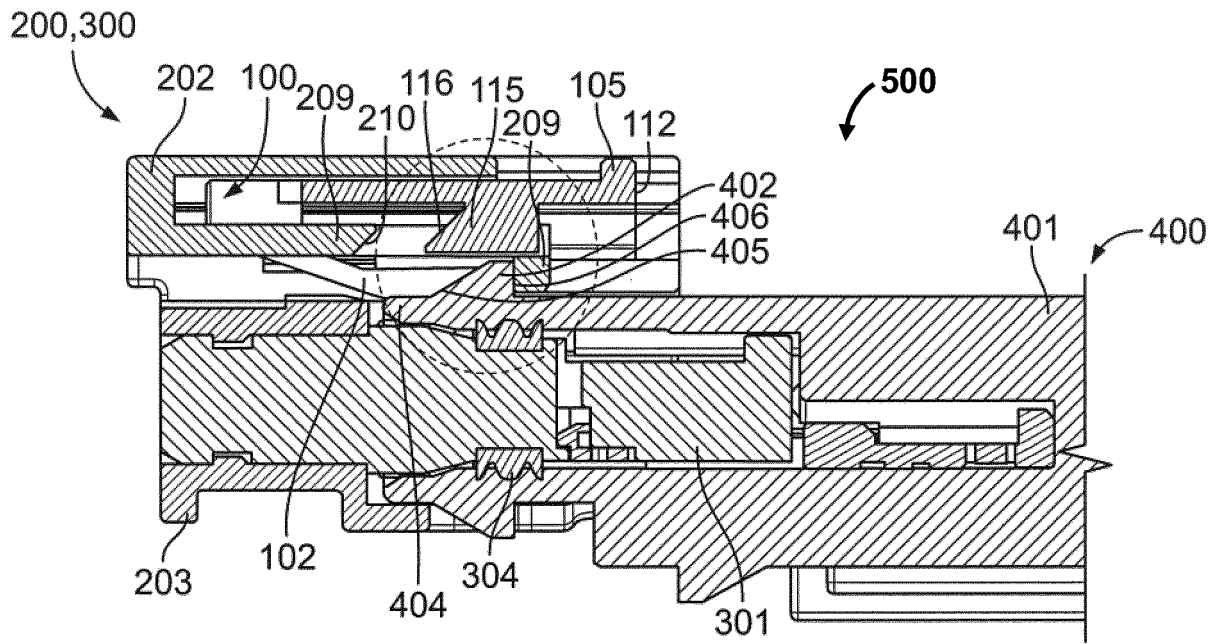

Fig. 6D

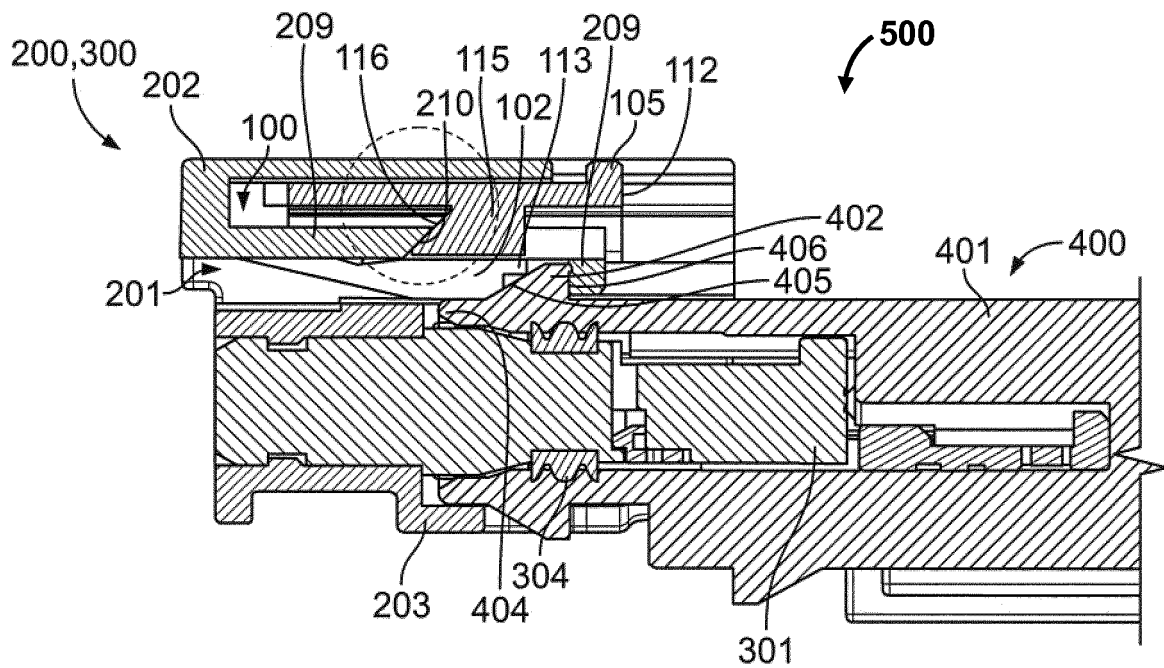

Fig. 7A

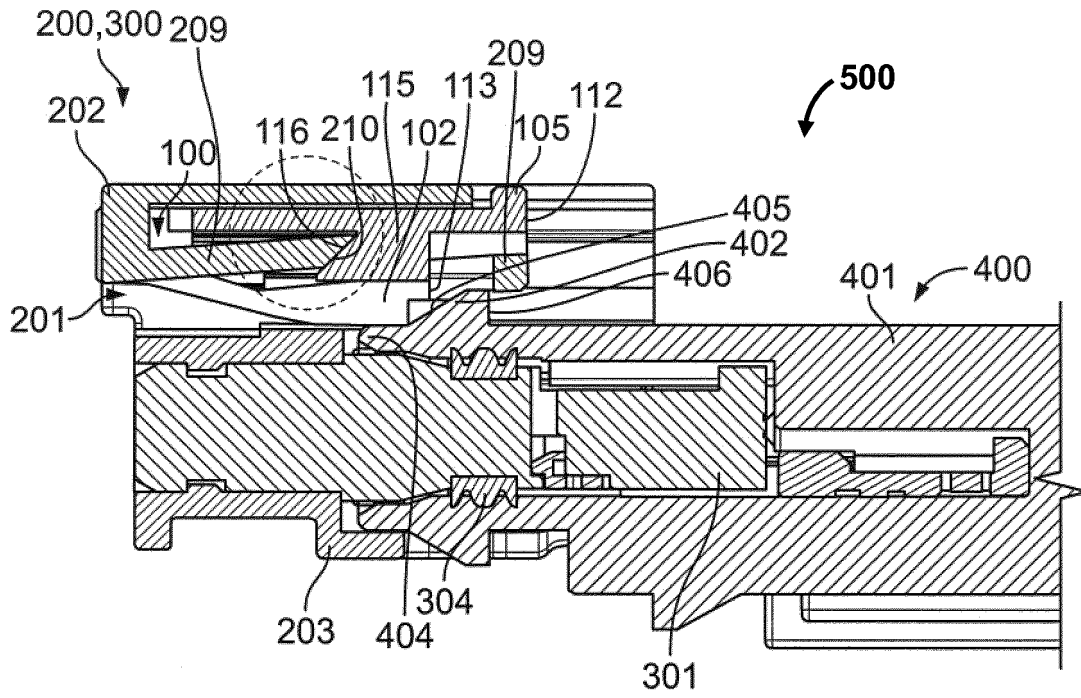

Fig. 7B

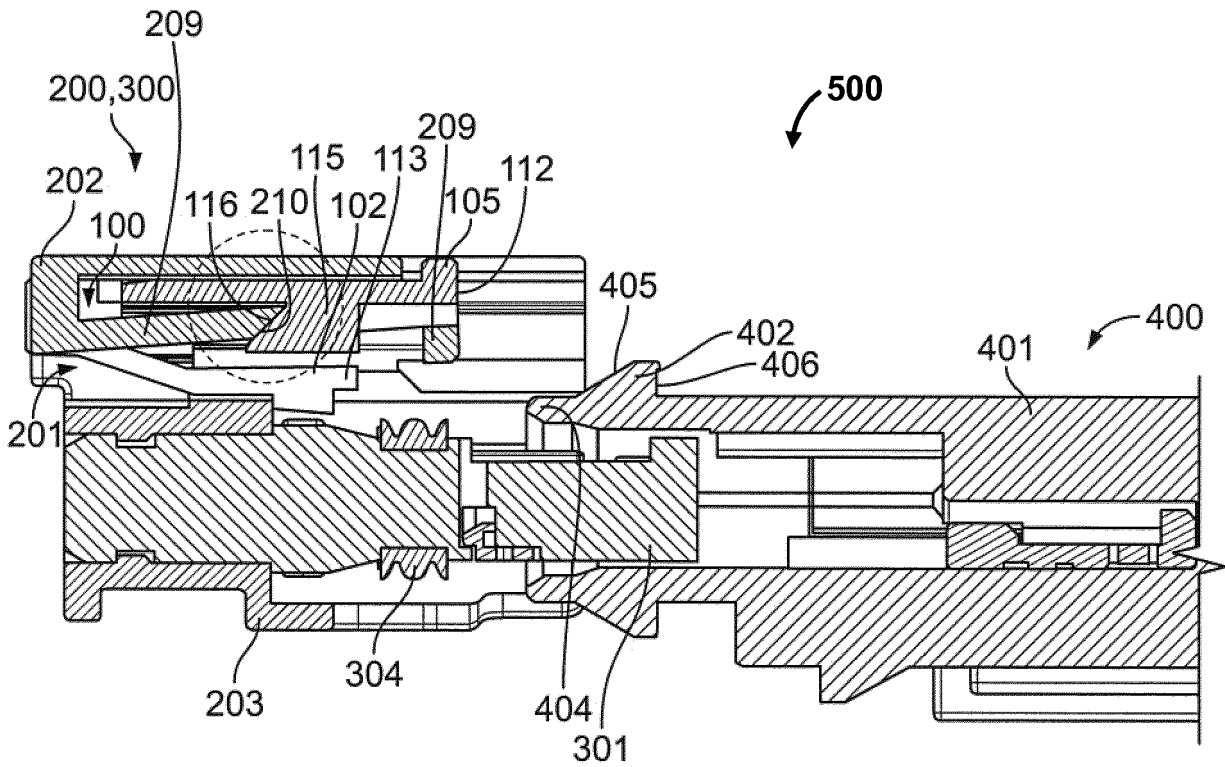

Fig. 7C

REFERENCES CITED IN THE DESCRIPTION

This list of references cited by the applicant is for the reader's convenience only. It does not form part of the European patent document. Even though great care has been taken in compiling the references, errors or omissions cannot be excluded and the EPO disclaims all liability in this regard.

Patent documents cited in the description

- US 2004102075 A1 [0008]
- FR 3008833 A1 [0009]