

(19)



(11)

EP 3 249 672 B1

(12)

EUROPEAN PATENT SPECIFICATION

(45) Date of publication and mention of the grant of the patent:
27.03.2019 Bulletin 2019/13

(51) Int Cl.:
H01H 9/04 (2006.01) H01H 13/86 (2006.01)

(21) Application number: **17172877.7**

(22) Date of filing: **24.05.2017**

(54) **EXPLOSION-PROOF PUSH-BUTTON PANEL FOR REMOTE ELECTRIC CONTROL VIA CABLE**
EXPLOSIONSGESCHÜTZTE DRUCKKNOPFTAFEL FÜR FERNBEDIENUNG ÜBER KABEL
PANNEAU BOUTON-POUSSOIR ANTIDÉFLAGRANT À DISTANCE PAR LE INTERMÉDIAIRE D'UN CÂBLE DE COMMANDE ÉLECTRIQUE

(84) Designated Contracting States:
AL AT BE BG CH CY CZ DE DK EE ES FI FR GB GR HR HU IE IS IT LI LT LU LV MC MK MT NL NO PL PT RO RS SE SI SK SM TR

(30) Priority: **27.05.2016 IT UA20163879**

(43) Date of publication of application:
29.11.2017 Bulletin 2017/48

(73) Proprietors:
• **Paone, Andrea**
27010 Siziano (PV) (IT)
• **Paone, Guido**
27010 Siziano (PV) (IT)

(72) Inventors:
• **Paone, Andrea**
27010 Siziano (PV) (IT)
• **Paone, Guido**
27010 Siziano (PV) (IT)

(74) Representative: **Borsano, Corrado et al**
Metroconsult S.r.l.
Foro Buonaparte, 51
20121 Milano (IT)

(56) References cited:
EP-A1- 3 065 155 WO-A1-2016/077660
US-A- 3 236 989 US-A1- 2011 214 976

EP 3 249 672 B1

Note: Within nine months of the publication of the mention of the grant of the European patent in the European Patent Bulletin, any person may give notice to the European Patent Office of opposition to that patent, in accordance with the Implementing Regulations. Notice of opposition shall not be deemed to have been filed until the opposition fee has been paid. (Art. 99(1) European Patent Convention).

Description

Field of the invention

[0001] The present invention relates to an explosion-proof push-button panel for remote electric control via cable.

Background art

[0002] Electric apparatuses are commonly used in potentially explosive environments. An explosion may occur in the presence of potentially explosive atmosphere conditions.

[0003] A potentially explosive atmosphere may be composed of a mixture of air and inflammable substances in the form of gas, vapour, mist or dust, in which, after ignition, combustion propagates rapidly (by explosion) at atmospheric pressure.

[0004] Electric apparatuses must therefore be so designed as to avoid the risk of an explosion that might be generated by sparks or electric discharges caused, for example, by the switching of electric switches; therefore, they must have explosion-proof characteristics.

[0005] The push-button panels known in the art for remote electric control via cable, for use in a potentially explosive environment, comprise a number of electric switches, each one having explosion-proof characteristics and controllable from the outside, enclosed in an enclosure having non-explosion-proof characteristics.

[0006] US3236989-A describes an explosion-proof electrical control device which includes electrical switches whose movement is controlled by springs.

[0007] However, such configurations are not optimal to ensure an adequate level of explosion-proof protection.

[0008] Furthermore, particular characteristics in terms of ergonomics, lightness, strength, compactness, ease of use, manoeuvrability, service life, ease of assembly and disassembly are also required.

Summary of the invention

[0009] It is therefore one object of the present invention to provide an explosion-proof push-button panel for remote electric control via cable, which can solve the above-mentioned problems.

[0010] The present invention relates to an explosion-proof push-button panel for remote electric control via cable, characterized in that it comprises:

- a hollow base and a cover;
- a board, internal to said hollow base;
- one or more electric switches having non-explosion-proof characteristics, secured to said board inside said hollow base;
- one or more movable cylinders, for each one of said electric switches, inside said hollow base, said mov-

able cylinders being adapted to control the opening and closing of corresponding switches to which they are secured;

- one or more pistons capable of sliding through corresponding holes in said cover, said pistons being adapted to engage against corresponding cylinders and to be actuated from the outside of the push-button panel for causing said cylinders to move;
- one or more elastic silicone bands secured to the inner surface of the cover, in correspondence with said holes, so as to elastically adhere to the base of the piston and ensure that the latter will elastically return into the idle position following actuation, one elastic silicone band being present for each piston;
- said hollow base and said cover being adapted to form an operationally closed metal enclosure having explosion-proof characteristics.

[0011] It is a particular object of the present invention to provide a push-button panel for remote electric control via cable in an explosion-proof environment as set out in detail in the claims, which are an integral part of the present description.

Brief description of the drawings

[0012] Further objects and advantages of the present invention will become apparent from the following detailed description of an example of embodiment thereof and from the annexed drawings, which are only supplied by way of non-limiting example, wherein:

Figure 1 shows a sectional side view of the push-button panel of the invention;

Figure 2 shows a sectional side view of the hollow base of the push-button panel;

Figure 3 is a sectional side view of the push-button panel with a part thereof magnified, showing some details of the switches;

Figure 4 is a top view of the two parts that make up the push-button panel, i.e. the hollow base and the cover;

Figure 5 shows a variant of the cover and board of the push-button panel, which includes two sets of electric switches;

Figure 6 shows one example of embodiment of the band;

Figure 7 shows one example of embodiment of a push-button covering ring;

Figure 8 shows three views of the cover, to which the bands can be applied;

Figure 9 shows some views of one variant of the hollow base and of the cover of the push-button panel.

[0013] In the drawings, the same reference numerals and letters identify the same items or components.

Detailed description

[0014] With reference to the drawings, the push-button panel comprises a hollow base 1 and a cover 2. In operation, the cover is closed directly onto the base by means of screws 15. It is not necessary to put any gaskets on the sealing edge; one may possibly apply some grease to effect a water-resistant closure in compliance with the IP66 standard.

[0015] The push-button panel comprises a number of electric switches 3, each one comprising a movable cylinder 4 adapted to control the opening and closing of the electric switch through a reciprocating vertical motion within the switch 3. The switches are advantageously of the non-explosion-proof type. The head of the cylinder 4 has a cavity 4'. The switches and the corresponding cylinders are internal to the hollow body, and hence internal to the push-button panel, when the latter is closed.

[0016] The cover 2 has a number of holes 7, through each one of which a piston 5 can slide, the head 5' of which protrudes past the outer edge of the cover and can thus be actuated from the outside. Conversely, the terminal part of the piston, which is inside the hollow body and hence inside the push-button panel when the latter is closed, has a protrusion 5" adapted to engage into the cavity 4' of a corresponding cylinder 4, so as to either stop or allow the flow of current towards the switch. Therefore, the cylinders and the pistons are in corresponding positions in the push-button panel, when the latter is closed.

[0017] In the holes 7, through which the pistons 5 can slide, bushings 13 are provided for supporting the pistons. The bushings have a hollow T-shape. In the cavity, the corresponding piston can slide. The size of the cavity is such as to minimize the width difference with respect to the piston, with controlled tolerance. The bushings are preferably screwed into the corresponding holes of the cover, so that the wider upper portion of the bushing will adhere to the outer part of the cover.

[0018] The switches 3 are secured onto a board 6, to which the electric wires connected to the switch are connected to ensure the flow of current.

[0019] The piston 5 must be able to elastically engage, in a retractable manner, from a non-actuation position, e.g. the retracted position, proximal to the outside of the push-button panel, to an actuation position, e.g. a position in which it protrudes more into the push-button panel. In order to ensure the elastic movement of the cylinder, an elastic silicone band 9 is secured to the inner surface of the cover in correspondence with the hole through which the piston can slide (one band per piston), so as to elastically adhere to the piston base 5". The pressure exerted by the piston from the outside causes the band to elastically extend, and when the piston is released the band will return into the idle position, resulting in the piston also returning into the idle position. Advantageously, each piston is fitted with a corresponding band.

[0020] Silicone is a high-performance, long-lasting

elastic material which is not subject to modification of its elastic properties or to deformation, and which can resist to a wide range of temperatures, from - 60° to + 180°, thus being able to ensure an operating temperature range of the push-button panel from - 40° to + 60°. Its characteristics, therefore, provide an improvement over the known use of a spring between the piston and the cylinder. In fact, the spring might come out of position or be lost while opening or closing the cover during assembly or repair work, because it lies unconstrained in a recess of the cylinder. Moreover, the duration and elasticity characteristics of the spring can easily deteriorate over time. The silicone band can be obtained from a silicone sheet having a thickness of, for example, 1 mm.

[0021] The base has a lateral hole 10 that houses a sealing ring (not shown in the drawings) of an electric wire bundle (not shown in the drawings) forming an appropriately insulated electric cable penetrating into the base, so that the various electric wires, also appropriately insulated, can be connected to the respective switches. The opposite end of the electric cable, which has a suitable length, is connected to the apparatus to be controlled.

[0022] The board 6 is fastened to the bottom of the base 1 by means of long screws 16, so that it can be easily inserted, lifted or removed. The length of said screws is such that they protrude past the top edge of the switches.

[0023] The base 1 has a cavity 11 under the board 6, so that it can house an anti-condensate resistor (also known as heater), i.e. a heating resistor (not shown in the drawings) to which power is supplied by electric wires of the bundle in order to keep the entire push-button panel at a controlled temperature, e.g. for better operator comfort in a cold outside environment. It is also useful to prevent freezing or condensate formation inside the push-button panel, which might even become filled with water, e.g. due to a wide temperature range (day/night).

[0024] The hollow base and the cover are advantageously made from die-cast aluminium, whereas the piston is made of 316 stainless steel (marine-grade steel), and the cylinder and the bushing are made of brass. Any other rigid metallic material can nevertheless be used. Advantageously, the hollow base has a rounded outline 12 for better and more comfortable handling and gripping.

[0025] External coverings 14 for the switches are also provided, e.g. made of plastic material, which are applied, e.g. by means of screws, onto the outer surface of the cover.

[0026] The length of the cover, of the base and of the board may be such as to allow accommodating one or two sets of electric switches.

[0027] The above-described non-limiting example of embodiment may be subject to variations without departing from the protection scope of the present invention, including all equivalent designs known to a man skilled in the art.

[0028] For example, one variant (Figure 9) includes a

so-called lamination joint 20, i.e. a perpendicular extension on the perimetric inner edge of the cover 2 that fits into a corresponding recess 21 on the perimetric inner edge of the hollow base 1, for the purpose of preventing flames from coming out in the event of an explosion, thus improving the explosion-proof characteristics of the push-button panel.

[0029] The elements and features shown in the various preferred embodiments may be combined together without however departing from the protection scope of the present invention. The advantages deriving from the application of the present invention are apparent. Common switches can be used, since they are completely protected by the explosion-proof enclosure.

[0030] Conversely, prior-art push-button panels make use of non-explosion-proof enclosures and explosion-proof switches.

[0031] This provides a higher level of protection, thus covering protection classes so far left uncovered, in compliance with current regulations for potentially explosive areas such as the ATEX, IECEx and UL standards. In particular, for the ATEX standard: Ex II 2G Ex d IIC T6 Gb; Ex II 2D Ex tb IIIC T85°C Db IP6X; Tamb: -20°C;+60°C. For the IECEx standard: Ex d IIC T6 Gb; Ex tb IIIC T90°C Db IP6X; Tamb: -20°C;+60°C. For the ULus standard: Class I Division 1 Group A, B, C&D T6; Tamb: - 25°C;+60°C. For the cUL standard: Class I Division 1 Group A, B, C&D T6; Tamb: - 25°C;+60°C.

[0032] The explosion-proof characteristic is thus transferred from the switch to the enclosure.

[0033] From the above description, those skilled in the art will be able to produce the object of the invention without introducing any further construction details.

Claims

1. Explosion-proof push-button panel for remote electric control via cable, comprising:

- a hollow base (1) and a cover (2);
- a board (6), internal to said hollow base (1);
- one or more electric switches having non-explosion-proof characteristics (3), secured to said board inside said hollow base (1);
- one or more movable cylinders (4), for each one of said electric switches (3), inside said hollow base (1), said movable cylinders (4) being adapted to control the opening and closing of corresponding switches to which they are secured;
- one or more pistons (5) capable of sliding through corresponding holes (7) in said cover (2), said pistons being adapted to engage against corresponding cylinders (4) and to be actuated from the outside of the push-button panel, when the latter is closed, for causing said cylinders to move:

- said hollow base (1) and said cover (2) being adapted to form an operationally closed metal enclosure having explosion-proof characteristics;

characterized in that, the explosion-proof push-button panel further comprises:

- one or more elastic silicone bands (9) secured to the inner surface of the cover, in correspondence with said holes (7), so as to elastically adhere to the base of said one or more pistons (5) and ensure that the latter will elastically return into the idle position following actuation, one elastic silicone band being present for each piston.

2. Explosion-proof push-button panel for remote electric control via cable according to claim 1, comprising one or more bushings (13), one for each of said holes (7), acting as supports for said pistons, said bushings having a hollow T-shape, within which a corresponding piston can slide.

3. Explosion-proof push-button panel for remote electric control via cable according to claim 1, wherein said base (1) has a cavity (11) under said board (6) for housing at least one anti-condensate resistor.

4. Explosion-proof push-button panel for remote electric control via cable according to claim 1, wherein said board (6) is fastened by means of long screws (16) to the bottom of the base (1), so that it can be easily inserted, lifted or removed, the length of said screws being such that they protrude past the top edge of the switches.

5. Explosion-proof push-button panel for remote electric control via cable according to claim 1, wherein the base (1) comprises a lateral hole (10) that houses a sealing ring of an electric cable penetrating into the base, so that the electric wires of the cable can be connected to the respective electric switches.

6. Explosion-proof push-button panel for remote electric control via cable according to claim 1, comprising external coverings (14) for said one or more switches (7), applied to the outer surface of said cover (2).

7. Explosion-proof push-button panel for remote electric control via cable according to claim 1, wherein said base (1) has a rounded outline (12).

8. Explosion-proof push-button panel for remote electric control via cable according to claim 2, wherein the hollow base, the cover, the pistons, the bushings are made of metallic material.

9. Explosion-proof push-button panel for remote electric control via cable according to claim 1, wherein said cover comprises, on its perimetric inner edge, a lamination joint (20) adapted to fit into a corresponding recess (21) on the perimetric inner edge of said hollow base (1).

Patentansprüche

1. Explosionsgeschützte Druckknopftafel für elektrische Fernbedienung über Kabel, umfassend:

- eine hohle Basis (1) und einen Deckel (2);
- eine Platte (6), intern zu der hohlen Basis (1);
- einen oder mehrere nicht-explosionsgeschützte Eigenschaften (3) aufweisende elektrische Schalter, die an der Platte innerhalb der hohlen Basis (1) gesichert sind;
- einen oder mehrere bewegliche Zylinder (4) für jeden der elektrischen Schalter (3), innerhalb der hohlen Basis (1), wobei die beweglichen Zylinder (4) angepasst sind, um das Öffnen und Schließen von entsprechenden Schaltern, an denen sie gesichert sind, zu steuern;
- einen oder mehrere Kolben (5), die imstande sind, durch entsprechende Löcher (7) in dem Deckel (2) zu gleiten, wobei die Kolben angepasst sind, um gegen entsprechende Zylinder (4) einzugreifen und um von der Außenseite der Druckknopftafel betätigt zu werden, wenn letztere geschlossen ist, um die Zylinder dazu zu bringen, sich zu bewegen;
- wobei die hohle Basis (1) und der Deckel (2) angepasst sind, um eine betrieblich geschlossene Metalleinhausung zu bilden, die explosionsgeschützte Eigenschaften aufweist;

dadurch gekennzeichnet, dass die explosionsgeschützte Druckknopftafel weiter umfasst:

- ein oder mehrere elastische Silikonbänder (9), die an der inneren Oberfläche des Deckels gesichert sind, die in Korrespondenz mit den Löchern (7) sind, damit sie elastisch an der Basis des einen oder der mehreren Kolben (5) haften und gewährleisten, dass die letzteren elastisch nach der Betätigung in die Ruheposition zurückkehren, wobei ein elastisches Silikonband für jeden Kolben vorhanden ist.

2. Explosionsgeschützte Druckknopftafel für elektrische Fernbedienung über Kabel nach Anspruch 1, umfassend eine oder mehrere Buchsen (13), die als Träger für die Kolben fungieren, eine für jedes der Löcher (7), wobei die Buchsen eine hohle T-Form aufweisen, innerhalb derer ein entsprechender Kolben gleiten kann.

3. Explosionsgeschützte Druckknopftafel für elektrische Fernbedienung über Kabel nach Anspruch 1, wobei die Basis (1) eine Vertiefung (11) unter der Platte (6) aufweist, um mindestens einen Antikondenswiderstand aufzunehmen.

4. Explosionsgeschützte Druckknopftafel für elektrische Fernbedienung über Kabel nach Anspruch 1, wobei die Platte (6) mittels langer Schrauben (16) am Boden der Basis (1) befestigt ist, damit sie einfach eingesetzt, angehoben oder entfernt werden kann, wobei die Länge der Schrauben so ist, dass sie über die Oberkante der Schalter herausragen.

5. Explosionsgeschützte Druckknopftafel für elektrische Fernbedienung über Kabel nach Anspruch 1, wobei die Basis (1) ein seitliches Loch (10) umfasst, das einen Dichtungsring eines in die Basis eindringenden elektrischen Kabels aufnimmt, damit die elektrischen Drähte des Kabels an die jeweiligen elektrischen Schalter angeschlossen werden können.

6. Explosionsgeschützte Druckknopftafel für elektrische Fernbedienung über Kabel nach Anspruch 1, umfassend externe Abdeckungen (14), für den einen oder die mehreren Schalter (7), die an der äußeren Oberfläche des Deckels (2) angebracht sind.

7. Explosionsgeschützte Druckknopftafel für elektrische Fernbedienung über Kabel nach Anspruch 1, wobei die Basis (1) eine gerundete Kontur (12) aufweist.

8. Explosionsgeschützte Druckknopftafel für elektrische Fernbedienung über Kabel nach Anspruch 2, wobei die hohle Basis, der Deckel, die Kolben, die Buchsen aus metallischem Material hergestellt sind.

9. Explosionsgeschützte Druckknopftafel für elektrische Fernbedienung über Kabel nach Anspruch 1, wobei der Deckel auf seiner inneren Umfangskante eine Laminierungsverbindung (20) umfasst, die angepasst ist, um in eine entsprechende Aussparung (21) auf der inneren Umfangskante der hohlen Basis (1) zu passen.

Revendications

1. Panneau à bouton-poussoir antidéflagrant pour une télécommande électrique par câble, comprenant :
- une base creuse (1) et un couvercle (2) ;
 - une carte (6), interne à ladite base creuse (1) ;
 - un ou plusieurs commutateurs électriques ayant des caractéristiques non antidéflagrantes (3), assujettis à ladite carte à l'intérieur de ladite

base creuse (1) ;

- un ou plusieurs cylindres mobiles (4), pour chacun desdits commutateurs électriques (3), à l'intérieur de ladite base creuse (1), lesdits cylindres mobiles (4) étant adaptés pour commander l'ouverture et la fermeture de commutateurs correspondants auxquels ils sont assujettis ;

- un ou plusieurs pistons (5) capables de coulisser à travers des trous (7) correspondants dans ledit couvercle (2), lesdits pistons étant adaptés pour s'enclencher contre des cylindres (4) correspondants et pour être actionnés depuis l'extérieur du panneau à bouton-poussoir, lorsque ce dernier est fermé, pour amener lesdits cylindres à se déplacer ;

- ladite base creuse (1) et ledit couvercle (2) étant adaptés pour former une enceinte en métal opérationnellement fermée ayant des caractéristiques antidéflagrantes ;

caractérisé en ce que le panneau à bouton-poussoir antidéflagrant comprend en outre :

- une ou plusieurs bandes en silicone élastique (9) assujetties à la surface intérieure du couvercle, en correspondance avec lesdits trous (7), de façon à adhérer élastiquement à la base desdits un ou plusieurs pistons (5) et garantir que ces derniers retourneront élastiquement dans la position inactive après l'actionnement, une bande en silicone élastique étant présente pour chaque piston.

2. Panneau à bouton-poussoir antidéflagrant pour une télécommande électrique par câble selon la revendication 1, comprenant une ou plusieurs douilles (13), une pour chacun desdits trous (7), servant de supports pour lesdits pistons, lesdites douilles ayant une forme en T creuse, au sein de laquelle un piston correspondant peut coulisser.

3. Panneau à bouton-poussoir antidéflagrant pour une télécommande électrique par câble selon la revendication 1, dans lequel ladite base (1) comporte une cavité (11) sous ladite carte (6) pour loger au moins une résistance anticondensation.

4. Panneau à bouton-poussoir antidéflagrant pour une télécommande électrique par câble selon la revendication 1, dans lequel ladite carte (6) est fixée au moyen de vis longues (16) au fond de la base (1), de façon à pouvoir être insérée, soulevée ou enlevée facilement, la longueur desdites vis étant telle qu'elles dépassent du bord supérieur des commutateurs.

5. Panneau à bouton-poussoir antidéflagrant pour une télécommande électrique par câble selon la revendication 1, dans lequel la base (1) comprend un trou

latéral (10) qui loge une bague d'étanchéité d'un câble électrique pénétrant dans la base, de sorte que les fils électriques du câble puissent être connectés aux commutateurs électriques respectifs.

6. Panneau à bouton-poussoir antidéflagrant pour une télécommande électrique par câble selon la revendication 1, comprenant des éléments couvrants externes (14) pour lesdits un ou plusieurs commutateurs (7), appliqués à la surface extérieure dudit couvercle (2).

7. Panneau à bouton-poussoir antidéflagrant pour une télécommande électrique par câble selon la revendication 1, dans lequel ladite base (1) a un contour arrondi (12).

8. Panneau à bouton-poussoir antidéflagrant pour une télécommande électrique par câble selon la revendication 2, dans lequel la base creuse, le couvercle, les pistons, les douilles sont réalisés en un matériau métallique.

9. Panneau à bouton-poussoir antidéflagrant pour une télécommande électrique par câble selon la revendication 1, dans lequel ledit couvercle comprend, sur son bord intérieur périmétrique, un joint de lamination (20) adapté pour s'ajuster dans un évidement (21) correspondant sur le bord intérieur périmétrique de ladite base creuse (1).

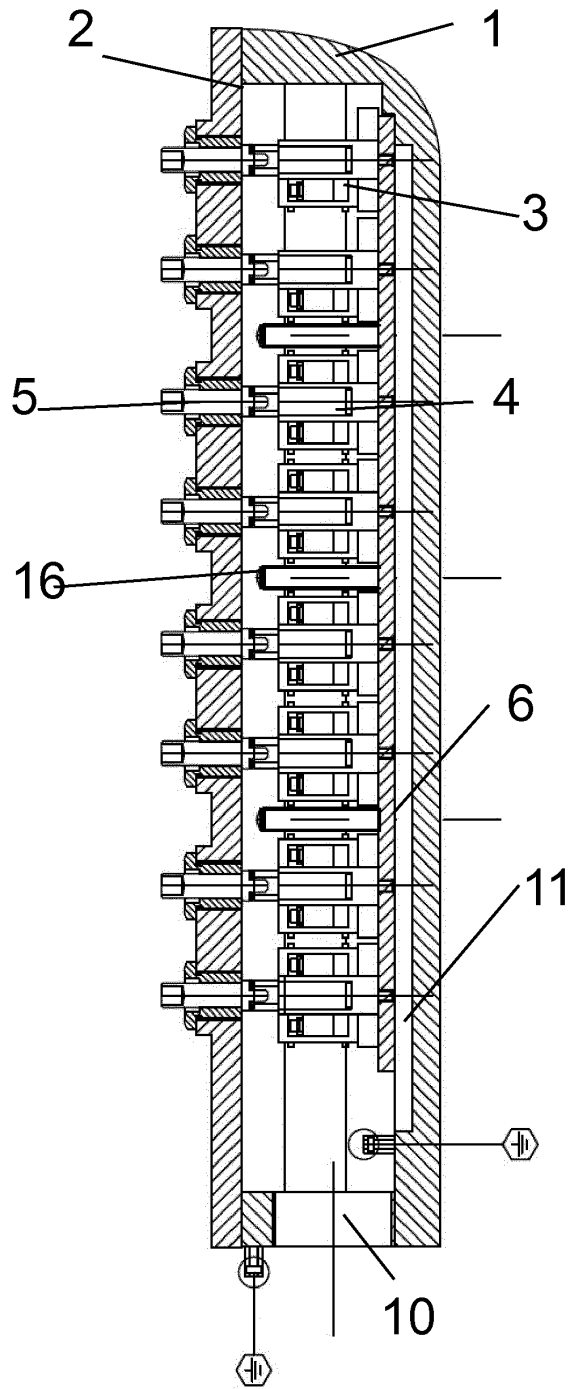

FIG. 1

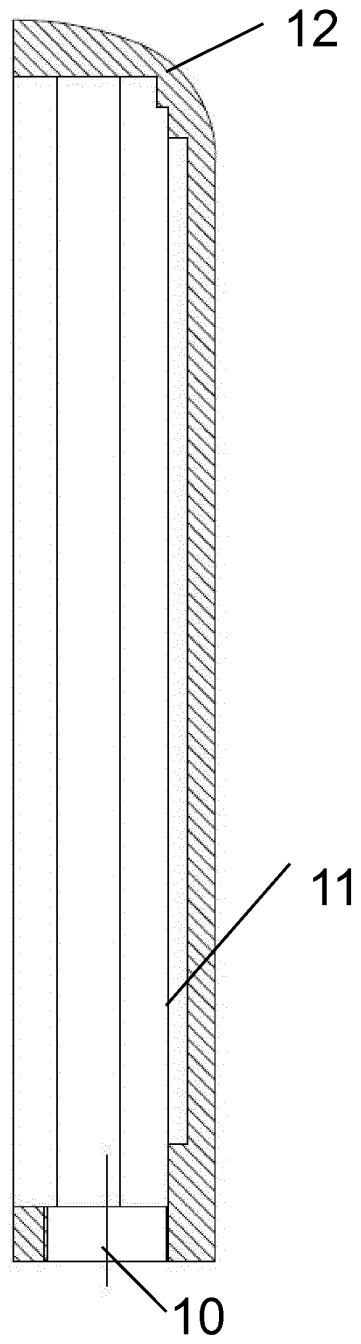
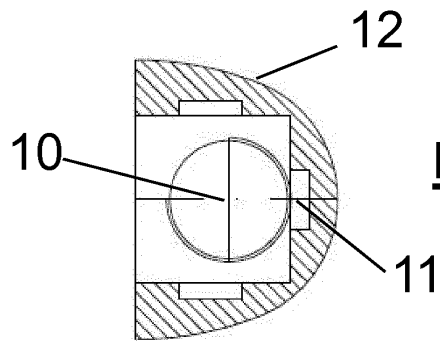

FIG. 2



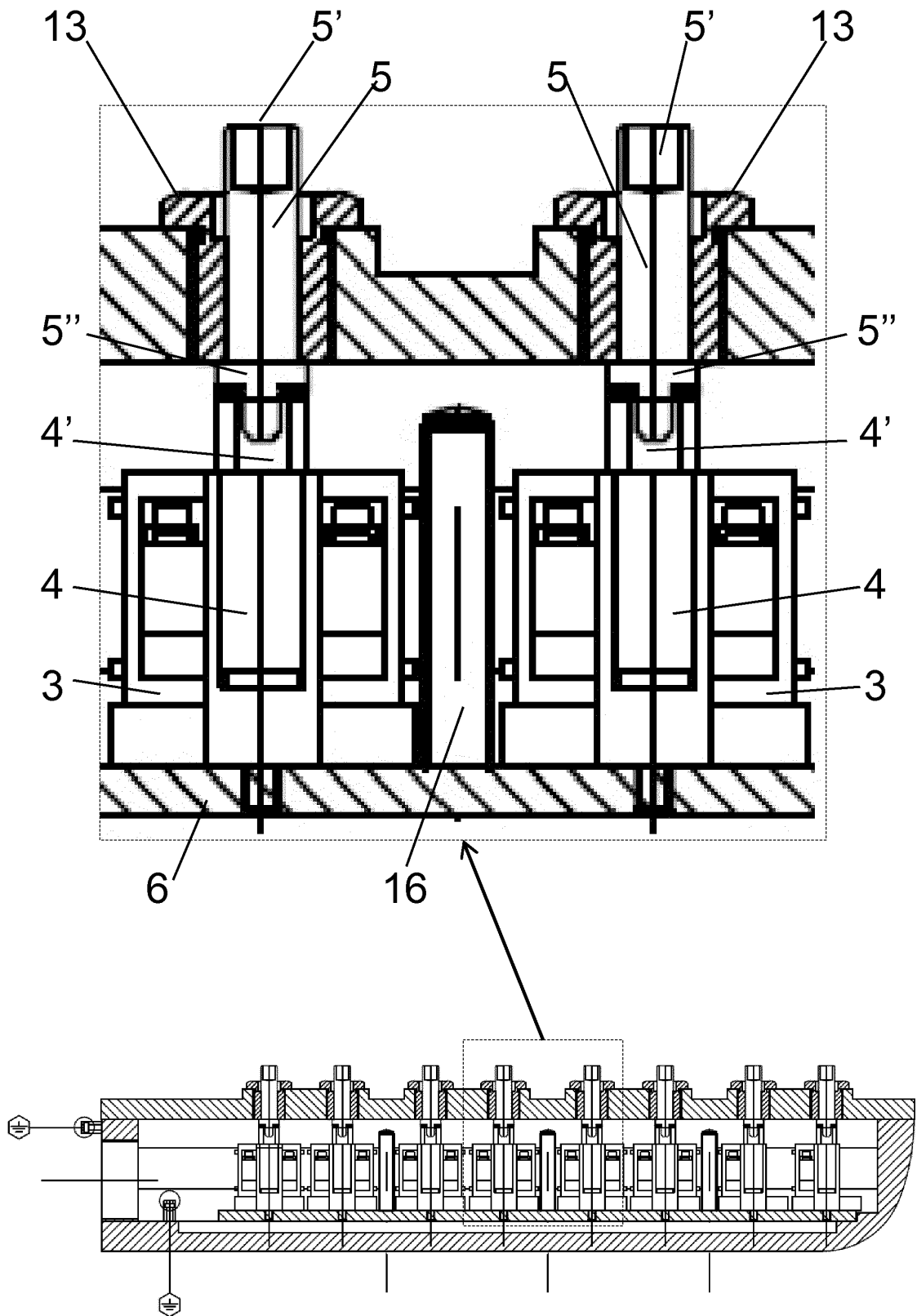

FIG. 3

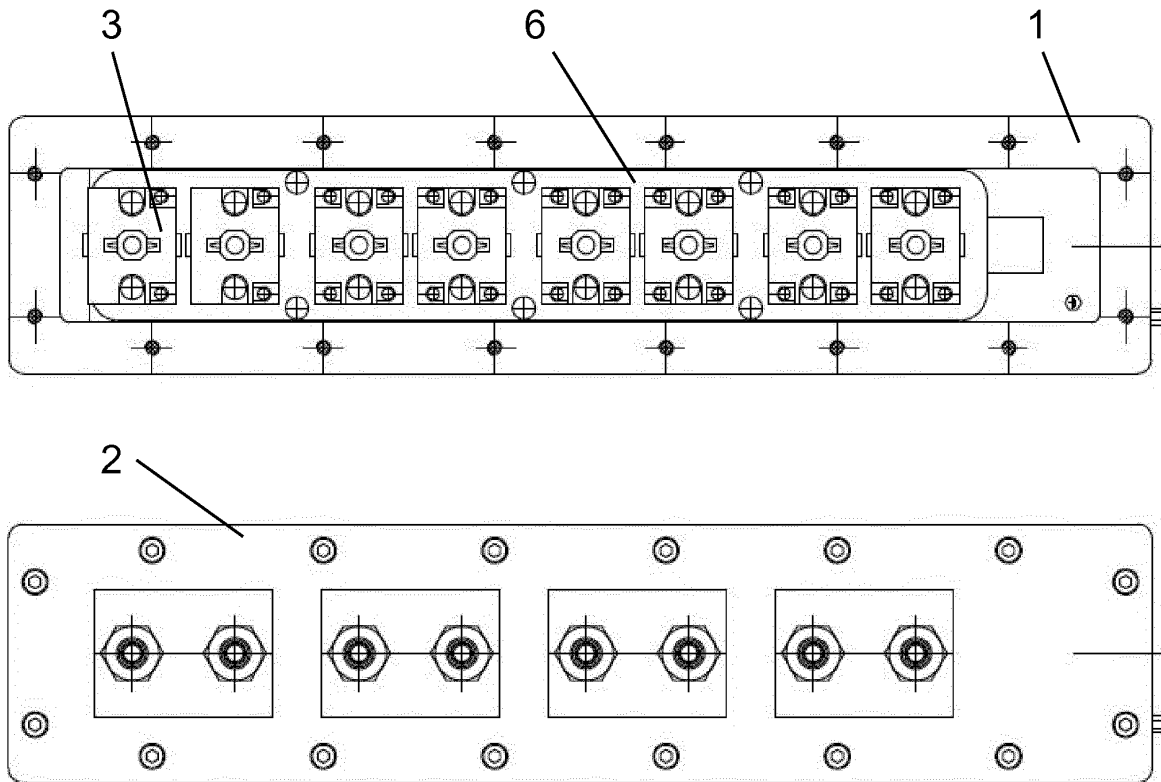

FIG. 4

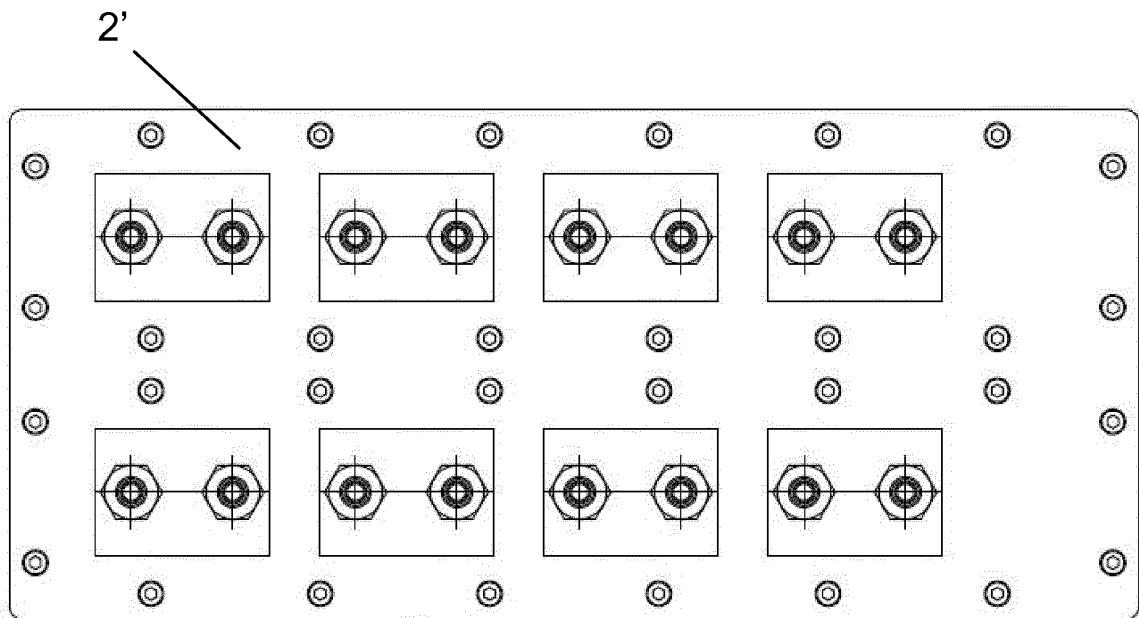

FIG. 5

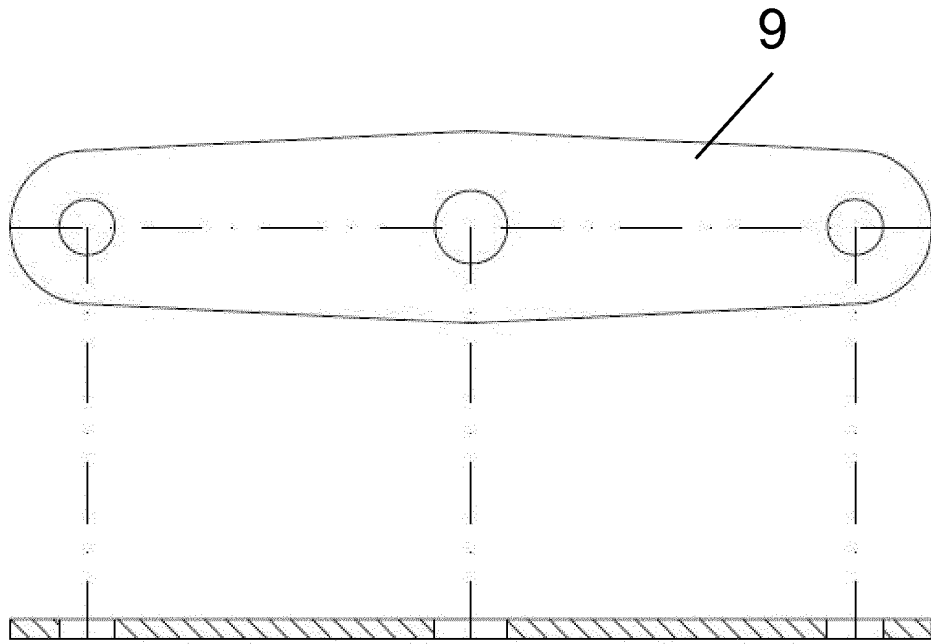

FIG. 6

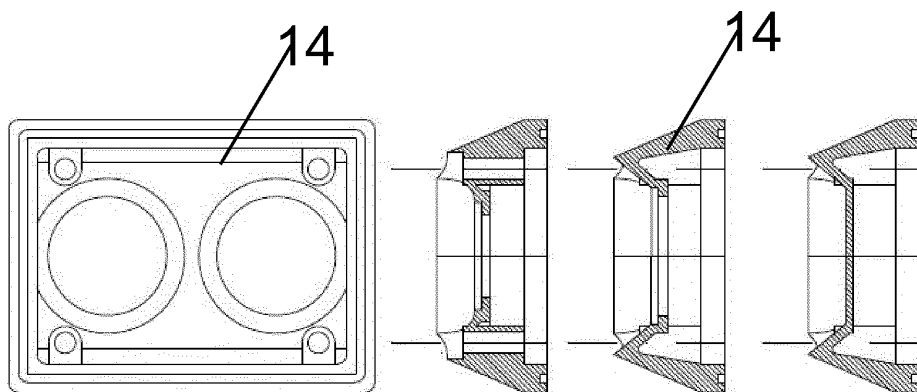

FIG. 7

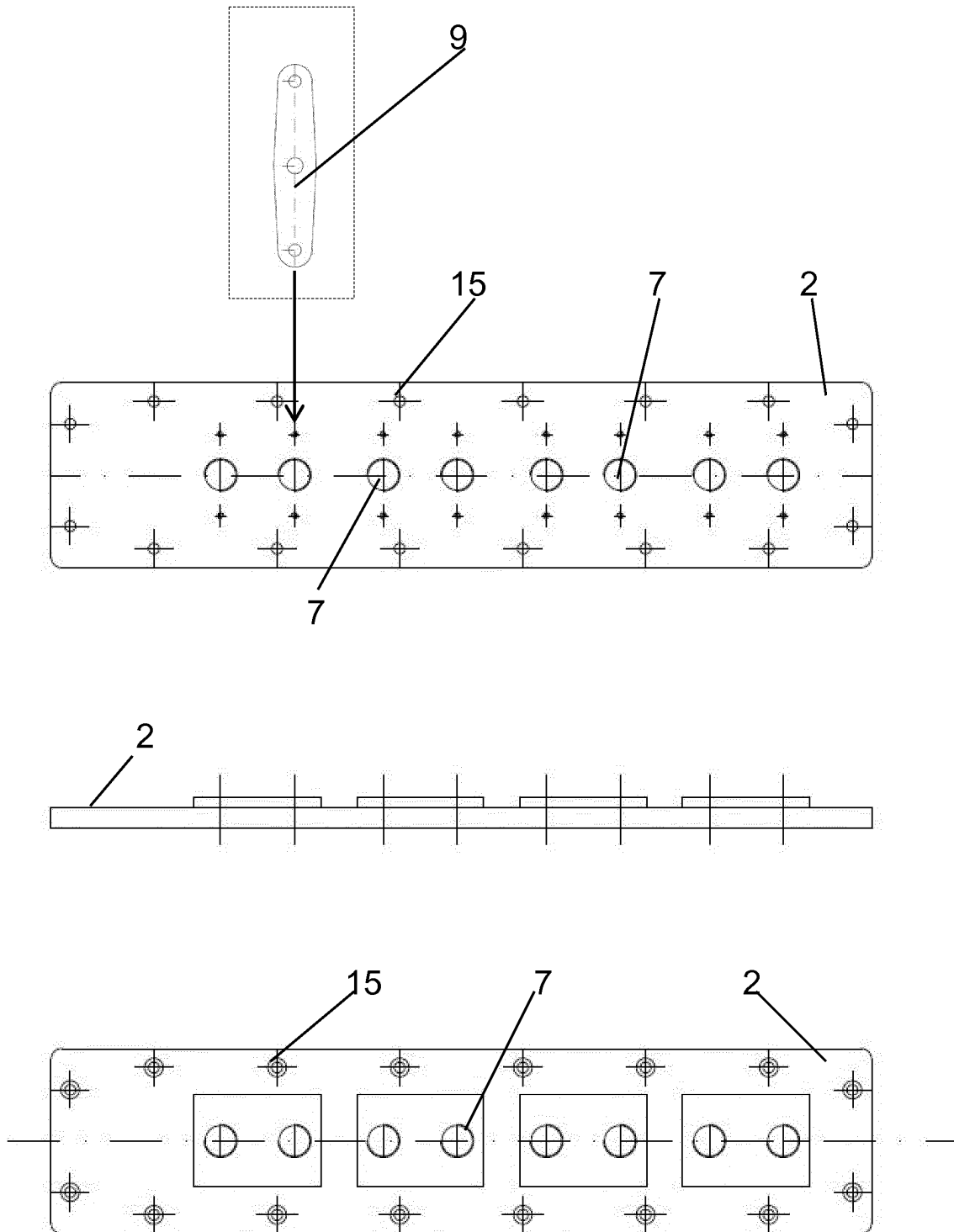

FIG. 8

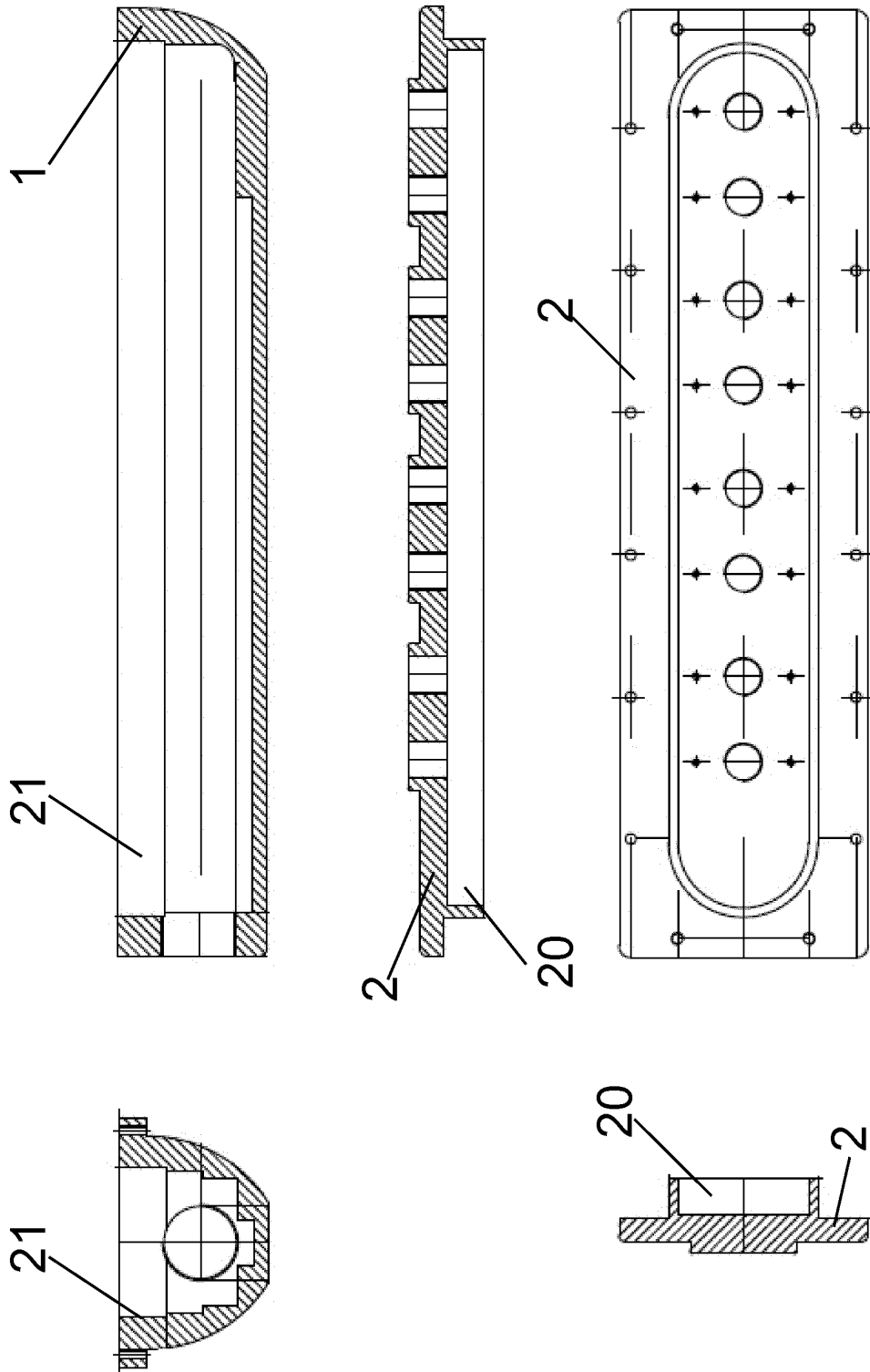

FIG. 9

REFERENCES CITED IN THE DESCRIPTION

This list of references cited by the applicant is for the reader's convenience only. It does not form part of the European patent document. Even though great care has been taken in compiling the references, errors or omissions cannot be excluded and the EPO disclaims all liability in this regard.

Patent documents cited in the description

- US 3236989 A [0006]