



(12) **EUROPEAN PATENT APPLICATION**

(43) Date of publication:
06.12.2017 Bulletin 2017/49

(51) Int Cl.:
E05D 9/00 (2006.01) C23F 13/08 (2006.01)
C23F 13/14 (2006.01) E04D 13/03 (2006.01)
E05D 7/081 (2006.01)

(21) Application number: **17173408.0**

(22) Date of filing: **30.05.2017**

(84) Designated Contracting States:
AL AT BE BG CH CY CZ DE DK EE ES FI FR GB GR HR HU IE IS IT LI LT LU LV MC MK MT NL NO PL PT RO RS SE SI SK SM TR
 Designated Extension States:
BA ME
 Designated Validation States:
MA MD

(71) Applicant: **VKR Holding A/S**
2970 Hørsholm (DK)

(72) Inventor: **MELSEN, Michael**
8632 Lemming (DK)

(74) Representative: **Awapatent A/S**
Strandgade 56
1401 Copenhagen K (DK)

(30) Priority: **31.05.2016 DK PA201670392**

(54) **WINDOW BRACKET ASSEMBLY**

(57) The present invention relates to a window bracket assembly for use in connection with a window, comprising a metal bracket and at least one sacrificial anode, wherein the metal bracket is placed in contact with or in the vicinity of the at least one sacrificial anode and where

the metal bracket and the sacrificial anode has/have one or more mutual connection points, for extending a lifetime of the metal bracket. Furthermore it relates to a window provided with such a window bracket assembly, a kit of parts and use of a window bracket assembly.

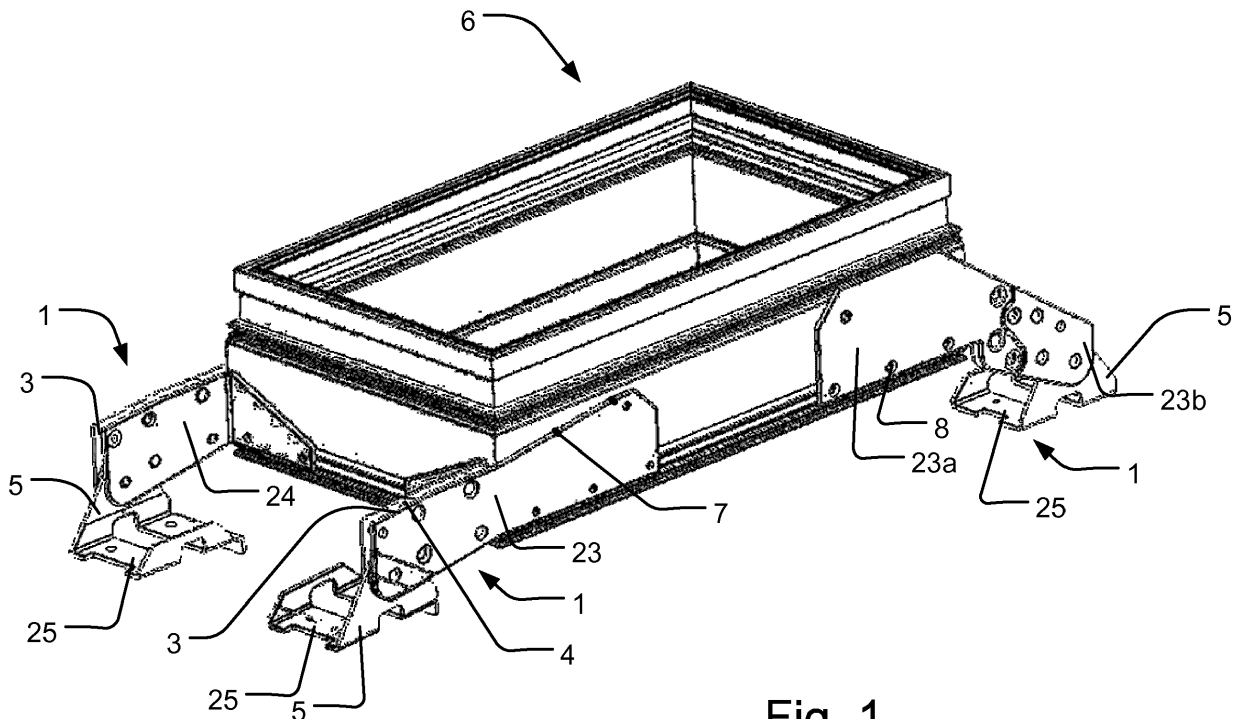

Fig. 1

Description

[0001] The present invention relates to a window bracket assembly for use in connection with a window, comprising a metal bracket and at least one sacrificial anode, use of a window mounting assembly, a kit of parts suitable for use in maintenance of a metal bracket and a window provided with said bracket assembly.

[0002] It is a well known problem that metal construction parts, such as wall ties and steel reinforcement in concrete will corrode over time, and they will eventually need to be repaired or replaced. Corrosion is a chemical process where for example oxygen reacts with a metal such as iron and form iron oxide, a.k.a. rust, particularly in the presence of an electrolyte, such as aqueous saline solutions. In the process electrons are removed from the metal, which then is referred to as the anode, and transferred to a different area, which doesn't corrode and which is referred to as the cathode.

[0003] When it comes to windows and doors, the brackets are traditionally made of steel, but when they are to be used in strongly corrosive environments such as for indoor swimming pools categorized as C4 in the ISO 1461 corrosion category, steel will corrode too quickly in relation to expected lifetime of the window. This is because of the high humidity content and the high content of chlorine/chlorine amines or hydrochloric acid compounds in the air. Small perforations in the vapor barrier may result in chlorine containing vapour building up and condensing on the brackets. Since the brackets are often placed on large windows and may be hidden in the construction, they are hard to replace and other kinds of corrosive treatments need to be applied. In this kind of environment alternative protection are required, but the known methods all have their drawbacks. For example coatings of different kinds, such as aqua and epoxy coating, powder coating, have proven not to be sufficiently scratch resistant and the protective layer may therefore be broken during installation or corrosion will creep under the protective layer. Another example is galvanization or chromate conversion coating; however, the layer required to protect the bracket, and the screws for that matter, would be too thick to make it feasible to manufacture, when it has to resist corrosion for an extended time in a strongly corrosive environment.

[0004] Therefore it is an object of the present invention to provide a solution that can make a metal bracket endure prolonged exposure to a strongly corrosive environment containing humidity and chlorine compounds or other strongly corrosive airborne compounds.

[0005] In one aspect of the invention, this is achieved with a metal bracket being placed in contact with or in the vicinity of at least one sacrificial anode and where the metal bracket and the sacrificial anode has/have one or more mutual connection points, for extending a lifetime of the metal bracket.

[0006] The metal bracket may be used to mounting a roof window, a façade window or any other kind of win-

dow. A bracket is to be understood as any kind of bracket or furniture used on a window or a door for that matter, such as mounting brackets, fasteners, hooks, stays, hinges, closure elements, bearings etc. The window may be fixed or it may be able to open.

[0007] In order for the sacrificial anode to work, an electrolyte is required. The electrolyte may be present because a water vapor barrier is perforated and precipitation seeps into the construction, or the ceiling or wall has not been insulated correctly. The electrolyte may also come from inside the building in the form of water vapor generated in a heated room such as a swimming bath. When the vapor comes in contact with a bracket, which directly, or indirectly through a cold bridge, is in contact with the cooler outside air, the vapor will condense. The condensed vapor is as such free from salts but will try to react with conductive substances in the air such as chlorine compounds thereby forming a conductive fluid. Thereby a strongly corrosive environment will form, but also an environment suitable for use of a sacrificial anode, as a conductive fluid is present. Therefore no external source of power is required and the electrons will move by themselves.

[0008] "In the vicinity of" may be understood as a distance between 0.001 mm and 0.5 mm between the sacrificial anode and the bracket it is intended to protect. The reason for a small distance being possible is that an oxide film will form between the two faces in the presence of an electrolyte, and thereby further corrosive compounds is prevented from depositing between the bracket and the sacrificial anode.

[0009] In the connection point, direct contact may be present but no direct contact is necessary. A distance between the bracket and the sacrificial anode should though not exceed 0.5 mm as electrolytes should still be transferable for example if aqueous saline solutions enter the space between the bracket and the sacrificial anode.

[0010] The one or more connection points may be selected amongst one or more points, one or more faces and/or one or more edges.

[0011] The at least one sacrificial anode placed in contact with or in the vicinity of the bracket and preferably being adapted to the shape and size of the bracket, and/or having a face to face contact may be referred to as a primary sacrificial anode.

[0012] The bracket in the form of a window mounting bracket may comprise a base element adapted to extend in parallel to a first side of a window, a leg element which comprises a first and a second leg. The first leg may be adapted to extend in parallel to a second side of a window perpendicular to the first side of the window, and a second leg which may be adapted to extend in parallel to the base element, and an angle element which may be adapted to be sandwiched between the base element and the leg element.

[0013] In general the number, shape and/or overall design of sacrificial anodes may be adapted to the number, shape and/or overall design of the brackets.

[0014] The thickness of the sacrificial anode may be between 150 μm and 2000 μm , preferably 300 μm and 1000 μm and more preferably between 400 μm and 600 μm , depending on how much the life time of the bracket should be extended. An anode having a thickness of 500 μm and covering the two largest surfaces of the bracket has been found to be advantageous. A protective coating of a thickness between 150 μm and 1000 μm would not be feasible using the above mentioned galvanic or chromate conversion coatings on brackets having the dimensions commonly used for brackets for windows. The thickness of the sacrificial anode may be the same thickness or smaller than the thickness of the bracket or the plate material used for the bracket.

[0015] Likewise the better connection, i.e. area wherein faces of the bracket directly or indirectly touch each other or overlap, the better corrosive protection of the bracket may be provided. An advantage of this kind of protection is that it also protects attachment elements such as screws, rivets or bushings used for attaching the bracket to the window. During mounting of the attachment elements tension cracks may arise in the bracket. In this case the sacrificial anode will also protect this weakened area from corrosion.

[0016] The sacrificial anode is preferably shaped from a plate. This makes it easier to mount as it may be mounted in at the same time as the bracket as the same attachment means as being commonly used, may be used for attaching the sacrificial anode as well. Additionally it may be mounted at a later stage after installation of the window. The thickness of the sacrificial anode may then be understood as the plate thickness of the sacrificial anode. The plate may be perforated.

[0017] It is also possible to employ a number of smaller sacrificial anodes attached to the bracket by means of mechanical attachment such as screws or rivets or by means of an adhesive, by welding or by rolling.

[0018] The sacrificial anode may cover between 10-95% of the surface area of the bracket, preferably 20-80% of the surface area of the bracket, more preferably 30-70% of the surface area of the bracket. By covering a large surface or one or more main surfaces of the bracket, protection is also provided to the nearby surrounding areas such as screws or smaller projections not as such covered by the sacrificial anode.

[0019] The bracket may comprise several bracket elements. A main surface may be defined as one unobstructed surface area, with a general plane surface. Preferably the main surface is the largest surface of a bracket. The main surface which is in contact with the sacrificial anode is preferably a surface that faces a side of the bracket that is adapted to face away from a construction to which the bracket is adapted to be mounted.

[0020] In a further embodiment the sacrificial anode comprises at least one of zinc, magnesium and aluminum. Zinc would be the preferred material. Magnesium, being less noble than zinc, may also be used. It will corrode at a faster pace than zinc, but the deposits will slow

down the corrosion over all. In order for the sacrificial anode to work it has to be of a metal, which is less noble than the metal used for the bracket. Thereby the electrons can be transferred when an electrolyte like aqueous saline solutions is present. The metals relative nobility can be found in electrochemical series or galvanic series. The galvanic series for stagnant seawater may be used as reference. The sacrificial anode may also be made of aluminum alloy, if the bracket is made of a different more noble metal or alloy such as steel.

[0021] The metal bracket for windows typically have a plate thickness of 5 mm or less, preferably between 2 and 4 mm, more preferably between 2.5 mm and 3.5 mm. The metal bracket may comprise several elements bent into different shapes and fastened to each other in a suitable way.

[0022] The bracket will often be made mainly of steel or iron or other iron based alloys, preferably carbon steel or carbon iron. The sacrificial anode cannot in the latter case be made of iron as well, but must instead be of zinc or a different metal positioned lower in the electrochemical series or galvanic series than the metal for the bracket may be used instead.

[0023] In a specific embodiment the sacrificial anode is integrated with at least a part of the bracket. The two materials may be rolled together prior to shaping or bending of the bracket or in other ways attached to each other. No matter if the bracket and the sacrificial anode is integrated or not, the two elements form part of the window bracket assembly.

[0024] The sacrificial anode may be positioned lower in the electrochemical series or galvanic series than the metal bracket. This facilitates movement of the ions.

[0025] The metal bracket may of course still be provided with a protective coating, such as a zinc coating and/or a chromate conversion coating. This coating is usually in the range of 30 - 65 μm . This also extends the lifetime of the bracket, by delaying corrosion and hence extending the time before the deterioration of the sacrificial anode sets in. The bracket may also be painted as a form of protection.

[0026] The metal bracket may have a silica content of 0.2-0.35 % when made of steel. The metal bracket may for coating purposes have a surface roughness of at least R_a 12 $\frac{1}{2}$ μm .

[0027] The bracket and/or the sacrificial anode may be provided with at least one attachment member for interconnection. This makes it easier to connect the two metal elements to each other. The attachment member may be in the form of a snap closure or resilient members on the sacrificial anode, making it possible to grip around a part of the bracket. This is particular practical when retrofitting the sacrificial anode on a bracket on an already installed window, for example in connection with performing maintenance.

[0028] A surface geometry of the sacrificial anode may be following at least partly a surface geometry of the metal bracket in a mounted state. That means that if the

bracket has projections or indentations, the sacrificial anode may have corresponding indentations or projections. This provides for a comparatively large area of contact between the bracket and the sacrificial anode, and thereby better corrosion protection of the bracket.

[0029] In an advantageous embodiment the metal bracket comprises a main surface and adjacent edges, and the sacrificial anode substantially covers the main surface and/or the adjacent edges. The metal bracket may comprise several bracket elements, each comprising a main surface. The main surface is usually the largest plane surface of the bracket element. The main surface is usually facing away from the construction, to which the bracket is configured to be fastened to. The sacrificial anode may be shaped like a tray, partly surrounding a part of the bracket, for example a bracket element such as the base element or the leg element of a window bracket as described above.

[0030] The sacrificial anode may be positioned on a cold side of the metal bracket. That is the side configured to be the colder side when the bracket is in place on the mounted window. When the sacrificial anode is placed on the cold side of the metal bracket, which likely is the surface facing away from the construction or window, vapor will more likely condense here, resulting in a better connection between the sacrificial anode and bracket and thereby easier transfer of electrons and consequently better corrosion protection.

[0031] In a further other aspect of the invention, the window bracket assembly is used in connection with a window, preferably a roof window or a facade window.

[0032] In a third aspect of the invention, the sacrificial anode and at least one associated attachment element, such as a screw, for the attachment of the window bracket assembly to a window is provided in a kit of parts for use for maintenance of the metal bracket.

[0033] In a fourth aspect of the invention a window is provided with the window bracket assembly.

[0034] In a preferred embodiment the window is placed in connection with a secondary sacrificial anode extending in one or more directions from a frame of the window and is placed in connection with the window bracket assembly in one or more connection points.

[0035] A secondary sacrificial anode may be established as a secondary part of a vapor barrier assembly. The vapor barrier assembly is usually placed at an interior side of the insulation of a building construction. The vapor barrier assembly comprises either a flexible member, e.g. a rubber or a plastic foil, or a rigid member, such as a board that may be treated with a vapor retarder. An adhering member may be used for fastening the vapor barrier to the window or to other construction parts in the building.

[0036] By providing a secondary sacrificial anode in parallel to or as a part of the vapor barrier, humid air which may pass through unintended holes in the vapor barrier will condense on the secondary sacrificial anode, which then then will be able to protect surrounding metal

elements including window brackets. The secondary sacrificial anode may be provided or used independently of the primary sacrificial anode. The secondary sacrificial anode may be made of zinc, aluminum or magnesium, or alloys comprising one or more of said materials.

[0037] In general the physical and chemical characteristics that apply to the material of the primary sacrificial anode, applies to the secondary sacrificial anode as well, but they need not be made of the same material.

[0038] Further embodiments and advantages are set forth in the dependent claims.

[0039] In the following the invention will be described in further detail by means of examples of embodiments with reference to the schematic drawings, in which

fig. 1 shows a window provided with a window bracket assembly in each of its corners.

Fig. 2 shows the same brackets with sacrificial anodes, however the window has been hidden and further details of the window mounting assembly can be seen.

Fig. 3 shows a different embodiment of the bracket assembly with sacrificial anodes, where the brackets are configured to be placed on an openable window.

Fig. 4 shows a cross section of a roof structure provided with an embodiment of the secondary sacrificial anode.

[0040] A window with a bracket assembly according to the invention comprising a metal bracket and a sacrificial anode is shown in Fig. 1 and the bracket assemblies are shown alone in Fig. 2

[0041] A bracket assembly is provided at each of the corners of the window and is denoted 1 a, 1 b, 1 c and 1 d respectively. Each of the window bracket assemblies 1a-1d comprises a bracket and a sacrificial anode 23, 24, 25. The metal bracket comprises several bracket elements, i.e. a base element 3 provided with sacrificial anode 23, a leg element 4 provided with sacrificial anode 24 and an angle element 5 provided with sacrificial anode 25. The base element 3 is placed in parallel to one leg of the leg element 4. The angle element 5 is partly sandwiched between the base element 3 and the leg element 4. Both the leg element 4 and the base element 3 are attached to a frame part of a window 6.

[0042] The sacrificial anodes 23, 24 have the same circumferential shapes as the base element 3 and the leg element 4, respectively, and each cover a main surface of the metal bracket. The sacrificial anode 24 covering the leg element 4 is also following its surface geometry as it is also bent in an angle. The sacrificial anode 23 covering the base element 3 on bracket assembly 1 c and 1d is not completely following the surface geometry of the base element 3. As a part of the surface of the base element 3 is displaced in the plane, surface contact is only partly obtained. In an alternative embodiment the sacrificial anode 23 may be shaped such that it follows the surface geometry of a surface of the bracket.

[0043] The base elements 3 in 1 a and 1 b are divided in two, and likewise is the sacrificial anodes 23a, 23b. The sacrificial anode 25 has also been divided in two as the surface is interrupted by a projection.

[0044] A thickness t of the sacrificial anode has also been shown, but has been made larger for illustrative purposes. The thickness of the plate for the sacrificial anode used in this embodiment is 0.5 mm, corresponding to 1/6 of the thickness of the base element 3 of the bracket. Different thicknesses may be used as well, depending amongst other things on which environment they are to be used in and on the materials used for the bracket and the anode.

[0045] The sacrificial anodes 23, 24, 25 are provided with through going holes in the same places as the bracket elements 3, 4, 5. This makes it possible to attach the sacrificial anodes 23, 24, 25 to the bracket elements 3, 4, 5 in the same working operation as the attachment of the bracket elements or bracket to the construction or window as the same attachment means, such as screws 8, may fasten both the bracket 3, 4, 5 and the sacrificial anode 23, 24, 25 to the construction, window 6 or a neighbouring bracket.

[0046] The thickness t_p , is the thickness of the plate material used for the bracket. In this embodiment it is 3 mm, but it may be thicker or thinner.

[0047] In fig. 1 the sacrificial anode 23 is provided with attachment members 7 that grip around the base element 3. These attachment members 7 may be dispensed with and the sacrificial anode may be attached to the bracket in the same step as when the bracket is attached to the window frame part. The sacrificial anode may be tray shaped and cover the edges of the bracket elements as well.

[0048] The window 6 and the window bracket assembly 1 shown in Figs 1 and 2 are suitable for being used in a ridge constellation, where two windows meet top-to-top, the tops of the windows resting on a ridge beam extending in parallel with the ridge and with the bottoms resting on opposite wall or façade elements, or in the case of installation on substantially flat roofs, on opposite upstands.

[0049] Fig. 3 shows a different embodiment of a bracket assembly 1a-1f, configured to be used on an openable window. The brackets assemblies 1 a, 1 b, 1 c, 1 d are configured to be positioned on a window frame in substantially the same way as in Fig 1, while the bracket assemblies 1e, 1f, 1g comprising the brackets 9, 30 are configured to be positioned on a sash of a window and are all provided with sacrificial anodes 29, 20. It will, however, be understood that it is not necessary to provide all brackets, associated with a window, with sacrificial anodes in order to achieve an advantageous effect.

[0050] A difference between the embodiments in Figs 2 and 3 is that the sacrificial anode 23c is configured to be positioned on a different embodiment of the bracket 3 in Fig. 3.

[0051] Fig. 4 shows a cross section of a roof structure

40, provided with a window 6, a flashing element 42 and insulation 43. The window comprises a frame 44 and a bracket 3 resting on a beam of a load bearing structure. Between the bracket 3 and the frame 44 a secondary sacrificial anode 45 is positioned. The secondary sacrificial anode 45 is in the form of a plate, but it may be in the form of a film or foil as well. By spanning the gap between the frame 44 of the window and the load-bearing structure is serves as a vapour barrier, which prevent or hinders hot air with a high moisture content from within the building in reaching the bracket 3.

[0052] In general, the features of the embodiments shown and described may be combined freely and no feature should be seen as essential unless stated in the independent claims.

[0053] The invention should not be regarded as being limited to the embodiments shown in the drawings and described in the above. Various modifications and combinations may be carried out within the scope of the appended claims.

Claims

1. Window bracket assembly for use in connection with a window, comprising a metal bracket and at least one sacrificial anode, **characterized** in that the metal bracket is placed in contact with or in the vicinity of the at least one sacrificial anode and where the metal bracket and the sacrificial anode has/have one or more mutual connection points, for extending a lifetime of the metal bracket.
2. Window bracket assembly according to claim 1, wherein the sacrificial anode has a thickness between 150 μm and 2000 μm , preferably between 300 μm and 1000 μm and more preferably between 400 μm and 600 μm .
3. Window bracket assembly according to claim 1 or 2, wherein the metal bracket has a plate thickness of 5 mm or less, preferably between 2 and 4 mm, more preferably between 2.5 mm and 3.5 mm.
4. Window bracket assembly according to any one of the preceding claims, wherein the sacrificial anode covers between 10-95% of the surface area of the metal bracket, preferably 20-80% of surface area of the metal bracket, more preferably 30-70% of the surface area of the metal bracket.
5. Window bracket assembly according to any one of the preceding claims, wherein the sacrificial anode comprises at least one of zinc, magnesium and aluminum.
6. Window bracket assembly according to any one of the preceding claims, wherein the metal bracket is

mainly made of steel or iron or other iron based alloys, preferably carbon steel or carbon iron.

7. Window bracket assembly according to any one of the preceding claims, wherein the sacrificial anode is integrated with at least a part of the metal bracket. 5
8. Window bracket assembly according to any one of the preceding claims, wherein the sacrificial anode is positioned lower in the galvanic series than the metal bracket. 10
9. Window bracket assembly according to any one of the preceding claims, wherein the metal bracket is provided with a protective coating, such as a zinc coating and/or a chromate conversion coating. 15
10. Window bracket assembly according to any one of the preceding claims, wherein the metal bracket and/or the sacrificial anode is provided with at least one attachment member for interconnection. 20
11. Window bracket assembly according to any one of the preceding claims, wherein a surface geometry of the sacrificial anode is following at least partly a surface geometry of the metal bracket in a mounted state. 25
12. Window bracket assembly according to any one of the preceding claims, wherein the metal bracket comprises a main surface and adjacent edges, and wherein the sacrificial anode substantially covers the main surface and/or the adjacent edges. 30
13. Window bracket assembly according to any one of the preceding claims, wherein the sacrificial anode is positioned on the side configured to be a cold side of the metal bracket. 35
14. Use of window bracket assembly according to any one of the preceding claims in connection with a window, preferably a roof window. 40
15. Kit of parts suitable for use of maintenance of a metal bracket, comprising a sacrificial anode according to any one of claims 1-13 and at least one attachment element, such as a screw, for the attachment of the sacrificial anode. 45
16. Window provided with a window bracket assembly according to any one of claims 1-13. 50
17. Window according to claim 16 placed in connection with a secondary sacrificial anode extending in one or more directions from a frame of the window and is placed in connection with the window bracket assembly in one or more connection points. 55

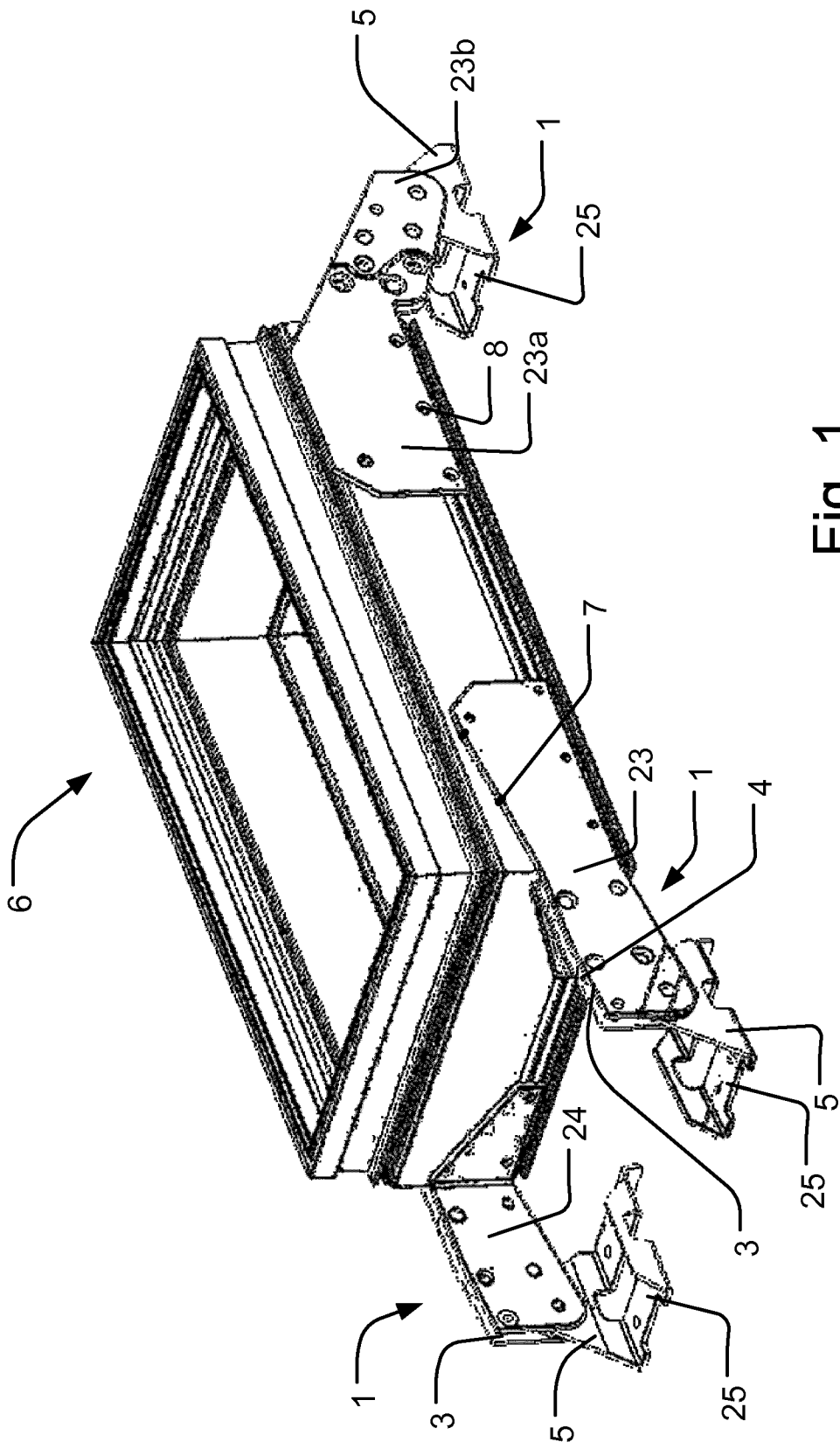

Fig. 1

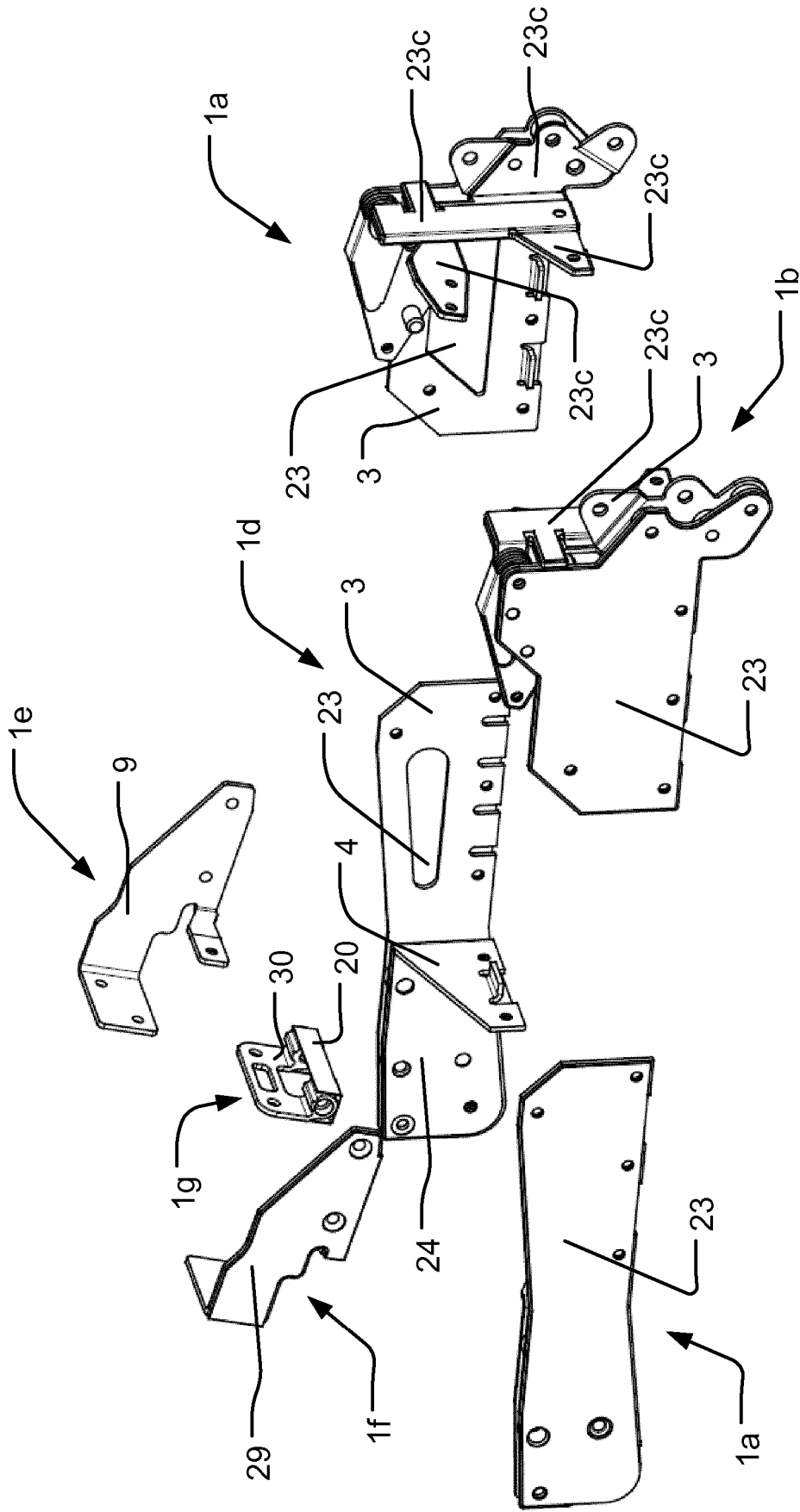

Fig. 3

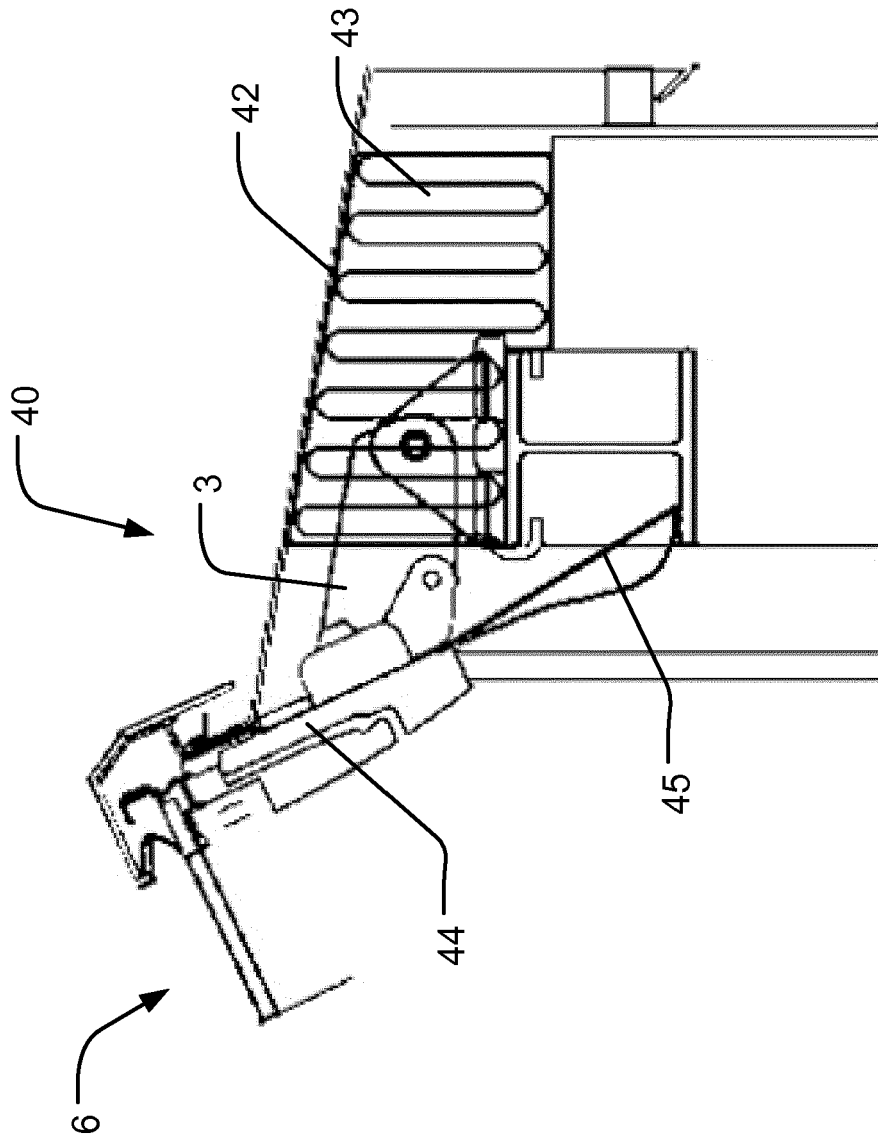

Fig. 4



EUROPEAN SEARCH REPORT

Application Number
EP 17 17 3408

5

10

15

20

25

30

35

40

45

50

55

DOCUMENTS CONSIDERED TO BE RELEVANT			
Category	Citation of document with indication, where appropriate, of relevant passages	Relevant to claim	CLASSIFICATION OF THE APPLICATION (IPC)
X	JP S61 237788 A (SHINKO ARUFURETSUSHIYU KK) 23 October 1986 (1986-10-23) * page 1 - page 4; figures 1-6 * -----	1-17	INV. E05D9/00 C23F13/08 C23F13/14 E04D13/03
X	CN 104 533 202 A (CHANGSHU BAOCHENG HARDWARE PRODUCTS CO LTD) 22 April 2015 (2015-04-22) * paragraph [0006] - paragraph [0018] * -----	1,4,5,9	ADD. E05D7/081
A	US 8 562 310 B1 (RAWLINGS DAVID [US]) 22 October 2013 (2013-10-22) * column 2, line 37 - line 41 * * column 13, line 7 - line 46 * * column 13, line 63 - column 14, line 3 * -----	1	
A	JP 3 849106 B2 (TANITA HOUSINGWARE CO LTD) 22 November 2006 (2006-11-22) * paragraph [0016] - paragraph [0028]; figures 1-4 * -----	2,4,14	
			TECHNICAL FIELDS SEARCHED (IPC)
			E05D C23F E04D E06B
The present search report has been drawn up for all claims			
Place of search The Hague		Date of completion of the search 16 October 2017	Examiner Rémondot, Xavier
CATEGORY OF CITED DOCUMENTS X : particularly relevant if taken alone Y : particularly relevant if combined with another document of the same category A : technological background O : non-written disclosure P : intermediate document		T : theory or principle underlying the invention E : earlier patent document, but published on, or after the filing date D : document cited in the application L : document cited for other reasons & : member of the same patent family, corresponding document	

EPO FORM 1503 03/02 (P04C01)

**ANNEX TO THE EUROPEAN SEARCH REPORT
ON EUROPEAN PATENT APPLICATION NO.**

EP 17 17 3408

5 This annex lists the patent family members relating to the patent documents cited in the above-mentioned European search report.
The members are as contained in the European Patent Office EDP file on
The European Patent Office is in no way liable for these particulars which are merely given for the purpose of information.

16-10-2017

Patent document cited in search report	Publication date	Patent family member(s)	Publication date
JP S61237788 A	23-10-1986	NONE	

CN 104533202 A	22-04-2015	NONE	

US 8562310 B1	22-10-2013	US 8562310 B1	22-10-2013
		US 2014017103 A1	16-01-2014
		US 2016305412 A1	20-10-2016

JP 3849106 B2	22-11-2006	JP 3849106 B2	22-11-2006
		JP H10245951 A	14-09-1998

EPO FORM P0459

For more details about this annex : see Official Journal of the European Patent Office, No. 12/82