



(11) **EP 3 255 220 B1**

(12) **EUROPEAN PATENT SPECIFICATION**

(45) Date of publication and mention of the grant of the patent:
19.12.2018 Bulletin 2018/51

(51) Int Cl.:
E04D 13/17^(2006.01)

(21) Application number: **17175017.7**

(22) Date of filing: **08.06.2017**

(54) **A VENTILATED RIDGE FOR BUILDINGS**

BELÜFTETER FIRST FÜR GEBÄUDE

FAITAGE VENTILÉ POUR BÂTIMENTS

(84) Designated Contracting States:
AL AT BE BG CH CY CZ DE DK EE ES FI FR GB GR HR HU IE IS IT LI LT LU LV MC MK MT NL NO PL PT RO RS SE SI SK SM TR

(30) Priority: **09.06.2016 IT UA20164231**

(43) Date of publication of application:
13.12.2017 Bulletin 2017/50

(73) Proprietor: **MAZZONETTO S.P.A.**
35010 Loreggia (PD) (IT)

(72) Inventors:
• **MAZZONETTO, GIUSEPPE**
35010 LOREGGIA (PADOVA) (IT)
• **MAZZONETTO, JACOPO**
35010 LOREGGIA (PADOVA) (IT)
• **BERALDO, FABIO**
35010 LOREGGIA (PADOVA) (IT)

• **ZANIN, FEDERICO**
35010 LOREGGIA (PADOVA) (IT)

(74) Representative: **Piovesana, Paolo**
Via F. Baracca, 5/a
30173 Venezia-Mestre (IT)

(56) References cited:
DE-A1- 1 609 951 **FR-A1- 2 399 515**
FR-A1- 2 654 138 **FR-A1- 2 877 026**
FR-A1- 2 915 499 **US-A1- 2004 128 920**
US-A1- 2009 272 064

• **FARHI E: "avis sur le fa^À TM tage ^À ventilation continue PVM 800", CAHIERS DU CENTRE SCIENTIFIQUE ET TECHNIQUE DU BÂTIMENT,, no. 228, 1 April 1982 (1982-04-01), XP001475822,**

EP 3 255 220 B1

Note: Within nine months of the publication of the mention of the grant of the European patent in the European Patent Bulletin, any person may give notice to the European Patent Office of opposition to that patent, in accordance with the Implementing Regulations. Notice of opposition shall not be deemed to have been filed until the opposition fee has been paid. (Art. 99(1) European Patent Convention).

Description

[0001] The present invention relates to a ventilated ridge for buildings.

[0002] Ventilated ridges for buildings, i.e. products to be applied on the roof covering of a building on the top of two flat pitches which either inclined or curved in opposite sense, are known. In general, the ventilated ridges comprise metal brackets or wooden boards, which are fixed to the structure underneath the roofing before a perforated ventilation sheet (mesh) is applied to them, to which the ridge cap is then applied.

[0003] The drawback of this known solution is in that it is the result of a rather handmade activity, to be performed on site requiring a long time, with given inaccuracy of execution, with high costs and with often unsatisfactory results. The fact that the construction is performed on site also poses problems related to the difficulty of controlling the work performed by the operator by personnel in charge.

[0004] In order to eliminate these drawbacks, prefabricated ventilated ridges have been suggested, which comprise a perforated support, which is made of metal sheet and is intended to be fixed to the two pitches of a roof covering, and a ridge cap, which is applied onto the perforated support, generally by means of rivets. A solution of this type is described for example in FR 2399515.

[0005] Another ventilated ridge is known from the "Cahier du CSTB n°1769 Livraison 228" of April 1982, by E. FARHI, with the title "avis sur le façitage a ventilation continue PVM 800".

[0006] This solution can be made entirely off site, and therefore using controllable and reliable industrial processes, and makes it possible to practically overcome all the drawbacks which are found in the prior handmade art; at the same time, it has a number of drawbacks, and in particular:

- the fixing of the perforated support to the ridges of the roof covering is a sometimes uncertain and inaccurate operation and variable on a case-by-case basis; furthermore, two pitches must be provided to receive the perforated support;
- the fixing of the perforated support to the roof covering pitches is often weak and precarious, and thus not very reliable;
- the ridge cap is generally fixed to the perforated support by means of rivets, which are in sight and which often imply an unsatisfactory result in terms of appearance.

[0007] It is the object of the invention to eliminate all these drawbacks and to suggest a ventilated ridge which can be fixed to the pitches of the roof covering rapidly and accurately, without requiring any arrangement of the pitches to receive the perforated support of the ridge.

[0008] It is another object of the invention to suggest a ventilated ridge which can be fixed safely and reliably

to the roof covering pitches.

[0009] It is another object of the invention to suggest a ventilated ridge which uses means for fixing the ridge cap to the perforated support which are not visible from the outside.

[0010] It is another object of the invention to suggest a ventilated ridge with an alternative characterization, in terms of construction, function and performance, with respect to the traditional ones.

[0011] It is another object of the invention to make a ventilated ridge which is simple, quick and easy to obtain.

[0012] All these objects, taken individually or in any combination thereof, and others which will be apparent from the following description, are achieved, according to the invention, by a ventilated ridge having the features indicated in claim 1.

[0013] The present invention is further explained by means of a preferred embodiment given by way of non-limiting practical example only with reference to the accompanying drawings, in which:

Figure 1 shows a cross section of a ventilated ridge according to the invention, and

Figure 2 shows it according to a partially sections perspective view.

[0014] As shown in the figures, the ventilated ridge according to the invention substantially comprises three distinct components 2, 4, 6.

[0015] The first component 2 of the ventilated ridge according to the invention consists of a bracket, of which an appropriate number is used according to the particular installation needs. Preferably, it consists of a flat band of metal sheet, having preferably constant width and thickness and length suited to use practically in all practical cases.

[0016] Advantageously, each bracket 2 is divided lengthwise into three parts, of which the two ends 8 are intended to anchor the bracket itself to the supporting structure of the roofing, in particular to its boards 12, which are applied to the beams 14 underneath arranged corresponding to the shape of the pitches of the covering concerned by the application of the ventilated ridge.

[0017] Advantageously, there is a series of aligned slots defining two facilitated folding lines of the bracket itself at them between the two end portions 8 of each bracket 2 and the central portion 10.

[0018] Furthermore, the two end parts 8 of each bracket 2 are appropriately provided with a plurality of passage holes of screws 16 intended to fix the bracket itself to the boards 12 of the roofing.

[0019] As mentioned, the number of brackets 2 is envisaged according to the assembly needs of the ventilated ridge and are arranged at predetermined fixed distances, e.g. at approximately one meter from one another.

[0020] The second component 4 of the ventilated ridge

according to the invention consists of a perforated sheet support, intended to be fixed to the brackets 2, after these have been constrained on site.

[0021] The support 4 preferably consists of a single sheet which is variably and appropriately folded according to lines parallel to the development direction of the support itself. In particular, the support 4 comprises a U-shaped portion 18 and folded side portions, which are indicated by reference numeral 21 as a whole.

[0022] In particular, the portion 18 comprises a central wing 20, which is appropriately provided with a plurality of ventilation openings 22, and two side wings 24, which are appropriately provided with a plurality of ventilation openings 26.

[0023] The folded side portions 21 of the support 4 comprise:

- two first bands 23, which run from the respective upper ends of the side wings 24 of the U-shaped element 18 and which develop downwards,
- two second bands 25, which run from the respective ends of the first bands 23 and which substantially develop outwards with respect to the latter,
- two third bands 27, which run from the respective ends of the second bands 25 and which substantially develop downwards with respect to the latter.

[0024] Preferably, the upper ends of the side walls 24 of the portion 18 are folded by approximately 180° downwards to define the first bands 23, which run for a given stretch parallel and externally in contact with the side wings themselves and then form the second side bands 25, which run outwards, substantially horizontally and end in the third bands 27, which are folded downwards, in turn, to form an angle of approximately 45° with the second bands 25.

[0025] Advantageously, the third bands 27 end with fourth bands 29 which are folded further downwards so as to be arranged vertically.

[0026] Appropriately, the longitudinal bands of the side wings 24 and/or of the first bands 23, which are preferably folded by about 180° downwards and in contact with the side wings 24, and/or the second side bands 25, which are preferably folded by approximately 90° outwards, are concerned by other ventilation openings 26. Appropriately, the ventilation openings 26 defined in the longitudinal bands of the wide wings 24 of the portion 18 face the ventilation openings 26 defined in the first bands 23.

[0027] The perforated sheet support 4 is intended to be fixed to the brackets 2 by means of self-tapping screws 28, which engage the central wing 20 of the support 4 and the central portion 10 of each bracket 2.

[0028] A third component 6 of the ventilated ridge according to the invention consists of a ridge cap. Appropriately, it consists of a metal profile divided transversally into flat bands, which convey the required shape to the cap and which appropriately comprise:

- a upper central closing band 30 of the U-shaped portion 18 of the perforated support 4,
- two side bands 32 extending the central band 30 and preferably inclined according to the third bands 27 inclined towards the bottom of said perforated support 4, and
- two edges folded firstly vertically and then inwards and upwards to form a sort of coupling edges 34 underneath the third bands 27 and/or the fourth bands 29 of the perforated support 4.

[0029] Advantageously, the side bands 32 of the ridge cap 6 rest on the outer surface of the third bands 27 of the perforated support 4.

[0030] The installation of the ventilated ridge according to the invention firstly requires arranging a fixing the brackets 2 to the boards 12, which form the two flat pitches of the roofing. The brackets 2 are arranged by folding the two end portions 8 of each bracket 2 with respect to the corresponding central portion 10 according to the gradient of the two pitches of the roofing of the building, in case of roofing with flat inclined pitches; or by curving the two end portions of each bracket 2 according to the curvature of the two pitches in the case of roofing with curved pitches. In any case, each bracket 2 is then fixed to the roofing boards 12 by means of the screws 16.

[0031] As mentioned, the brackets 2 must be fixed at a distance defined in design and in general it is sufficient for them to be fixed at a reciprocal distance of about one meter.

[0032] Appropriately, after having completed the installation of the brackets 2, it is possible to complete the waterproofing of the roofing with appropriate sheets 36 of waterproofing material (sheet, sheathing, etc.), which in addition to concerning the covering boards 12 also concern the brackets 2 and are then bended upwards along the ridge line, for the successive positioning adhering to the lower part of the side wings 24 of the support 4, not concerned by the ventilation openings 26.

[0033] After the roof covering has been made, the perforated support 4 is fixed to the brackets 2; the fixing firstly provides arranging the support 4 on the brackets 2, so that the central wing 20 of its U-shaped portion 18 rests on the central portion 10 of all the brackets 2, and then constraining the contacted portions by means of self-tapping screws 28, which cross them both.

[0034] After the support 4 has been fixed to the brackets 2, it is possible to complete the waterproofing of the roofing with the sheets of waterproofing material 36 (sheet, sheathing, etc.) which in addition to concerning the covering boards 12 also cover the brackets 2 and are taken to also adhere to the lower part of the support 4, and i.e. to the two lower parts of side wing 24 not concerned by the ventilation openings 26.

[0035] Finally, the ridge cap 6 is applied to the perforated support 4, the ridge cap being advantageously coupled by snapping with its longitudinal edge 34 to the bands 27 or 29, protruding or inclined downwards with

respect to the side bands 25 of the perforated support 4.

[0036] The advantages of the ventilated ridge according to the invention with respect to traditional ventilated ridges is apparent from the above, i.e. in particular:

- the possibility of direct, stable and secure constraining of the ventilated ridge to the roofing with the fixing points chosen as a function of the needs of installation and use,
- the possibility of adapting the ventilated ridge to roofing with variably inclined pitches,
- the elimination of all fixing members from sight,
- the constraining simplicity by simple coupling of the ridge cap 6 to the perforated sheet support 4,
- the possibility of having a support between the perforated support 4 and the ridge cap 6 adapted to allow the thermal expansion of the latter,
- the possibility of using the ventilated ridge on multiple roof covering types.

Claims

1. A ventilated ridge for buildings, comprising a perforated sheet support (4) to be fixed to the top of two pitches of the roofing (12) of the building which are either inclined or bent in opposite sense and a ridge cap (6) to be constrained to said support (4), and which comprises:

- a plurality of brackets (2) to be applied at predetermined distances to said roofing (12), each bracket comprising a central portion (10) and two end portions (8), which can be shaped with respect to said central portion (10) according to the pattern of said pitches of the roofing (12),
- constraining means (16) of said brackets (2) to said roofing (12),
- a perforated support (4), which can be constrained to said brackets (2), previously constrained to said roofing (12), and comprising a substantially U-shaped portion (18) and folded side portions (21), said folded side portions (21) comprising:

- first bands (23), which run from the respective upper ends of the side wings (24) of the U-shaped element and which develop downwards,
- second bands (25), which run from the respective ends of the first bands (23) and which develop outwards with respect to said first bands (23),

- constraining means (28) of the central wing (20) of said U-shaped portion (18) of said perforated support (4) to the central portion (10) of each of said brackets (2),

- a ridge cap (6) comprising a central band (30) for resting on the side wings (24) of said U-shaped portion (18) of said perforated support (4) and side bands (32) with the free edge (34) folded to couple on site the corresponding free outer edge of the folded side portions (21) of said support (4),

characterized in that said folded side portions (21) comprise third bands (27), which run from the respective ends of the second bands (25) and which develop downwards with respect to said second bands (25), and **in that** said first bands (23) of said support (4) run externally and parallel with respect to the side wings (24) of said support (4).

2. A ventilated ridge according to claim 1, **characterized in that** each bracket (2) is provided with facilitated folding lines separating said central portion (10) from each end portion (8).

3. A ventilated ridge according to one or more of the preceding claims, **characterized in that** it comprises fixing screws (16) of each bracket (2) to said roofing (12).

4. A ventilated ridge according to one or more of the preceding claims, **characterized in that** said perforated support (4) consists of a single sheet element folded to define said U-shaped portion (18), with the central wing (20) and the two side wings (24), and to defined said first bands (23), said second bands (25) and said third bands (27) in sequence.

5. A ventilated ridge according to one or more of the preceding claims, **characterized in that** each first band (25) of said support (4) comprises a downward folding of the upper end of one of the side wings (24) of the U-shaped portion (18).

6. A ventilated ridge according to one or more of the preceding claims, **characterized in that** each second band (25) is folded laterally outwards by about 90° with respect to the first band (25) and develops substantially horizontally.

7. A ventilated ridge according to one or more of the preceding claims, **characterized in that** said side bands (32) of said ridge cap (6) rest externally on said third bands (27) of said perforated support (4).

8. A ventilated ridge according to one or more of the preceding claims, **characterized in that** said side bands (32) of said ridge cap (6) are inclined downwards by an angle which substantially corresponds to that of the third bands (27) of said perforated support (4).

9. A ventilated ridge according to one or more of the preceding claims, **characterized in that** said third bands (27) end with fourth bands (29) which are folded vertically downwards with respect to said third bands (27). 5
10. A ventilated ridge according to claim 9, **characterized in that** said fourth bands (29) define an edge which can be coupled by the free edge (34) of said ridge cap (6). 10
11. A ventilated ridge according to one or more of the preceding claims, **characterized in that** it comprises self-tapping constraining screws (28) of the central wing (20) of said U-shaped portion (18) of said perforated support (4) to the central portion (10) of each of said brackets (2). 15
12. A ventilated ridge according to one or more of the preceding claims, **characterized in that** it comprises ventilation openings (26) obtained in said side wings (24) of said U-shaped portion (18) and/or in said first bands (23) and/or in said second bands (25). 20
13. A ventilated ridge according to one or more of the preceding claims, **characterized in that** said ridge cap (6) comprises two free edges (34) folded inwards and upwards to couple said free outer edge of the folded side portions (21) of said support (4) from underneath. 25
14. A ventilated ridge according to one or more of the preceding claims, **characterized in that** it further comprises waterproofing material sheets (36) positioned so as to line said roofing (12) and/or the end portions (8) of said brackets (2) so as to adhere externally to the lower parts of the side wings (24) of the support (4). 30

- ein Pressmittel (16) der Halterungen (2) an der Bedachung (12),
 - einen Lochträger (4), der an die Halterungen (2), die zuvor an die Bedachung (12) gepresst wurden, gepresst werden kann und einen im Wesentlichen geformten Abschnitt (18) und abgekantete Seitenabschnitte (21) umfasst, wobei die abgekanteten Seitenabschnitte (21) umfassen:

- erste Leisten (23), die von den jeweiligen oberen Enden der Seitenflügel (24) des U-förmigen Elements verlaufen und die sich nach unten entwickeln,
- zweite Leisten (25), die von den jeweiligen Enden der ersten Leisten (23) verlaufen und die sich nach außen in Bezug auf die ersten Leisten (23) entwickeln,

- ein Pressmittel (28) des Mittelflügels (20) des U-förmigen Abschnitts (18) des Lochträgers (4) an dem Mittelabschnitt (10) von jedem der Halterungen (2),
 - eine Firshaube (6), umfassend eine Mittelleiste (30) zum Aufliegen auf den Seitenflügeln (24) des U-förmigen Abschnitts (18) des Lochträgers (4) und Seitenleisten (32) mit der freien Kante (34) abgekantet, um die entsprechende freie Außenkante der abgekanteten Seitenabschnitte (21) des Trägers (4) vor Ort zu koppeln,

dadurch gekennzeichnet, dass die abgekanteten Seitenabschnitte (21) dritte Leisten (27) umfassen, die von den jeweiligen Enden der zweiten Leisten (25) verlaufen und die sich nach unten in Bezug auf die zweiten Leisten (25) entwickeln, und dadurch, dass die ersten Leisten (23) des Trägers (4) nach außen und parallel in Bezug auf die Seitenflügel (24) des Trägers (4) verlaufen.

Patentansprüche

1. Belüfteter First für Gebäude, umfassend einen Lochblechträger (4), der oben an den zwei Schrägen der Bedachung (12) des Gebäudes, die in entgegengesetzter Richtung entweder geneigt oder gebogen sind, zu befestigen ist, und eine Firshaube (6), die auf den Träger (4) zu pressen ist, und der Folgendes umfasst: 45
- eine Vielzahl von Halterungen (2), die in vorher festgelegten Abständen an der Bedachung (12) anzuordnen sind, wobei jede Halterung einen Mittelabschnitt (10) und zwei Endabschnitte (8) umfasst, die in Bezug auf den Mittelabschnitt (10) gemäß dem Muster der Schrägen der Bedachung (12) geformt sein können, 50
2. Belüfteter First nach Anspruch 1, **dadurch gekennzeichnet, dass** jede Halterung (2) mit erleichterten Abkantlinien, die den Mittelabschnitt (10) von jedem Endabschnitt (8) trennen, versehen ist. 55
3. Belüfteter First nach einem oder mehreren der vorhergehenden Ansprüche, **dadurch gekennzeichnet, dass** er Befestigungsschrauben (16) von jeder Halterung (2) an der Bedachung (12) umfasst.
4. Belüfteter First nach einem oder mehreren der vorhergehenden Ansprüche, **dadurch gekennzeichnet, dass** der Lochträger (4) aus einem einzigen Blechelement besteht, das abgekantet ist, um den U-förmigen Abschnitt (18) mit dem Mittelflügel (20) und den zwei Seitenflügeln (24) zu definieren und um die ersten Leisten (23), die zweiten Leisten (25) und die dritten Leisten (27) der Reihe nach zu definieren.

5. Belüfteter First nach einem oder mehreren der vorhergehenden Ansprüche, **dadurch gekennzeichnet, dass** jede erste Leiste (25) des Trägers (4) eine nach unten gerichtete Abkantung des oberen Endes von einem der Seitenflügel (24) des U-förmigen Abschnitts (18) umfasst.
6. Belüfteter First nach einem oder mehreren der vorhergehenden Ansprüche, **dadurch gekennzeichnet, dass** jede zweite Leiste (25) lateral nach außen um etwa 90° in Bezug auf die erste Leiste (25) abgekantet ist und sich im Wesentlichen horizontal entwickelt.
7. Belüfteter First nach einem oder mehreren der vorhergehenden Ansprüche, **dadurch gekennzeichnet, dass** die Seitenleisten (32) der Firsthaube (6) außen auf den dritten Leisten (27) des Lochträgers (4) aufliegen.
8. Belüfteter First nach einem oder mehreren der vorhergehenden Ansprüche, **dadurch gekennzeichnet, dass** die Seitenleisten (32) der Firsthaube (6) um einen Winkel, der im Wesentlichen demjenigen der dritten Leisten (27) des Lochträgers (4) entspricht, nach unten geneigt sind.
9. Belüfteter First nach einem oder mehreren der vorhergehenden Ansprüche, **dadurch gekennzeichnet, dass** die dritten Leisten (27) mit vierten Leisten (29), die vertikal nach unten in Bezug auf die dritten Leisten (27) abgekantet sind, abschließen.
10. Belüfteter First nach Anspruch 9, **dadurch gekennzeichnet, dass** die vierten Leisten (29) eine Kante definieren, die durch die freie Kante (34) der Firsthaube (6) gekoppelt sein kann.
11. Belüfteter First nach einem oder mehreren der vorhergehenden Ansprüche, **dadurch gekennzeichnet, dass** er selbstschneidende Pressschrauben (28) des Mittelflügels (20) des U-förmigen Abschnitts (18) des Lochträgers (4) an dem Mittelabschnitt (10) von jeder der Halterungen (2) umfasst.
12. Belüfteter First nach einem oder mehreren der vorhergehenden Ansprüche, **dadurch gekennzeichnet, dass** er Belüftungsöffnungen (26), die in den Seitenflügeln (24) des U-förmigen Abschnitts (18) und/oder in den ersten Leisten (23) und/oder in den zweiten Leisten (25) erhalten sind, umfasst.
13. Belüfteter First nach einem oder mehreren der vorhergehenden Ansprüche, **dadurch gekennzeichnet, dass** die Firsthaube (6) zwei freie Kanten (34) umfasst, die nach innen und nach oben abgekantet sind, um die freie Außenkante der abgekanteten Seitenabschnitte (21) des Trägers (4) von unten zu kop-

pein.

14. Belüfteter First nach einem oder mehreren der vorhergehenden Ansprüche, **dadurch gekennzeichnet, dass** er ferner Abdichtungsmaterialbahnen (36) umfasst, die angeordnet sind, um die Bedachung (12) und/oder die Endabschnitte (8) der Halterungen (2) zu verkleiden, um extern an den unteren Teilen der Seitenflügel (24) des Trägers (4) anzuliegen.

Revendications

1. Un façitage ventilé pour bâtiments, comprenant un support en feuille en métal perforée à fixer au sommet de deux pans de la toiture du bâtiment qui sont soit inclinés ou coudés en sens inverse, et une coiffe faîtière à contraindre audit support et qui comprend :

- une pluralité de tasseaux (2) à appliquer à ladite toiture (12) à des distances prédéterminées, chaque tasseaux comprenant une partie centrale (10) et deux parties d'extrémité (8) pouvant être conformées par rapport à ladite partie centrale (10.) selon le motif desdits pans de la toiture (12),

- des moyens de contrainte (16) desdits tasseaux (2) à ladite toiture (12),

- un support perforé (4), qui peut être contraint auxdites tasseaux (2), préalablement contraint à ladite toiture (12), et comprenant une partie sensiblement en forme de U (18) et des parties latérales pliées (21), ledit parties pliées (21) comprenant:

- des premières bandes (23), qui partent des extrémités supérieures respectives des ailes latérales (24) de l'élément en forme de U (18) et qui se développent vers le bas,

- des deuxièmes bandes (25), qui partent des extrémités respectives des premières bandes (23) et se développent vers l'extérieur par rapport auxdites premières bandes (23), et

- des moyens de contrainte (28) de l'aile centrale (20) de ladite partie en forme de U (18) dudit support perforé (4) sur la partie centrale (10) de chacun desdits tasseaux (2),

- une coiffe faîtière (6) comprenant une bande centrale (30) destinée à reposer sur les ailes latérales (24) de ladite partie en forme de U (18) dudit support perforé (4) et des bandes latérales (32) avec le bord libre (34) plié pour coupler sur place le bord extérieur libre correspondant des parties latérales pliées (21) dudit support (4),

caractérisé en ce que lesdites parties latérales

- pliées (21) comprennent des troisièmes bandes (27) qui partent des extrémités respectives des deuxièmes bandes (25) et se développent vers le bas par rapport auxdites deuxièmes bandes (25), et **en ce que** lesdites premières bandes (23) dudit support (4) s'étendent extérieurement et parallèlement aux ailes latérales (24) dudit support (4).
2. Faîtage ventilée selon la revendication 1, **caractérisée en ce que** chaque tasseau (2) est munie de lignes de pliage facilitées séparant ladite partie centrale (10) de chaque partie d'extrémité (8).
3. Faîtage ventilée selon l'une ou plusieurs des revendications précédentes, **caractérisée en ce qu'elle** comprend des vis de fixation (16) de chaque tasseau (2) à ladite toiture (12).
4. Faîtage ventilée selon une ou plusieurs des revendications précédentes, **caractérisée en ce que** ledit support perforé (4) est constitué d'un seul élément en feuille plié pour définir ladite partie en forme de U (18), avec l'aile centrale (20) et les deux ailes latérales (24), et pour définir lesdites premières bandes (23), lesdites secondes bandes (25) et lesdites troisièmes bandes (27) en séquence.
5. Faîtage ventilée selon une ou plusieurs des revendications précédentes, **caractérisée en ce que** chaque première bande (25) dudit support (4) comprend un pliage vers le bas de l'extrémité supérieure de l'une des ailes latérales (24) de la partie en forme de U (18).
6. Faîtage ventilée selon l'une ou plusieurs des revendications précédentes, **caractérisée en ce que** chaque deuxième bande (25) est pliée latéralement vers l'extérieur d'environ 90° par rapport à la première bande (25) et se développe sensiblement horizontalement.
7. Faîtage ventilée selon une ou plusieurs des revendications précédentes, **caractérisée en ce que** lesdites bandes latérales (32) de ladite coiffe faîtière (6) reposent extérieurement sur lesdites troisièmes bandes (27) dudit support perforé (4).
8. Faîtage ventilée selon une ou plusieurs des revendications précédentes, **caractérisée en ce que** lesdites bandes latérales (32) de ladite coiffe faîtière (6) sont inclinées vers le bas d'un angle qui correspond sensiblement à celui des troisièmes bandes (27) dudit support perforé (4).
9. Faîtage ventilée selon l'une ou plusieurs des revendications précédentes, **caractérisée en ce que** lesdites troisièmes bandes (27) se terminent par des quatrièmes bandes (29) qui sont pliées verticalement vers le bas par rapport auxdites troisièmes bandes (27).
10. Faîtage ventilée selon une ou plusieurs des revendications précédentes, **caractérisée en ce que** lesdites quatrièmes bandes (29) définissent un bord qui peut être couplé par le bord libre (34) de ladite coiffe faîtière (6).
11. Faîtage ventilée selon une ou plusieurs des revendications précédentes, **caractérisée en ce qu'elle** comprend des vis auto-taraudeuses de contrainte (28) de l'aile centrale (20) de ladite partie en forme de U (18) dudit support perforé (4) à la partie centrale (10) de chacun desdits tasseaux (2).
12. Faîtage ventilée selon une ou plusieurs des revendications précédentes, **caractérisée en ce qu'elle** comprend des ouvertures de ventilation (26) obtenues dans lesdites ailes latérales (24) de ladite partie en forme de U (18) et / ou dans lesdites premières bandes (23) et / ou dans lesdites deuxièmes bandes (25).
13. Faîtage ventilée selon une ou plusieurs des revendications précédentes, **caractérisée en ce que** ladite coiffe faîtière (6) comprend deux bords libres (34) repliés vers l'intérieur et vers le haut pour coupler ledit bord extérieur libre des parties latérales pliées (21) dudit support (4) de dessous.
14. Faîtage ventilée selon une ou plusieurs des revendications précédentes, **caractérisée en ce qu'elle** comprend en outre des feuilles de matériau d'étanchéité (36) positionnées de manière à recouvrir ladite toiture (12) et / ou les parties d'extrémité (8) desdits tasseaux (2) de manière à adhérer extérieurement aux parties inférieures des ailes latérales (24) du support (4).

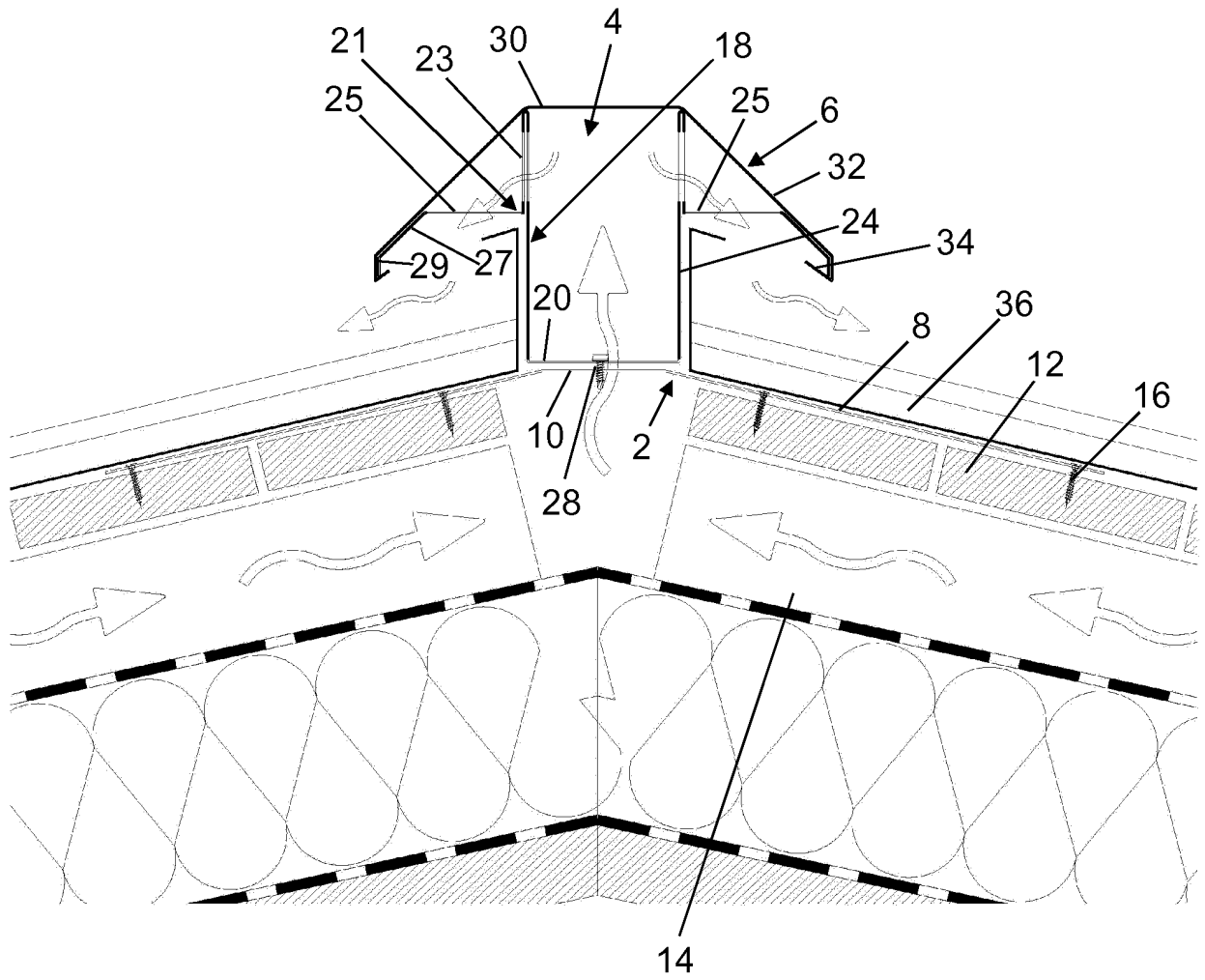
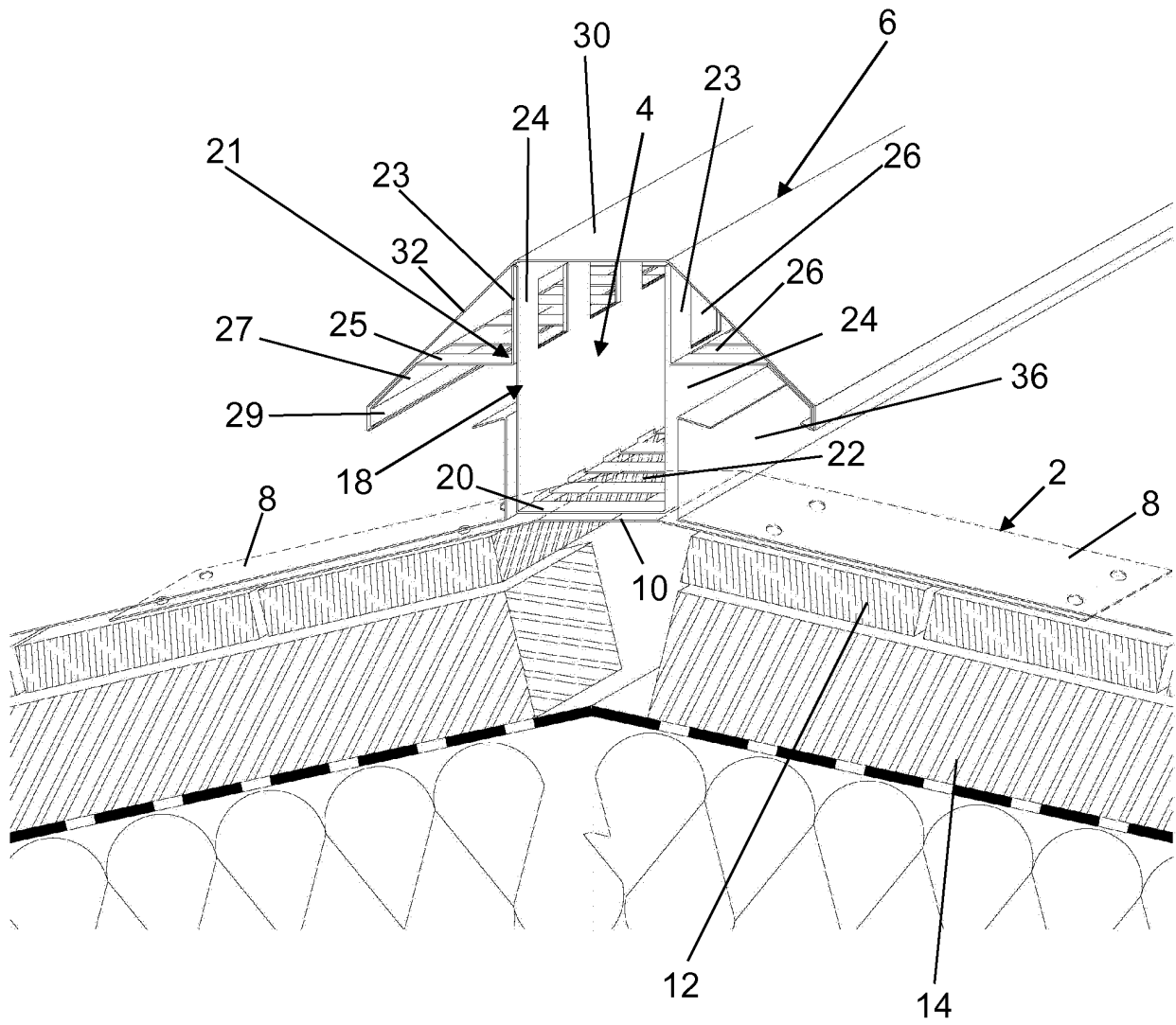

FIG. 1



REFERENCES CITED IN THE DESCRIPTION

This list of references cited by the applicant is for the reader's convenience only. It does not form part of the European patent document. Even though great care has been taken in compiling the references, errors or omissions cannot be excluded and the EPO disclaims all liability in this regard.

Patent documents cited in the description

- FR 2399515 [0004]