

(19)



(11)

EP 3 258 812 B2

(12)

NEW EUROPEAN PATENT SPECIFICATION

After opposition procedure

(45) Date of publication and mention of the opposition decision:
22.11.2023 Bulletin 2023/47

(51) International Patent Classification (IPC):
A45D 1/06 ^(2006.01) **A45D 1/28** ^(2006.01)
A45D 2/00 ^(2006.01)

(45) Mention of the grant of the patent:
09.01.2019 Bulletin 2019/02

(52) Cooperative Patent Classification (CPC):
A45D 1/06; A45D 1/28; A45D 2/001

(21) Application number: **16709493.7**

(86) International application number:
PCT/GB2016/050382

(22) Date of filing: **16.02.2016**

(87) International publication number:
WO 2016/132116 (25.08.2016 Gazette 2016/34)

(54) **HAIR STYLING APPLIANCE**

HAARFORMGERÄT

APPAREIL DE COIFFURE

(84) Designated Contracting States:
AL AT BE BG CH CY CZ DE DK EE ES FI FR GB GR HR HU IE IS IT LI LT LU LV MC MK MT NL NO PL PT RO RS SE SI SK SM TR

- **GAGIANO, Mark Andrew**
Piara Waters, Western Australia 6112 (AU)
- **MOORE, Timothy David**
Royston
Hertfordshire SG8 7XP (GB)

(30) Priority: **19.02.2015 GB 201502763**

(74) Representative: **MacDougall, Alan John Shaw et al**
Mathys & Squire
The Shard
32 London Bridge Street
London SE1 9SG (GB)

(43) Date of publication of application:
27.12.2017 Bulletin 2017/52

(73) Proprietor: **Jemella Limited**
Leeds
Yorkshire LS11 5BZ (GB)

(56) References cited:
WO-A1-2004/019726 **WO-A1-2012/028862**
GB-A- 2 477 834 **GB-A- 2 500 733**
GB-A- 2 508 590 **US-A1- 2012 111 354**

(72) Inventors:

- **WEATHERLY, Robert Alexander**
Cambridge
Cambridgeshire CB10 1QY (GB)

EP 3 258 812 B2

Description

FIELD OF THE INVENTION

5 **[0001]** This invention relates to hair styling appliances, in particular low voltage, for example battery operated devices.

BACKGROUND TO THE INVENTION

10 **[0002]** There are a variety of apparatus available for styling hair. One form of apparatus is known as a straightener which employs plates that are heatable. To style, hair is clamped between the plates and heated above a transition temperature where it becomes mouldable. Depending on the type, thickness, condition and quantity of hair, the transition temperature may be in the range of 160-200°C.

[0003] A hair styling appliance can be employed to straighten, curl and/or crimp hair.

15 **[0004]** The temperature range required, user expectations with regard to the time to heat-up, thermal control, and other factors combine to drive existing hair styling appliances to employ mains power for the heater(s).

[0005] In GB2477834, WO2014/001769 and GB2503521 to the present applicant, a hair styling appliance including a battery power source for at least one heater is taught.

[0006] The inventors have realised that further improvement in the use of a battery power source is possible.

20 SUMMARY OF THE INVENTION

[0007] The present invention is defined in the appended claims and any examples and embodiments not falling within the scope of the claims do not form part of the invention and are provided for illustrative purposes only. A hair styling apparatus is described comprising: a plurality of heater electrodes which heat one or more hair styling heaters, the plurality of heaters comprising a first subset and a second subset; a power source for powering the plurality of heater electrodes and a controller configured to control powering of the plurality of heater electrodes from the power source, wherein, in a first mode of operation, the controller is configured to control the power source so that the first and second subsets of the plurality of heaters are not simultaneously powered. The power source may be a battery source. Alternatively, the power source may be mains power.

30 **[0008]** In this first mode of operation, the controller controls power delivery so that power is delivered to the first and second subsets in a time interleaved manner, multiple times per second. Interleaving the power delivery in this way offers a number of advantages. For example, if the first subset of heater electrodes is associated with a first hair styling heater and the second subset of heater electrodes is associated with a second hair styling heater, then the controller can control the heating of the first and second hair styling heaters so that they are both heated, at the same time, to respective desired operating temperatures (which may be the same). Similarly, if the first and second subsets of heater electrodes are associated with different parts of one hair styling heater then the controller can control the heating of the different parts of the heater so that they are both heated, at the same time, to a desired operating temperature. This is possible as such hair styling heaters (and other kinds of heaters) normally have a relatively high thermal inertia so that they do not cool down quickly once power is removed from the heater electrodes.

40 Interleaving of the driving of the electrodes in this manner also reduces the current drawn from the power source. When the power source is a battery, reducing the current draw is important as this reduces the energy lost in the internal resistance of the battery: $P=I^2R$, where I is the current drawn and R is the internal resistance. Hence operating in this first mode of operation provides the most efficient heating of the heaters. Of course, in other modes of operation heaters from the first and second subsets may be powered simultaneously, for example, if the load is very high.

45 The controller may be configured to select the first and second subsets so that a total current drawn by each of the first and second subsets is below a predetermined current threshold. This is particularly useful for a battery power source because keeping the current draw below the threshold may prevent the battery from overheating (due to the above described I^2R losses). The predetermined current threshold may be equivalent to a multiple (e.g. 1.5) of the current draw for a single heater electrode.

50 In other words, the controller is configured to control powering of the heater electrodes from the power source. The first mode of operation of the controller (there may only be the one mode) comprises limiting the total number of heater electrodes that may be simultaneously powered such that a predetermined current limit is not exceeded. The fact a current limit is imposed means that the controller is configured to prevent all the heater electrodes being powered at the same time. This current limit may be deemed a nominal current draw.

55 **[0009]** The plurality of heater electrodes may be divided into discrete subsets. Thus no heater electrodes are in both the first and second subsets. Alternatively, the first and second subsets may have some (but not all) heater electrodes in common. It will be appreciated that there may be more than two subsets of electrodes, e.g. three or even four, depending on the overall number of heater electrodes within the apparatus. Each subset may comprise one or more

electrodes.

[0010] The controller may be configured to switch the power source between the first and second subsets, for example multiple times per second. This may be done, for example, to maintain the heater at a desired operating temperature. The controller may comprise a heating cycle in which it cycles through all of the subsets of powerable heater electrodes, determining if power may need to be applied. If not, the controller may opt to retain power to the currently powered subset, switch to another, or opt to power none of the heater electrodes if heater plates (or zones on a heater plate) are at a preferred operating temperature. The switching frequency between each subset may be in the order of tens, hundreds or thousands of cycles per second. Typically the heating cycle will have a period of between 100 μ s and 500ms. The first and second subsets may be powered in anti-phase, i.e. one subset is off when the other subset is on. In such anti-phase operation there may however be periods in which none of the electrodes are powered.

[0011] The controller may be configured to alternate between the first mode of operation and a second mode of operation in which the first and second subsets of the plurality of heater electrodes are simultaneously powered. For example, simultaneous heating may take place during the initial heat up from power on. In this second mode of operation, the nominal current draw is exceeded temporarily. When operating in this second mode, the controller may switch the power to both subsets of heater electrodes such that there are: 1) overlapping periods in which power is simultaneously supplied to heater electrodes in the first and second subsets; 2) periods in which power is supplied to heater electrodes of just one of the first and second subsets; and 3) periods in which no power is supplied to heater electrodes of the first and second subsets. The controller may control the duration of the overlapping periods so that they reduce with time from, for example, an initial switching on time. The controller may reduce the duration of the overlap either in response to a sensed condition or based on pre-stored data defining the switching sequence.

[0012] The controller may be configured to switch from the second mode of operation to the first mode of operation in response to a control signal. The control signal may be that a predetermined amount of time in the second mode of operation has elapsed. The predetermined amount of time may be based on predetermined characteristics of the battery power source and may be a few seconds. The controller may then continue to operate in the first mode of operation for a further period of time (for example 30 seconds or more) after which periods of operating in the second mode may be possible.

[0013] Where the power source is a battery source, the hair styling apparatus may further comprise a battery temperature sensor which senses the temperature of the battery source and which sends a battery temperature sense signal to the controller. In some embodiments a battery temperature sensor may be integrated into the hair styling apparatus, however in other embodiments the battery power source may comprise an integrated temperature sensor having a connection coupleable to the battery temperature sense input.

[0014] The battery temperature sense signal may be compared to a battery temperature threshold and the control signal may be generated by the controller or at the sensor when the battery temperature sense signal is greater than the battery temperature threshold. Alternatively, the control signal may be generated when the battery temperature is increasing at a rate such that a threshold value is predicted to be exceeded. The battery temperature threshold may be in the range of 60 to 80 degrees C, more preferably 70 degrees C.

[0015] There may also be temperature sensor sensing ambient temperature. Said control signal may be generated by the controller or the sensor when the sensed ambient temperature is below a threshold ambient temperature. The ambient temperature threshold may be in the range of 25-35 degrees C, more preferably 25 or 33 degrees C.

[0016] In other words, the controller may be configured to limit a duration in which the subsets of heater electrodes are simultaneously powerable by the power source. This may also be dependent on the battery temperature or ambient temperature.

[0017] The hair styling apparatus may comprise a first arm having a first contacting surface and a second arm having a second contacting surface, wherein the arms are moveable between a closed position in which the first and second contacting surfaces are adjacent and an open position in which the first and second contacting surfaces are spaced apart. The first arm may comprise a first hair styling heater having a plurality of heater electrodes. The first arm comprises a first hair styling heater and the second arm comprises a second hair styling heater and each hair styling heater comprises at least one heater electrode. In this arrangement, the plurality of electrodes comprises at least one on each arm. A plurality of electrodes includes two electrodes. Where there are only two electrodes, e.g. one on each arm or a single heater with two electrodes, the first subset may comprise the first electrode and the second subset may comprise the second electrode.

[0018] The hair styling apparatus may further comprise a touch sensitive switch configured to enable or disable the hair styling apparatus. It will be appreciated that the touch sensitive switch can be used on its own as a separate invention as well as in conjunction with the different powering modes of operation.

[0019] For an apparatus having a pair of arms as described above, the touch sensitive switch may be located on the first or second contacting surface. When the arms are in the closed position, the touch sensitive switch may be deactivated to prevent unintended activation of the switch. In use, a user may activate the touch sensitive switch by pressing on or otherwise contacting said touch sensitive switch for at least a predetermined duration of time. This activation may be

determined by the switch or the controller and the controller may enable or disable the hair styling apparatus responsive to said determining.

[0020] The or each heater may comprise a heater plate which is mounted on a thermally insulating support structure. It will be appreciated that the thermally insulating support structure can be used on its own as a separate invention as well as in conjunction with the different powering modes of operation and/or touch sensitive switch.

[0021] The heater plate may comprise at least one recess which cooperates with a corresponding projection on the thermally insulating support structure. The recess and projection may be L-shaped. Other mechanisms for mounting the heater plate on the support may be used. The thermally insulating support structure may be resiliently mounted within an arm of the hair styling apparatus. For example, a spring mechanism may be used. Such a resilient mounting allows the heater plate to move relative to the casing of the arm during styling, allowing the plates to retain contact with varying thicknesses and changes in the profile of hair clamped between opposing pairs of styling surfaces on the heater plates.

[0022] Also described is a method of controlling a hair styling apparatus comprising a plurality of heater electrodes which heat one or more hair styling heaters, the plurality of heaters comprising a first subset and a second subset; the method comprising: controlling powering of the heater electrodes so that the first and second subsets of the plurality of heaters are not simultaneously powered.

[0023] Also described is a controller for a hair styling appliance, wherein the controller configured is configured to implement the method described above.

BRIEF DESCRIPTION OF THE DRAWINGS

[0024] These and other aspects of the invention will now be further described, by way of example only, with reference to the accompanying figures in which:

Figure 1 shows a first example of a hair styling appliance in which embodiments of the invention may be employed;

Figure 2 shows a schematic block diagram of a hair styling appliance of the type illustrated in Figure 1;

Figure 3 shows a plan view of an embodiment of a hair styling heater for use in the hair styling appliance of Figure 1;

Figures 4a and 4b show timing diagrams illustrating example duty cycles of heating electrodes driven, for example, by the control system in Figure 2;

Figure 5 shows a variant of the schematic block diagram of Figure 2;

Figures 6a to 6d show timing diagrams illustrating example duty cycles of heating electrodes driven, for example, by the control system in Figure 5; and

Figure 7 shows a cross sectional view of the hair styling appliance.

DETAILED DESCRIPTION OF THE PREFERRED EMBODIMENTS

[0025] Figure 1 depicts an example of a typical hair straightener 1. The hair straightener 1 includes first and second arms each comprising an arm member 4a, 4b and heatable plates 6a, 6b coupled to heaters (not shown) in thermal contact with the heatable plates. The heatable plates are substantially flat and are arranged on the inside surfaces of the arms in an opposing formation. During the straightening process, hair is clamped between the hot heatable plates and then pulled under tension through the plates so as to mould it into a straightened form. The hair straightener may also be used to curl hair by rotating the hair straightener 180° towards the head prior to pulling the hair through the hot heatable plates.

[0026] Also shown in Figure 1 is touch sensitive switch 5070 which is used to power the hair styling appliance on and off. The switch may be implemented as a capacitive touch switch comprising an electrode placed behind the plastic casing of the hair styling appliance. This obviates the need for a mechanical switch in variants a resistive touch sensitive switch may also be used, or a piezo touch switch. As shown in Figure 1, the touch sensitive switch 5070 is positioned on the inside of an arm facing the other arm. This means that the switch can only be pressed when the arms are spaced apart to prevent a user accidentally touching the switch and unintentionally turning the hair styling appliance on. Further, should the hair styling appliance be placed in luggage, such as a handbag, if a user rummages around in the bag for an item, it also prevents any accidental pressing of the switch. As a further safety mechanism, in embodiments the switch may also be deactivated (or the power supply configured to prevent activation of the appliance) when the arms of the hair styling appliance are closed together.

[0027] It will be appreciated that a hair straightener is just one example of a hair styling appliance and a skilled person would implement the various embodiments of the invention without difficulty into other hair styling appliances such as a "crimping iron" for crimping hair or a hair styling appliance for curling hair.

5 [0028] Figure 2 shows a block diagram of a power/control system 500 for a hair styling appliance incorporating a heater 300. The system comprises a low voltage power supply 504 deriving power from a 12v lithium ion battery 505 and/or a mains power supply input 502, which is used to charge the battery 505 via an AC to DC converter 503 which may be external or internal to the appliance. Power supply 504 may be configured to provide approximately 100 watts per heater; the heater resistance when hot may be selected accordingly - for example at 12v a current in the range 5-10
10 amps may be delivered to a heater with a resistance in the range 1-2 ohms. The resistance may be scaled accordingly as the design voltage increases or decreases (changing as the inverse square of the voltage).

[0029] Power from power supply 504 is provided to a power control module 514, which in turn powers the one or more heaters 516. Power control module 514 may employ one or more power semiconductor switching devices to provide pulse width modulation control of the (DC) voltage from power supply 504 to heaters 516. Thus a high percentage on-time duty cycle may be employed during the initial, heating phase and afterwards the on-time duty cycle may be reduced and controlled to control the temperature(s) of the heaters 516.
15

[0030] Power from power supply 504 is also provided to a microcontroller/control means 506 coupled to non-volatile memory 508 storing processor control code for a temperature control algorithm, and to RAM 510. The skilled person will appreciate that any of a wide range of different control algorithms may be employed including, but not limited to, on-off control and proportional control. Optionally the control loop may include a feed-forward element responsive to a further input parameter relating to the hair styling appliance, for example to use the operation of the apparatus to improve the temperature control. An optional user interface 512 is also coupled to microcontroller 506, for example to provide one or more user controls and/or output indications such as a light or audible alert. The output(s) may be employed to indicate, for example, when the temperature of the heating plate has reached an operating temperature, for example in a region 140°C - 185°C.
20

[0031] Microcontroller 506 is also coupled to one or more optional temperature sensors such as thermistors 340. However, as previously mentioned, the temperature of a heating element may be sensed from its resistance and thus embodiments of the system include a current sense input 515 to microcontroller 506 sensing the current provided to a heater, for example via a current-sense resistor connected in series with the electrode. A predetermined calibration of resistance against temperature for an electrode may be stored in non-volatile memory 504 and in this way the printed track may be employed as a temperature sensor.
25

[0032] In the illustrative embodiment of Figure 2, the touch sensitive switch 5070 is shown coupled to the low voltage PSU 504 to remove the need for the microcontroller to be permanently powered up. When off, the low voltage PSU 504 monitors for a change in capacitance of the touch sensitive switch indicating that a user has pressed the switch. The low voltage PSU then powers up the hair styling appliance. When on, the low voltage PSU 504 again monitors for a change in capacitance of the switch, then powering down the hair styling appliance. To power up and down, it may be necessary for a user to press on the touch sensitive switch for a minimum period of time before the PSU fully registers the press as a valid request to power on/off. This eliminates any accidental power up, or when styling, any accidental touching of the touch sensitive switch. A user may, for example, be required to press the touch sensitive switch for two, three, four or five seconds, or longer. In variants two touch sensitive switches may be used: one for turning the styling appliance on, another for turning the styling appliance off.
30

[0033] Providing such a touch sensitive switch on a hair styling appliance provides several advantages. Firstly, for battery powered products, if the hair styling appliance is carried around in luggage, it prevents the appliance being accidentally knocked on by other items in the luggage. Further, it also improves the aesthetic appearance of the product, eliminating the need for additional components on the surface of the hair styling appliance.
35

[0034] In this embodiment the touch sensitive switch is shown coupled to the low voltage PSU. In variants such a switch may be coupled to the microcontroller, although in such variants it will then be appreciated that the microcontroller may then need to be permanently powered to permit detection of a press of the touch sensitive switch. In other variants a dedicated circuit may also be used.
40

[0035] This touch sensitive power switch may be applied to any of the embodiments described herein and also as an adaption to otherwise standard devices.
45

[0036] Each heater plate may be powered by a heater electrode. Depending upon the thickness of the heater plate, lateral conductivity within the plate may not be sufficient to give the desired results with a single heater electrode. Accordingly, an example of a heater plate is illustrated in Figure 3 which may form the heatable plates 6a, 6b of the hair straightener of Figure 1. The heater plate 300 may be provided with a plurality of separately controllable heating zones 300a, b, each with a respective electrode 330a, b and thermistor 340a, b. Connections to these are brought out, for convenience, to one edge of the heater plate; a broadened track region 332 is provided for the electrode further from the connection point to reduce heating in the connection path. Each of the electrodes is provided with a separate control loop controlled by the temperature sensed by the respective thermistor. In embodiments more than 3 zones may be
50

provided.

[0037] The heater used in the various embodiments described herein may be formed as described in WO2014/001769 and GB2503521 which are incorporated by reference. Thus, the heater may comprise an aluminium heater plate of thickness of order 1mm, bearing a plasma electrolytic oxide (PEO) coating of aluminium oxide of thickness less than 100 μ m, for example in the range 5-15 μ m.

[0038] The hair styling appliance comprises a plurality of electrodes. As shown in Figure 1, there may be two heater plates, each with their own electrode and thus there are two electrodes. Alternatively, only one arm of the appliance shown in Figure 1 may comprise a heater plate but this heater plate comprises at least two, possibly more electrodes. There may also be multiple heater plates each having multiple electrodes.

[0039] The power to the plurality of heater electrodes may be independently controlled. For example, for an appliance having two arms, each with a heater and one heater electrode for each heater, Figures 4a and 4b show the Voltage against Time for each heater electrode. In this example illustration, the microcontroller 506 uses pulse width modulation (PWM) power control to control the supply of power to the two heater electrodes using the power control block 514. In pulse width modulation power control, the "on time" of the power signal within a sequence of PWM periods (here labelled 'd' and also referred to in other parts of this document as heater cycles) is varied in order to vary the amount of power delivered to each heater electrode. Typically, the PWM period / heater cycle may be between 100 μ s and 500ms. It will be observed from Figures 4a and 4b that initially both heater electrodes are powered simultaneously until the desired operating temperature is reached. A high percentage on-time duty cycle within any given period 'd' may be employed during the initial heating phase; afterwards the on-time duty cycle may be reduced for each heater so as to retain the hair styling heater at a desired operating temperature. Each heater may be controlled independently to stabilise the temperature of each heater at the desired operating temperature. Accordingly, the draw is not exactly the same for both heater electrodes. Nevertheless, it can be observed from Figures 4a and 4b that there may be sustained periods of a maximum current draw as a result of both heaters being powered simultaneously.

[0040] When powered by battery, a high current draw, such as from driving both heaters simultaneously, may lead to the battery power source heating up to an unacceptably high temperature. This may be exacerbated if both heaters are simultaneously driven for extended periods of time. The current draw when simultaneously driving the heaters, combined with a desire to conceal the battery power source means that heat dissipation may become an important factor in the construction of such a hair styling appliance.

[0041] Figure 5 shows a variant of the schematic block diagram of Figure 2 with modified microcontroller/control means and power control module 514b. The reference numbers in common are used in both systems and thus any description applies equally to both.

[0042] The microcontroller switching control signal 708, labelled 'temp/power control' in Figure 5 may comprise multiple outputs, one for each heater power switch to be controlled. The embodiment shown in Figure 5 comprises two heater electrodes, one on each of the two heater plates. Two outputs, one to activate the first heater electrode via the first power switch 702 and the second to activate the second heater electrode via the second power switch 704 are present on the power control module. In Figure 5, further heater electrodes may also be driven. These may be present, for example, in a multizoned heater variant. Dotted arrow lines to the heaters 516 show optional connections to such additional heater elements.

[0043] In variants the switching control signal may be a serial data connection or encoded such that the control system can scale to independently control multiple heater elements. This may be particularly useful in embodiments having multiple heating zones (two or three per heater for example) and where the number of outputs from the microcontroller may be limited. Alternatively the microcontroller may have multiple outputs, one for each power switch. The optional decode block 706 in the power control module 514b decodes the signal received from the microcontroller and splits this out into separate drive signals to activate the power switches 702 and 704. In variants incorporating multiple heating zones on each heater plate the signal may be decoded into more outputs, one for each zone.

[0044] Battery power source 505 in Figure 5 may further incorporate a battery temperature sensor 5050, such as a thermistor. The battery temperature sensor 5050 provides a battery temperature sense signal 5051 coupled to the microcontroller 506. The battery temperature sense signal may be factored into the temperature control algorithm and powering of the heater plates. It will be appreciated however that such a feature is optional.

[0045] In the embodiment shown in Figure 5, the battery temperature sensor may also be used as part of the safety shutdown 520. As set out above, the styling appliance may incorporate one or more safety shut down circuits 520 coupled to the one or more heater electrodes and/or temperature sensors 340 to monitor the heater temperature and electronically shut down the power supply to the heater should overheating be detected. In embodiments, this may be extended to also prevent overheating of the battery. In embodiments safety shut down circuit 520 controls a guard transistor 522, as illustrated a power MOSFET, which removes power from the power control block on detection of a potential fault. Guard transistor 522 may be provided either before or after power control block 514a. In normal operation this device is always on; the device may be selected such that when power is removed from the transistor it switches off, thus failing safe, for example by employing an enhancement - mode device. Such control and safety shut down is applicable to all

the embodiments described herein. The battery temperature sensor 5050 (or another battery temperature sensor) may additionally or alternatively be used to control power on/off of the hair styling appliance. The generated signal $B_{T\text{sense}}$ 5051 is fed into the microcontroller 506 and may be used to provide battery temperature information for use in a safety mechanism to shut down the styling appliance, or stop power delivery to one or more heater elements/plates if the battery temperature exceeds a battery threshold temperature. Thus, the microcontroller/control means may be arranged such that power is only supplied to the heating elements/plates when the temperature sensed by the battery temperature sensor is below a battery threshold temperature. In embodiments, this threshold temperature may be a value in the range of 60-100°C, for example 70°C. However it will be appreciated that the operational threshold temperature may be dependent on the particular construction (packaging, chemical formulation for example) of the particular battery used. Techniques such as active cooling of the battery pack, or heat transfer means such as a heat sink, may often be insufficient to retain the battery pack within its preferred safe operating range.

[0046] Following deactivation of the heater plates, the control system may prevent the hair styling appliance from being used again until the battery temperature has fallen below either the battery threshold temperature at which power down was previously initiated, or below a lower 'reactivation' temperature which would be set to a temperature below the battery threshold temperature.

[0047] Another technique that may be used to prevent heat build-up in the battery power source is to slow the rate of heating by throttling the maximum current delivered or using higher resistance heating elements. However, adopting such a technique may mean that the temperature of a heater plate cannot be changed very rapidly, which may lead to a poor transient response.

[0048] Further, an ambient temperature sensor, such as temperature sensor 5060 in Figure 5 may be used to monitor the ambient temperature (i.e. the temperature surrounding the hair styling appliance) and prevent power delivery to the heater plates if an ambient temperature threshold is exceeded. An ambient temperature sense signal $A_{T\text{sense}}$ 5061 is then generated and fed into the microcontroller 5061. In embodiments, this ambient threshold temperature may be a value in the range of 25-35 degrees C, for example 25 degrees C or 33 degrees C. Such ambient temperature sensing may be used as a further safety mechanism to protect against overheating of the hair styling appliance. This is particularly useful in warmer environments in which the battery which may heat up too fast (such as outside in hot climates, or in a hot indoor environment). A user may then be prevented from turning on the hair styling appliance until the ambient temperature has reduced. Thus, the microcontroller/control means may be arranged such that power is only supplied to the heating elements/plates when the sensed ambient temperature is below an ambient threshold temperature.

[0049] In one or both instances above, if either the ambient or battery threshold temperatures are exceeded; visual or audio feedback may be provided to the user to indicate that the device has entered a safety mode or indicate the temperature status.

[0050] In a first control mode the microcontroller/control means in Figure 5 is configured to lower the maximum current draw by operating the heaters in anti-phase. This means that in an embodiment having two heater electrodes (one for each heater), only one heater element may be powered at a time in the embodiment in Figure 5. Operating in anti-phase, there may also be periods where both heaters electrodes are off, such as when both heater plates are at a desired operating temperature. Given a current draw of '1' for one heater arranged to heat an entire heater plate, when two heaters are powered simultaneously to heat two heater plates, the current draw may be approximately '21'. Using this convention, the maximum current draw is limited to the current draw for driving one heater (i.e. '1', the current draw for one heater arranged to heat an entire heater plate). This means that the controller may be configured to prevent all (both in the embodiment of Figure 5) heater electrodes being powered at the same time.

[0051] Figures 6a and 6b show a graph for each heater in an appliance having two heaters and operating according to the preceding paragraph. As before, the microcontroller 506 uses pulse width modulation power control to control power delivery to the two heaters. It will be observed from Figure 6a and 6b that both heater electrodes are now not powered at the same time within each heating cycle (here labelled 'c'). The dotted lines between the Figures show instances of one heater starting or stopping - note there is no overlap. In a heating cycle ('c'), each of the heaters below temperature are powered in a sequence which may be fixed or determined by the microcontroller, but only one at a time. As before, the heating cycle may be between 100µs and 500ms and thus the controller rapidly switches the delivery of the power between the two heaters such that, as far as the user is concerned, both heaters appear to be heating up simultaneously.

[0052] As will be apparent to those of ordinary skill in the art from Figure 5, the controller 506 controls this delivery of power to the first and second heaters by generating control signals 708 that cause the decode/drive enable unit 706 to open and close the switches 702 and 704. In some cases, the control signals 708 may be directly used to control the switching of the switches 702 and 704.

[0053] The microcontroller may implement a control algorithm configured to allocate equal percentages of a heating cycle 'c' to each heater, for example 50% of the time. Typically this may be the case when a user powers on the appliance to heat both heater plates to the desired operating temperature evenly and as fast as possible. However, in the event that one heater plate heats up slower than the other, a higher portion of time in any given period / heating cycle 'c' may

be allocated to the cooler heater plate. Furthermore, in the event one heater plate cools faster than the other when placed about a quantity of hair, the microcontroller, in response to a temperature dependent sense signal, may act accordingly to allocate a higher portion of heating time in any one heating cycle to power the heater in the cooler heating plate.

5 **[0054]** In some embodiments of the hair styling appliance, there may be multiple heating zones on each heater plate, as shown in Figure 3 for example and also shown in GB2477834, herein incorporated by reference. Each heating zone may comprise a separate heater electrode arranged to heat a portion of the heater plate. In such embodiments, it may then be permissible to simultaneously heat multiple heating zones in many different configurations. The controller may therefore be configured to prevent all the heater electrodes distributed across one or more plates being powered at the
10 the same time (or for only short periods of time).

[0055] As previously discussed, we generally consider a current draw 'I' to correspond to the current draw necessary to power a heater electrode heating an entire heater plate. Thus, in embodiments having multiple heating zones on a heater plate, one electrode in each zone may be considered to draw (for the purposes of comparison only), a portion of current draw 'I'. In an embodiment having two heating zones on each heater plate, i.e. four heating zones in total, each
15 zone may be considered to draw a current of 0.5I (presuming the resistances are generally the same). A maximum preferred current draw 'I' may therefore correspond to powering two zones simultaneously. Any two zones: both on the same plate, or one on each plate may be simultaneously powered. This means that in the event a quantity of hair is placed on only one section of the heater plates, such that only one zone needs to be powered to retain the desired operating temperature, then opposing zones on two heater plates may be simultaneously powered whilst staying within
20 the preferred current draw limit ('I') to prevent the battery source overheating.

[0056] It will be appreciated that the maximum preferred current draw to prevent the battery source overheating may not be 'I', it may instead be higher or lower than this. Therefore, in some embodiments it may then be possible to power different combinations and numbers of heating zones simultaneously without the battery source overheating. By way of
25 example, in an embodiment having two heater zones on each of two heater plates, given a preferred maximum current draw of '1.5I', it may then be possible to power three heater zones simultaneously whilst staying within the preferred current draw limit.

[0057] Table 1 below shows exemplary combinations of the maximum zones that may be powered at any one time. The 'nominal current draw' column provides examples of the nominal current draw limit, defined in multiples of the current
30 draw of one heater arranged to heat an entire heater plate. Accordingly, for the purposes of this illustrative example, the current draw of two heater electrodes, each heating half of a heater plate, is deemed the same as one heater element powering an entire heater plate. It will however be appreciated that in practice the current draw may be different.

Zones per plate	Number of plates in appliance	Nominal draw 'I'	Zones powered at any one time
1	2	1	1
2	2	1	2
3	2	1	3
1	2	1.5	1
2	2	1.5	3
3	2	1.5	3

35 **[0058]** Returning now to the embodiments shown in Figure 5 having one heater electrode in each of two plates, in a second control mode the microcontroller may allow periods of overlap in which both heaters are powered simultaneously to heat up both heater plates at the same time. Given the nominal preferred current draw of 'I', limited periods of a higher current draw may be permitted, so long as these higher current draw periods are interleaved with rest periods in which the nominal preferred current draw is not exceeded. So as to prevent overheating, the duration of overlap may be limited
40 by the microcontroller/control means. The microcontroller/control means may be configured to limit this overlap to a predetermined duration within a fixed period of time based on predetermined characteristics of the battery. The microcontroller may permit, for example, simultaneous heating to only take place during the initial heat up from power on, then revert to the first mode of operation. In other words, the controller may be configured to limit a duration in which the two heater electrodes are simultaneously powerable by the power source. This may also be dependent on the battery
45 temperature or ambient temperature.

[0059] In an enhancement to the second control mode the overlap control may be variable, being controlled, for example, in response to feedback from a battery temperature sense signal 5051 as depicted in Figure 5. In this variant, the microcontroller may then actively monitor the temperature of the battery source, controlling the permissible overlap
50

in which the nominal preferred current draw may be exceeded in response to the temperature of the battery source. This may be useful to allow both heaters (based on an embodiment have one heater element in each heater plate) to be driven simultaneously from cold at power on, with the microcontroller then disabling any overlap in heating once the heaters are first up to temperature.

5 **[0060]** By way of example, Figures 6c and 6d show a graph for each heater in an appliance having two heaters where overlap is permitted. In the first phase, the battery temperature is within the preferred operating range and so the microcontroller is configured to operate in the second control mode with periods in which both heaters are heated simultaneously. In the second phase, the battery temperature sensor may sense the temperature approaching (or exceeding) a threshold temperature which results in the microcontroller changing to the first control of operation in which the heaters are powered in anti-phase. The microcontroller may then optionally return to the second control mode when the temperature of the battery source drops. The dotted lines between the Figures show regions of overlap in heaters being powered in the first phase.

10 **[0061]** The second technique may also be implemented for embodiments having multiple heating zones on one or more of the heater plates. Incorporating the second technique, the microcontroller may then permit various combinations of zones to be heated simultaneously as previously described, with periods in which the nominal preferred current draw is exceeded by powering further heating zones for a limited period of time. This means that the controller may be configured to limit a duration in which at least two or more of the heater electrodes are simultaneously powerable by the battery power source.

15 **[0062]** Figure 7 shows a cross-sectional view of an illustrative embodiment of an arm 700 of a hair styling appliance. The arm 700 comprises an outer casing 712 to which other components of the hair styling appliance are secured. A heater element 704 is positioned on heater plate 702 to form a hair styling heater assembly. The hair styling heater assembly is then retained on the arm by the use of a thermally insulating support structure 714.

20 **[0063]** The heater plate 702 comprises a styling surface 715 on one side that contacts the hair to be styled during use. On the other side of the heater plate two L-shaped recesses 709a, 709b provide sockets for securely fixing the hair styling heater assembly to the thermally insulating support structure 714.

25 **[0064]** The thermally insulating support structure 714 is formed from insulating material and may, for example, be constructed from a similar material to the casing. The support structure 714 comprises a pair of L-shaped projections 708a, 708b arranged to fit into the 709a, 709b recesses in the heater plate 702 and couple the heater plate and support structure together. To allow the projections to fit into the recesses, they may have a small degree of flex such that then can snap-fit into the recesses, thereby securely fixing the heater plate and support structure together. It will be appreciated however that other means for coupling the hair styling heater assembly and the support structure are possible, and the example shown in Figure 15 is purely illustrative of one way of doing so.

30 **[0065]** To secure the support structure 714 to the casing, sprinted members 710a and 710b are used. These are secured at one end to the casing and at the other end to the support structure. In the illustrative embodiment shown in Figure 15, compression springs are used which bias the heater assembly and support structure away from the arm. These allow the heater plate to move relative to the casing during styling, allowing the plates to retain contact with varying thicknesses and changes in the profile of hair clamped between opposing pairs of styling surfaces on the heater plates. It will be appreciated that various other arrangements may be used that provide allow for movement of the heater plates.

35 **[0066]** This heater assembly arrangement provides several advantages:

40 1. Firstly, it reduces the width of the outer casing needed to retain the hair styling heater assembly as no retaining lugs or fixings are now needed at the sides of the heater assembly.

45 2. Secondly, with no protrusions extending to one or more sides of the heater plate 702, the widest part of the heater plate is the styling surface 715. Such an arrangement is particularly advantageous during manufacturing as it allows the heater plates to be closely packed, with no or minimal gap between them. This allows a large number of styling surfaces to be screen printed, as if they were one large surface, improving the efficiency of the printing process.

50 **[0067]** The skilled person will appreciate that the techniques we have described above may be employed for a range of hair styling appliances including, but not limited to, a hair straightener, a hair crimping device, and a hair curler. The skilled person would also appreciate that features from many of the embodiments are interchangeable and not limited to the specific embodiment they are described in relation to.

55 **[0068]** No doubt many other effective alternatives will occur to the skilled person. It will be understood that the invention is not limited to the described embodiments and encompasses modifications apparent to those skilled in the art lying within the scope of the claims appended hereto.

Claims

1. A hair styling apparatus comprising:

5 a plurality of heater electrodes which heat one or more hair styling heaters, the plurality of heater electrodes comprising a first subset and a second subset;
a power source for powering the plurality of heater electrodes and
a controller (506) configured to control powering of the plurality of heater electrodes from the power source
10 wherein, in a first mode of operation, the controller is configured to control the power source so that the first and second subsets of the plurality of heater electrodes are not simultaneously powered and are powered in a time interleaved manner multiple times per second.

15 2. A hair styling apparatus according to claim 1, wherein the controller is configured to select the first and second subsets so that a total current drawn by each of the first and second subsets is below a predetermined current threshold.

3. A hair styling apparatus according to any one of the preceding claims, wherein no heater electrodes are selected for both the first and second subsets.

20 4. A hair styling apparatus according to claim 3, wherein the controller is configured to switch the power source between the first and second subsets multiple times per second.

25 5. A hair styling apparatus according to any one of the preceding claims, wherein the controller is configured to alternate between the first mode of operation and a second mode of operation in which the first and second subsets of the plurality of heater electrodes are simultaneously powered.

30 6. A hair styling apparatus according to claim 5, wherein the controller is configured to switch from the second mode of operation to the first mode of operation in response to a control signal such as a predetermined amount of time in the second mode of operation has elapsed.

7. A hair styling apparatus according to claim 5 or claim 6, wherein the power source is a battery source and the hair styling apparatus further comprises a battery temperature sensor which senses the temperature of the battery source and which sends a battery temperature sense signal to the controller.

35 8. A hair styling apparatus according to claim 7, wherein the battery temperature sense signal is compared to a battery temperature threshold and the control signal is generated when the battery temperature sense signal is greater than the battery temperature threshold.

40 9. A hair styling apparatus according to any one of claims 5 to 8, further comprising a temperature sensor for sensing ambient temperature; and wherein said control signal is generated when the sensed ambient temperature is below a threshold ambient temperature.

45 10. A hair styling apparatus according to any one of the preceding claims, comprising a touch sensitive switch configured to enable or disable the hair styling apparatus.

50 11. A hair styling apparatus according to claim 10, comprising a first arm having a first contacting surface and a second arm having a second contacting surface, wherein the arms are moveable between a closed position in which the first and second contacting surfaces are adjacent and an open position in which the first and second contacting surfaces are spaced apart and wherein the touch sensitive switch is located on the first or second contacting surface, or wherein when the arms are in the closed position, the touch sensitive switch is deactivated, or wherein the controller is configured to determine when a user has activated said touch sensitive switch for at least a predetermined duration of time and enable or disable the hair styling apparatus responsive to said determining.

55 12. A hair styling apparatus according to any preceding claim, wherein, in the first mode of operation, the controller is configured to control the powering of the heater electrodes using predefined heating cycles during one or more of which power is provided, at different times, to the first and second subsets of the plurality of heaters, and preferably wherein the heating cycles have a duration of between 100 μ s and 500ms.

- 5 13. A hair styling apparatus according to any preceding claim, wherein the controller is configured to use pulse width modulation, PWM, power control to control the delivery of power to the first and second subsets such that, during the first mode of operation, the controller is configured to generate power control signals for the first and second subsets to cause power to be delivered to the first and second subsets at different times within each of one or more heating cycles of the PWM power control.
- 10 14. A method of controlling a hair styling apparatus according to any preceding claim comprising a plurality of heater electrodes which heat one or more hair styling heaters, the plurality of heaters comprising a first subset and a second subset; the method comprising:
controlling powering of the heater electrodes so that the first and second subsets of the plurality of heaters are not simultaneously powered and are powered in a time interleaved manner multiple times per second.

Patentansprüche

- 15 1. Haarformvorrichtung, die Folgendes umfasst:

mehrere Heizelektroden, die ein oder mehrere Haarformheizelemente erhitzen, wobei die mehreren Heizelektroden eine erste und eine zweite Teilmenge umfassen,
20 eine Stromquelle zum Versorgen der mehreren Heizelektroden mit Strom und eine Steuerung (506), die so konfiguriert ist, dass sie das Versorgen der mehreren Heizelektroden mit Strom steuert,
wobei die Steuerung so konfiguriert ist, dass sie die Stromquelle in einem ersten Betriebsmodus so steuert, dass die erste und die zweite Teilmenge der mehreren Heizelektroden nicht gleichzeitig, sondern auf zeitlich versetzte Weise mehrmals pro Sekunde mit Strom versorgt werden.

- 25 2. Haarformvorrichtung nach Anspruch 1, wobei die Steuerung so konfiguriert ist, dass sie die erste und die zweite Teilmenge so auswählt, dass ein von beiden bezogener Gesamtstrom unter einem vorgegebenen Stromgrenzwert liegt.

- 30 3. Haarformvorrichtung nach einem der vorhergehenden Ansprüche, wobei sowohl für die erste als auch für die zweite Teilmenge keine Heizelektroden ausgewählt sind.

- 35 4. Haarformvorrichtung nach Anspruch 3, wobei die Steuerung so konfiguriert ist, dass sie die Stromquelle zwischen der ersten und der zweiten Teilmenge mehrmals pro Sekunde umschaltet.

- 40 5. Haarformvorrichtung nach einem der vorhergehenden Ansprüche, wobei die Steuerung so konfiguriert ist, dass sie zwischen dem ersten Betriebsmodus und einem zweiten Betriebsmodus, in dem die erste und die zweite Teilmenge der mehreren Heizelektroden gleichzeitig mit Strom versorgt werden, wechselt.

- 45 6. Haarformvorrichtung nach Anspruch 5, wobei die Steuerung so konfiguriert ist, dass sie als Reaktion auf ein Steuersignal, wie beispielsweise das Verstreichen eines vorgegebenen Zeitraums im zweiten Betriebsmodus, aus dem zweiten Betriebsmodus in den ersten Betriebsmodus wechselt.

- 50 7. Haarformvorrichtung nach Anspruch 5 oder 6, wobei es sich bei der Stromquelle um eine Batteriequelle handelt und die Haarformvorrichtung ferner einen Batterietemperatursensor umfasst, der die Temperatur der Batteriequelle misst und ein Batterietemperaturmesssignal zur Steuerung sendet.

- 55 8. Haarformvorrichtung nach Anspruch 7, wobei das Batterietemperaturmesssignal mit einem Batterietemperaturgrenzwert verglichen und das Steuersignal erzeugt wird, wenn das Batterietemperaturmesssignal den Batterietemperaturgrenzwert übersteigt.

9. Haarformvorrichtung nach einem der Ansprüche 5 bis 8, die ferner einen Temperatursensor zum Messen der Umgebungstemperatur umfasst und wobei das Steuersignal erzeugt wird, wenn die gemessene Umgebungstemperatur unter einem Grenzwert für die Umgebungstemperatur liegt.

10. Haarformvorrichtung nach einem der vorhergehenden Ansprüche, die einen Kontaktschalter umfasst, der so konfiguriert ist, dass er die Haarformvorrichtung ein- oder ausschaltet.

- 5 11. Haarformvorrichtung nach Anspruch 10, die einen ersten Arm mit einer ersten Kontaktfläche und einen zweiten Arm mit einer zweiten Kontaktfläche umfasst, wobei sich die Arme zwischen einer geschlossenen Position, in der die erste und die zweite Kontaktfläche aneinander anliegen, und einer offenen Position, in der die erste und die zweite Kontaktfläche voneinander beabstandet sind, bewegen lassen und sich der Kontaktschalter an der ersten oder der zweiten Kontaktfläche befindet oder der Kontaktschalter, wenn sich die Arme in der geschlossenen Position befinden, ausgeschaltet ist oder die Steuerung so konfiguriert ist, dass sie erfasst, wenn ein Benutzer den Kontaktschalter für zumindest einen vorgegebenen Zeitraum betätigt hat, und die Haarformvorrichtung als Reaktion auf das Erfassen ein- oder ausschaltet.
- 10 12. Haarformvorrichtung nach einem vorhergehenden Anspruch, wobei die Steuerung so konfiguriert ist, dass sie im ersten Betriebsmodus das Versorgen der Heizelektroden mit Strom unter Verwendung von vordefinierten Heizzyklen steuert, wobei die erste und die zweite Teilmenge der mehreren Heizelemente in einem oder mehreren dieser Heizzyklen zu verschiedenen Zeiten mit Strom versorgt werden und die Heizzyklen vorzugsweise eine Dauer von 100 μ s bis 500 ms haben.
- 15 13. Haarformvorrichtung nach einem vorhergehenden Anspruch, wobei die Steuerung so konfiguriert ist, dass sie eine Leistungsregelung per Pulsbreitenmodulation (PBM) zum Regeln des Einspeisens von Strom in die erste und die zweite Teilmenge verwendet, so dass die Steuerung so konfiguriert ist, dass sie im ersten Betriebsmodus Leistungsregelsignale für die erste und die zweite Teilmenge erzeugt, damit zu verschiedenen Zeiten in jedem des einen oder der mehreren Heizzyklen der PBM-Leistungsregelung Strom in die erste und die zweite Teilmenge eingespeist wird.
- 20 14. Verfahren zum Steuern einer Haarformvorrichtung nach einem vorhergehenden Anspruch mit mehreren Heizelektroden, die ein oder mehrere Haarformheizelemente erhitzen, wobei die mehreren Heizelemente eine erste und eine zweite Teilmenge umfassen, wobei das Verfahren Folgendes umfasst:
derartiges Steuern des Versorgens der Heizelektroden mit Strom, dass die erste und die zweite Teilmenge der mehreren Heizelemente nicht gleichzeitig, sondern auf zeitlich versetzte Weise mehrmals pro Sekunde mit Strom versorgt werden.

30

Revendications

1. Appareil de coiffure comprenant :
- 35 une pluralité d'électrodes d'élément chauffant qui chauffent un ou plusieurs éléments chauffant de coiffure, la pluralité d'électrodes d'élément chauffant comprenant un premier sous-groupe et un deuxième sous-groupe ; une source d'alimentation pour alimenter la pluralité d'électrodes d'élément chauffant et un dispositif de commande (506) configuré pour commander l'alimentation de la pluralité d'électrodes d'élément chauffant depuis la source d'alimentation dans lequel, dans un premier mode de fonctionnement, le dispositif de commande est configuré pour commander la source d'alimentation de sorte que les premier et deuxième sous-groupes de la pluralité d'électrodes d'élément chauffant ne sont pas alimentées simultanément et sont alimentées de manière intercalée dans le temps plusieurs fois par seconde.
- 40
2. Appareil de coiffure selon la revendication 1, dans lequel le dispositif de commande est configuré pour sélectionner les premier et deuxième sous-groupes de sorte qu'un courant total tiré par chacun des premier et deuxième sous-groupes est inférieur à un seuil de courant prédéterminé.
- 45
3. Appareil de coiffure selon l'une quelconque des revendications précédentes, dans lequel aucune électrode d'élément chauffant n'est sélectionnée pour les deux premier et deuxième sous-groupes.
- 50
4. Appareil de coiffure selon la revendication 3, dans lequel le dispositif de commande est configuré pour commuter la source d'alimentation entre les premier et deuxième sous-groupes plusieurs fois par seconde.
- 55
5. Appareil de coiffure selon l'une quelconque des revendications précédentes, dans lequel le dispositif de commande est configuré pour alterner entre le premier mode de fonctionnement et un deuxième mode de fonctionnement dans lequel les premier et deuxième sous-groupes de la pluralité d'électrodes d'élément chauffant sont alimentés simultanément.

EP 3 258 812 B2

6. Appareil de coiffure selon la revendication 5, dans lequel le dispositif de commande est configuré pour commuter du deuxième mode de fonctionnement au premier mode de fonctionnement en réponse à un signal de commande tel qu'une quantité prédéterminée de temps dans le deuxième mode de fonctionnement qui s'est écoulée.
- 5 7. Appareil de coiffure selon la revendication 5 ou la revendication 6, dans lequel la source d'alimentation est une source d'alimentation par pile et l'appareil de coiffure comprend en outre un capteur de température de pile qui capte la température de la source d'alimentation par pile et qui envoie un signal de détection de température de pile au dispositif de commande.
- 10 8. Appareil de coiffure selon la revendication 7, dans lequel le signal de détection de température de pile est comparé à un seuil de température de pile et le signal de commande est généré quand le signal de détection de température de pile est supérieur au seuil de la température de pile.
- 15 9. Appareil de coiffure selon l'une quelconque des revendications 5 à 8, comprenant en outre un capteur de température pour détecter la température ambiante ; et dans lequel ledit signal de commande est généré quand la température ambiante détectée est inférieure à une température ambiante seuil.
- 20 10. Appareil de coiffure selon l'une quelconque des revendications précédentes, comprenant un commutateur à effleurement configuré pour mettre en service ou mettre hors service l'appareil de coiffure.
- 25 11. Appareil de coiffure selon la revendication 10, comprenant un premier bras ayant une première surface de contact et un deuxième bras ayant une deuxième surface de contact, dans lequel les bras sont mobiles entre une position fermée dans laquelle les première et deuxième surfaces de contact sont adjacentes et une position ouverte dans laquelle les première et deuxième surfaces de contact sont espacées et dans lequel le commutateur à effleurement est situé sur la première ou deuxième surface de contact, ou dans lequel quand les bras sont dans la position fermée, le commutateur à effleurement est désactivé, ou dans lequel le dispositif de commande est configuré pour déterminer quand un utilisateur a activé ledit commutateur à effleurement pendant au moins une durée de temps prédéterminée et mettre en service ou mettre hors service l'appareil de coiffage en réponse à ladite détermination.
- 30 12. Appareil de coiffure selon l'une quelconque des revendications précédentes, dans lequel, dans le premier mode de fonctionnement, le dispositif de commande est configuré pour commander l'alimentation des électrodes d'élément chauffant en utilisant des cycles de chauffage prédéfinis pendant un ou plusieurs desquels du courant est fourni, à des moments différents, aux premier et deuxième sous-groupes de la pluralité d'éléments chauffants, et de préférence dans lequel les cycles de chauffage ont une durée entre 100 μ s et 500 ms.
- 35 13. Appareil de coiffure selon l'une quelconque des revendications précédentes, dans lequel le dispositif de commande est configuré pour utiliser la commande d'alimentation par modulation de largeur d'impulsion, PWM, pour commander la distribution de courant aux premier et deuxième sous-groupes de sorte que, pendant le premier mode de fonctionnement, le dispositif de commande est configuré pour générer des signaux de commande de courant pour les premier et deuxième sous-groupes pour permettre que du courant soit distribué aux premier et deuxième sous-groupes à des moments différents dans chacun des un ou plusieurs cycles de chauffage de la commande de courant par PWM.
- 40 14. Procédé de commande d'un appareil de coiffure selon l'une quelconque des revendications précédentes comprenant une pluralité d'électrodes d'élément chauffant qui chauffent un ou plusieurs éléments chauffants de coiffure, la pluralité d'éléments chauffants comprenant un premier sous-groupe et un deuxième sous-groupe ; le procédé comprenant :
- 45 la commande de l'alimentation des électrodes d'élément chauffant de sorte que les premier et deuxième sous-groupes de la pluralité d'éléments chauffants ne sont pas alimentés simultanément et sont alimentés de manière
- 50 intercalée dans le temps plusieurs fois par seconde.
- 55

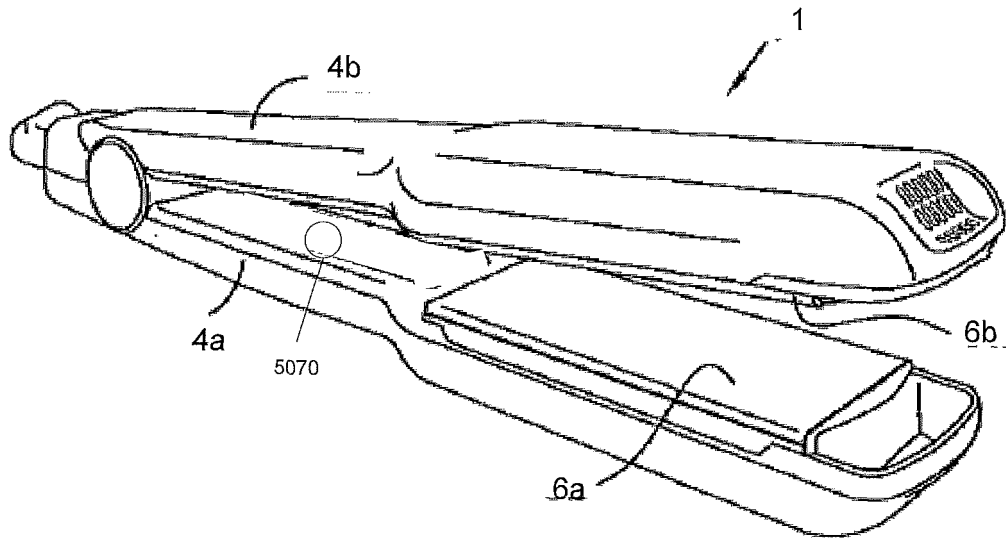

Figure 1

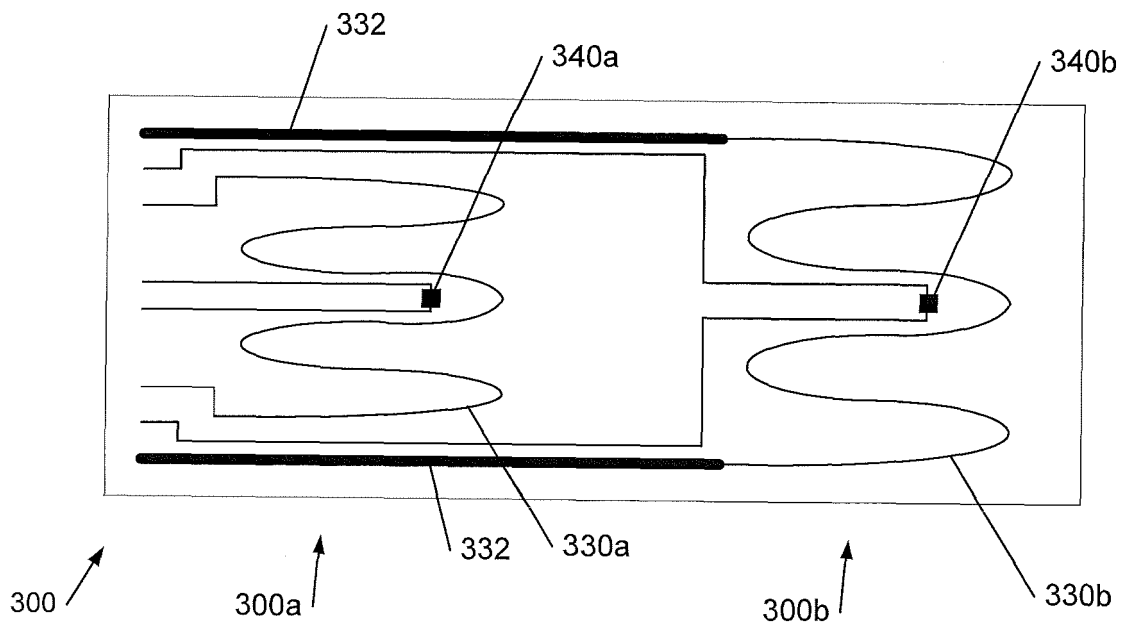
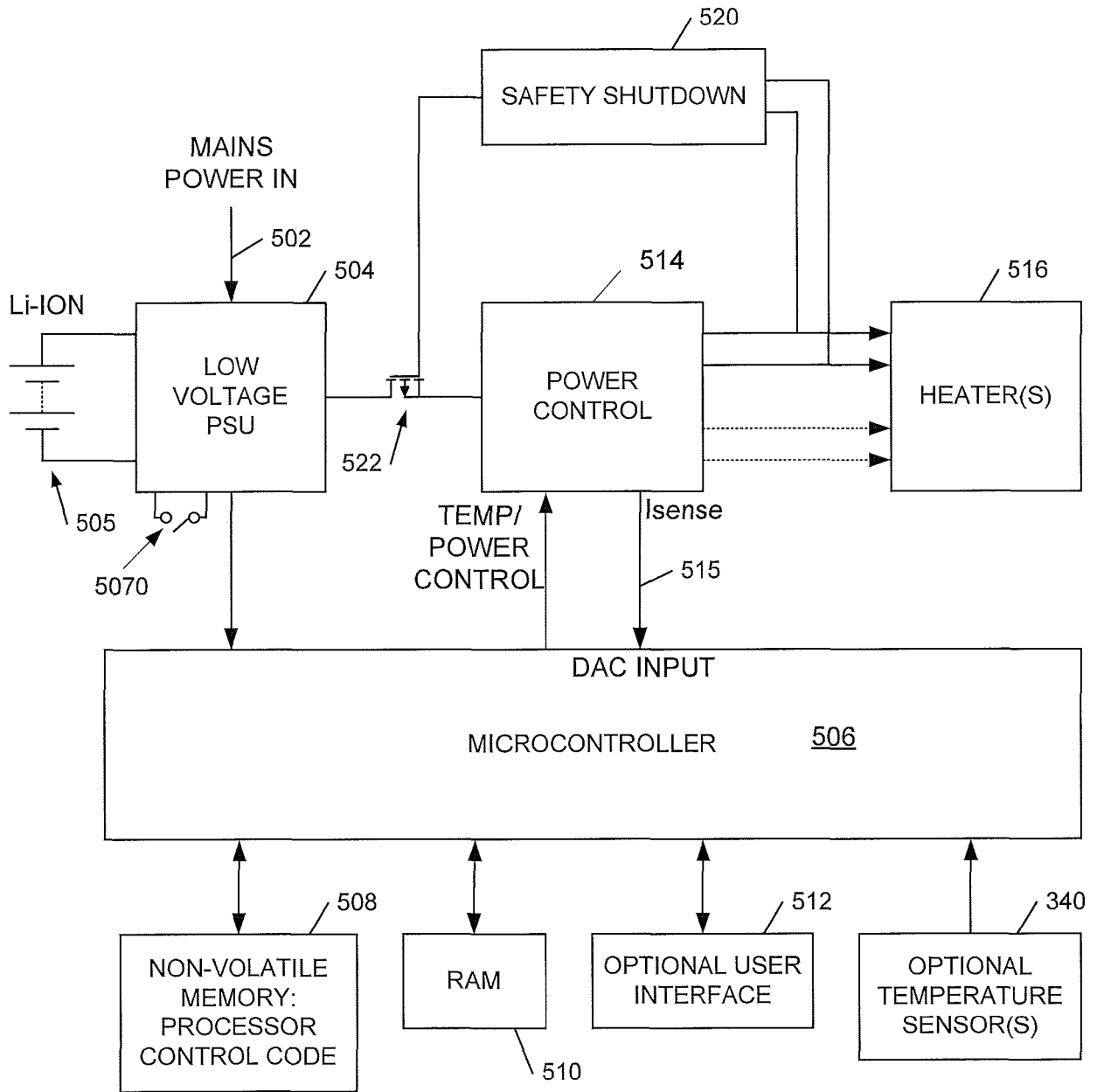

Figure 3



500 ↗

Figure 2

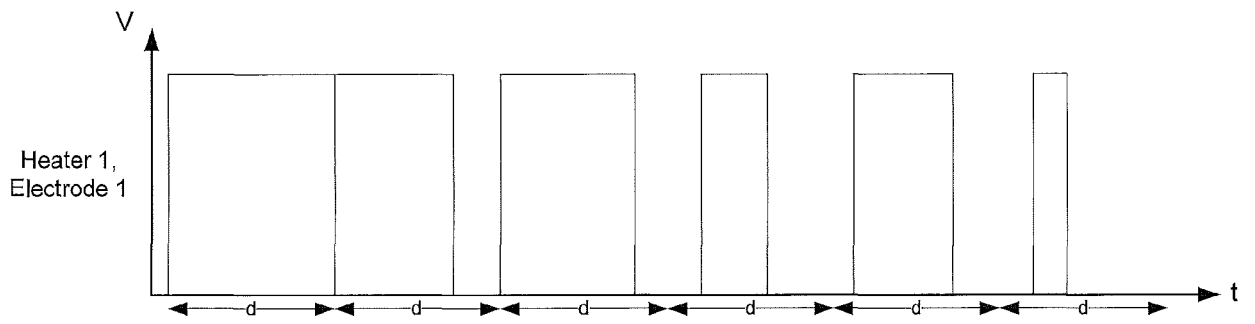

Figure 4a

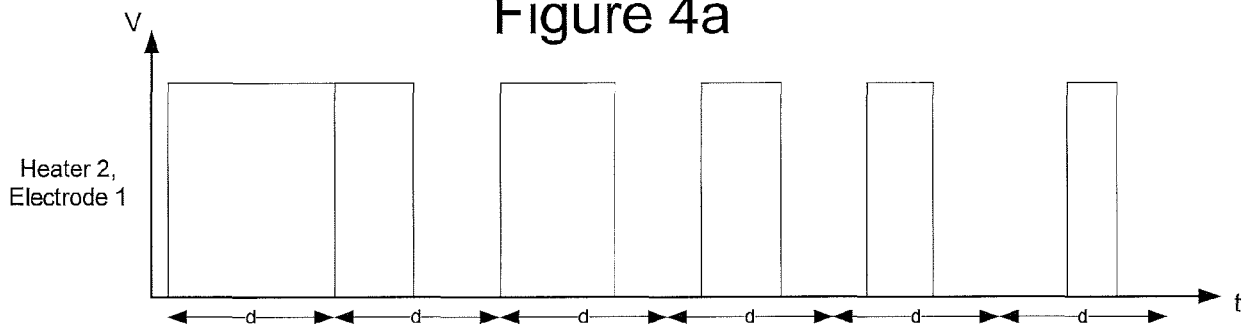

Figure 4b

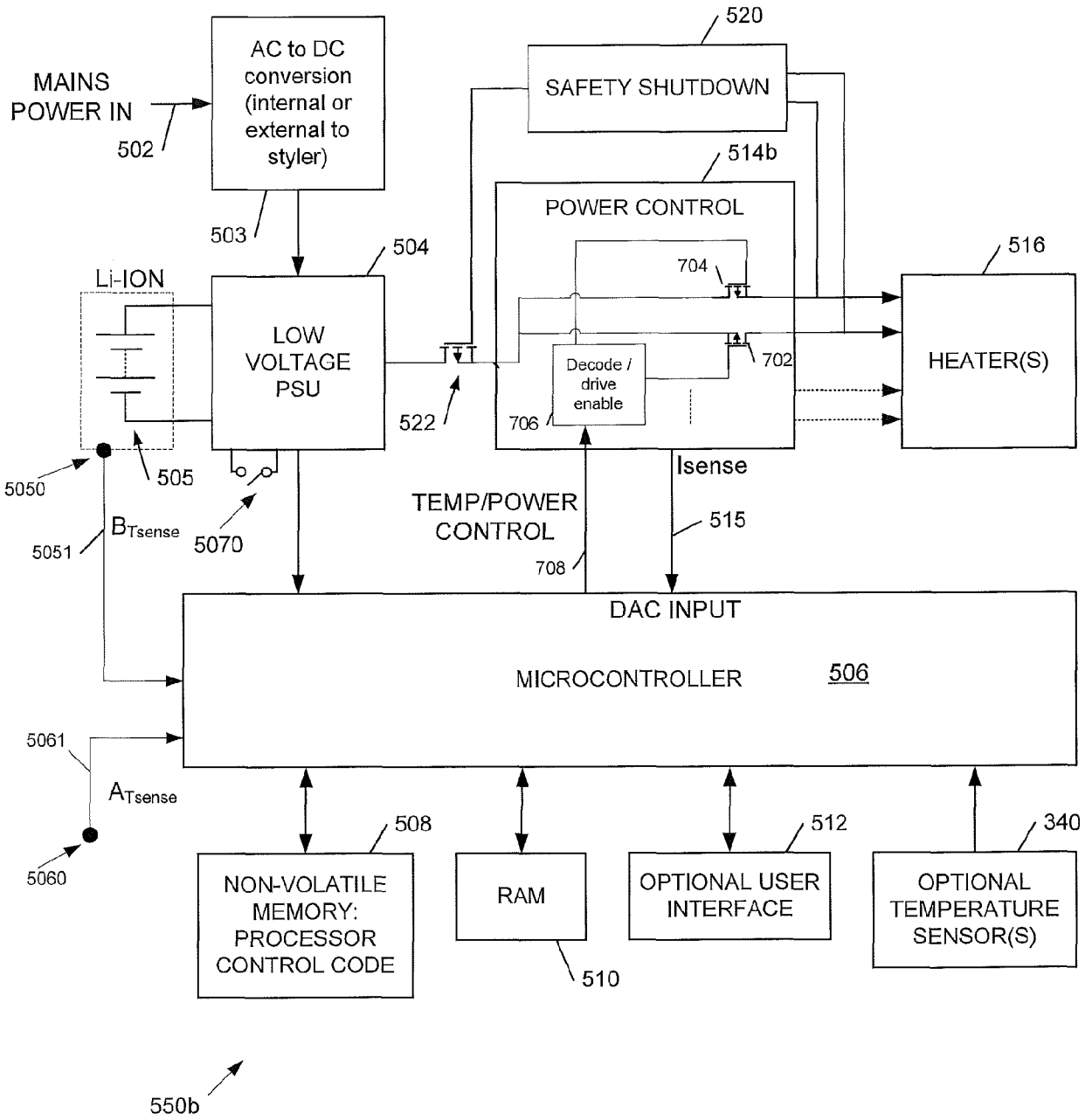

Figure 5

Figure 6a

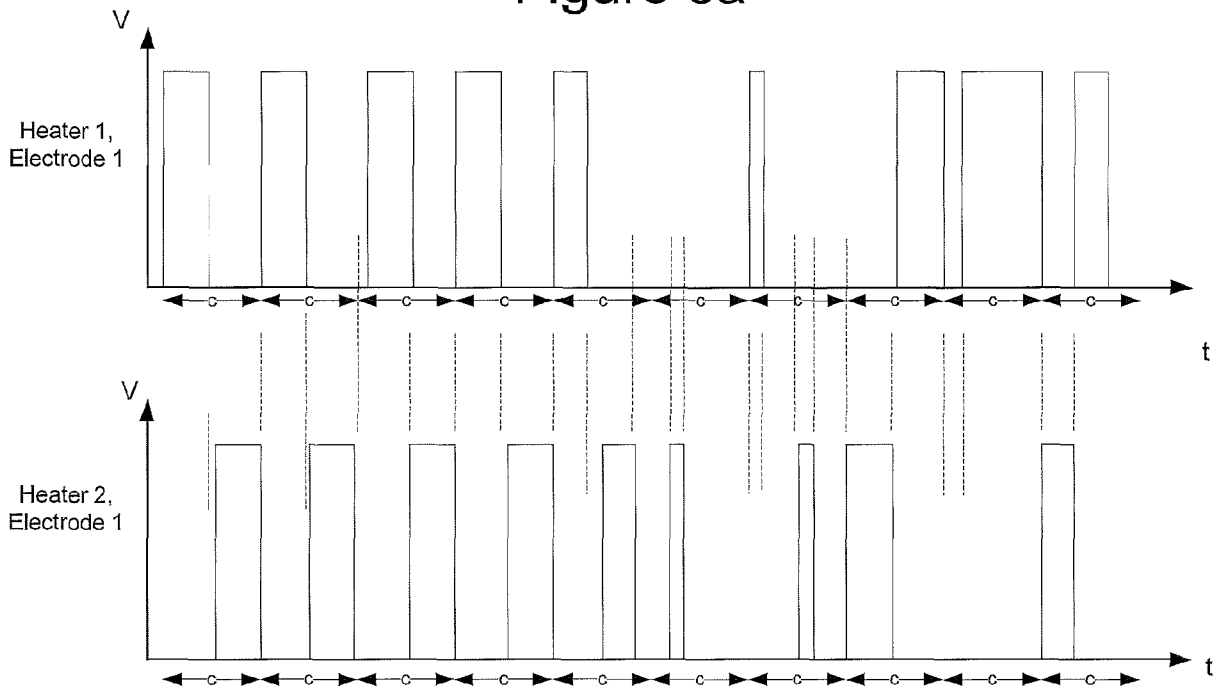

Figure 6b

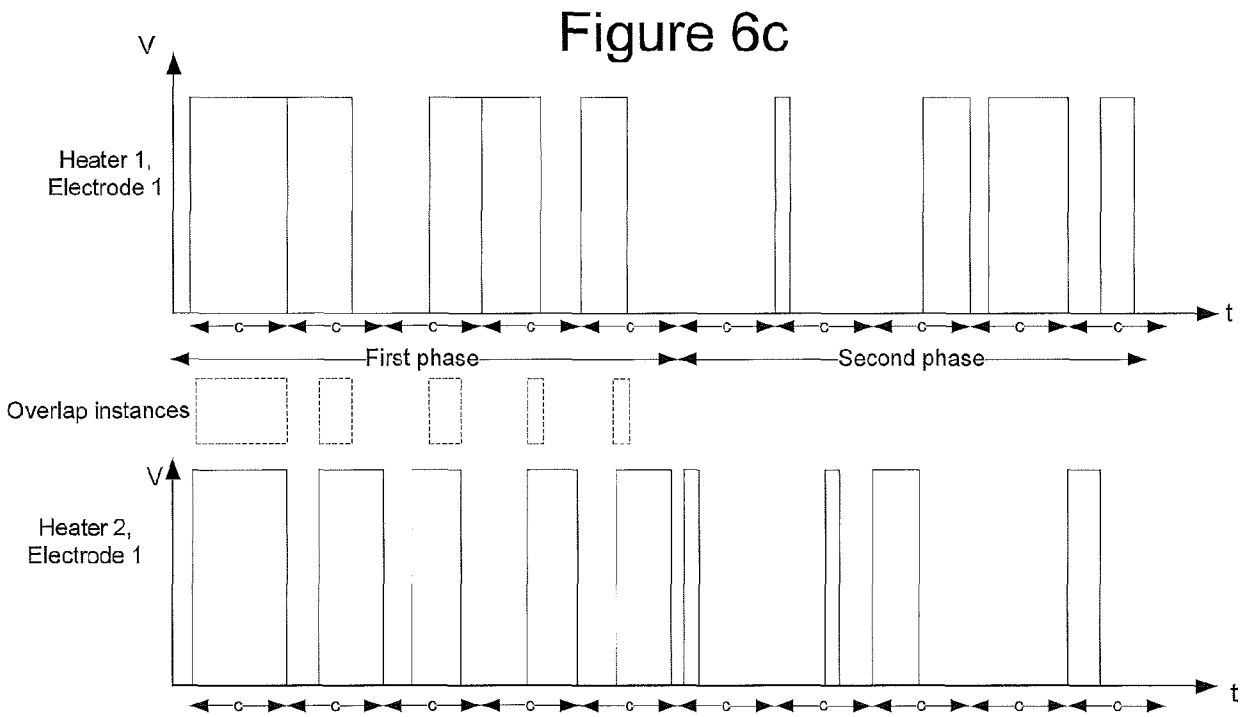

Figure 6d

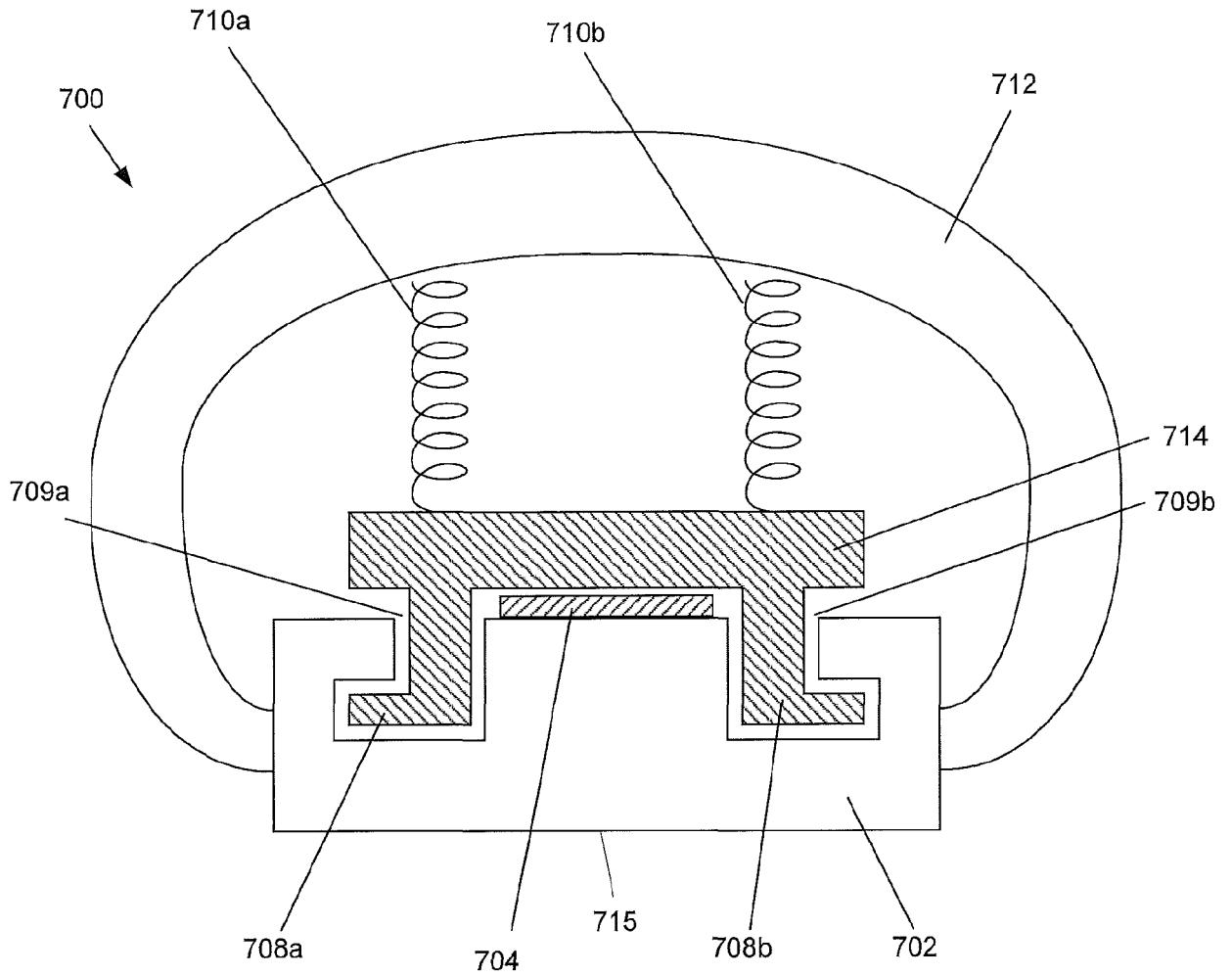

Figure 7

REFERENCES CITED IN THE DESCRIPTION

This list of references cited by the applicant is for the reader's convenience only. It does not form part of the European patent document. Even though great care has been taken in compiling the references, errors or omissions cannot be excluded and the EPO disclaims all liability in this regard.

Patent documents cited in the description

- GB 2477834 A [0005] [0054]
- WO 2014001769 A [0005] [0037]
- GB 2503521 A [0005] [0037]