



(11) **EP 3 266 331 B1**

(12) **EUROPEAN PATENT SPECIFICATION**

(45) Date of publication and mention of the grant of the patent:
01.05.2019 Bulletin 2019/18

(51) Int Cl.:
A44B 17/00 (2006.01)

(21) Application number: **17178563.7**

(22) Date of filing: **29.06.2017**

(54) **PRESSURE-OPERATED CLOSURE DEVICE**

DRUCKBETRIEBENE VERSCHLUSSVORRICHTUNG

DISPOSITIF DE FERMETURE ACTIONNÉ PAR PRESSION

(84) Designated Contracting States:
AL AT BE BG CH CY CZ DE DK EE ES FI FR GB GR HR HU IE IS IT LI LT LU LV MC MK MT NL NO PL PT RO RS SE SI SK SM TR

(30) Priority: **04.07.2016 IT 201600068993**

(43) Date of publication of application:
10.01.2018 Bulletin 2018/02

(73) Proprietor: **Metal P. di Paris G. & C. S.r.l.**
24064 Grumello del Monte (BG) (IT)

(72) Inventor: **PARIS, Giuseppe**
24064 GRUMELLO DEL MONTE BG (IT)

(74) Representative: **Modiano, Micaela Nadia et al**
Modiano & Partners
Via Meravigli, 16
20123 Milano (IT)

(56) References cited:
DE-T5-112009 001 991 FR-A- 995 414
US-A- 1 897 936 US-A- 2 546 716

EP 3 266 331 B1

Note: Within nine months of the publication of the mention of the grant of the European patent in the European Patent Bulletin, any person may give notice to the European Patent Office of opposition to that patent, in accordance with the Implementing Regulations. Notice of opposition shall not be deemed to have been filed until the opposition fee has been paid. (Art. 99(1) European Patent Convention).

Description

[0001] The present invention relates to a snap-acting or pressure-operated closure device, particularly for items of clothing or articles of leather goods and the like.

[0002] Currently snap-acting press-studs are known in the clothing sector, in the leather goods sector, and also in various other sectors.

[0003] Press-studs generally have a female element in which a cavity is provided inside which a C-shaped retention spring is accommodated, and a male element, with a circular undercut portion, which is configured to be inserted into the cavity of the female element, and be held there, by way of the C-shaped spring which engages with its circular undercut portion. The action of pressing the male element into the female element, exerted by the user, entails the momentary elastic expansion, or opening, of the C-shaped spring, and the passing through thereof by the male element, until the C-shaped spring closes onto the circular undercut portion of the male element, retaining it in the cavity of the female element.

[0004] Both the male element and the female element are fixed to the respective flaps of fabric by what are known as "complementary elements".

[0005] In conventional press-studs, the complementary elements comprise a protruding portion made of sheet metal, generally brass, substantially cylindrical and hollow, which passes through a hole provided in the flap of fabric and through a hole provided in the female or male element. The fixing between the female or male element and the complementary element is obtained by riveting the protruding portion of the sheet metal around the edges of the hole of the female or male element.

[0006] Such conventional buttons however have the unpleasant drawback that the riveted and gathered portion of sheet metal remains visible through the cavity of the female element.

[0007] In substance, when the press-stud, applied to an item of clothing, is not closed, then on the outside of the item of clothing the female component presents the desired cap appearance associated with the complementary element, but on the inside of the press-stud, which is designed to face the locking body of the male component, the female component presents an unaesthetic surface where the portion of sheet metal that has been riveted and gathered is clearly visible.

[0008] Such conventional buttons are not devoid of drawbacks, which include, first of all, the aesthetic defect described above.

[0009] FR 995 414 discloses a pressure-operated closure device as defined in the preamble of claim 1.

[0010] The aim of the present invention consists of providing a pressure-operated closure device that compensates for the drawbacks of the known art.

[0011] Within this aim, an object of the present invention is to provide a pressure-operated closure device that is easy to make, and economically competitive when compared to the known art.

[0012] Another object of the present invention consists of providing a pressure-operated closure device that is more versatile and better indicated for an ability to engrave customizations on the visible faces.

[0013] Another object of the present invention consists of providing a pressure-operated closure device that is more prized and luxurious, in particular from the point of view of the manufacturing finishing of its components.

[0014] Another object of the present invention consists in providing a pressure-operated closure device that is capable of offering the widest guarantees of reliability and safety in use.

[0015] This aim and these and other objects which will become better apparent hereinafter are achieved by a pressure-operated closure device that comprises the features of claim 1.

[0016] Further characteristics and advantages of the invention will become better apparent from the detailed description of a preferred, but not exclusive, embodiment of a pressure-operated closure device, which is illustrated by way of non-limiting example with the aid of the accompanying drawings wherein:

Figure 1 is an exploded perspective view of an embodiment of a pressure-operated closure device, according to the invention;

Figure 2 is a cross-sectional side view of the device of Figure 1, according to the invention, shown in the open configuration;

Figure 3 is a cross-sectional side view of the device of Figure 1, according to the invention, shown in the closed configuration;

Figure 4 is an exploded perspective view of a variation of the pressure-operated closure device of Figure 1, according to the invention;

Figure 5 is a cross-sectional side view of the device of Figure 4, according to the invention, shown in the open configuration;

Figure 6 is a cross-sectional side view of the device of Figure 4, according to the invention, shown in the closed configuration;

Figure 7 shows a variation of a fixing element of the device in Figure 1, according to the invention;

Figure 8 shows a variation of a fixing element of the device of Figure 4, according to the invention;

Figure 9 is a perspective view of the female component of a pressure-operated closure device, according to the invention.

[0017] With reference to the figures, the pressure-operated closure device, generally designated by the reference numeral 1, comprises:

- a female element 2 in which a cavity 3 is formed,
- a male element 4, which comprises a locking body 5 that is configured to be inserted into the cavity 3,
- a first complementary element 6 fixed to the female element 2 so as to retain a first flap 7 of a fabric,

- a second complementary element 8 configured to be fixed to the male element 4 so as to retain a second flap 9 of a fabric.

[0018] According to the invention, the device 1 comprises a fixing element 10 which comprises a cap 11, which is visible through the cavity 3 of the female element 2, and fixing means 12.

[0019] The cap 11 retains the female element 2, while the fixing means 12 fix the cap 11 and the female element 2 to the first complementary element 6.

[0020] Advantageously therefore, the first flap 7 of a fabric is arranged between the female element 2 and the first complementary element 6. The fixing element 10 passes through the female element 2 and the first flap 7 and enables the fixing of the female element 2 to the first complementary element 6, by virtue of the retaining action carried out by the cap 11 and by the fixing means 12.

[0021] The fixing element 10 substantially has the shape of a stud.

[0022] Advantageously, an annular seat 13 is defined in the cavity 3 of the female element 2, which accommodates means 14 of elastic retention of the locking body 5 of the male element 4. The elastic retention means 14 also have the function of keeping the cap 11 in the cavity 3.

[0023] This makes it possible to stably pre-assemble the female element 2 to the fixing element 10 so as to be able to ship and distribute the set of the two components as a semi-finished product.

[0024] The elastic retention means 14 are advantageously constituted by a C-shaped retention spring.

[0025] For the locking device 1 to operate correctly, it is important that the retention means 14 are accommodated in the annular seat 13 with a tolerance that, on the one hand, allows the retention means 14 to expand during the step when the locking body 5 is passing through, and which, on the other hand, prevents the retention means 5 from exiting from the annular seat 13.

[0026] The dimensions of the cap (11) are larger than the dimensions of the hole defined by the elastic retention means (14).

[0027] As illustrated by way of example in Figure 2, the fixing element 10, and in particular the cap 11, is slightly larger than the passage hole defined by the C-shaped retention spring.

[0028] The cap 11 has a slightly greater diameter than the diameter of the hole defined by the C-shaped retention spring.

[0029] In order to be capable of being inserted into the cavity 3, the fixing element 10 slightly splays the spring, as indicated in Figure 2 by the arrows 25, and, once the cap 11 has passed through the spring, the fixing element 10 remains locked inside the cavity 3.

[0030] Advantageously the cap 11, which has a surface appearance that can be seen through the cavity 3 of the female element 2, can be customized in terms of shapes, dimensions, tooling and materials according to

the requirements of the purchaser.

[0031] For example, a commercial trademark can be printed on the cap 11.

[0032] Advantageously the cap 11 can have a flat visible surface appearance, or one that is convex, or one that is concave.

[0033] Advantageously the female element 2 comprises a through hole 15 which is passed through by the fixing means 12 of the fixing element 10.

[0034] As illustrated with reference to Figures 1, 2 and 3, the fixing means 12 can comprise a pin 16 that is configured to be riveted inside a fixing cavity 17 provided in the first complementary element 6.

[0035] Alternatively, as illustrated in the variation of the device 1 shown in Figures 4, 5 and 6, the fixing means 12 can comprise a fixing cavity 18 that is configured to receive a pin 19 provided in the first complementary element 6, the pin 19 being riveted inside the fixing cavity 18.

[0036] The fixing element 10 can be provided in a single piece, or in two pieces assembled together, as shown in Figures 7 and 8.

[0037] For example the cap 11 can be fixed to the fixing means 12, i.e. to the pin 16 or to the walls that define the cavity 18, by folding its peripheral edge.

[0038] The elastic retention means 14 are advantageously adapted to engage an undercut portion 20 of the locking body 5 of the male element 4, in order to reversibly retain the locking body 5 in the cavity 3 of the female element 2.

[0039] Advantageously the male element 4 comprises a pin 21 that is configured to be riveted inside a fixing cavity 22 provided in the second complementary element 8.

[0040] Alternatively, the fixing cavity can be provided in the male element 4, while the pin can be present in the second complementary element 8.

[0041] The present invention also relates to a female component for a pressure-operated closure device 1 which comprises:

- a female element 2 in which a cavity 3 is formed,
- a first complementary element 6 fixed to the female element 2 so as to retain a first flap 7 of a fabric,
- where the fixing element 10 comprises a cap 11, which is visible through the cavity 3 of the female element 2, and fixing means 12. The cap 11 retains the female element 2, while the fixing means 12 fix the cap 11 and the female element 2 to the first complementary element 6.

[0042] Advantageously the female element 2 can be associated exclusively with the first complementary element 6, with the elastic retention means 14 and with the fixing element 10.

[0043] In other words, the female component is advantageously constituted exclusively by the female element 2, by the first complementary element 6, by the elastic

retention means 14 and by the fixing element 10.

[0044] Figure 9 illustrates only the female component of the pressure-operated closure device, applied to a flap 7 of a fabric. Only the cap 11 is visible through the cavity 3 of the female element 2. The fixing means 12, i.e. pins and fixing cavities, are in fact covered from view by the cap 11. The cap 11 can have, on the visible surface, a desired finish and/or decoration.

[0045] Operation of the pressure-operated closure device is clear and evident from the foregoing description.

[0046] In practice it has been found that the pressure-operated closure device, according to the present invention, achieves the intended aim and objects since it makes it possible to eliminate the aesthetic drawbacks that afflict conventional pressure-operated closure devices.

[0047] Another advantage of the device, according to the invention, consists in that it has components that can easily be assembled together according to conventional procedures.

[0048] Another advantage of the device, according to the invention, consists in that it can be applied to items of clothing according to conventional procedures.

[0049] Another advantage of the device, according to the invention, consists in that the fixing element provided with cap is pre-assembled to the female element, and therefore the female component of the device can be supplied to the end user ready to be applied to the fabric of the item of clothing.

[0050] Another advantage of the pressure-operated closure device, according to the invention, consists in that the fixing of the female element to the respective complementary element, and the consequent retaining of the flap of fabric, are easy to implement and ensure an excellent stability of the female component on the fabric overall.

[0051] The pressure-operated closure device thus conceived is susceptible of numerous modifications and variations, all of which are within the scope of the appended claims.

[0052] Moreover, all the details may be substituted by other, technically equivalent elements.

[0053] In practice the materials employed, provided they are compatible with the specific use, and the contingent dimensions and shapes, may be any according to requirements.

[0054] Where technical features mentioned in any claim are followed by reference signs, those reference signs have been included for the sole purpose of increasing the intelligibility of the claims and accordingly, such reference signs do not have any limiting effect on the interpretation of each element identified by way of example by such reference signs.

Claims

1. A pressure-operated closure device (1), comprising:

- a female element (2) in which a cavity (3) is formed,

- a male element (4), which comprises a locking body (5) that is configured to be inserted into said cavity (3),

- a first complementary element (6) fixed to said female element (2) so as to retain a first flap (7) of a fabric,

- a second complementary element (8) configured to be fixed to said male element (4) so as to retain a second flap (9) of a fabric,

a fixing element (10) which comprises a cap (11), which is visible through said cavity (3) of said female element (2), and fixing means (12), said cap (11) retaining said female element (2), said fixing means (12) fixing said cap (11) and said female element (2) to said first complementary element (6), in said cavity (3) there being an annular seat (13) in which means (14) are accommodated for the elastic retention of said locking body (5) of said male element (4), said elastic retention means (14) retaining said cap (11) within said cavity (3), **characterized in that** said cap (11) of said fixing element (10) has greater dimensions than the dimensions of the hole defined by said elastic retention means (14).

2. The pressure-operated closure device (1) according to claim 1, **characterized in that** said female element (2) comprises a through hole (15) which is passed through by said fixing means (12) of said fixing element (10).

3. The pressure-operated closure device (1) according to claim 1 or 2, **characterized in that** said fixing means (12) comprise a pin (16) that is configured to be riveted inside a fixing cavity (17) provided in said first complementary element (6).

4. The pressure-operated closure device (1) according to claims 1 or 2, **characterized in that** said fixing means (12) comprise a fixing cavity (18) that is configured to receive a pin (19) provided in said first complementary element (6), said pin (19) being riveted inside said fixing cavity (18).

5. The pressure-operated closure device (1) according to one or more of the preceding claims, **characterized in that** said fixing element (10) is provided in a single piece.

6. The pressure-operated closure device (1) according to one or more of claims 1 to 4, **characterized in that** said cap (11) is fixed to said fixing means (12) by bending the peripheral edge.

7. The pressure-operated closure device (1) according

to one or more of the preceding claims, **characterized in that** said elastic retention means (14) are adapted to engage an undercut portion (20) of said locking body (5) of said male element (4) in order to reversibly retain said locking body (5) of said male element (4) in said cavity (3) of said female element (2).

Patentansprüche

1. Eine druckbetätigte Verschlussvorrichtung (1), die Folgendes umfasst:

- ein aufnehmendes Element (2), in dem ein Hohlraum (3) geformt ist,
- ein vorstehendes Element (4), das einen Verschlusskörper (5) umfasst, der ausgebildet ist, um in den Hohlraum (3) eingesetzt zu werden,
- ein erstes komplementäres Element (6), das an dem aufnehmenden Element (2) befestigt ist, um einen ersten Flügel (7) eines textilen Stoffs zu halten,
- ein zweites komplementäres Element (8), ausgebildet, um an dem vorstehenden Element (4) befestigt zu werden, um einen zweiten Flügel (9) eines textilen Stoffs zu halten,
- ein Befestigungselement (10), das eine Kappe (11), welche durch den Hohlraum (3) des aufnehmenden Elements (2) zu sehen ist, und Befestigungsmittel (12) umfasst, wobei die Kappe (11) das aufnehmende Element (2) hält, das Befestigungsmittel (12) die Kappe (11) und das aufnehmende Element (2) an dem ersten komplementären Element (6) befestigt, wobei sich in dem Hohlraum (3) ein ringförmiger Sitz (13) befindet, in dem Mittel (14) zur elastischen Sicherung des Verschlusskörpers (5) des vorstehenden Elements (4) untergebracht sind, wobei die elastischen Sicherungsmittel (14) die Kappe (11) innerhalb des Hohlraums (3) sichern, **dadurch gekennzeichnet, dass** die Kappe (11) des Befestigungselements (10) größere Abmessungen hat als die Öffnung, die von den elastischen Sicherungsmitteln (14) bestimmt wird.

2. Die druckbetätigte Verschlussvorrichtung (1) gemäß Anspruch 1, **dadurch gekennzeichnet, dass** das aufnehmende Element (2) eine Durchgangsöffnung (15) umfasst, durch welche die Befestigungsmittel (12) des Befestigungselements (10) dringen.

3. Die druckbetätigte Verschlussvorrichtung (1) gemäß Anspruch 1 oder 2, **dadurch gekennzeichnet, dass** die Befestigungsmittel (12) einen Stift (16) umfassen, der ausgebildet ist, um in einen Befestigungshohlraum (17) genietet zu werden, welcher in dem

ersten komplementären Element (6) angebracht ist.

4. Die druckbetätigte Verschlussvorrichtung (1) gemäß Anspruch 1 oder 2, **dadurch gekennzeichnet, dass** die Befestigungsmittel (12) einen Befestigungshohlraum (18) umfassen, der ausgebildet ist, um einen Stift (19) aufzunehmen, der in dem ersten komplementären Element (6) angebracht ist, wobei der Stift (19) in den Befestigungshohlraum (18) eingienietet ist.

5. Die druckbetätigte Verschlussvorrichtung (1) gemäß einem oder mehreren der obigen Ansprüche, **dadurch gekennzeichnet, dass** das Befestigungselement (10) einteilig hergestellt ist.

6. Die druckbetätigte Verschlussvorrichtung (1) gemäß einem oder mehreren der Ansprüche 1 bis 4, **dadurch gekennzeichnet, dass** die Kappe (11) durch Biegen der peripheren Kante an den Befestigungsmitteln (12) befestigt ist.

7. Die druckbetätigte Verschlussvorrichtung (1) gemäß einem oder mehreren der obigen Ansprüche, **dadurch gekennzeichnet, dass** die elastischen Sicherungsmittel (14) ausgebildet sind, um in einen Unterschneidungsabschnitt (20) des Verschlusskörpers (5) des vorstehenden Elements (4) einzugreifen, um den Verschlusskörper (5) des vorstehenden Elements (4) reversibel in dem Hohlraum (3) des aufnehmenden Elements (2) zu sichern.

Revendications

1. Dispositif de fermeture actionné par pression (1), comportant :

- un élément femelle (2) dans lequel une cavité (3) est formée,
- un élément mâle (4), qui comporte un corps de blocage (5) qui est configuré pour être inséré dans ladite cavité (3),
- un premier élément complémentaire (6) fixé audit élément femelle (2) de manière à retenir un premier morceau (7) d'une étoffe,
- un second élément complémentaire (8) configuré pour être fixé audit élément mâle (4) de manière à retenir un second morceau (9) d'une étoffe,
- un élément de fixation (10) qui comporte un capuchon (11), qui est visible à travers ladite cavité (3) dudit élément femelle (2), et des moyens de fixation (12), ledit capuchon (11) retenant ledit élément femelle (2), lesdits moyens de fixation (12) fixant ledit capuchon (11) et ledit élément femelle (2) audit premier élément complémentaire (6), dans ladite cavité (3) étant prévu un

- siège annulaire (13) dans lequel des moyens (14) sont reçus pour la retenue élastique dudit corps de blocage (5) dudit élément mâle (4), lesdits moyens de retenue élastique (14) retenant ledit capuchon (11) à l'intérieur de ladite cavité (3), **caractérisé en ce que** ledit capuchon (11) dudit élément de fixation (10) a des dimensions plus grandes que les dimensions du trou défini par lesdits moyens de retenue élastique (14). 5
10
2. Dispositif de fermeture actionné par pression (1) selon la revendication 1, **caractérisé en ce que** ledit élément femelle (2) comporte un trou traversant (15) à travers lequel passent lesdits moyens de fixation (12) dudit élément de fixation (10). 15
3. Dispositif de fermeture actionné par pression (1) selon la revendication 1 ou 2, **caractérisé en ce que** lesdits moyens de fixation (12) comportent un ergot (16) qui est configuré pour être riveté à l'intérieur d'une cavité de fixation (17) prévue dans ledit premier élément complémentaire (6). 20
4. Dispositif de fermeture actionné par pression (1) selon les revendications 1 ou 2, **caractérisé en ce que** lesdits moyens de fixation (12) comportent une cavité de fixation (18) qui est configurée pour recevoir un ergot (19) prévu dans ledit premier élément complémentaire (6), ledit ergot (19) étant riveté à l'intérieur de ladite cavité de fixation (18). 25
30
5. Dispositif de fermeture actionné par pression (1) selon une ou plusieurs des revendications précédentes, **caractérisé en ce que** ledit élément de fixation (10) est fourni en une seule pièce. 35
6. Dispositif de fermeture actionné par pression (1) selon une ou plusieurs des revendications 1 à 4, **caractérisé en ce que** ledit capuchon (11) est fixé auxdits moyens de fixation (12) en pliant le bord périphérique. 40
7. Dispositif de fermeture actionné par pression (1) selon une ou plusieurs des revendications précédentes, **caractérisé en ce que** lesdits moyens de retenue élastique (14) sont adaptés pour venir en contact avec une partie d'encoche (20) dudit corps de blocage (5) dudit élément mâle (4) afin de retenir de manière réversible ledit corps de blocage (5) dudit élément mâle (4) dans ladite cavité (3) dudit élément femelle (2). 45
50

55

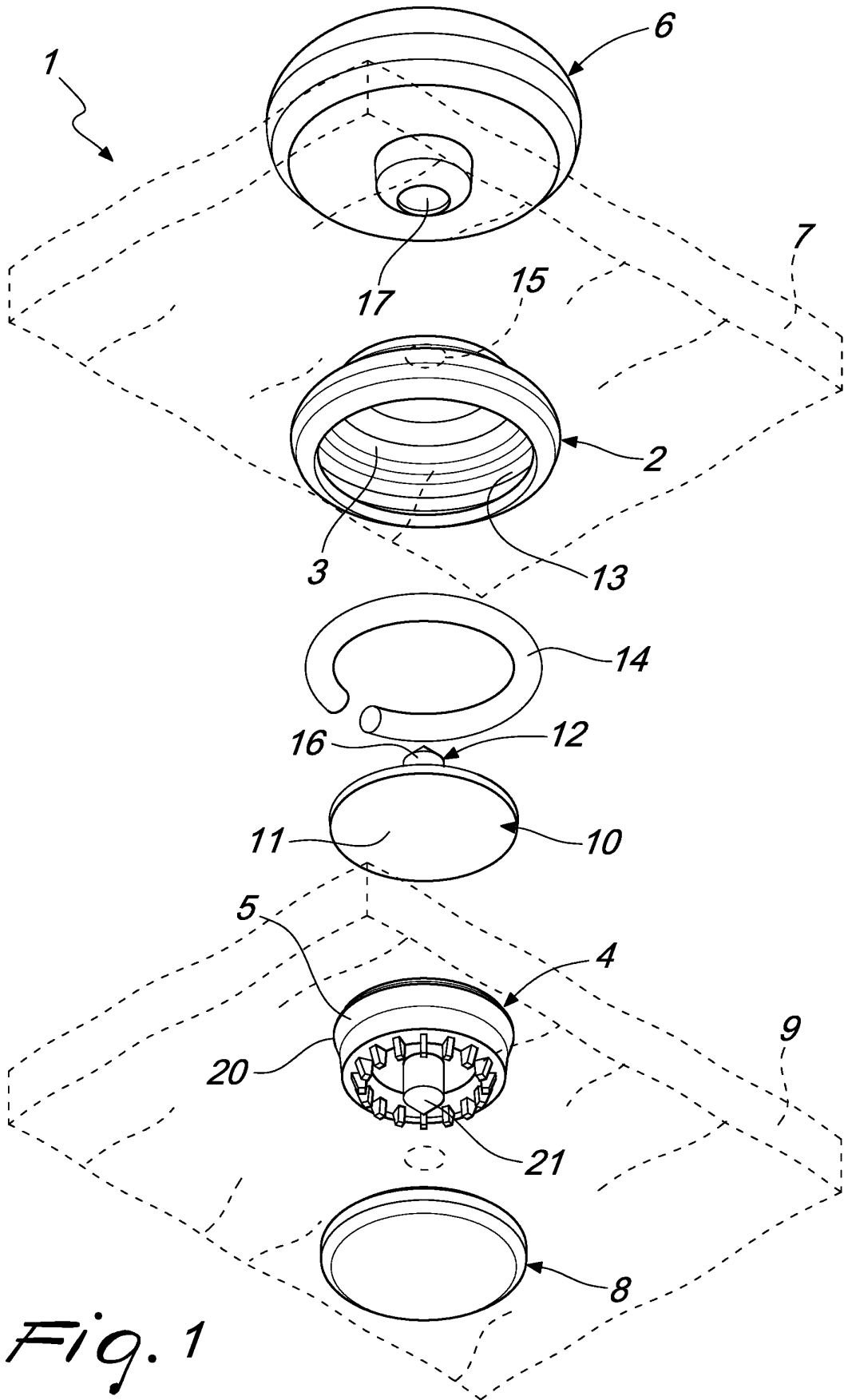

Fig. 1

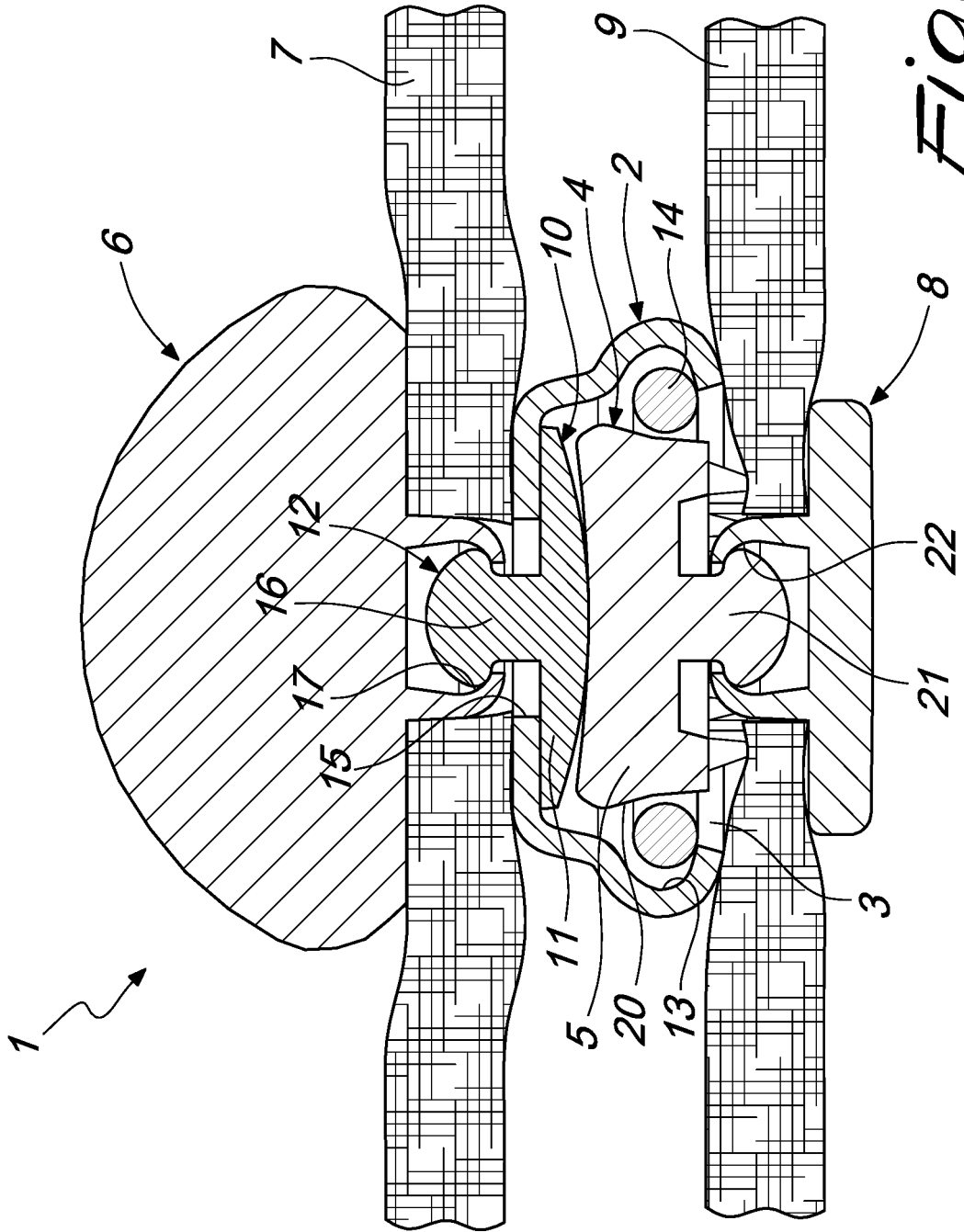

Fig. 3

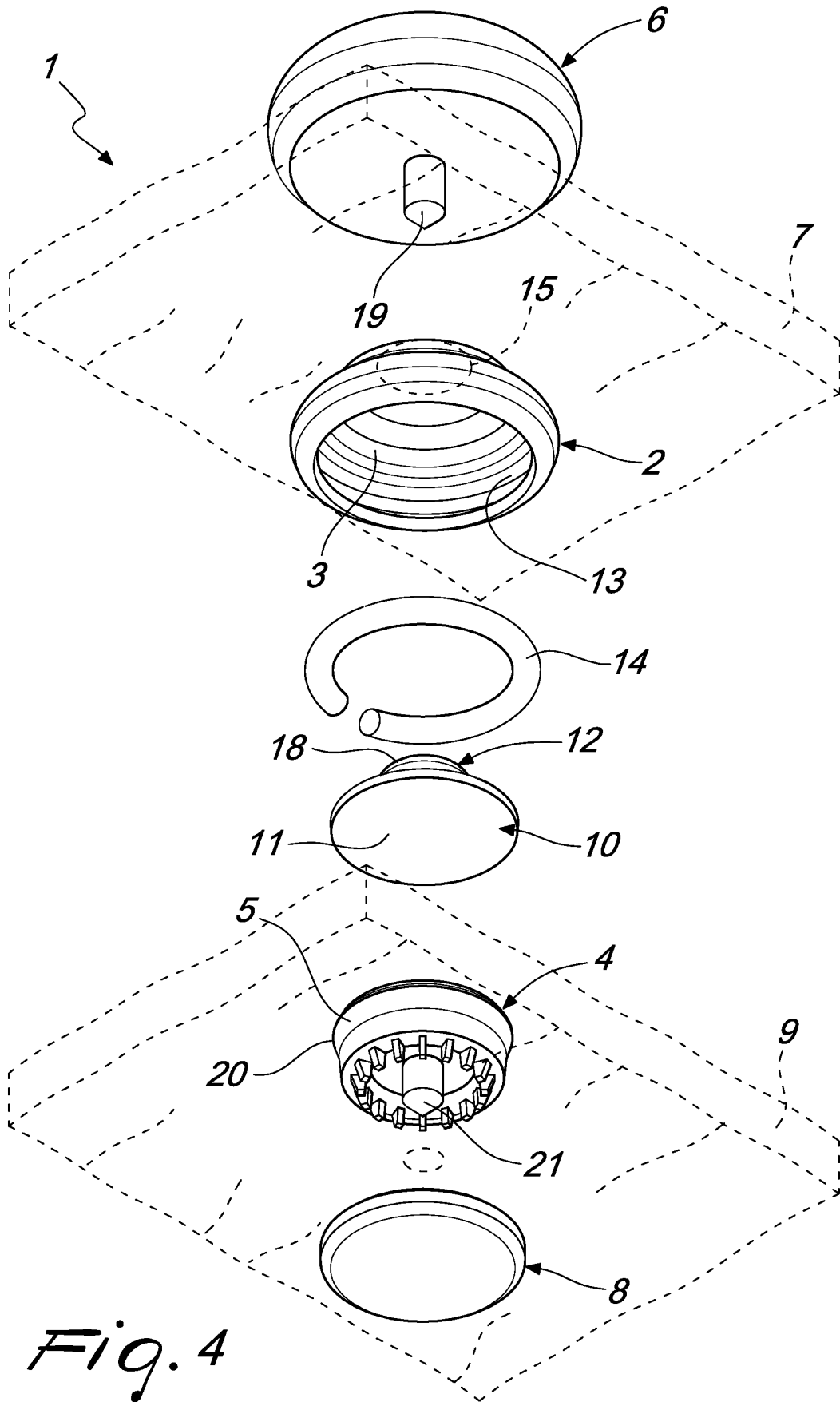

Fig. 4

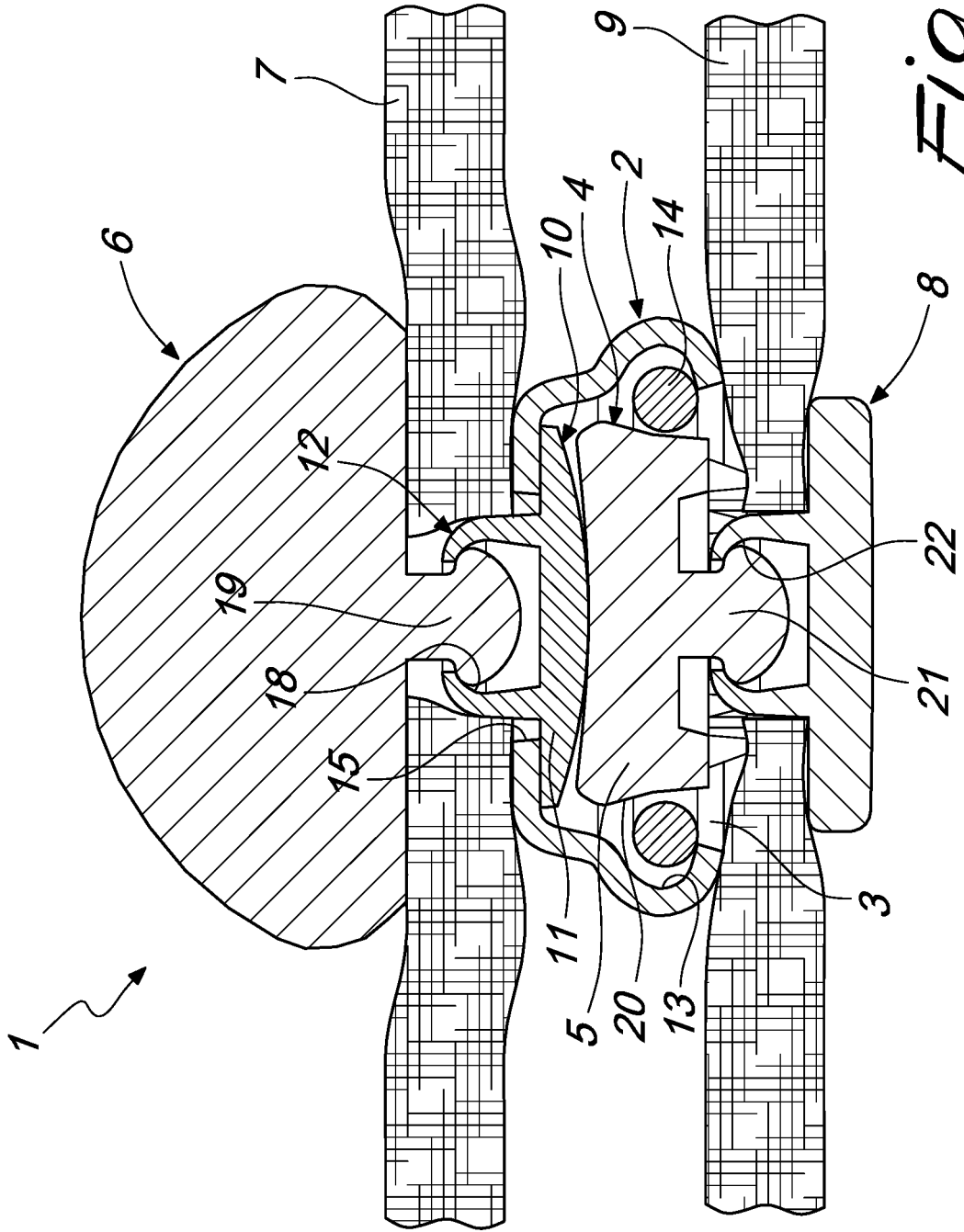

Fig. 6

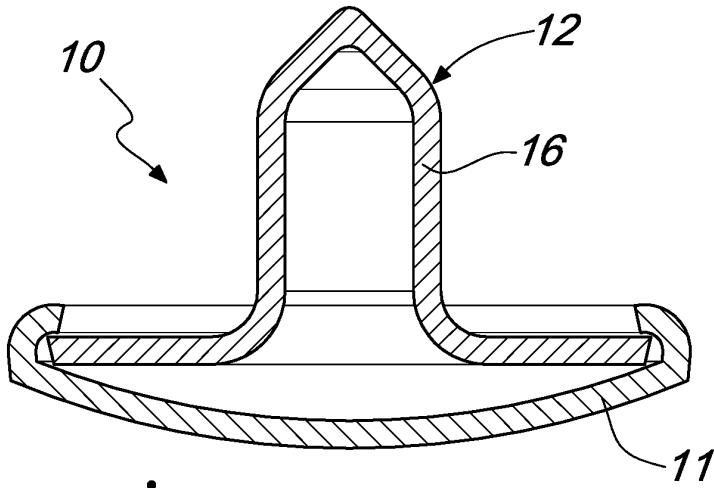

Fig. 7

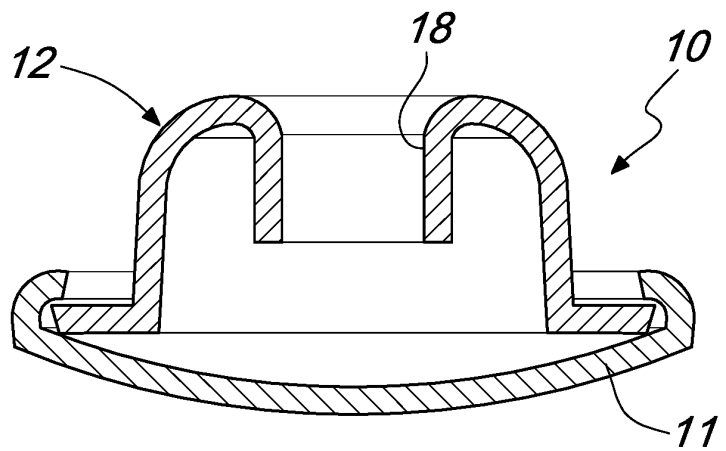

Fig. 8

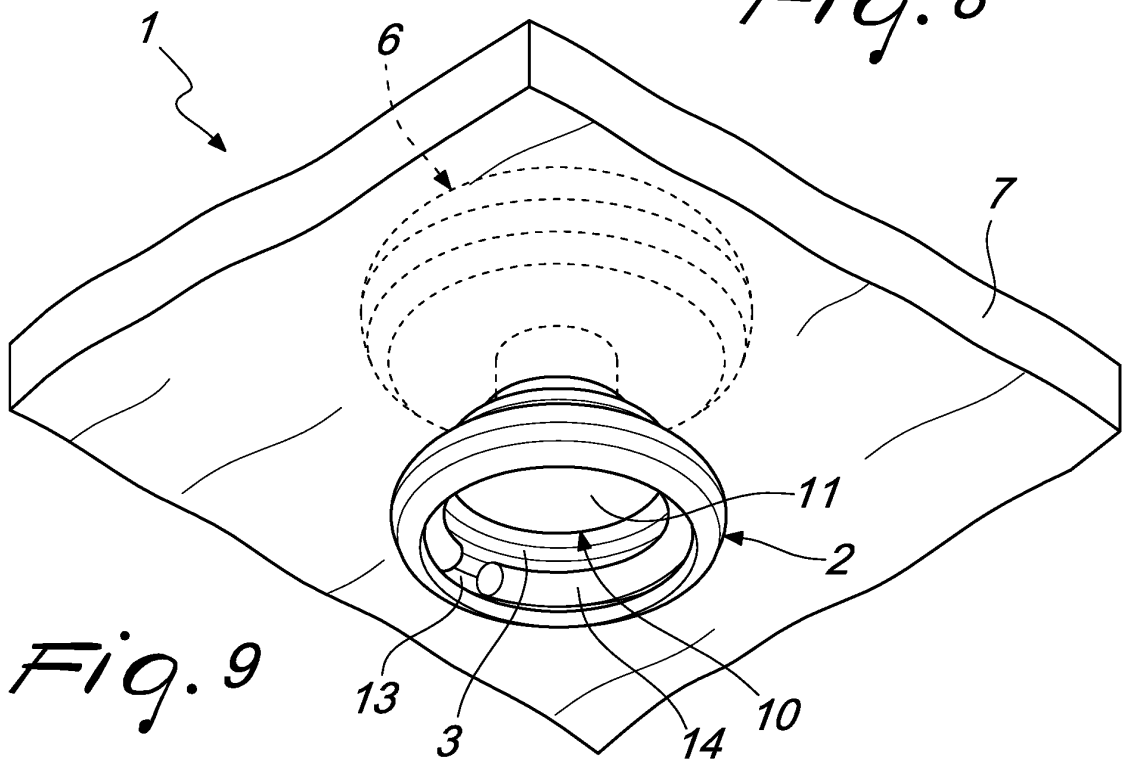

Fig. 9

REFERENCES CITED IN THE DESCRIPTION

This list of references cited by the applicant is for the reader's convenience only. It does not form part of the European patent document. Even though great care has been taken in compiling the references, errors or omissions cannot be excluded and the EPO disclaims all liability in this regard.

Patent documents cited in the description

- FR 995414 [0009]