



(12) **EUROPEAN PATENT APPLICATION**
published in accordance with Art. 153(4) EPC

(43) Date of publication:
31.01.2018 Bulletin 2018/05

(21) Application number: **16767930.7**

(22) Date of filing: **19.02.2016**

(51) Int Cl.:
C23C 2/02 (2006.01) C21D 1/76 (2006.01)
C21D 9/46 (2006.01) C21D 9/56 (2006.01)
C23C 2/28 (2006.01) C23C 2/40 (2006.01)
C22C 18/04 (2006.01) C22C 38/00 (2006.01)
C22C 38/14 (2006.01)

(86) International application number:
PCT/JP2016/000899

(87) International publication number:
WO 2016/152018 (29.09.2016 Gazette 2016/39)

(84) Designated Contracting States:
AL AT BE BG CH CY CZ DE DK EE ES FI FR GB GR HR HU IE IS IT LI LT LU LV MC MK MT NL NO PL PT RO RS SE SI SK SM TR
Designated Extension States:
BA ME
Designated Validation States:
MA MD

(30) Priority: **23.03.2015 JP 2015060139**

(71) Applicant: **JFE Steel Corporation**
Tokyo, 100-0011 (JP)

(72) Inventors:
• **TAKEDA, Gentaro**
Tokyo 100-0011 (JP)
• **MIYAKE, Masaru**
Tokyo 100-0011 (JP)

(74) Representative: **Grünecker Patent- und Rechtsanwälte**
PartG mbB
Leopoldstraße 4
80802 München (DE)

(54) **CONTINUOUS HOT-DIP GALVANIZATION APPARATUS AND HOT-DIP GALVANIZED STEEL SHEET MANUFACTURING METHOD**

(57) Provided is a continuous hot-dip galvanizing apparatus that can inhibit roll pick-up in a soaking zone caused by condensation or the like in a humidified gas pipe, and with which favorable coating appearance can be obtained. The continuous hot-dip galvanizing apparatus includes an annealing furnace in which a heating zone, a soaking zone, and a cooling zone are arranged in this order, and a hot-dip galvanizing line adjacent to the cooling zone. Gases supplied to the soaking zone (12) are: mixed gas obtained by mixing gas that is humidified by a humidifying device (50) and gas that is not humidified by the humidifying device; and dry gas that is not humidified by the humidifying device. The continuous hot-dip galvanizing apparatus includes a draining device (80) for draining circulating water from the humidifying device (50) when the mixed gas is not supplied to the soaking zone (12).

FIG. 2

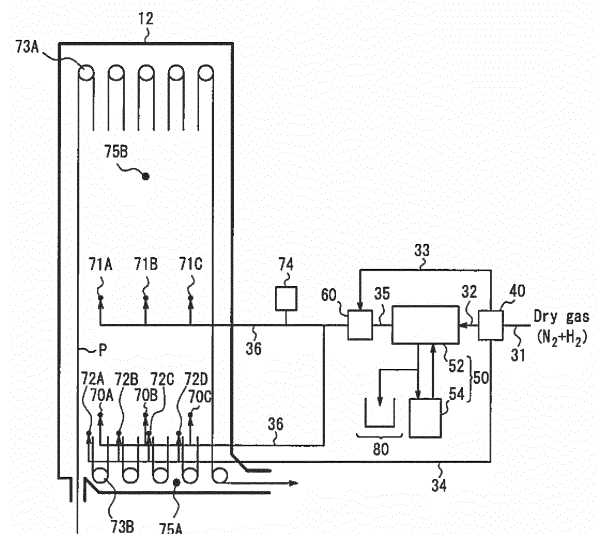

Description

TECHNICAL FIELD

5 **[0001]** This disclosure relates to a continuous hot-dip galvanizing apparatus including an annealing furnace in which a heating zone, a soaking zone, and a cooling zone are arranged in this order and a hot-dip galvanizing line adjacent to the cooling zone, and to a method of producing a hot-dip galvanized steel sheet using this continuous hot-dip galvanizing apparatus.

10 BACKGROUND

[0002] In recent years, the demand for high tensile strength steel sheets (high tensile steel sheets) which contribute to lighter-weight structures and the like is increasing in the fields of automobiles, household appliances, building products, and so forth. As high tensile strength steel materials, for example, it is known that a steel sheet with favorable hole expansion formability can be produced through inclusion of Si in steel, and a steel sheet with favorable ductility where retained austenite (γ) forms easily can be produced through inclusion of Si or Al in steel.

15 **[0003]** However, in the case of producing a galvanized steel sheet using, as a base material, a high tensile strength steel sheet containing a large amount of Si (particularly, 0.2 mass% or more), the following problem arises. The galvanized steel sheet is produced by, after heat-annealing the base material steel sheet at a temperature of about 600 °C to 900 °C in a reducing atmosphere or a non-oxidizing atmosphere, hot-dip galvanizing the steel sheet and further heat-alloying the galvanized coating.

[0004] Si in the steel is an oxidizable element, and is thus selectively oxidized in a typically used reducing atmosphere or non-oxidizing atmosphere, and concentrated at the surface of the steel sheet in the form of an oxide. This oxide decreases wettability with molten zinc in the galvanizing process, and causes non-coating. With an increase of the Si concentration in the steel, wettability decreases rapidly and non-coating occurs frequently. Even in the case where non-coating does not occur, there is still a problem of poor coating adhesion. Moreover, if Si in the steel is selectively oxidized and concentrated at the surface of the steel sheet, a significant alloying delay arises in the alloying process after the hot-dip galvanizing, leading to considerably lower productivity.

25 **[0005]** WO2007/043273 A1 (PTL 1) describes the following technique in relation to the problems set forth above. In a continuous annealing and hot-dip coating method that uses an annealing furnace having an upstream heating zone, a downstream heating zone, a soaking zone, and a cooling zone arranged in this order and a hot-dip molten bath, Si is internally oxidized and concentration of Si at the surface of the steel sheet is prevented by performing annealing under conditions including: heating or soaking the steel sheet at a steel sheet temperature in a range of 300 °C or higher by indirect heating; setting the atmosphere inside the furnace in each zone to an atmosphere of 1 vol% to 10 vol% hydrogen with the balance being nitrogen and incidental impurities; setting the steel sheet end-point temperature during heating in the upstream heating zone to 550 °C or higher and 750 °C or lower and the dew point in the upstream heating zone to lower than -25 °C; setting the dew point in the subsequent downstream heating zone and soaking zone to -30 °C or higher and 0 °C or lower; and setting the dew point in the cooling zone to lower than -25 °C. PTL 1 also describes humidifying mixed gas of nitrogen and hydrogen and introducing the mixed gas into the downstream heating zone and/or the soaking zone.

CITATION LIST

Patent Literature

45 **[0006]** PTL 1: WO2007/043273 A1

SUMMARY

50 (Technical Problem)

[0007] In production of a high tensile strength steel sheet, humidified gas is supplied to the soaking zone in addition to reducing or non-oxidizing dry gas, as described in PTL 1, in order to raise the dew point in the soaking zone. In contrast, in production of a normal strength steel sheet (hereinafter, referred to as a "normal steel sheet"), only reducing or non-oxidizing dry gas is supplied to the soaking zone and humidified gas is not supplied. Therefore, in a situation such as when a high tensile strength steel sheet and a normal steel sheet are to be produced consecutively, it is necessary to switch between use and non-use of humidified gas during operation.

[0008] We recognized that the problem set forth below occurs when switching between use and non-use of humidified

gas during operation. Specifically, we realized that if gas in a humidifying system is simply stopped during non-use of humidified gas, water from a humidifying device may spread and condense, and excessively humidified gas may accumulate in pipes of the humidifying system. Consequently, condensation or excessively humidified gas in the pipes may be sprayed into the soaking zone upon switching from non-use of the humidifying system to use of the humidifying system, and this may cause problems such as damage to a hearth roll and pick-up in the soaking zone, and formation of a water drop pattern on the steel sheet. Moreover, this may cause non-coating to occur in subsequent hot-dip galvanizing and may lead to poorer coating appearance.

[0009] In light of the problems set forth above, it would be helpful to provide a continuous hot-dip galvanizing apparatus and a method of producing a hot-dip galvanized steel sheet that can inhibit roll pick-up in a soaking zone caused by condensation or the like in a humidified gas pipe and with which favorable coating appearance can be obtained.

(Solution to Problem)

[0010] In order to solve the problems set forth above, we conducted detailed studies in relation to means for preventing the formation of condensation and the accumulation of excessively humidified gas in humidified gas pipes during non-use of humidified gas (i.e., while supply of humidified gas to a soaking zone is stopped). We discovered that the above objective can be achieved through the following configurations, and thus completed the disclosed techniques.

[0011] Specifically, primary features of the present disclosure are as follows.

(1) A continuous hot-dip galvanizing apparatus comprising:

an annealing furnace in which a heating zone, a soaking zone, and a cooling zone are arranged in this order;
 a hot-dip galvanizing line adjacent to the cooling zone;
 a first pipe through which a reducing or non-oxidizing dry gas passes;
 a gas distribution device that is connected to the first pipe and that distributes dry gas that has passed through the first pipe;
 a second pipe, a third pipe, and a fourth pipe that branch from the gas distribution device and through which dry gas that has been distributed by the gas distribution device passes;
 a humidifying device that is connected to the second pipe and into which dry gas that has passed through the second pipe is introduced;
 a fifth pipe that extends from the humidifying device and through which humidified gas that has been humidified by the humidifying device passes;
 a gas mixing device that is connected to the third pipe and the fifth pipe and that prepares mixed gas by mixing dry gas that has passed through the third pipe and humidified gas that has passed through the fifth pipe;
 a sixth pipe that extends from the gas mixing device and through which the mixed gas passes;
 a mixed gas supply port disposed in the soaking zone for supplying mixed gas that has passed through the sixth pipe into the soaking zone; and
 a dry gas supply port disposed in the soaking zone for supplying dry gas that has passed through the fourth pipe into the soaking zone, wherein
 the humidifying device includes a module including a vapor permeable membrane, and is configured to humidify the dry gas that has passed through the second pipe by, while the dry gas passes through one space in the module that is separated by the vapor permeable membrane, circulating water through another space in the module using a circulating constant-temperature water bath, and
 the continuous hot-dip galvanizing apparatus further comprises a draining device for draining water from the other space in the module when the mixed gas is not supplied to the soaking zone.

(2) The continuous hot-dip galvanizing apparatus according to the foregoing (1), further comprising an alloying line adjacent to the hot-dip galvanizing line.

(3) A method of producing a hot-dip galvanized steel sheet using the continuous hot-dip galvanizing apparatus according to the foregoing (1), comprising:

annealing a steel strip by conveying the steel strip through the heating zone, the soaking zone, and the cooling zone inside of the annealing furnace, in this order; and
 applying a hot-dip galvanized coating onto the steel strip exiting from the cooling zone using the hot-dip galvanizing line, wherein
 in a first operational state in which the mixed gas and the dry gas are supplied to the soaking zone, water circulation is performed using the circulating constant-temperature water bath, and
 in a second operational state in which only the dry gas is supplied to the soaking zone and the mixed gas is not

supplied, distribution of the dry gas to the second pipe is stopped, water is drained from the other space in the module using the draining device, and water circulation with the circulating constant-temperature water tank is not performed.

(4) The method of producing a hot-dip galvanized steel sheet according to the foregoing (3), wherein when switching from the second operational state to the first operational state, water circulation using the circulating constant-temperature water bath is restarted and subsequently distribution of the dry gas to the second pipe is restarted.

(5) The method of producing a hot-dip galvanized steel sheet according to the foregoing (3) or (4), wherein a dew point in the soaking zone is controlled to $-20\text{ }^{\circ}\text{C}$ or higher and $0\text{ }^{\circ}\text{C}$ or lower in the first operational state.

(6) The method of producing a hot-dip galvanized steel sheet according to any one of the foregoing (3) to (5), further comprising heat-alloying the galvanized coating applied onto the steel strip using the alloying line according to the foregoing (2).

(Advantageous Effect)

[0012] Through the disclosed continuous hot-dip galvanizing apparatus and method of producing a hot-dip galvanized steel sheet, it is possible to inhibit roll pick-up in a soaking zone caused by condensation or the like in a humidified gas pipe and obtain favorable coating appearance.

BRIEF DESCRIPTION OF THE DRAWINGS

[0013] In the accompanying drawings:

FIG. 1 is a schematic view illustrating configuration of a continuous hot-dip galvanizing apparatus 100 according to one disclosed embodiment;

FIG. 2 is a schematic view illustrating a supply system for supplying mixed gas and dry gas to a soaking zone 12 in FIG. 1; and

FIG. 3 is an enlarged schematic view illustrating a humidifying device 50 and a draining device 80 in FIG. 2.

DETAILED DESCRIPTION

[0014] Configuration of a continuous hot-dip galvanizing apparatus 100 according to one disclosed embodiment is described with reference to FIG. 1. The continuous hot-dip galvanizing apparatus 100 includes an annealing furnace 20 in which a heating zone 10, a soaking zone 12, and cooling zones 14 and 16 are arranged in this order, a hot-dip galvanizing bath 22 adjacent to the cooling zone 16 that serves as a hot-dip galvanizing line, and an alloying line 24 adjacent to the hot-dip galvanizing bath 22. The heating zone 10 in this embodiment includes a first heating zone 10A (upstream heating zone) and a second heating zone 10B (downstream heating zone). The cooling zone includes a first cooling zone 14 (rapid cooling zone) and a second cooling zone 16 (slow cooling zone). A snout 18 connected to the second cooling zone 16 has its tip immersed in the hot-dip galvanizing bath 22, thus connecting the annealing furnace 20 and the hot-dip galvanizing bath 22. Another disclosed embodiment is a method of producing a hot-dip galvanized steel sheet using the continuous hot-dip galvanizing apparatus 100.

[0015] A steel strip P is introduced into the first heating zone 10A from a steel strip introduction port in a lower part of the first heating zone 10A. One or more hearth rolls are arranged in upper and lower parts of each of the zones 10, 12, 14, and 16. In the case where the steel strip P is folded back by 180 degrees at one or more hearth rolls, the steel strip P is conveyed vertically a plurality of times inside a corresponding zone of the annealing furnace 20, forming a plurality of passes. While FIG. 1 illustrates an example of having 10 passes in the soaking zone 12, 2 passes in the first cooling zone 14, and 2 passes in the second cooling zone 16, the numbers of passes are not limited to those in this example, and may be set as appropriate depending on the processing conditions. At some hearth rolls, the steel strip P is not folded back but changed in direction at a right angle to move to the next zone. The steel strip P is thus annealed in the annealing furnace 20 by being conveyed through the heating zone 10, the soaking zone 12, and the cooling zones 14 and 16 in this order.

[0016] Adjacent zones in the annealing furnace 20 communicate through a communication portion connecting the upper parts or lower parts of the respective zones. In this embodiment, the first heating zone 10A and the second heating zone 10B communicate through a throat (restriction portion) connecting the upper parts of the respective zones. The second heating zone 10B and the soaking zone 12 communicate through a throat connecting the lower parts of the respective zones. The soaking zone 12 and the first cooling zone 14 communicate through a throat connecting the lower parts of the respective zones. The first cooling zone 14 and the second cooling zone 16 communicate through a throat

connecting the lower parts of the respective zones. Although the height of each throat may be set as appropriate, it is preferable that the height of each throat is as low as possible to enhance the independence of the atmosphere in each zone. Gas in the annealing furnace 20 flows from downstream to upstream and is discharged from the steel strip introduction port in the lower part of the first heating zone 10A.

5

(Heating zone)

[0017] In this embodiment, the second heating zone 10B is a direct fired furnace (DFF). The DFF may be a commonly known DFF. Burners are distributed in the inner wall of the direct fired furnace in the second heating zone 10B so as to face the steel strip P (note that these burners are not illustrated in FIG. 1). It is preferable that the burners are divided into groups, and that the combustion rate and the air ratio in each group are independently controllable. Combustion exhaust gas in the second heating zone 10B is supplied into the first heating zone 10A, and the steel strip P is preheated by the heat of the gas.

10

[0018] The combustion rate is a value obtained by dividing the amount of fuel gas actually introduced into a burner by the amount of fuel gas of the burner under its maximum combustion load. The combustion rate at the time of combustion by the burner under its maximum combustion load is 100 %. When the combustion load is low, the burner cannot maintain a stable combustion state. Accordingly, the combustion rate is preferably adjusted to 30 % or more.

15

[0019] The air ratio is a value obtained by dividing the amount of air actually introduced into a burner by the amount of air necessary for complete combustion of fuel gas. In this embodiment, the heating burners in the second heating zone 10B are divided into four groups (#1 to #4), and the three groups (#1 to #3) upstream in the steel sheet traveling direction are made up of oxidizing burners, and the last group (#4) is made up of reducing burners. The air ratio of the oxidizing burners and the air ratio of the reducing burners are independently controllable. The air ratio of the oxidizing burners is preferably adjusted to 0.95 or more and 1.5 or less. The air ratio of the reducing burners is preferably adjusted to 0.5 or more and less than 0.95. The temperature in the second heating zone 10B is preferably adjusted to 800 °C to 1200 °C.

20

25

(Soaking zone)

[0020] In this embodiment, the soaking zone 12 is capable of indirectly heating the steel strip P using a radiant tube (RT) (not illustrated) as heating means. The average temperature T_r (°C) in the soaking zone 12 is measured by inserting a thermocouple into the soaking zone 12 and is preferably adjusted to 700 °C to 900 °C.

30

[0021] Reducing gas or non-oxidizing gas is supplied to the soaking zone 12. H_2/N_2 mixed gas is typically used as the reducing gas. An example is gas (dew point: about -60 °C) having a composition containing 1 vol% to 20 vol% H_2 with the balance being N_2 and incidental impurities. An example of the non-oxidizing gas is gas (dew point: about -60 °C) having a composition containing N_2 and incidental impurities.

35

[0022] In this embodiment, the reducing gas or non-oxidizing gas supplied to the soaking zone 12 is in two forms: mixed gas and dry gas. Herein, "dry gas" refers to reducing gas or non-oxidizing gas that has a dew point of about -60 °C to -50 °C and that is not humidified by a humidifying device. On the other hand, "mixed gas" refers to gas obtained through mixing of gas that is humidified by the humidifying device and gas that is not humidified by the humidifying device in a specific mixing ratio such as to have a dew point of -20 °C to 10 °C.

40

[0023] A supply system for supplying mixed gas and dry gas to the soaking zone 12 is described with reference to FIG. 2. The supply system includes, from upstream, a first pipe 31, a second pipe 32, a third pipe 33, a fourth pipe 34, a fifth pipe 35, and a sixth pipe 36, and also includes a gas distribution device 40, a humidifying device 50, a gas mixing device 60, and a draining device 80.

45

[0024] Dry gas that is supplied from a gas supply source (not illustrated) passes through the first pipe 31.

[0025] The gas distribution device 40 is connected to the first pipe 31 and distributes dry gas that has passed through the first pipe 31 in a freely variable ratio to the following three systems: the second pipe 32, the third pipe 33, and the fourth pipe 34. The second pipe 32, the third pipe 33, and the fourth pipe 34 branch from the gas distribution device 40 and dry gas that has been distributed by the gas distribution device 40 passes therethrough. Specifically, one portion of dry gas that has passed through the first pipe 31 is supplied to the humidifying device 50 through the second pipe 32, another portion of this dry gas is supplied to the gas mixing device 60 through the third pipe 33, and the remaining portion of this dry gas is supplied straight to the soaking zone 12 through the fourth pipe 34. The gas distribution device 40 cuts off distribution to the second pipe 32 and the third pipe 33 during non-use of mixed gas described further below.

50

[0026] First, supply of dry gas is described. Dry gas that has passed through the fourth pipe 34 is supplied into the soaking zone 12 via dry gas supply ports 72A, 72B, 72C, and 72D that are disposed in the soaking zone 12. The position and number of dry gas supply ports is not specifically limited and may be set as appropriate in consideration of various conditions. However, it is preferable that a plurality of dry gas supply ports is arranged at the same height position and that dry gas supply ports are arranged uniformly in the steel strip traveling direction.

55

[0027] Next, supply of mixed gas is described. The humidifying device 50 is connected to the second pipe 32 and dry gas that has passed through the second pipe 32 is introduced therein. The fifth pipe 35 extends from the humidifying device 50 and humidified gas that has been humidified by the humidifying device 50 passes therethrough.

5 [0028] The gas mixing device 60 is connected to the third pipe 33 and the fifth pipe 35, and prepares mixed gas having a desired dew point by mixing dry gas that has passed through the third pipe and humidified gas that has passed through the fifth pipe in a given ratio that can be varied. The sixth pipe 36 is a mixed gas pipe that extends from the gas mixing device 60, and mixed gas discharged from the gas mixing device 60 passes therethrough. Mixed gas that has passed through the sixth pipe 36 is supplied into the soaking zone 12 via one or more mixed gas supply ports that are disposed in the soaking zone 12. In this embodiment, mixed gas is supplied by two systems: a system of mixed gas supply ports 70A, 70B, and 70C and a system of mixed gas supply ports 71A, 71B, and 71C. The position and number of mixed gas supply ports is not specifically limited and may be set as appropriate in consideration of various conditions. It is preferable that, as in this embodiment, a plurality of mixed gas supply ports is arranged at each of two or more different height positions and that mixed gas supply ports are arranged uniformly in the steel strip traveling direction. The dew point of the mixed gas can be measured by a mixed gas dew point meter 74 disposed in the sixth pipe.

10 [0029] Next, configurations of the humidifying device 50 and the draining device 80, which is a disclosed feature, are described with reference to FIG. 3. The humidifying device 50 includes a tube-shaped module 52 and a circulating constant-temperature water bath 54. Vapor permeable membranes 51 are disposed in the module 52. The vapor permeable membranes 51 in this embodiment are fluorine or polyimide hollow fiber membranes. Although only two vapor permeable membranes 51 are illustrated in FIG. 3, about 50 to 500 membranes are arranged substantially in parallel. In the module 52, the dry gas that has passed through the second pipe 32 flows through the inside 53A of the vapor permeable membranes, whereas pure water adjusted to a specific temperature in the circulating constant-temperature water bath 54 circulates at the outside 53B of the vapor permeable membranes. Specifically, the outside 53B of the vapor permeable membranes in the module is in communication with the circulating constant-temperature water bath 54 via passages 55A and 55B.

15 [0030] The fluorine or polyimide hollow fiber membranes are each a type of ion exchange membrane with affinity for water molecules. When moisture concentration differs between the inside and outside of the hollow fiber membrane, a force for equalizing the moisture concentration difference arises and, with this force as a driving force, moisture permeates through the membrane to move to the side with lower moisture concentration. Accordingly, dry gas is humidified to obtain humidified gas when the dry gas passes through the inside 53A of the vapor permeable membranes in the module 52. The temperature of dry gas varies with seasonal or daily air temperature change. In this embodiment, however, heat exchange is possible by ensuring a sufficient contact area between gas and water through the vapor permeable membranes 51. Accordingly, regardless of whether the dry gas temperature is higher or lower than the circulating water temperature, the dry gas is humidified to the same dew point as the set water temperature, thus achieving highly accurate dew point control. The dew point of the humidified gas can be controlled to any value in the range of 5 °C to 50 °C. When the dew point of the humidified gas is higher than the temperature of a pipe, there is a possibility that condensation occurs in the pipe and that condensation enters directly into the furnace. A humidified gas pipe is, therefore, heated/heat-retained to at least the dew point of the humidified gas and at least the external air temperature.

20 [0031] Note that the internal configuration of the module 52 is not limited to the configuration illustrated in FIG. 3. For example, the vapor permeable membranes may alternatively be fluorine or polyimide flat membranes. In such a configuration, the dry gas that has passed through the second pipe 32 is humidified by, while the dry gas passes through one space in the module that is separated by the vapor permeable membranes, circulating water through another space in the module using the circulating constant-temperature water bath 54.

25 [0032] A feature of the continuous hot-dip galvanizing apparatus 100 in this embodiment is that the continuous hot-dip galvanizing apparatus 100 includes the draining device 80 for draining water from the space at the outside 53B of the vapor permeable membranes in the module when mixed gas is not supplied to the soaking zone. FIG. 3 illustrates an example of the draining device 80. The draining device 80 includes a first isolation valve 82, a second passage 84, a second isolation valve 86, and a drainage tank 88. The first isolation valve 82 is disposed in the passage 55B through which water passes when moving toward the circulating constant-temperature water bath 54 from the outside 53B of the vapor permeable membranes in the module. The second passage 84 branches from the passage 55B at a section that is further upstream than the first isolation valve 82 (i.e., toward the outside 53B of the vapor permeable membranes). A tip of the second passage 84 is positioned above the drainage tank 88. The second isolation valve 86 is disposed in the second passage 84. The drainage tank 88 holds water that is drained from the second passage 84.

30 [0033] While humidified gas is being produced, the first isolation valve 82 is fully opened, the second isolation valve 86 is fully closed, and the circulating constant-temperature water bath 54 is used to circulate water at the outside 53B of the vapor permeable membranes in the module. While humidified gas is not being produced, water circulation is stopped, the second isolation valve 86 is fully opened, and the first isolation valve 82 is fully closed to drain water toward the drainage tank 88 from the space at the outside 53B of the vapor permeable membranes in the module. In a situation in which it is not possible to position the module 52 at least 200 mm higher than the top of the drainage tank 88, it is

preferable that a suction device or the like is disposed at the drainage tank side in order to drain water in the humidifying device.

5 **[0034]** In production of a high tensile strength steel sheet, for example, mixed gas containing humidified gas is supplied to the soaking zone 12 in addition to dry gas. Herein, this state is referred to as a "first operational state". In contrast, in production of a normal steel sheet, for example, only dry gas is supplied to the soaking zone 12, and mixed gas is not supplied. Herein, this state is referred to as a "second operational state".

10 **[0035]** When humidified gas is not required in the second operational state, distribution of dry gas to the second pipe 32 and the humidifying device 50 can be stopped so that dry gas does not flow through the inside 53A of the vapor permeable membranes in the module. However, if water circulation using the circulating constant-temperature water bath 54 is allowed to continue over a long period, condensation occurs in pipes upstream and downstream of the module 52 (i.e., in the second pipe 32 and the fifth pipe 35), and further downstream in the sixth pipe 36. Even supposing that these pipes are heated/heat-retained, excessively humidified gas accumulates in the pipes since the inside of the pipes is in a constantly saturated state with moisture. Moreover, even supposing that water circulation is stopped, the same problems may arise if the space at the outside 53B of the vapor permeable membranes in the module is left in a water-filled state for a long period.

15 **[0036]** Therefore, switching between the first operational state and the second operational state in this embodiment is performed as follows. In the first operational state, water is circulated using the circulating constant-temperature water bath 54 and humidified gas is produced in a state in which the first isolation valve 82 is fully opened and the second isolation valve 86 is fully closed. In the second operational state, distribution of dry gas to the second pipe 32 is stopped and water circulation using the circulating constant-temperature water bath 54 is stopped, and subsequently water is drained from the space at the outside 53B of the vapor permeable membranes in the module using the draining device 80. Specifically, the second isolation valve 86 is fully opened and the first isolation valve 82 is fully closed. In other words, in the second operational state, a state in which water is not present in the space at the outside 53B of the vapor permeable membranes is obtained and water is not circulated using the circulating constant-temperature water bath 54.

20 **[0037]** Switching in this manner can prevent condensation and accumulation of excessively humidified gas in pipes upstream and downstream of the module 52 (i.e., the second pipe 32 and the fifth pipe 35), and further downstream in the sixth pipe 36, while in the second operational state. Accordingly, condensation and excessively humidified gas do not enter the soaking zone 12 upon switching from the second operational state to the first operational state. This can inhibit the occurrence of roll pick-up in the soaking zone 12 and, as a result, enables favorable coating appearance to be obtained.

25 **[0038]** When switching from the second operational state to the first operational state (for example, when switching from production of a normal steel sheet to production of a high tensile strength steel sheet), water circulation using the circulating constant-temperature water bath 54 is restarted and subsequently distribution of dry gas to the second pipe 32 is restarted.

30 **[0039]** The gas flow rate Q_{rd} of dry gas supplied to the soaking zone 12 via the fourth pipe 34 in the first operational state and the second operational state is measured by a gas flowmeter (not illustrated) disposed in the fourth pipe 34. Although no specific limitations are placed on the gas flow rate Q_{rd} , the gas flow rate Q_{rd} is about 0 Nm^3/hr to 600 Nm^3/hr . This maintains the furnace pressure in the soaking zone 12 at an appropriate pressure (higher than the direct fired zone) but without the furnace pressure becoming excessively high.

35 **[0040]** The gas flow rate Q_{rw} of mixed gas supplied to the soaking zone 12 via the sixth pipe 36 in the first operational state is measured by a gas flowmeter (not illustrated) disposed in the sixth pipe 36. Although no specific limitations are placed on the gas flow rate Q_{rw} the gas flow rate Q_{rw} is about 100 Nm^3/hr to 500 Nm^3/hr . This maintains the furnace pressure in the soaking zone 12 at an appropriate pressure (higher than the direct fired zone) but without the furnace pressure becoming excessively high.

40 **[0041]** It is preferable that the dew point in the soaking zone 12 is constantly controlled to $-20\text{ }^\circ\text{C}$ or higher and $0\text{ }^\circ\text{C}$ or lower in the first operational state. Dew point meters are installed at at least one location (dew point measurement position 75A) near lower part hearth rolls 73B (lowest part of the soaking zone) and at least one location (dew point measurement position 75B) below upper part hearth rolls 73A at a higher position than half way up the soaking zone in a height direction (upper part of the soaking zone). Controlling the dew point in the soaking zone 12 to $-20\text{ }^\circ\text{C}$ or higher enables an appropriate alloying temperature in subsequent alloying treatment and enables desired mechanical properties to be obtained. On the other hand, since the steel substrate of the steel strip starts oxidizing when the dew point in the soaking zone 12 is $+10\text{ }^\circ\text{C}$ or higher, the upper limit of the dew point is preferably $0\text{ }^\circ\text{C}$ in terms of uniformity of the dew point distribution in the soaking zone 12 and minimization of the dew point variation range.

45 **[0042]** Mixed gas having a freely selected dew point can be supplied into the soaking zone 12 by adjusting the mixing proportions of gases in the gas mixing device 30. Mixed gas having a high dew point may be supplied to the soaking zone 12 if the dew point in the soaking zone 12 is about to fall below the target range. Conversely, mixed gas having a low dew point may be supplied to the soaking zone 12 if the dew point in the soaking zone 12 is about to rise above the

target range. In this manner, the dew point in the soaking zone 12 can be constantly controlled to $-20\text{ }^{\circ}\text{C}$ or higher and $0\text{ }^{\circ}\text{C}$ or lower in the first operational state.

(Cooling zone)

[0043] In this embodiment, the cooling zones 14 and 16 cool the steel strip P. The steel strip P is cooled to about $480\text{ }^{\circ}\text{C}$ to $530\text{ }^{\circ}\text{C}$ in the first cooling zone 14, and cooled to about $470\text{ }^{\circ}\text{C}$ to $500\text{ }^{\circ}\text{C}$ in the second cooling zone 16.

[0044] The cooling zones 14 and 16 are also supplied with the aforementioned reducing gas or non-oxidizing gas, but in the case of the cooling zones 14 and 16, only dry gas is supplied. Although no specific limitations are placed on supply of dry gas to the cooling zones 14 and 16, it is preferable that the dry gas is supplied from supply ports at at least two locations in a height direction and at least two locations in a longitudinal direction to enable uniform supply into the cooling zone. The total gas flow rate Qcd of dry gas supplied to the cooling zones 14 and 16 is measured by one or more gas flowmeters (not illustrated) disposed in pipes. Although no specific limitations are placed on the total gas flow rate Qcd, the total gas flow rate Qcd is about $200\text{ Nm}^3/\text{hr}$ to $1,000\text{ Nm}^3/\text{hr}$. This maintains the furnace pressure in the soaking zone 12 at an appropriate pressure (higher than the direct fired zone) but without the furnace pressure becoming excessively high.

(Hot-dip galvanizing bath)

[0045] The hot-dip galvanizing bath 22 can be used to apply a hot-dip galvanized coating onto the steel strip P exiting from the second cooling zone 16. The hot-dip galvanizing may be performed according to a usual method.

(Alloying line)

[0046] The alloying line 24 can be used to heat-alloy the galvanized coating applied onto the steel strip P. The alloying treatment may be performed according to a usual method. In this embodiment, the alloying temperature is kept from being high, thus preventing a decrease in tensile strength of the produced galvanized steel sheet. However, the alloying line 24 and the alloying treatment performed thereby are not essential to the disclosed techniques because the effects of inhibiting roll pick-up in the soaking zone caused by condensation or the like in a humidified gas pipe and obtaining favorable coating appearance can be achieved even when the alloying treatment is omitted.

EXAMPLES

(Experimental conditions)

[0047] The continuous hot-dip galvanizing apparatus illustrated in FIGS. 1 to 3 was used to anneal steel strips having chemical compositions shown in Table 1 under annealing conditions shown in Table 2, and then hot-dip galvanize and alloy the steel strips. Steel sample ID A is normal steel and steel sample ID B is high tensile strength steel. In the example and comparative example, annealing, hot-dip galvanizing, and alloying treatment were performed continuously with a sheet passing order shown in Table 2.

[0048] A DFF was used as the second heating zone. Heating burners were divided into four groups (#1 to #4) where the three groups (#1 to #3) upstream in the steel sheet traveling direction were made up of oxidizing burners and the last group (#4) was made up of reducing burners, and the air ratios of the oxidizing burners and reducing burners were set to the values shown in Table 2. The length of each group in the steel sheet conveyance direction was 4 m.

[0049] An RT furnace having a volume V_r of 700 m^3 was used as the soaking zone. The average temperature T_r in the soaking zone was set to the value shown in Table 2. Gas (dew point: $-50\text{ }^{\circ}\text{C}$) having a composition containing 15 vol% H_2 with the balance being N_2 and incidental impurities was used as dry gas. A portion of the dry gas was humidified by a humidifying device having 10 hollow fiber membrane-type humidifying modules to prepare mixed gas. In each of the modules, the maximum dry gas flow rate was 500 L/min and the maximum water circulation rate was 10 L/min. A circulating constant-temperature water bath capable of supplying a total of 100 L/min of pure water was used as a common water bath for each of the modules. Dry gas supply ports and mixed gas supply ports were arranged at the positions illustrated in FIG. 2. The draining device illustrated in FIG. 3 was also set-up.

[0050] In the example and comparative example, gas was supplied to the soaking zone by adopting the second operational state during passing of a sheet with steel sample ID A and adopting the first operational state during passing of a sheet with steel sample ID B. The dry gas flow rate Q_{rd} , mixed gas flow rate Q_{rw} , and mixed gas dew point shown in Table 2 are each a stable value during passing of a corresponding sheet.

[0051] In the comparative example, supply of dry gas to the second pipe was stopped during passing of a sheet with steel sample ID A in the second operational state, but water circulation using the circulating constant-temperature water

bath was continued. In contrast, during passing of a sheet with steel sample ID A in the second operational state in the example, distribution of dry gas to the second pipe was stopped and water circulation using the circulating constant-temperature water bath was stopped, and subsequently water was drained from space at the outside of vapor permeable membranes in the modules using the draining device.

5 **[0052]** The dry gas (dew point: -50 °C) was supplied to the first and second cooling zones at the lowest part of each of the zones with the flow rate shown in Table 2.

[0053] The temperature of the molten bath was set to 460 °C, the Al concentration in the molten bath was set to 0.130 %, and the coating weight was adjusted to 45 g/m² per surface by gas wiping. The line speed was set to 80 mpm to 100 mpm. After the hot-dip galvanizing, alloying treatment was performed in an induction heating-type alloying furnace so that the coating alloying degree (Fe content) was 10 % to 13 %. The alloying temperature in the treatment was as shown in Table 2.

(Evaluation method)

15 **[0054]** Evaluation of the coating appearance was conducted through inspection by an optical surface defect meter (detection of non-coating defects or overoxidation defects of φ0.5 or more) and visual determination of alloying unevenness. Samples passing all criteria were rated "excellent", samples having a low degree of alloying unevenness were rated "good", and samples failing at least one of the criteria were rated "poor". The results are shown in Table 2.

20 **[0055]** In addition, the tensile strength of a galvanized steel sheet produced under each set of conditions was measured. Normal steel with steel sample ID A was evaluated to pass when the tensile strength was 270 MPa or more, and high tensile strength steel with steel sample ID B was evaluated to pass when the tensile strength was 980 MPa or more. The results are shown in Table 2.

(Evaluation results)

25 **[0056]** In Comparative Example No. 1, mixed gas was supplied to raise the dew point of the soaking zone during passing of a sheet with steel sample ID B, and thus it was not necessary to excessively raise the alloying temperature and there was no problem in terms of tensile strength. However, moisture that had condensed in pipes was supplied into the soaking zone when supply of humidified gas was started for passing of the second sheet. This caused localized elevation of the dew point near the hearth rolls, leading to the occurrence of roll pick-up, and scratches due to this roll pick-up were formed in the steel strip surface. This resulted in poorer coating appearance for the second passed sheet through to the fourth passed sheet. In contrast, it was possible to perform switching of humidified gas without formation of condensation in pipes in Example No. 2. As a result, all the evaluation criteria were passed.

35 [Table 1]

[0057]

Table 1

	(Mass%)						
Steel sample ID	C	Si	Mn	P	S	Nb	Ti
A	0.001	0.01	0.15	0.01	0.005	0.005	0.03
B	0.11	1.5	2.7	0.01	0.001	0.001	0.001

[Table 2]

50 **[0058]**

Table 2

No.	Sheet passing order	Steel sample ID	Heating zone (DFF)			Soaking zone (RTF)								Cooling zone	Alloying treatment	Coating appearance	Tensile strength (MPa)	Classification
			Oxidizing burner air ratio	Reducing burner air ratio	Discharge side temperature (°C)	Upper part dew point (°C)	Lower part dew point (°C)	Average temperature Tr (°C)	Dry gas flow rate Q _{rd} (Nm ³ /hr)	Mixed gas flow rate Q _{rw} (Nm ³ /hr)	Mixed gas dew point (°C)	Water circulation in humidifying device	Gas flow rate Q _{cd} (Nm ³ /hr)					
1	1	A	0.95	0.85	680	-29.3	-39.8	800	452	0	-	Yes	480	500	Excellent	308	Comparative example	
	2	B	1.15	0.85	721	1.2	-9.2	830	280	170	5.0	Yes	472	508	Poor	1080		
	3	B	1.15	0.85	723	-11.1	-18.5	831	282	170	5.0	Yes	475	520	Poor	1030		
	4	A	0.95	0.85	680	-27.4	-34.3	800	455	0	-	Yes	462	501	Poor	310		
2	1	A	0.95	0.85	680	-32.5	-38.2	801	470	0	-	No	470	512	Excellent	305	Example	
	2	B	1.15	0.85	721	-12.3	-16.2	830	272	200	5.0	Yes	472	513	Excellent	1045		
	3	B	1.15	0.85	723	-13.5	-18.4	849	305	170	5.0	Yes	468	510	Excellent	1052		
	4	A	0.95	0.85	680	-27.2	-35.9	810	460	0	-	No	470	503	Excellent	301		
	5	B	1.15	0.85	725	-11.3	-16.1	852	241	250	5.0	Yes	467	509	Excellent	1030		
	6	A	0.95	0.85	680	-28.2	-36.5	811	465	0	-	No	480	500	Excellent	303		

55 INDUSTRIAL APPLICABILITY

[0059] Through the disclosed continuous hot-dip galvanizing apparatus and method of producing a hot-dip galvanized steel sheet, it is possible to inhibit roll pick-up in a soaking zone caused by condensation or the like in a humidified gas

pipe and obtain favorable coating appearance.

REFERENCE SIGNS LIST

5	[0060]	
	100	continuous hot-dip galvanizing apparatus
	10	heating zone
	10A	first heating zone (upstream)
10	10B	second heating zone (downstream, direct fired furnace)
	12	soaking zone
	14	first cooling zone (rapid cooling zone)
	16	second cooling zone (slow cooling zone)
	18	snout
15	20	annealing furnace
	22	hot-dip galvanizing bath
	24	alloying line
	31	first pipe
	32	second pipe
20	33	third pipe
	34	fourth pipe
	35	fifth pipe
	36	sixth pipe
	40	gas distribution device
25	50	humidifying device
	51	vapor permeable membrane
	52	module
	53A	inside of vapor permeable membrane (one space)
	53B	outside of vapor permeable membrane (other space)
30	54	circulating constant-temperature water bath
	55A, 55B	passage
	60	gas mixing device
	70A, 70B, 70C	mixed gas supply port
	71A, 71B, 71C	mixed gas supply port
35	72A, 72B, 72C, 72D	dry gas supply port
	73A	upper part hearth roll
	73B	lower part hearth roll
	74	mixed gas dew point meter
	75A, 75B	dew point measurement position
40	80	draining device
	82	first isolation valve
	84	second passage
	86	second isolation valve
	88	drainage tank
45	P	steel strip

Claims

- 50 1. A continuous hot-dip galvanizing apparatus comprising:
- an annealing furnace in which a heating zone, a soaking zone, and a cooling zone are arranged in this order;
 a hot-dip galvanizing line adjacent to the cooling zone;
 a first pipe through which a reducing or non-oxidizing dry gas passes;
 55 a gas distribution device that is connected to the first pipe and that distributes dry gas that has passed through the first pipe;
 a second pipe, a third pipe, and a fourth pipe that branch from the gas distribution device and through which dry gas that has been distributed by the gas distribution device passes;

a humidifying device that is connected to the second pipe and into which dry gas that has passed through the second pipe is introduced;

a fifth pipe that extends from the humidifying device and through which humidified gas that has been humidified by the humidifying device passes;

5 a gas mixing device that is connected to the third pipe and the fifth pipe and that prepares mixed gas by mixing dry gas that has passed through the third pipe and humidified gas that has passed through the fifth pipe;

a sixth pipe that extends from the gas mixing device and through which the mixed gas passes;

a mixed gas supply port disposed in the soaking zone for supplying mixed gas that has passed through the sixth pipe into the soaking zone; and

10 a dry gas supply port disposed in the soaking zone for supplying dry gas that has passed through the fourth pipe into the soaking zone, wherein

the humidifying device includes a module including a vapor permeable membrane, and is configured to humidify the dry gas that has passed through the second pipe by, while the dry gas passes through one space in the module that is separated by the vapor permeable membrane, circulating water through another space in the module using a circulating constant-temperature water bath, and

15 the continuous hot-dip galvanizing apparatus further comprises a draining device for draining water from the other space in the module when the mixed gas is not supplied to the soaking zone.

2. The continuous hot-dip galvanizing apparatus according to claim 1, further comprising
20 an alloying line adjacent to the hot-dip galvanizing line.

3. A method of producing a hot-dip galvanized steel sheet using the continuous hot-dip galvanizing apparatus according to claim 1, comprising:

25 annealing a steel strip by conveying the steel strip through the heating zone, the soaking zone, and the cooling zone inside of the annealing furnace, in this order; and

applying a hot-dip galvanized coating onto the steel strip exiting from the cooling zone using the hot-dip galvanizing line, wherein

30 in a first operational state in which the mixed gas and the dry gas are supplied to the soaking zone, water circulation is performed using the circulating constant-temperature water bath, and

in a second operational state in which only the dry gas is supplied to the soaking zone and the mixed gas is not supplied, distribution of the dry gas to the second pipe is stopped, water is drained from the other space in the module using the draining device, and water circulation with the circulating constant-temperature water tank is not performed.

35 4. The method of producing a hot-dip galvanized steel sheet according to claim 3, wherein when switching from the second operational state to the first operational state, water circulation using the circulating constant-temperature water bath is restarted and subsequently distribution of the dry gas to the second pipe is restarted.

40 5. The method of producing a hot-dip galvanized steel sheet according to claim 3 or 4, wherein a dew point in the soaking zone is controlled to $-20\text{ }^{\circ}\text{C}$ or higher and $0\text{ }^{\circ}\text{C}$ or lower in the first operational state.

45 6. The method of producing a hot-dip galvanized steel sheet according to any one of claims 3 to 5, further comprising heat-alloying the galvanized coating applied onto the steel strip using the alloying line according to claim 2.

50

55

FIG. 1

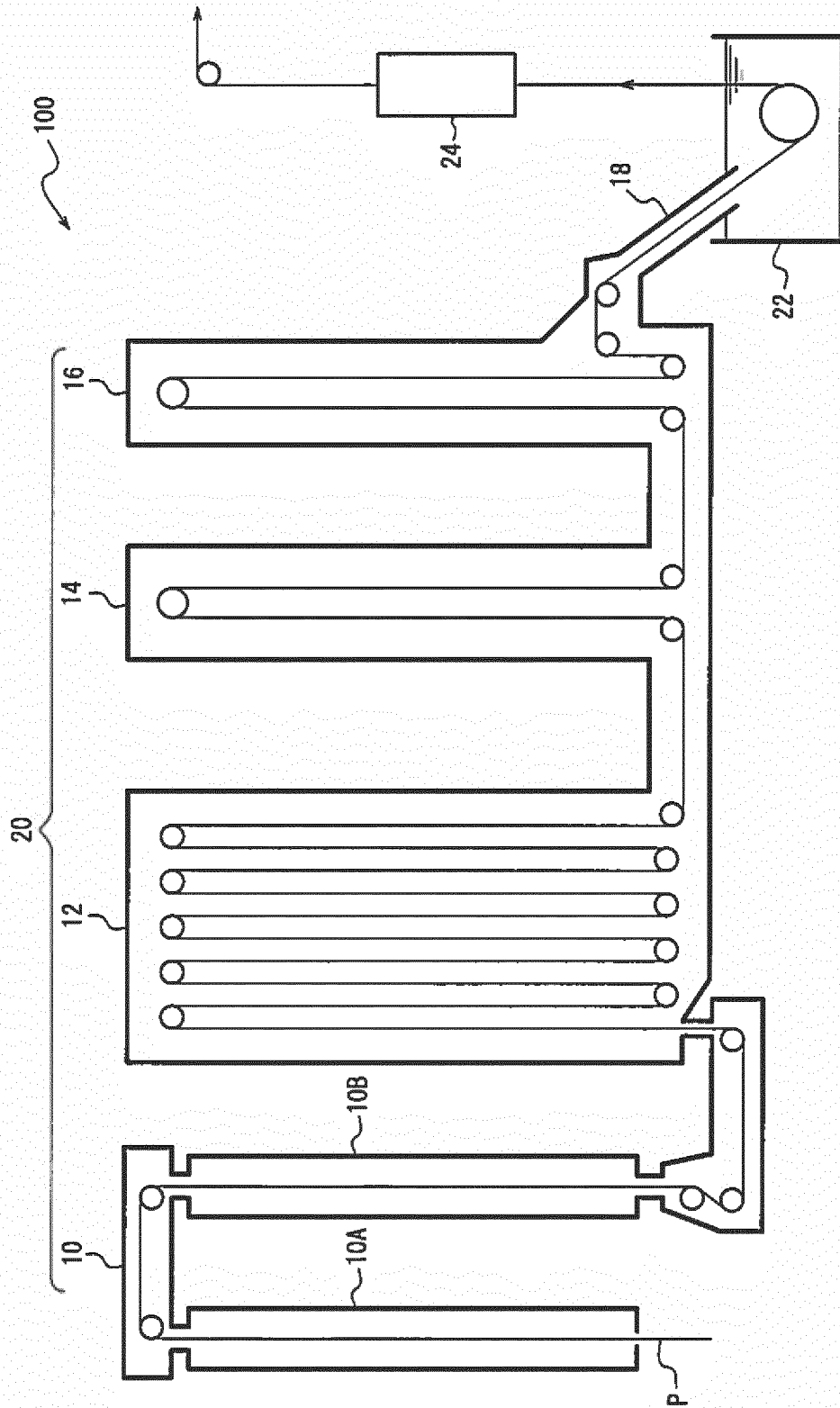
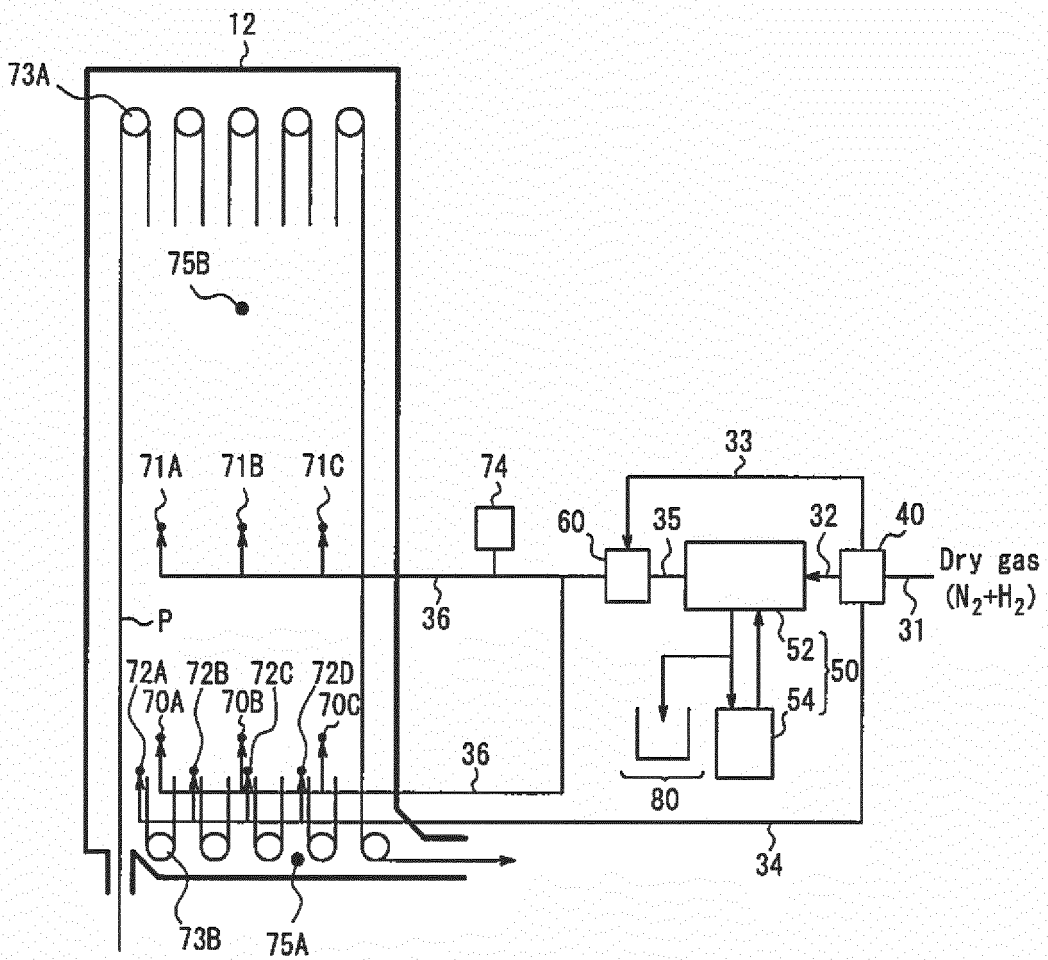

FIG. 2



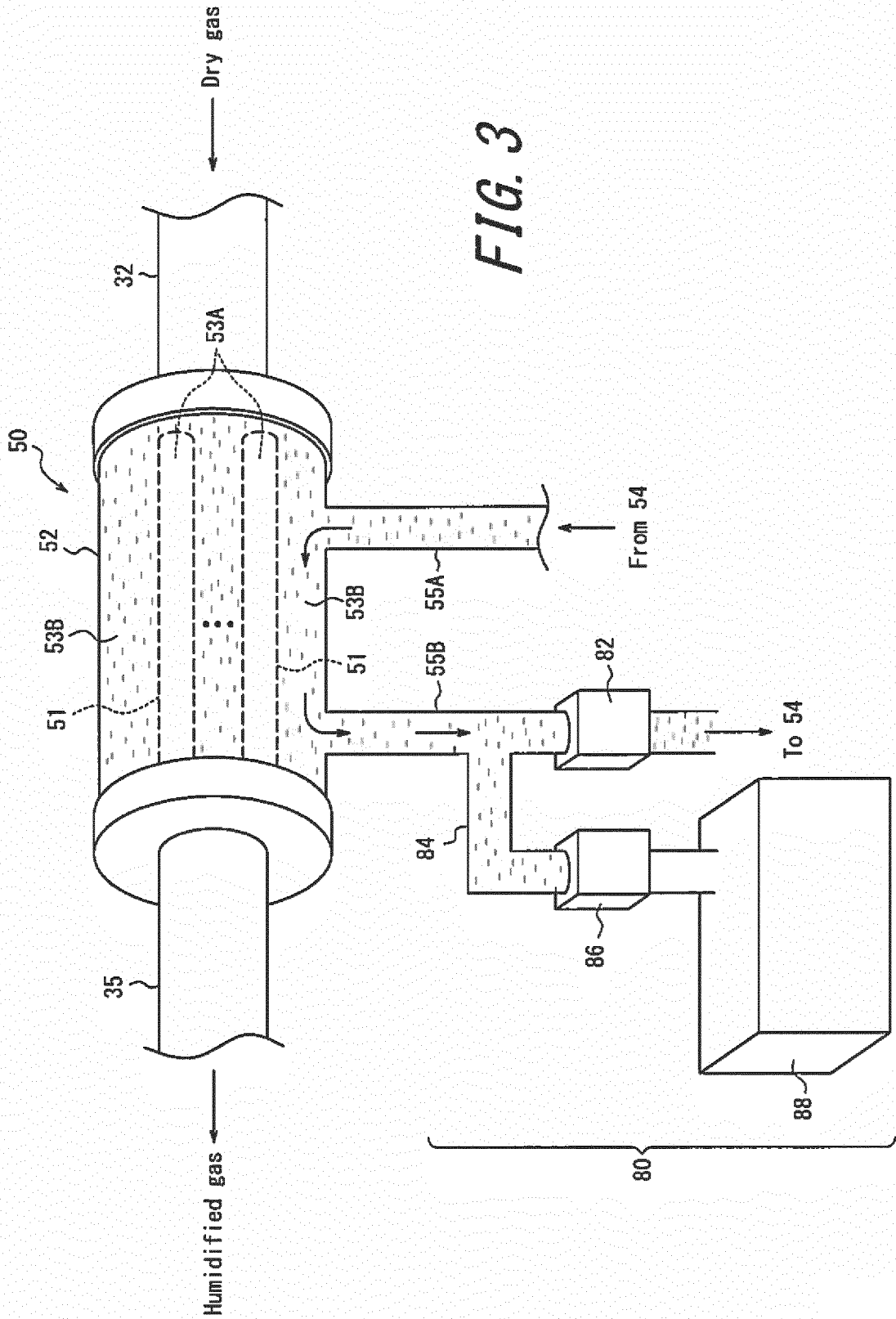

FIG. 3

INTERNATIONAL SEARCH REPORT

International application No.

PCT/JP2016/000899

5	A. CLASSIFICATION OF SUBJECT MATTER C23C2/02(2006.01)i, C21D1/76(2006.01)i, C21D9/46(2006.01)i, C21D9/56(2006.01)i, C23C2/28(2006.01)i, C23C2/40(2006.01)i, C22C18/04(2006.01)n, C22C38/00(2006.01)n, C22C38/14(2006.01)n According to International Patent Classification (IPC) or to both national classification and IPC	
10	B. FIELDS SEARCHED Minimum documentation searched (classification system followed by classification symbols) C23C2/02, C21D1/76, C21D9/46, C21D9/56, C23C2/28, C23C2/40, C22C18/04, C22C38/00, C22C38/14	
15	Documentation searched other than minimum documentation to the extent that such documents are included in the fields searched Jitsuyo Shinan Koho 1922-1996 Jitsuyo Shinan Toroku Koho 1996-2016 Kokai Jitsuyo Shinan Koho 1971-2016 Toroku Jitsuyo Shinan Koho 1994-2016	
20	Electronic data base consulted during the international search (name of data base and, where practicable, search terms used)	
25	C. DOCUMENTS CONSIDERED TO BE RELEVANT	
30	Category*	Citation of document, with indication, where appropriate, of the relevant passages
35		Relevant to claim No.
40	A	WO 2014/087452 A1 (JFE Steel Corp.), 12 June 2014 (12.06.2014), paragraphs [0012] to [0019]; fig. 1, 3 & US 2015/0315691 A1 paragraph [0028]; fig. 1, 3
45	A	WO 2013/153791 A1 (JFE Steel Corp.), 17 October 2013 (17.10.2013), paragraphs [0011] to [0020]; fig. 8 to 11 & US 2015/0114528 A1 paragraphs [0063] to [0075]; fig. 8 to 11
50	A	JP 2013-95952 A (JFE Steel Corp.), 20 May 2013 (20.05.2013), paragraphs [0012] to [0019]; fig. 1, 3 (Family: none)
55	<input checked="" type="checkbox"/> Further documents are listed in the continuation of Box C. <input type="checkbox"/> See patent family annex.	
	* Special categories of cited documents:	"T" later document published after the international filing date or priority date and not in conflict with the application but cited to understand the principle or theory underlying the invention "X" document of particular relevance; the claimed invention cannot be considered novel or cannot be considered to involve an inventive step when the document is taken alone "Y" document of particular relevance; the claimed invention cannot be considered to involve an inventive step when the document is combined with one or more other such documents, such combination being obvious to a person skilled in the art "&" document member of the same patent family
	"A" document defining the general state of the art which is not considered to be of particular relevance	
	"E" earlier application or patent but published on or after the international filing date	
	"L" document which may throw doubts on priority claim(s) or which is cited to establish the publication date of another citation or other special reason (as specified)	
	"O" document referring to an oral disclosure, use, exhibition or other means	
	"P" document published prior to the international filing date but later than the priority date claimed	
	Date of the actual completion of the international search 04 March 2016 (04.03.16)	Date of mailing of the international search report 15 March 2016 (15.03.16)
	Name and mailing address of the ISA/ Japan Patent Office 3-4-3, Kasumigaseki, Chiyoda-ku, Tokyo 100-8915, Japan	Authorized officer Telephone No.

Form PCT/ISA/210 (second sheet) (January 2015)

INTERNATIONAL SEARCH REPORT

International application No.
PCT/JP2016/000899

5

C (Continuation). DOCUMENTS CONSIDERED TO BE RELEVANT		
Category*	Citation of document, with indication, where appropriate, of the relevant passages	Relevant to claim No.
A	JP 2007-92140 A (Nippon Steel Corp.), 12 April 2007 (12.04.2007), paragraphs [0016] to [0034]; fig. 1 to 2 (Family: none)	1-6
A	JP 2002-3953 A (Sumitomo Metal Industries, Ltd.), 09 January 2002 (09.01.2002), paragraphs [0024] to [0042]; fig. 1 to 2 (Family: none)	1-6

10

15

20

25

30

35

40

45

50

55

REFERENCES CITED IN THE DESCRIPTION

This list of references cited by the applicant is for the reader's convenience only. It does not form part of the European patent document. Even though great care has been taken in compiling the references, errors or omissions cannot be excluded and the EPO disclaims all liability in this regard.

Patent documents cited in the description

- WO 2007043273 A1 [0005] [0006]