



(12) **EUROPEAN PATENT APPLICATION**

(43) Date of publication:
07.02.2018 Bulletin 2018/06

(51) Int Cl.:
E01B 9/48 (2006.01) E01B 9/50 (2006.01)

(21) Application number: **16183038.5**

(22) Date of filing: **05.08.2016**

(84) Designated Contracting States:
AL AT BE BG CH CY CZ DE DK EE ES FI FR GB GR HR HU IE IS IT LI LT LU LV MC MK MT NL NO PL PT RO RS SE SI SK SM TR
 Designated Extension States:
BA ME
 Designated Validation States:
MA MD

(71) Applicant: **Industrispar Svenska AB**
271 39 Ystad (SE)

(72) Inventor: **Andersson, Gert**
271 51 Ystad (SE)

(74) Representative: **Persson, Albin**
Hansson Thyresson Patentbyrå AB
Box 73
201 20 Malmö (SE)

(54) **FIXATION OF A RAIL TO A TIE PLATE BY MEANS OF CYLINDRICAL CLAMPING BOLTS**

(57) A rail fastening device (10) for fastening a rail (11) to a structure (12), comprising a baseplate (16) and a fastening element (17), wherein the baseplate has a support (22) with a through aperture (23) for receiving the fastening element (17), and wherein the fastening element (17) is arranged to extend through the aperture (23) and partly overlap a foot (15) of the rail (11) for fastening of the rail (11) to the baseplate (16). The aperture (23) is at least partially facing the rail (11) supported by the rail supporting portion (20) and the first end portion (28) of the fastening element (17) is arranged to be inserted through the aperture (23) and overlap the foot (15) of the rail (11). The first and second end portions (28, 29) of the fastening element are formed with a chamfer (31), and the fastening element (17) is arranged with a curvature, wherein the bottom portion of the intermediate portion (30) of the fastening element (17) is convex. Disclosed is also a method for fastening a rail (11) to a structure (12).

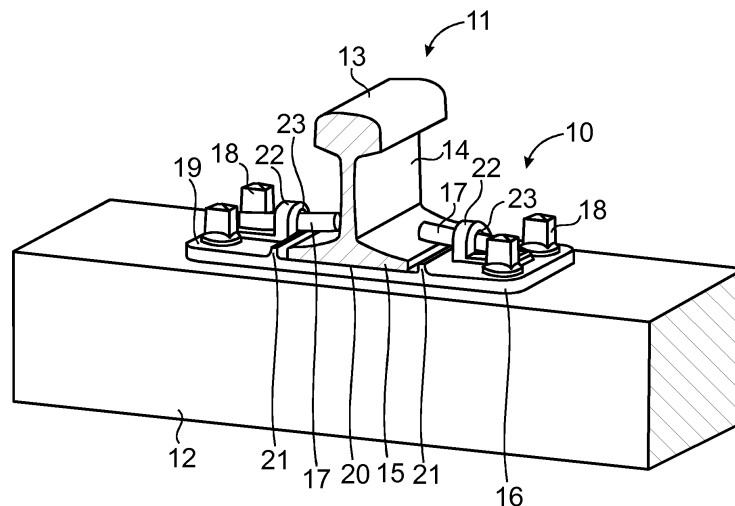

Fig. 1

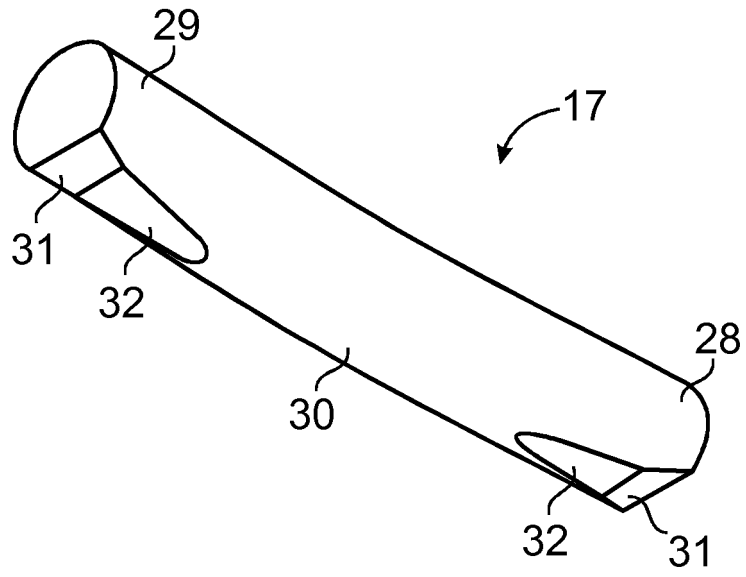

Fig. 14

Description

FIELD OF THE INVENTION

[0001] The invention relates to a device and a method for fastening a rail to a structure. The device and method of this type are used for fastening railroad rails, tram rails or similar to structures, such as sleepers (also called ties or cross-ties) or a road ground structure. Generally, railroad rails comprise a foot, a web and a head. A device of the intended type comprises a baseplate to be fixed to the structure and for supporting the rail, and a fastening element for clamping the foot of the rail to the baseplate.

PRIOR ART

[0002] There are several different types of devices for fastening railroad rail to sleepers and other types of structures in the prior art. One such type of fastening devices comprises a baseplate and a fastening element, wherein the baseplate is arranged for supporting the rail and wherein the fastening element is arranged for clamping the rail to the baseplate. The baseplate comprises a support with an aperture for receiving the fastening element, so that an end portion can be inserted into the aperture. The fastening element is elongated and can have rectangular cross section. Also the support and the aperture therein can have a rectangular shape corresponding to the fastening element. Known is also different types of fastening elements having substantially circular cross section which are used for fastening flat-bottomed rails to sleepers.

[0003] One problem with certain types of prior art devices for fastening rail to a structure is that they are difficult to use.

[0004] Another problem with certain types of such prior art devices is that they cannot withstand substantial loads and break relatively easy.

[0005] Another problem with prior art devices for fastening rail to a structure is that they are expensive to manufacture.

[0006] Yet another problem with certain types of prior art devices for fastening rail to a structure is that they can obstruct operations for maintenance along a railroad track.

[0007] Yet another problem with certain types of prior art devices for fastening rail to a structure is that they can cause damages on a pavement layer, such as an asphalt or tarmac layer, covering the underlying structure a part of the rail.

SUMMARY OF THE INVENTION

[0008] An object of the present invention is to avoid the problems of the prior art and further improve devices for fastening a railroad rail to a structure. The device according to the invention is inexpensive to manufacture and results in fast and easy installation of the rail. Further,

the device according to the invention results in a durable fastening which can withstand heavy loads without breaking. Also, the device according to the present invention results in a low profile fastening, which results in less obstruction during operations on a railroad track, such as machine operated snow clearance and other types of maintenance operations. Further, the low profile fastening device of the present invention results in reduced damages on a pavement layer, such as asphalt, tarmac, concrete or similar arranged to cover the structure and a lower part of the rail.

[0009] The present invention relates to a rail fastening device for fastening a rail to a structure, comprising a baseplate and a fastening element, wherein the baseplate is arranged to be fixed to the structure and comprises a top side having a rail supporting portion and a support with a through aperture for receiving the fastening element, wherein the fastening element is elongated, comprises a bottom portion, a top portion, a first end portion, a second end portion, an intermediate portion and a centre axis and is arranged to extend through the aperture and partly overlap a foot of the rail for fastening of the rail to the baseplate, characterised in that the aperture is arranged to face the rail when the rail is supported by the rail supporting portion of the baseplate, that the first end portion of the fastening element is arranged to be inserted through the aperture and overlap the foot of the rail, that the first and second end portions of the fastening element are formed with a chamfer, and that the fastening element is arranged with a curvature, wherein the bottom portion of the intermediate portion of the fastening element is convex. The chamfers and the curvature of the fastening element in combination with the aperture of the baseplate facing the rail or at least partially being arranged in a direction towards the web of the rail when the rail is supported by the rail supporting portion results in an efficient and easy fastening of the rail and an inexpensive fastening device. Further, compared to certain types of prior art fastening devices the fastening device of the present invention is more durable and can withstand higher stress without breaking.

[0010] The chamfer can comprise an inner bevel portion being less steep than the remaining outer portion of the chamfer. Hence, the fastening device is even more easy to insert through the aperture and brought to overlap the foot of the rail.

[0011] The fastening element or at least the intermediate portion thereof is arranged with a substantially circular cross section. Hence, the fastening element is inexpensive and easy to manufacture. For example, the fastening element can be manufactured from rods of hardened steel or similar inexpensive commodity materials.

[0012] Disclosed is also a method for fastening a rail to a structure by means of a baseplate and an elongated fastening element having a bottom portion, a top portion, a first end portion, a second end portion, an intermediate portion and a centre axis, comprising the steps of

a) fastening the baseplate to said structure,
 b) arranging the rail on a rail supporting portion on a top side of said baseplate,
 c) inserting, in a direction towards the rail, the first end portion of the fastening element into an aperture in a support of said baseplate,
 d) bringing said first end portion through the aperture and into engagement with a foot of the rail, and
 e) by means of a chamfer at the first and second end portions of the fastening element and by means of a curvature of the fastening element clamping the rail to the baseplate when the fastening element is driven further through the aperture towards the web of the rail.

[0013] Further characteristics and advantages of the present invention will become apparent from the description of the embodiments below, the appended drawings and the dependent claims.

SHORT DESCRIPTION OF THE DRAWINGS

[0014] The invention will now be described more in detail with the aid of embodiments and with reference to the appended drawings, in which

Fig. 1 is a schematic perspective view obliquely from above and partly in section of a part of a flat-bottom rail being fastened to a structure in the form of a sleeper by means of a device according to one embodiment,

Fig. 2 is a schematic front view, partly in section, of the device fixing the part of the rail to the sleeper according to Fig. 1,

Fig. 3 is a schematic view from above of the device, the part of the rail and the sleeper according to Fig. 1,

Fig. 4 is a schematic front view, partly in section, of a device fastening a grooved tram rail to a structure according to one embodiment,

Fig. 5 is a schematic view from above of the device, the part of the rail and the sleeper according to Fig. 4,

Fig. 6 is a schematic front view, partly in section, of a device fastening a grooved tram rail to a structure according to an alternative embodiment,

Fig. 7 is a schematic view from above of the device, the part of the rail and the sleeper according to Fig. 6,

Fig. 8 is a schematic front view, partly in section, of a device fastening a grooved tram rail to a structure according to a further alternative embodiment,

Fig. 9 is a schematic view from above of the device,

the part of the rail and the sleeper according to Fig. 8,

Fig. 10 is a schematic perspective view obliquely from above of a baseplate of the device according to one embodiment of the invention,

Fig. 11 is a schematic top view of the baseplate according to Fig. 10,

Fig. 12 is a schematic side view of the baseplate according to embodiment, illustrating a support and an aperture of the baseplate,

Fig. 13 is a schematic front view of the baseplate according to one embodiment,

Fig. 14 is a schematic perspective view obliquely from below of a fastening element of the device according to one embodiment,

Fig. 15 is a schematic end view of the fastening device according to one embodiment,

Fig. 16 is a schematic side view of the fastening device according to one embodiment, illustrating a curvature of the fastening device,

Fig. 17 is a schematic bottom view of the fastening device according to one embodiment, illustrating a chamfer at the end portions thereof, and

Figs. 18-21 is a series of figures schematically illustrating fastening of a rail to a structure by means of the device according to one embodiment.

THE INVENTION

[0015] With reference to Figs. 1-3 a device 10 for fastening a rail 11 to a structure 12 is illustrated schematically according to one embodiment. In the drawings a part of the rail 11 and a part of the structure 12 are illustrated schematically. In the embodiment of Figs. 1-3 the rail 11 is a conventional railroad rail comprising a head 13, a web 14 and a foot 15. For example, the rail 11 is a flat-bottom rail, such as a Vignoles rail or similar. For example, the structure 12 is a sleeper, such as a sleeper of wood, concrete, steel, plastic material or rubber materials. Alternatively, the structure 11 is a road ground structure, such as a road underlayer, including concrete, tarmac, asphalt and similar structures.

[0016] The device 10 comprises a baseplate 16 and a fastening element 17, wherein the baseplate 16 is arranged for supporting a part of the rail 11, and wherein the fastening element 17 is arranged for fastening the rail 11 to the baseplate 16. The baseplate 16 is fixed to the structure 12, e.g. by means of conventional fasteners, such as rail screws 18. For example, the baseplate 16 is fixed to a structure 12 in the form of a sleeper by means

of rail screws 18 being screwed into holes bored in the sleeper. For example, the baseplate 16 is arranged in metal, such as steel, hardened steel or similar. The baseplate 16 comprises a top side 19 having a rail supporting portion 20 for supporting the rail 11. The rail 11 is supported by the rail supporting portion 20 directly or indirectly, such as through an elastic plate or similar in a conventional manner. In the illustrated embodiment, the rail supporting portion 20 is defined by optional and conventional baseplate shoulders 21, wherein the rail 11 is arranged between the shoulders 21. Alternatively, the baseplate 16 comprises only one shoulder 21 or no shoulders. The baseplate 16 comprises at least one support 22 having a through aperture 23. For example, the support 22 is formed as a loop. In the illustrated embodiment the baseplate 16 comprises two supports 22 arranged on opposite sides of the rail supporting portion 20, wherein the rail supporting portion 20 is arranged between the supports 22. In the illustrated embodiment the shoulders 21 are arranged between the supports 22. The supports 22 project from the top side 19 of the baseplate 16, so that the supports 22 project above the rail supporting portion 20. For example, the supports 22 project perpendicular to a plane of the rail supporting portion 20. Hence, the supports 22 project in a vertical direction when the rails 11 run horizontally. For example, the supports 22 project in the same direction as the shoulders 21. The aperture 23 is arranged above the rail supporting portion 20. For example, the aperture 23 is arranged at least partially above the foot 15 of the rail 11. The aperture 23 extends in a direction towards the rail 11 when the rail 11 is supported by the rail supporting portion 20. For example, the apertures 23 of the supports 22 face each other. For example, the aperture 23 is straight, i.e. having a straight centre line, wherein the centre line extends substantially perpendicular to a longitudinal direction of the rail 11. Hence, the aperture 23 extends through the support 22 in a direction in parallel to the width of the foot 15 of the rail 11. The aperture 23 is arranged for receiving the fastening element 17, so that the fastening element 17 is insertable into and partly through the aperture 23 for fastening the rail 11 to the baseplate 16. The fastening element 17 is arranged to extend through the aperture 23 and partly overlap the foot 15 of the rail 11 for fastening of the rail 11 to the baseplate 16. For example, the fastening element 16 is arranged to clamp the rail 11 to the baseplate 16 by a wedging function. Hence, the fastening element 17 is brought into the aperture 23 and into contact with the foot 15 of the rail and into contact with the baseplate 16 to force the foot 15 of the rail 11 towards the rail supporting surface 20 and prevent displacement of the rail 11 in relation to the baseplate 16. As illustrated in the drawings fastening elements 17 are arranged through the apertures 23 of each of the supports 22, wherein fastening elements 17 are engaging top surfaces of the foot 15 on opposite sides of the web 14 of the rail 11. Hence, a first fastening element 17 is arranged through the aperture 23 of a first support 22, wherein a

separate second fastening element 17 is arranged through the aperture of a second support 22, the first and second supports being arranged on opposite sides of the rail supporting portion 20 on the top side 19 of the baseplate 16.

[0017] With reference to Figs. 4 and 5 the device 10 is arranged for fastening a rail 11 in the form of a grooved tram rail to a structure 12, such as a sleeper or similar supporting structure. The device 10 comprises the baseplate 16 and the one or more fastening elements 17 as described with reference to Figs. 1-3, wherein the baseplate 16 is fixed to the structure 12 by means of fasteners, such as conventional rail screws 18, and wherein the fastening elements 17 are arranged through the apertures 23 in the supports 22 to force the foot 15 of the rail 11 to the rail supporting portion 20 of the baseplate 16. For example, the structure 12, the device 10 and the foot 15 of the rail 11 are covered with a road construction material 24 forming a road surface or pavement, which is illustrated schematically in Fig. 4. For example, the road construction material 24 is arranged to the upper edges of the grooved head 13 of the rail 11.

[0018] With reference to Figs. 6 and 7 the device 10 is arranged for fastening a rail 11 in the form of a grooved tram rail to a structure 12, such as a supporting structure of concrete or similar solidifying materials. The device 10 comprises the baseplate 16 and the one or more fastening elements 17, wherein the top side 19 of the baseplate 16 is arranged as described with reference to Figs. 1-3, and wherein the baseplate 16 further comprises an anchor 25 to be received in the structure 12 before it solidifies, so that the anchor 25 is moulded into the structure 12 for fastening the baseplate 16 to the structure 12. In the embodiment of Figs. 6 and 7 the fastening elements 17 are arranged through the apertures 23 in the supports 22 to force the foot 15 of the rail 11 to the rail supporting portion 20 of the baseplate 16 as described above. Optionally, a road construction material 24 forming a road surface or pavement, as described with reference to Fig. 4 is covering the device 10, and is arranged substantially up to the upper edges of the rail 11.

[0019] With reference to Figs. 8 and 9 the device 10 is arranged for fastening a rail 11 in the form of a grooved tram rail to a structure 12, such as a supporting structure of concrete or similar solidifying materials as described with reference to Figs 6 and 7, wherein the baseplate 16 comprises or is provided with the anchor 25. However, the top side 19 of the baseplate 16 is arranged without the shoulders 21. For example, the rail supporting portion 20 of the baseplate 16 is defined by the supports 22.

[0020] With reference to Figs. 10-13 the baseplate 16 is illustrated according to one embodiment. The baseplate 16 according to Figs. 10-13 comprises the rail supporting portion 20 and the one or more supports 22. In the embodiment of Figs. 10-13 the baseplate 16 comprises two opposite supports 22 with the apertures 23 facing each other. Alternatively, the supports 22 are displaced in relation to each other, e.g. in a direction along

the rail 11, wherein the apertures 23, at least partially, are directed towards the rail supporting portion 20 so that the part of the fastening element 17 driven through the aperture 23 overlaps the foot 15 of the rail 11. Hence, the apertures 23 at least partially faces the rail 11 when the rail 11 is arranged on the rail supporting portion 20 of the baseplate 16. For example, the apertures 23 extend through the supports 22 in a direction substantially perpendicular to the longitudinal direction of the rail 11. Alternatively, the baseplate 16 comprises a single support 22.

[0021] As illustrated in Figs 10 and 11 the baseplate 16 is arranged with through holes 26 for receiving the fasteners, such as the rail screws 18. For example, the baseplate 16 is substantially rectangular, seen from above as illustrated in Fig. 11, and provided with rounded corners. In such an embodiment the baseplate 16 has long sides to be arranged substantially perpendicular to the longitudinal direction of the rail 11, wherein the apertures 23, e.g. extend through the supports 22 in a direction in parallel to said long sides. For example, the baseplate 16 is moulded in a single piece.

[0022] In the illustrated embodiment the baseplate 16 is comprises one or more elevated portions 27 for supporting a part of the fastening element 17. In the illustrated embodiment the baseplate 16 comprises two elevated portions 27 arranged on the top side 19 of the baseplate 16 on opposite sides of the rail supporting portion 20. For example, the elevated portions 27 are arranged adjacent to the supports 22. The support 22 is arranged between the elevated portion 27 and the rail supporting portion 20. The supports 22 are arranged between the elevated portions 27. For example, the elevated portions 27 are elevated 6-10 mm, such as around 8 mm.

[0023] With reference to Fig. 12 the support 22 is formed with the aperture 23 to provide a material thickness T around the aperture 23. The material thickness T is, for example, 8-20 mm, 10-14 mm or 12 mm. In the illustrated embodiment the support 22 is formed as an arch, wherein the aperture 23 at least has a rounded upper portion having a radius RA of, for example, 6-20 mm 8-16 mm or 10-12 mm. For example, the radius RA of the rounded upper portion of the aperture 23 is 10 mm. Except from the supports 22, optional shoulders 21 and optional elevated portions 27 the baseplate 16 is, for example, arranged with a thickness of 10-20 mm or about 15 mm.

[0024] With reference to Figs. 14-17 the fastening element 17 is illustrated according to one embodiment. The fastening element 17 comprises a bottom portion, a top portion, a first end portion 28, an opposite second end portion 29, an intermediate portion 30 and a centre axis A and is arranged to extend through the aperture 23 and overlap the foot 15 of the rail 11 for fastening of the rail 11 to the baseplate 16. The intermediate portion 30 is arranged between the first and second end portions 28, 29. The first end portion 28 is arranged to be inserted through the aperture 23 and overlap the foot 15 of the

rail 11. Hence, the first end portion 28 is arranged to be inserted into the aperture 23 from the outer side thereof and brought through the entire aperture 23 to a position in which the first end portion 28 projects from the inner side of the aperture 23 and engages the foot 15 of the rail 11, while the second end portion 29 engages the baseplate 16. For example, the second end portion 29 then projects from the outer side of the aperture 23. The fastening element 17 is substantially cylindrical, e.g. at least partially having a substantially circular cross section. For example, at least the intermediate portion 30 has a circular cross section. In the illustrated embodiment the first and second end portions 28, 29 are similar.

[0025] The first and second end portions 28, 29 of the fastening element 17 are formed with a chamfer 31. The chamfers 31 are arranged in the bottom portion of the fastening element 17, so that the chamfers 31 are arranged downwards when the fastening element 17 is arranged through the aperture 23. The chamfer 31 of the first end portion 28 is arranged for engaging or facing the foot 15 of the rail 11, wherein the chamfer 31 of the second end portion 29 is arranged for engaging or facing the baseplate 16, such as the elevated portion 27 thereof. For example, the chamfer 31 is arranged with a length C of 2-10 mm, 4-8 mm or about 6 mm, which is illustrated in Fig. 16.

[0026] In the illustrated embodiment the chamfer 31 of the fastening element 17 comprises an inner bevel portion 32 being less steep than the remaining part of the chamfer 31. Hence, the bevel portion 32 is arranged between the remaining outer part of the chamfer 31 and the intermediate portion 30 of the fastening element 17. Alternatively, the bevel portion 32 extends into the intermediate portion 30. For example, both chamfers 31 comprise the bevel portions 32, wherein the bevel portions 32 are arranged in the bottom portion of the fastening element 17. The bevel portion 32 of the first end portion 28 is arranged for engaging the foot 15 of the rail 11, wherein the bevel portion 32 of the second end portion 29 is arranged for engaging the baseplate 16, such as the elevated portion 27 thereof. The bevel portion 32 is, e.g. arranged with a length B of 10-30 mm, 15-25 mm or about 20 mm, such as 19 mm. For example, the outer part of the chamfer 31 is arranged with an angle in relation to the bevel portion 32 and the length C to provide a difference G of about 1 mm between the outer edge of the chamfer 31 and the outer edge of the bevel portion 32. Alternatively, the chamfer 31 is arranged without the bevel portion 32 and is, e.g. arranged with constant or varying inclination.

[0027] The fastening element 17 is arranged with a curvature. The curvature is arranged so that the end portions 28, 29 are bent slightly upwards in relation to the intermediate portion 30 when the fastening element 17 is arranged horizontally with the chamfer 31 facing downwards. Hence, the curvature is arranged so that the first end portion 28 is arranged above the intermediate portion 30 when the rail 11 is secured to the baseplate 16 by

means of the fastening element 17. For example, at least the intermediate portion 30 is arranged with the curvature, wherein the centre axis A of the intermediate portion 30 is formed with a curvature having a radius RC. Alternatively, the entire fastening element 17 is arranged with said curvature. For example, the intermediate portion 30 extends between central parts of the bevel portions 32 as illustrated by means of the length l in in Fig. 16. Alternatively, the intermediate portion 30 extends to the outer edge of the bevel portions 32 or to the inner edge of the bevel portions 32. For example, the radius RC of the curvature is 400-600 mm or around 500 mm. For example, the length l of the intermediate portion 30 is 50-100 mm, 60-90 mm, 70-80 mm or around 75 mm. According to the illustrated embodiment the centre line A is curved at the end portions 28, 29 in relation to the intermediate portion 30 and in the opposite direction as the curvature of the intermediate portion 30, which is indicated by means of the radius RE in Fig. 16. For example, the radius RE is 100-300 mm, 150-250 mm or about 200 mm. For example, the length and curvature of the fastening element 17 is arranged so that a deviation from a straight line between the end and the mid parts of the fastening element is 1-3 mm or about 2 mm as indicate by means of the arrows K in Fig. 16. For example, the fastening element 17 is arranged with a total length F of 80-120 mm, 100-110 mm or about 105 mm. For example, the fastening element 17 is arranged with a diameter D of 16-20 mm or about 18 mm, except at the chamfers 31, optionally with the bevel portions 32.

[0028] With reference to Figs. 18-21 fixing of a rail 11 to the structure 12 in the form of a sleeper is illustrated schematically according to one embodiment. The baseplate 16 is fixed to the structure 12 by means of fastening means. In the embodiment of Fig. 18 holes 33 are arranged in the structure 12 for receiving fastening means in the form of rail screws 18. Then, the baseplate 16 is arranged on a top surface of the structure 12 and is fixed to the structure 12 by means of the rail screws 18, which are screwed through the holes 26 in the baseplate 16 and into the holes 33 in the structure 12, which is illustrated by means of the arrows M in Fig. 18. The rail 11 is arranged on the rail supporting portion 20 of the baseplate 16. For example, the rail 11 is arranged between the shoulders 21 and between the supports 22 with the apertures 23, which is illustrated schematically by means of the arrow N in Fig. 19, wherein the rail 11 is supported, either directly or indirectly, by the top side 19 of the baseplate 16. Optionally, an elastomeric plate or similar is arranged between the rail supporting portion 20 and the rail 11. Then, the fastening elements 17 are introduced into the aperture 23, which is illustrated by means of the arrows O and P in Fig. 20. In Fig. 20 the rail screws 18 are not illustrated. Hence, the first end portion 28 is brought into the aperture 23 from the outer side thereof and is brought through the aperture 23 and out from the inner side thereof, i.e. the side facing the rail 11. For example, the fastening element 17 is forced towards the

rail 11 by means of a tool for applying force on the second end portion 29 in a direction substantially along the centre axis A of the fastening element 17. The fastening element 17 is forced in a direction substantially perpendicular to the longitudinal direction of the rail 11. The first end portion 28 is brought to engage the foot 15 of the rail 11, wherein a top portion of the intermediate portion 30 is brought against the inner top surface of the support 22 inside the aperture 23 and the second end portion 29 is brought to engage the baseplate 16, such as the elevated portion 27, so that the fastening element 17 is wedged towards the foot 15 of the rail 11 through the aperture 23 in the support 22 and the second end portion abutting the baseplate 16. In the illustrated embodiment the fastening elements 17 are brought towards the web 14 of the rail 11 in opposite directions, such as towards each other to engage the foot 15 of the rail 11 on opposite sides of the web 14. The fastening element 17 is efficiently wedged to the rail 11 and the baseplate 16 by means of the design of the fastening element 17 and the baseplate 16, including the curvature and the chamfers 31, 32 of the fastening element 17. Hence, the chamfer 31 of the first end portion 28 is brought into engagement with the foot 15 of the rail 11, wherein the chamfer 31 of the second end portion 29 is brought into engagement with the top side 19 of the baseplate 16 or the elevated portion 27 while the concavely curved top portion of the intermediate portion 30 is brought against the support 22 inside the aperture 23. For example, the bevel portions 32 of the chamfers 31 are brought into contact with the foot 15 of the rail 11 and the top side of the baseplate 16 or the elevated portion 27 thereof, respectively. Then, optionally the construction material 24 is arranged on top of the baseplate 16, which is illustrated in Fig. 21.

Claims

1. A rail fastening device (10) for fastening a rail (11) to a structure (12), comprising a baseplate (16) and a fastening element (17), wherein the baseplate (16) is arranged to be fixed to the structure (12) and comprises a top side (19) having a rail supporting portion (20) and a support (22) with a through aperture (23) for receiving the fastening element (17), wherein the fastening element (17) is elongated, comprises a bottom portion, a top portion, a first end portion (28), a second end portion (29), an intermediate portion (30) and a centre axis (A) and is arranged to extend through the aperture (23) and partly overlap a foot (15) of the rail (11) for fastening of the rail (11) to the baseplate (16),
characterised in
that the aperture (23) at least partially is facing the rail (11) when the rail (11) is supported by the rail supporting portion (20),
that the first end portion (28) of the fastening

- element (17) is arranged to be inserted through the aperture (23) and overlap the foot (15) of the rail (11),
that the first and second end portions (28, 29) of the fastening element are formed with a chamfer (31), and
that the fastening element (17) is arranged with a curvature, wherein the bottom portion of the intermediate portion (30) of the fastening element (17) is convex.
2. A rail fastening device according to claim 1, wherein the chamfer (31) is arranged in the bottom portion of the fastening element (17) when the fastening element (17) is inserted through the aperture (23).
3. A rail fastening device according to claim 1 or 2, wherein the chamfer (31) comprises an inner bevel portion (32) being less steep than the remaining part of the chamfer (31).
4. A rail fastening device according to any of the preceding claims, wherein the top portion of the fastening element (17) is concave.
5. A rail fastening device according to any of the preceding claims, wherein the intermediate portion (30) of the fastening element (17) is arranged with a substantially circular cross section.
6. A rail fastening device according to any of the preceding claims, wherein the fastening element (17), apart from the chamfer (31), is formed with a substantially circular cross section.
7. A rail fastening device according to any of the preceding claims, wherein the top side (19) of the baseplate (16) comprises supports (22) with apertures (23) on opposite sides of the rail supporting portion (20).
8. A rail fastening device according to claim 7, wherein the apertures (23) of the supports (22) are facing each other.
9. A method for fastening a rail (11) to a structure (12) by means of a fastening device (10) comprising a baseplate (16) and an elongated fastening element (17) having a bottom portion, a top portion, a first end portion (28), a second end portion (29), an intermediate portion (30) and a centre axis (A), comprising the steps of
- a) fastening the baseplate (16) to said structure (12),
b) arranging the rail (11) on a rail supporting portion (20) on a top side (19) of said baseplate (16),
c) inserting, in a direction towards the rail (11), the first end portion (28) of the fastening element (17) into an aperture (23) in a support (22) of said baseplate (16),
d) bringing said first end portion (28) through the aperture (23) and into engagement with a foot (15) of the rail (11), and
e) by means of a chamfer (31) at the first and second end portions (28, 29) of the fastening element (17) and by means of a curvature of the fastening element (17) clamping the rail (11) to the baseplate (16) when the fastening element (17) is driven further through the aperture towards a web (14) of the rail (11).
10. A method according to claim 9, comprising the steps of
- bringing the chamfer (31) of the first end portion (28) into engagement with the foot (15) of the rail (11), and
- bringing the chamfer (31) of the second end portion (29) into engagement with the baseplate (16).
11. A method according to claim 9 or 10, comprising the step of driving the fastening element (17) towards the web (14) of the rail (11) in a direction perpendicular to a longitudinal direction of the rail (11).
12. A method according to any of claims 9-11, comprising the step of arranging the fastening element (17) so that a bottom portion of the intermediate portion (30) is convex.
13. A method according to any of claims 9-12, comprising the step of arranging the fastening element (17) so that a top portion of the intermediate portion (30) is concave.
14. A method according to any of claims 9-13, comprising the step of fastening grooved tram rail to a road ground structure and/or a flat-bottom rail to a sleeper.

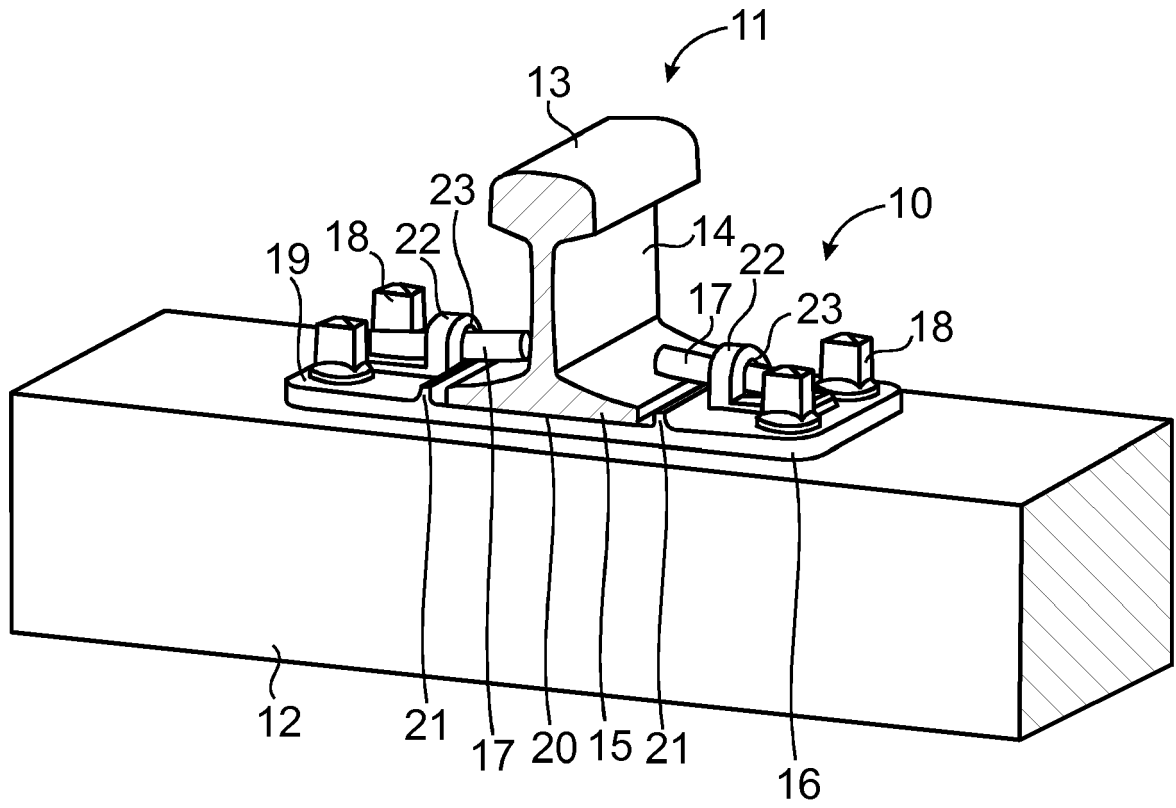

Fig. 1

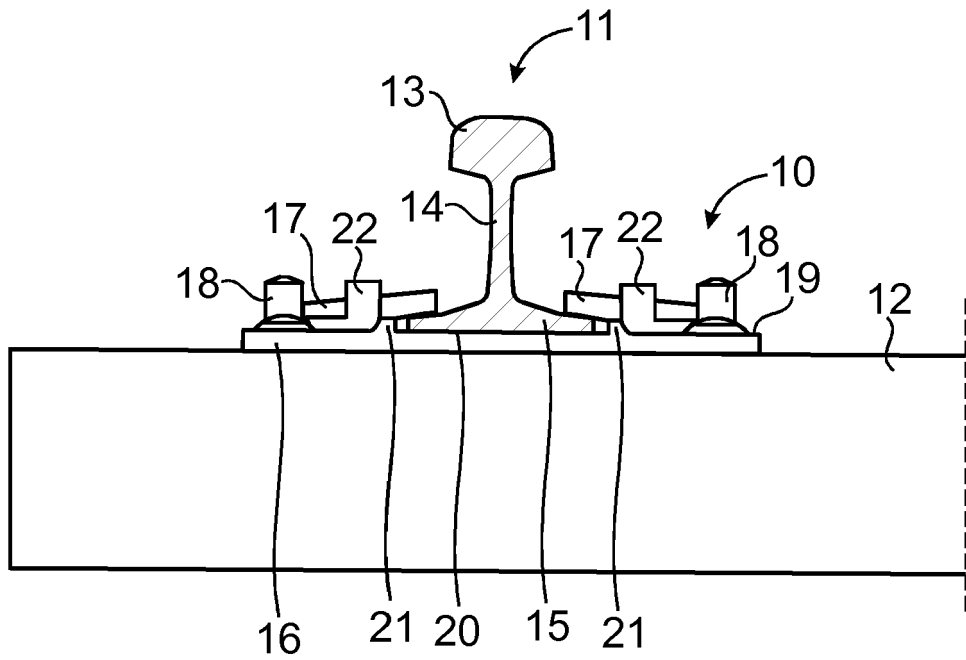

Fig. 2

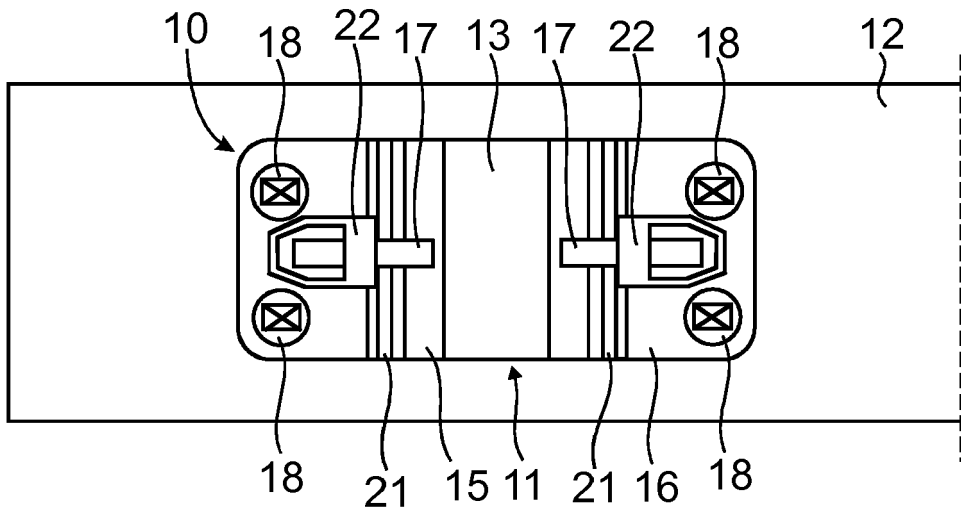

Fig. 3

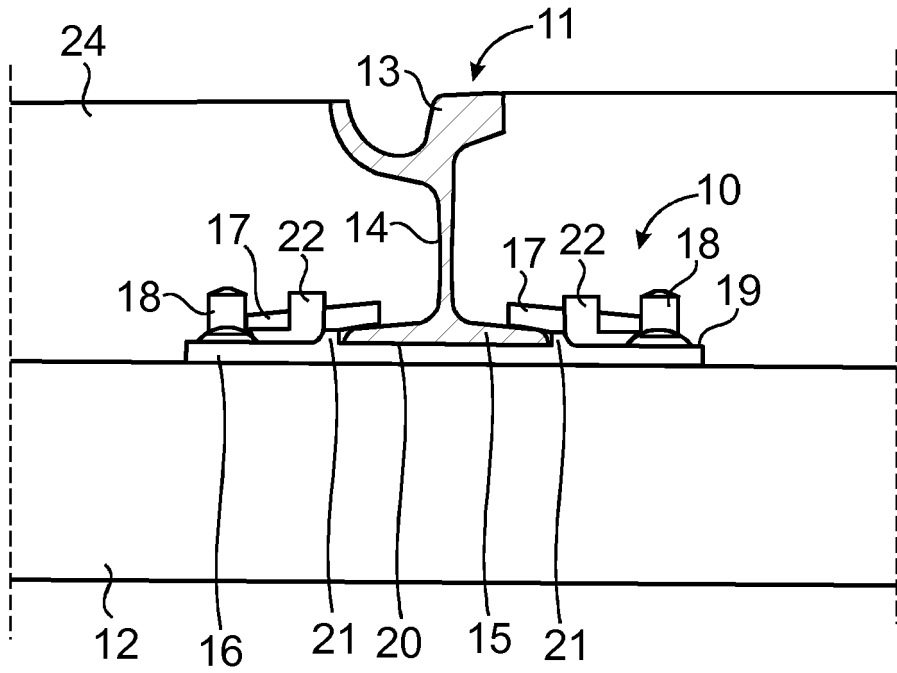

Fig. 4

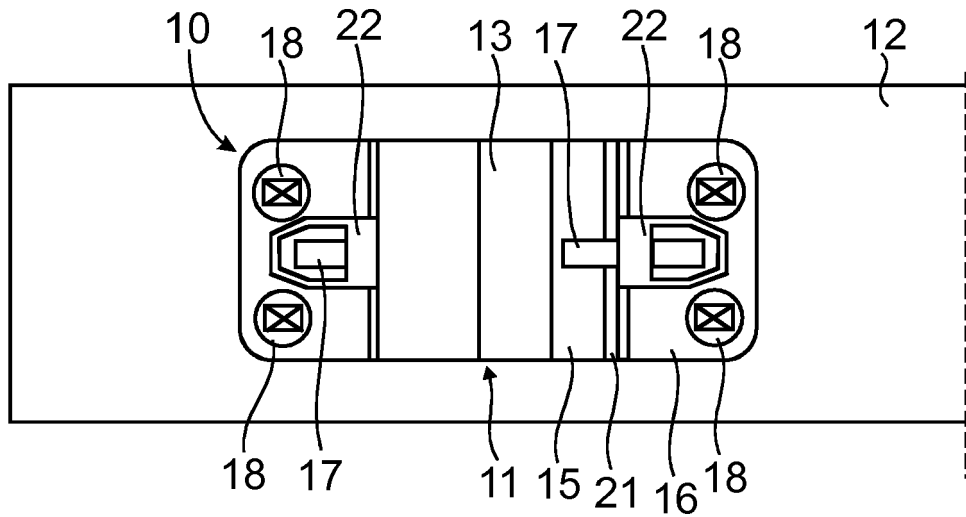

Fig. 5

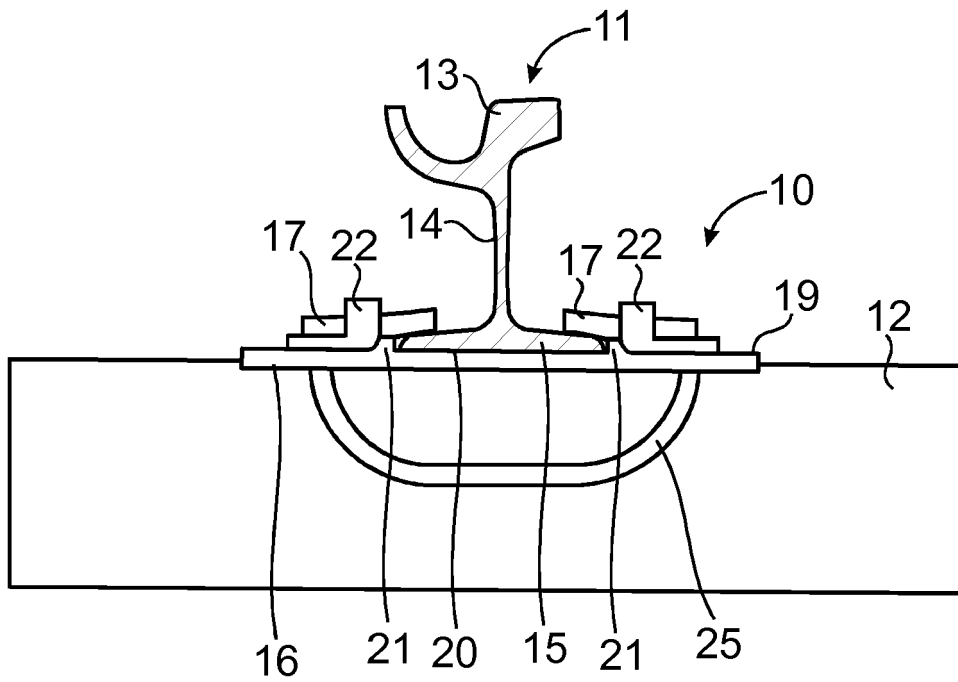

Fig. 6

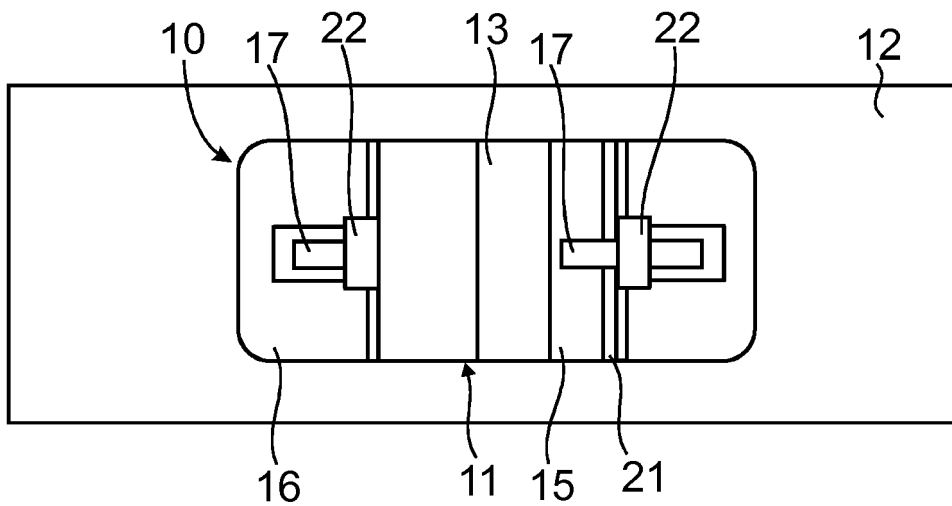

Fig. 7

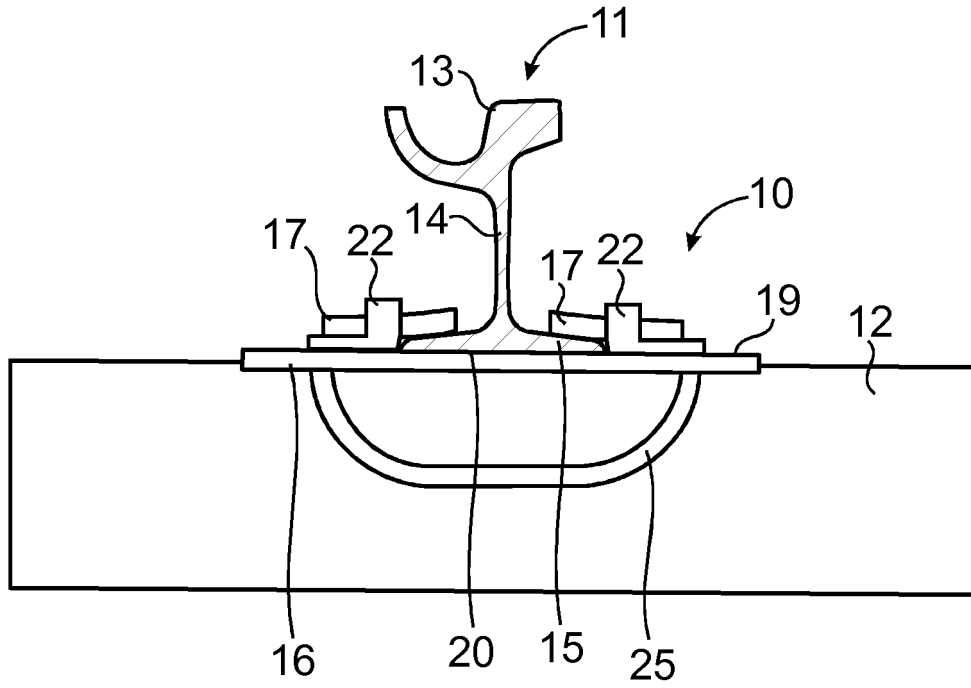

Fig. 8

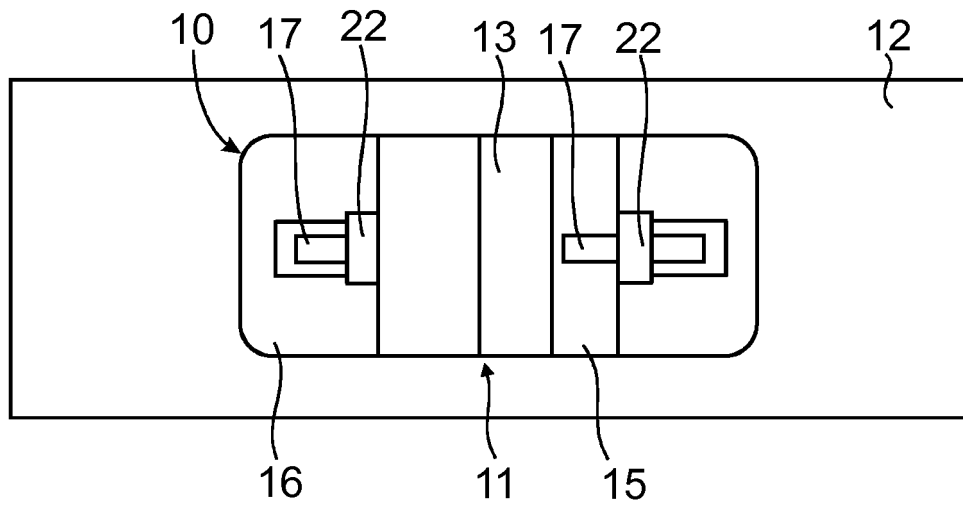

Fig. 9

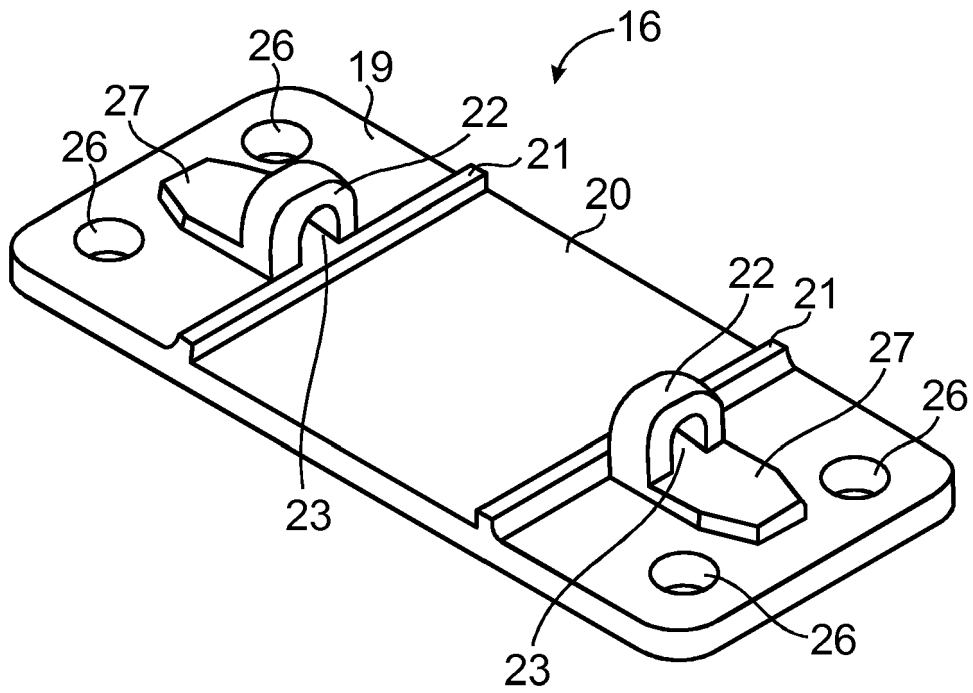

Fig. 10

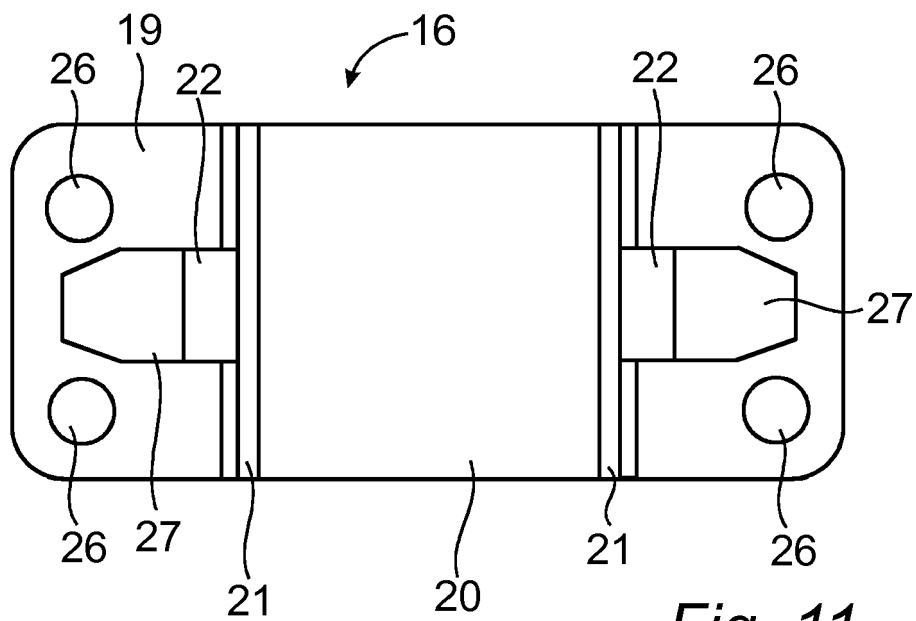

Fig. 11

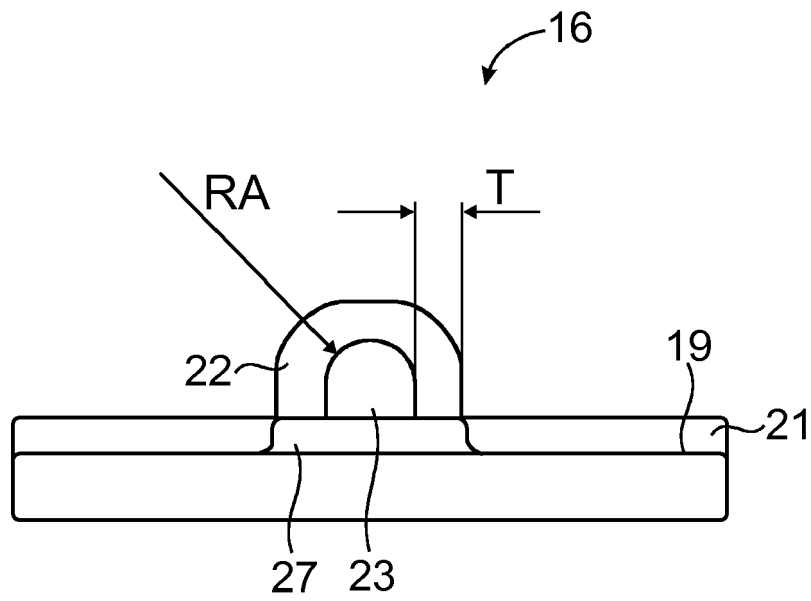

Fig. 12

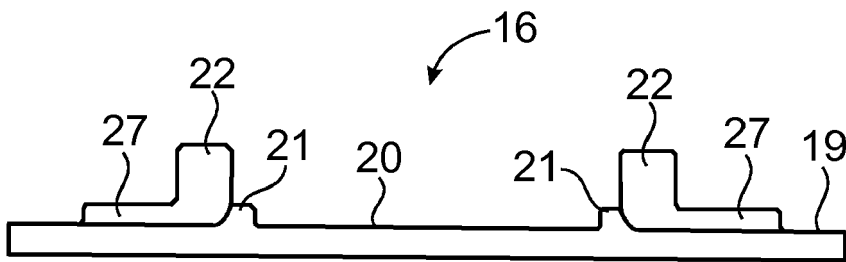

Fig. 13

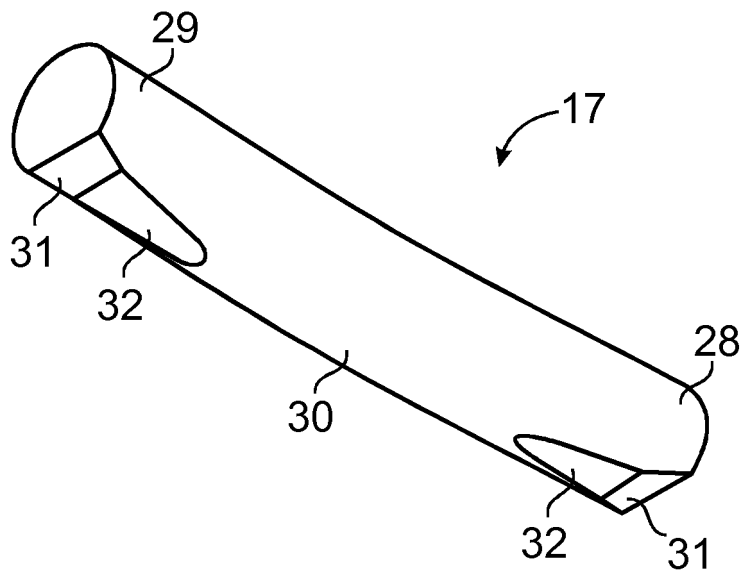

Fig. 14

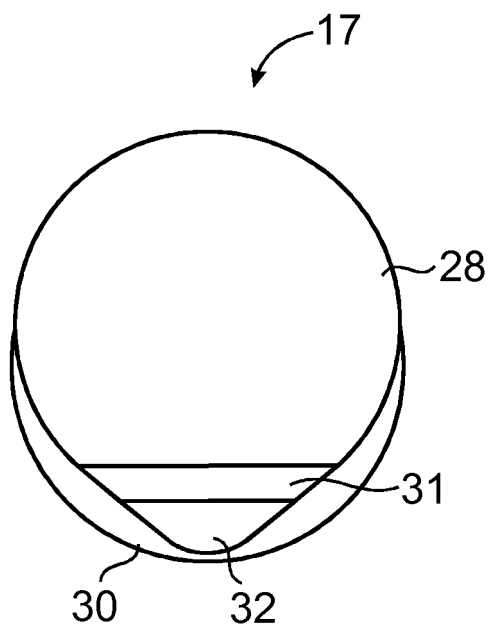

Fig. 15

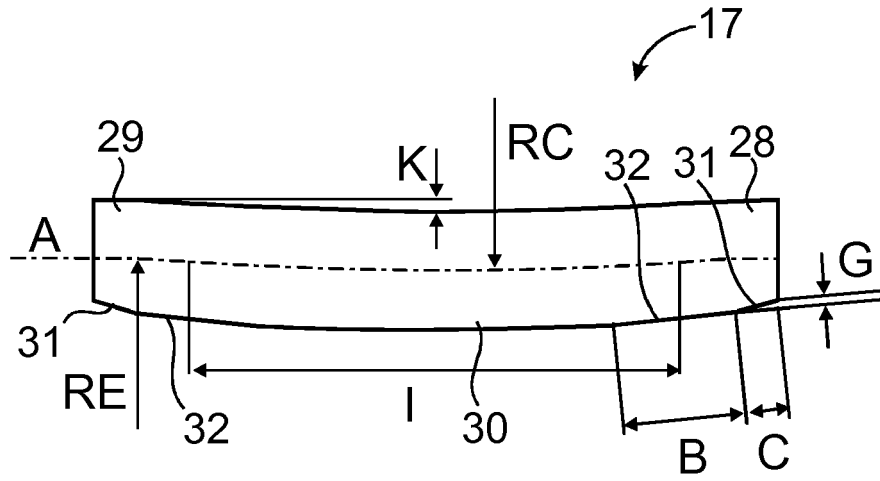

Fig. 16

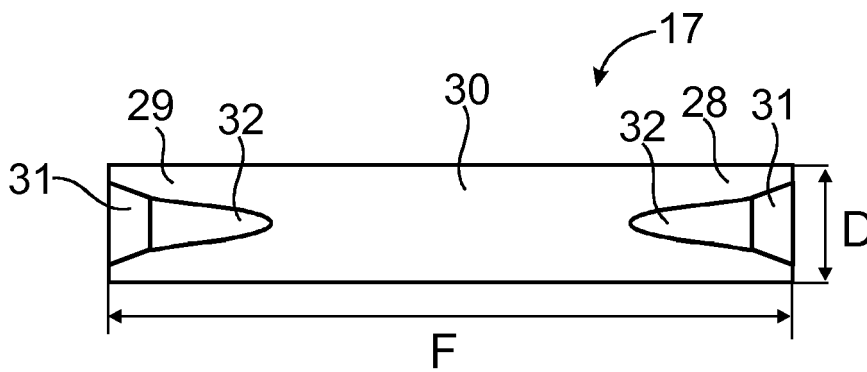

Fig. 17

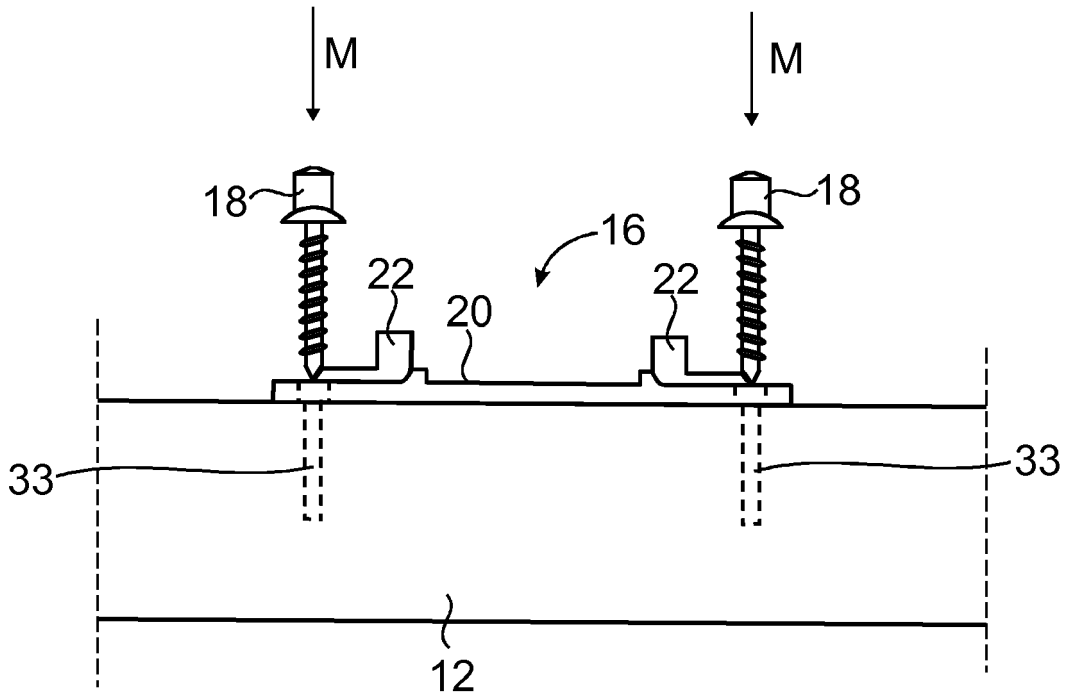

Fig. 18

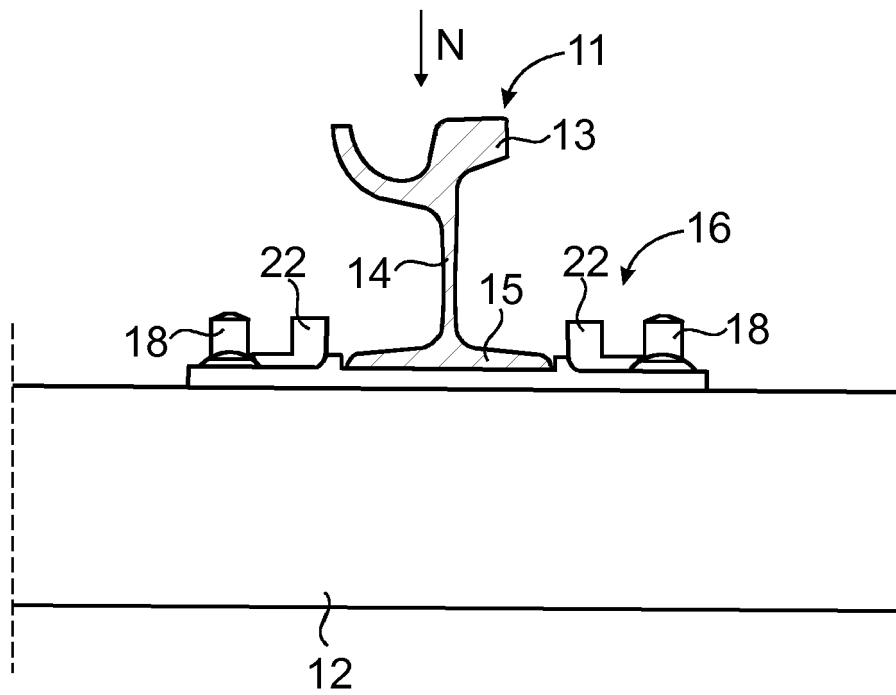

Fig. 19

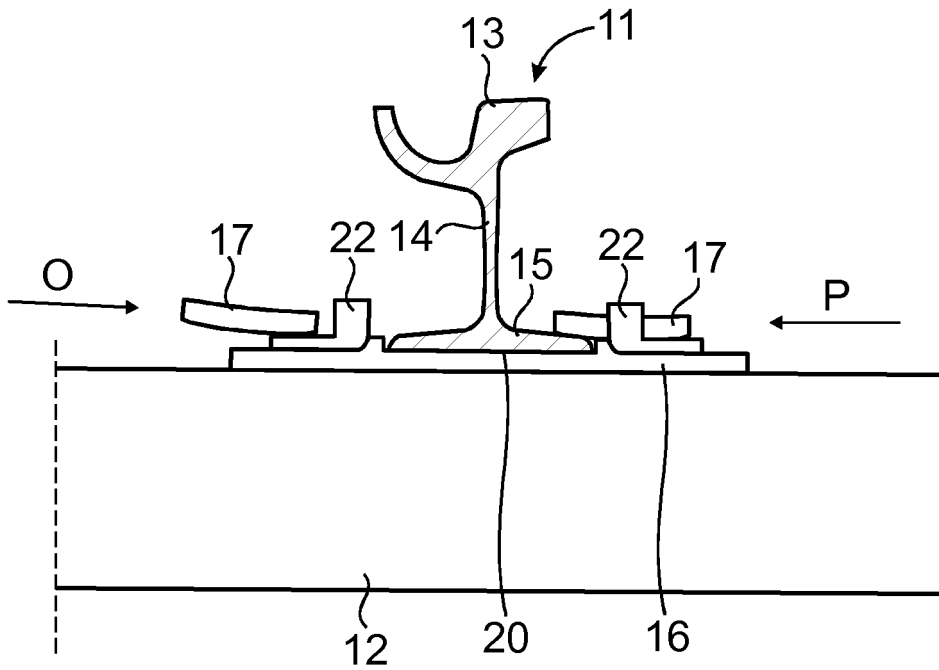

Fig. 20

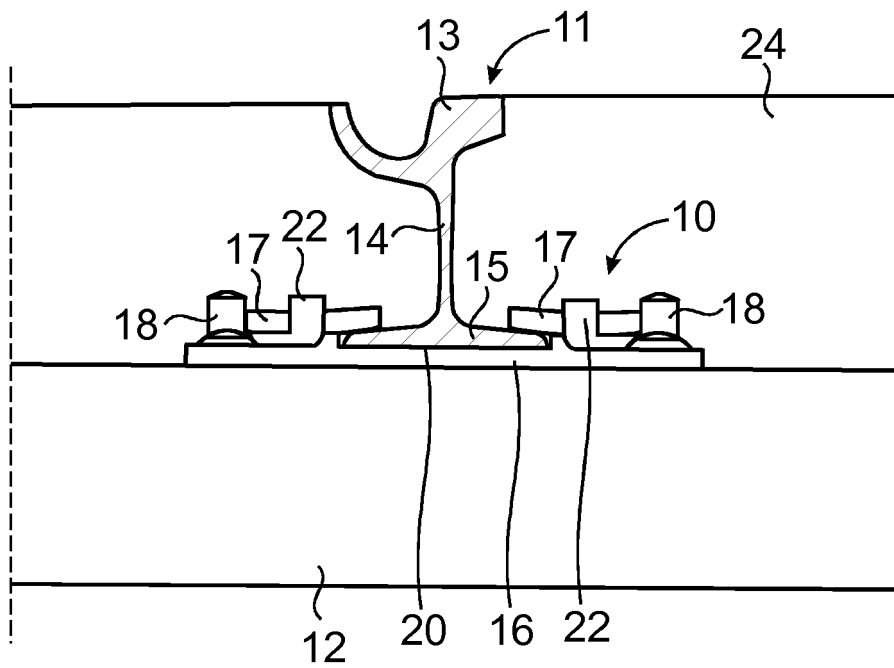

Fig. 21



EUROPEAN SEARCH REPORT

Application Number
EP 16 18 3038

5

10

15

20

25

30

35

40

45

50

55

DOCUMENTS CONSIDERED TO BE RELEVANT			
Category	Citation of document with indication, where appropriate, of relevant passages	Relevant to claim	CLASSIFICATION OF THE APPLICATION (IPC)
X	US 1 379 531 A (COOPER FRANCIS W ET AL) 24 May 1921 (1921-05-24)	1-4,9-14	INV. E01B9/48 E01B9/50
Y	* page 1 - page 2; figures 1-4 *	5-8	
Y	US 2 645 427 A (CLOVIS NAUD) 14 July 1953 (1953-07-14) * figures 1-4 *	5-8	
Y	WO 2006/106089 A2 (KOELNER VERKEHRS BETR E AG [DE]; LOEFFELSEND HERMANN-JOSEF [DE]; WENGL) 12 October 2006 (2006-10-12) * figure 1 *	7,8	
The present search report has been drawn up for all claims			TECHNICAL FIELDS SEARCHED (IPC)
			E01B
Place of search		Date of completion of the search	Examiner
Munich		11 January 2017	Schwertfeger, C
CATEGORY OF CITED DOCUMENTS			
X : particularly relevant if taken alone		T : theory or principle underlying the invention	
Y : particularly relevant if combined with another document of the same category		E : earlier patent document, but published on, or after the filing date	
A : technological background		D : document cited in the application	
O : non-written disclosure		L : document cited for other reasons	
P : intermediate document		& : member of the same patent family, corresponding document	

EPO FORM 1503 03/02 (P04C01)

**ANNEX TO THE EUROPEAN SEARCH REPORT
ON EUROPEAN PATENT APPLICATION NO.**

EP 16 18 3038

5 This annex lists the patent family members relating to the patent documents cited in the above-mentioned European search report.
The members are as contained in the European Patent Office EDP file on
The European Patent Office is in no way liable for these particulars which are merely given for the purpose of information.

11-01-2017

Patent document cited in search report	Publication date	Patent family member(s)	Publication date
US 1379531 A	24-05-1921	NONE	

US 2645427 A	14-07-1953	NONE	

WO 2006106089 A2	12-10-2006	AT 468436 T	15-06-2010
		CN 101160434 A	09-04-2008
		EP 1866481 A2	19-12-2007
		US 2008191049 A1	14-08-2008
		WO 2006106089 A2	12-10-2006

EPO FORM P0459

For more details about this annex : see Official Journal of the European Patent Office, No. 12/82